



US008752630B2

(12) **United States Patent**
Swietlik et al.

(10) **Patent No.:** **US 8,752,630 B2**
(45) **Date of Patent:** **Jun. 17, 2014**

(54) **FLOW STOP VALVE**

(56) **References Cited**

(71) Applicants: **George Swietlik**, Lowestoft (GB);
Robert Large, Lowestoft (GB)

U.S. PATENT DOCUMENTS

(72) Inventors: **George Swietlik**, Lowestoft (GB);
Robert Large, Lowestoft (GB)

1,447,621 A	3/1923	Ban Medowell et al.
1,735,718 A	11/1929	Attendu
2,214,550 A	9/1940	Edwards
2,644,528 A	7/1953	Ragan
2,647,015 A	7/1953	Berlyn
2,647,016 A	7/1953	Berlyn
2,647,583 A	8/1953	Bernard
2,715,943 A	8/1955	True
2,743,078 A	4/1956	Walter

(73) Assignee: **Pilot Drilling Control Limited**,
Lowestoft (GB)

(Continued)

(*) Notice: Subject to any disclaimer, the term of this
patent is extended or adjusted under 35
U.S.C. 154(b) by 0 days.

FOREIGN PATENT DOCUMENTS

(21) Appl. No.: **13/655,322**

CA	2285767 A1	4/2000
EP	0322170 A2	6/1989

(Continued)

(22) Filed: **Oct. 18, 2012**

OTHER PUBLICATIONS

(65) **Prior Publication Data**

PCT/GB2009/000414; International Search Report Published Feb.
11, 2010.

US 2013/0043045 A1 Feb. 21, 2013

(Continued)

Related U.S. Application Data

Primary Examiner — David Andrews

Assistant Examiner — Robert E Fuller

(62) Division of application No. 12/867,595, filed as
application No. PCT/GB2009/000414 on Feb. 16,
2009, now Pat. No. 8,590,629.

(74) *Attorney, Agent, or Firm* — MH2 Technology Law
Group

(30) **Foreign Application Priority Data**

(57) **ABSTRACT**

Feb. 15, 2008 (GB) 0802856.5

A flow stop valve (20) positionable in a downhole tubular (6),
and a method, are provided. The flow stop valve (20) is in a
closed position when a pressure difference between fluid
outside the downhole tubular (6) and inside the downhole
tubular (6) at the flow stop valve (20) is below a threshold
value, thereby preventing flow through the downhole tubular.
The flow stop valve (20) is in an open position when the
pressure difference between fluid outside the downhole tubular
(6) and inside the downhole tubular (6) at the flow stop
valve (20) is above a threshold value, thereby permitting flow
through the downhole tubular (6).

(51) **Int. Cl.**
E21B 34/08 (2006.01)

(52) **U.S. Cl.**
USPC **166/321**; 166/325; 175/243; 175/318

(58) **Field of Classification Search**
USPC 166/386, 373, 321, 325, 332.1;
175/232, 243, 316, 318, 317

See application file for complete search history.

18 Claims, 9 Drawing Sheets

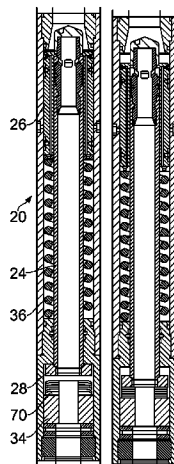

(56)

References Cited

U.S. PATENT DOCUMENTS

2,757,741 A 8/1956 O'Relly
 2,796,938 A 6/1957 John
 2,909,227 A 10/1959 Bostock
 3,077,898 A 2/1963 Raymond
 3,090,443 A 5/1963 Bostock
 3,382,928 A 5/1968 Phillips et al.
 3,385,370 A 5/1968 Carter et al.
 3,434,550 A 3/1969 Townsend, Jr.
 3,498,674 A 3/1970 Matthews
 3,554,281 A 1/1971 Ecuier
 3,599,713 A 8/1971 Jenkins
 3,601,190 A 8/1971 Mott
 3,603,409 A 9/1971 Watkins
 3,675,678 A 7/1972 Lamping
 3,698,411 A 10/1972 Garrett
 3,815,673 A 6/1974 Bruce
 3,957,114 A 5/1976 Streich
 3,964,556 A 6/1976 Gearhart
 3,965,980 A 6/1976 Williamson
 3,967,679 A 7/1976 Liljestrang
 3,973,586 A 8/1976 Hill
 3,973,587 A 8/1976 Cochran
 3,987,848 A 10/1976 Canterbury
 4,072,166 A 2/1978 Tiraspolosky et al.
 4,091,881 A 5/1978 Maus
 4,099,583 A 7/1978 Maus
 4,129,184 A 12/1978 Parker
 4,147,221 A 4/1979 Iifrey
 4,270,569 A 6/1981 Reay et al.
 4,291,772 A 9/1981 Beynet
 4,364,407 A 12/1982 Hillard
 4,391,328 A 7/1983 Aumann
 4,393,930 A 7/1983 Ross et al.
 4,624,316 A 11/1986 Baldridge et al.
 4,625,755 A 12/1986 Reddoch
 4,658,905 A 4/1987 Burge
 4,813,495 A 3/1989 Leach
 4,895,214 A 1/1990 Schoeffler
 4,997,042 A 3/1991 Jordan et al.
 5,092,406 A 3/1992 McStravick
 5,123,436 A 6/1992 Koechlein et al.
 5,174,392 A 12/1992 Reinhardt
 5,191,939 A 3/1993 Stokley
 5,310,012 A 5/1994 Cendre
 5,479,988 A 1/1996 Appleton
 5,584,343 A 12/1996 Coone
 5,682,952 A 11/1997 Stokley
 5,918,673 A 7/1999 Hawkings
 5,924,490 A 7/1999 Stone
 5,971,079 A 10/1999 Mullins
 5,979,572 A 11/1999 Boyd
 6,125,930 A 10/2000 Moyes
 6,216,799 B1 4/2001 Gonzalez
 6,263,981 B1 7/2001 Gonzalez
 6,276,455 B1 8/2001 Gonzalez
 6,325,159 B1 12/2001 Peterman
 6,328,103 B1 12/2001 Palmiyyer et al.
 6,328,109 B1 12/2001 Pringle
 6,386,289 B1 5/2002 Patel
 6,390,190 B2 5/2002 Mullins
 6,401,823 B1 6/2002 Gonzalez et al.
 6,415,862 B1 7/2002 Mullins
 6,435,282 B1 8/2002 Robison et al.
 6,488,092 B1 12/2002 Schoeffler
 6,536,540 B2 3/2003 De Boer
 6,540,020 B1 4/2003 Falgout, Sr.
 6,547,007 B2 4/2003 Szarka et al.
 6,571,876 B2 6/2003 Szarka
 6,585,051 B2 7/2003 Purkis et al.
 6,604,578 B2 8/2003 Mullins
 6,666,273 B2* 12/2003 Laurel 166/382
 6,675,889 B1 1/2004 Mullins
 6,705,404 B2 3/2004 Bosley
 6,715,542 B2 4/2004 Mullins
 6,722,425 B2 4/2004 Mullins

6,779,599 B2 8/2004 Mullins
 6,836,218 B2 12/2004 Frey et al.
 6,843,331 B2 1/2005 De Boer
 6,866,104 B2* 3/2005 Stoesz et al. 173/1
 6,926,101 B2 8/2005 De Boer
 6,966,392 B2 11/2005 De Boer
 7,013,980 B2 3/2006 Purkis et al.
 7,090,036 B2 8/2006 De Boer
 7,093,662 B2 8/2006 De Boer
 7,168,493 B2 1/2007 Eddison
 7,299,880 B2 11/2007 Logiudice
 7,373,972 B2 5/2008 Ocalan
 7,575,051 B2* 8/2009 Stoesz et al. 166/177.6
 7,584,801 B2 9/2009 De Boer
 7,984,763 B2* 7/2011 Carter et al. 166/327
 2001/0007284 A1 7/2001 French
 2001/0045290 A1 11/2001 Pringle et al.
 2002/0014338 A1 2/2002 Purkis et al.
 2002/0020558 A1 2/2002 Gonzalez et al.
 2002/0079104 A1 6/2002 Garcia
 2003/0098163 A1 5/2003 Hebert et al.
 2003/0116325 A1 6/2003 Cook et al.
 2004/0084213 A1 5/2004 De Boer
 2004/0129423 A1 7/2004 Eddison
 2006/0011354 A1 1/2006 Logiudice
 2006/0070772 A1* 4/2006 deBoer 175/70
 2006/0124352 A1 6/2006 Krueger et al.
 2006/0237187 A1* 10/2006 Stoesz et al. 166/177.6
 2007/0009737 A1 1/2007 Konno
 2007/0012442 A1 1/2007 Heam
 2007/0084607 A1 4/2007 Wright
 2007/0246265 A1 10/2007 DeBoer
 2008/0083541 A1 4/2008 Butterfield et al.
 2008/0302569 A1 12/2008 De Boer
 2008/0302570 A1 12/2008 De Boer
 2009/0211814 A1 8/2009 De Boer
 2009/0229828 A1* 9/2009 Ross 166/319
 2010/0044054 A1 2/2010 De Boer

FOREIGN PATENT DOCUMENTS

EP 0449768 A1 10/1991
 GB 2147641 A 5/1985
 GB 2236783 A 4/1991
 GB 2245623 A 1/1992
 GB 2251446 A 7/1992
 GB 2273514 A 6/1994
 GB 2314106 A 12/1997
 GB 2342935 A 4/2000
 GB 2377464 A 1/2003
 GB 2378970 A 2/2003
 GB 2457497 A 8/2009
 WO 93/11336 A1 6/1993
 WO 96/30621 A1 10/1996
 WO 99/15758 A2 4/1999
 WO 99/49172 A1 9/1999
 WO 02/075104 A1 9/2002
 WO 2004/033845 A2 4/2004
 WO 2004/044366 5/2004
 WO 2004/083596 9/2004
 WO 2005/062749 7/2005
 WO 2006/000799 A2 1/2006
 WO 2007124097 11/2007
 WO 2007/139581 12/2007

OTHER PUBLICATIONS

Stanislawek, Mikolaj, Analysis of Alternative Well Control Methods for Dual Density Deepwater Drilling Thesis Statement submitted to Louisiana State University, May 2005, 1-96.
 Shelton, John, Experimental Investigation of Drilling Fluid Formulations and Processing Methods for a Riser Dilution Approach to Dual Density Drilling, Thesis Statement Submitted to Louisiana State University, Dec. 2005, 1-110.
 Brainard, R.R., A Process Used in Evaluation of Managed-Pressure Drilling Candidates and Probabilistic Cost-Benefit Analysis, OTC 18375, May 1-4, 2008, Houston, Texas.
 Kennedy, John, First Dual Gradient Drilling System Set for Field Test, Drilling Contractor, May/June 2001.

(56)

References Cited

OTHER PUBLICATIONS

Rehm, Bill et al., *Managed Pressure Drilling*, 2008, 1-30, Gulf Publishing Company, Houston, Texas.

Smith, K.L. et al., *Subsea Mudlift Drilling JIP: Achieving Dual-Gradient Technology*, Deepwater Technology, Aug. 21-28, 1999, Gulf Publishing Company, Houston, Texas.

GB0802856.5; UK Search Report under Section 17, date of search May 14, 2008.

GB0802856.5; UK Search Report under Section 17, date of search Jul. 29, 2008.

Non-Final Office Action dated Aug. 19, 2013, U.S. Appl. No. 13/858,579, filed Apr. 8, 2013, pp. 1-54.

Non-Final Office Action dated Jan. 16, 2013, U.S. Appl. No. 12/867,595, filed Oct. 29, 2010, pp. 1-11.

Non-Final Office Action dated Mar. 28, 2012, U.S. Appl. No. 12/1867,595, filed Oct. 29, 2011, pp. 1-45.

Athina Nickitas-Etienne (Authorized Officer), International Preliminary Report on Patentability and Written Opinion of the International Searching Authority dated Feb. 21, 2012, PCT Application No. PCT/GB2009/002016, filed Aug. 18, 2009, pp. 1-6.

* cited by examiner

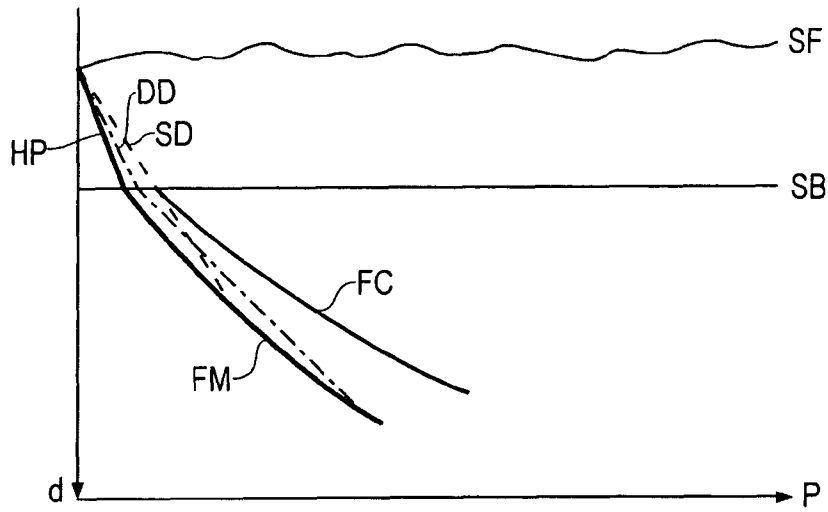

FIG. 1a

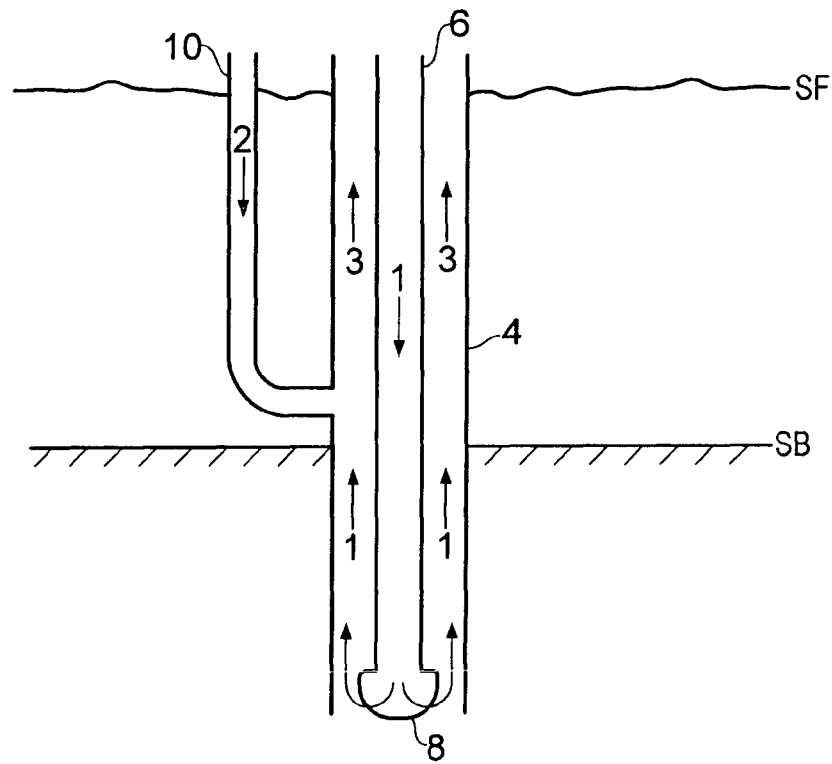

FIG. 1b

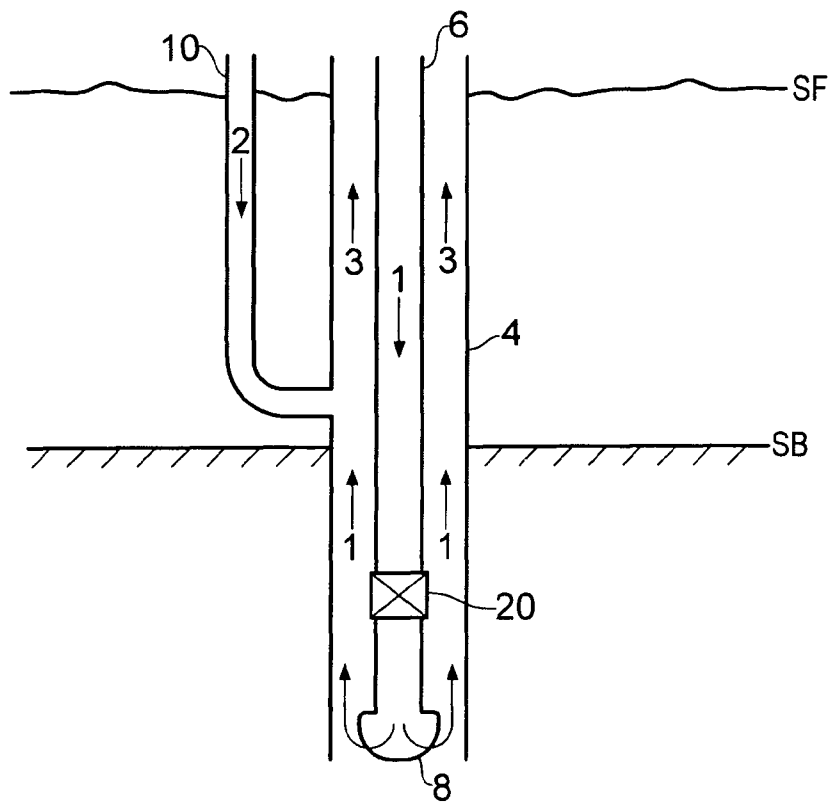

FIG. 1c

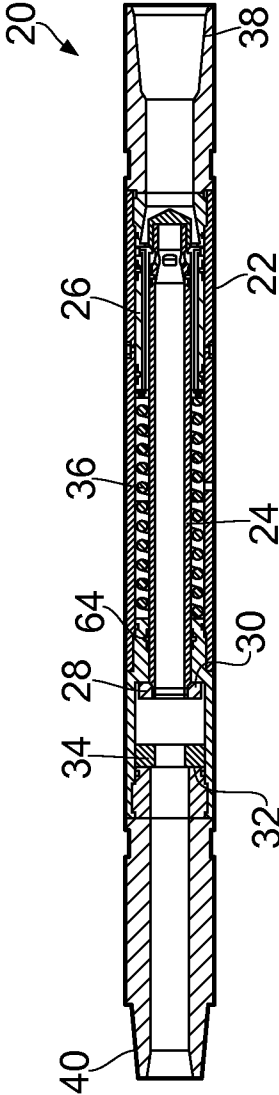

FIG. 2

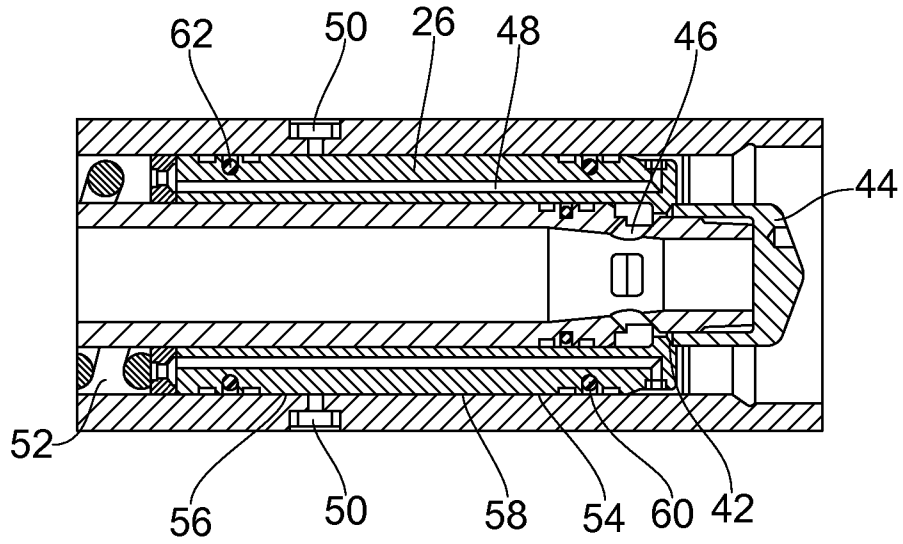

FIG. 3a

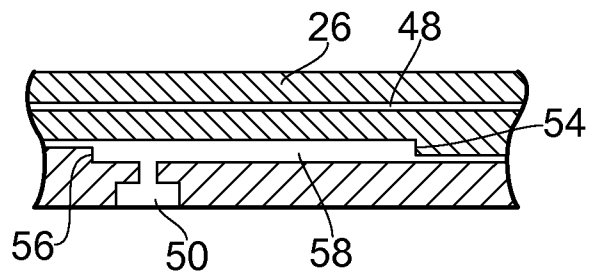

FIG. 3b

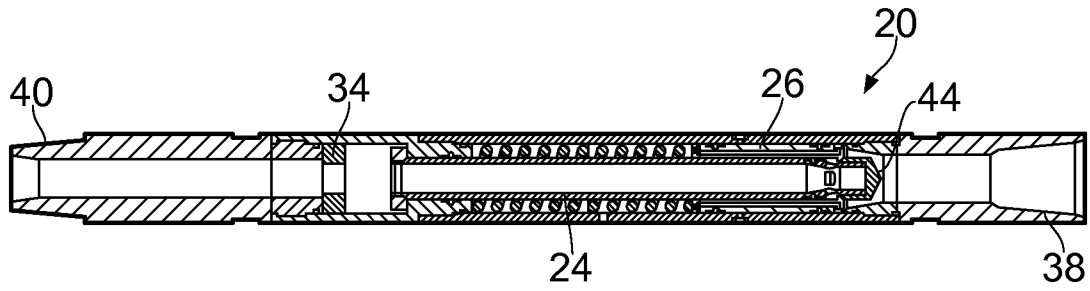

FIG. 4a

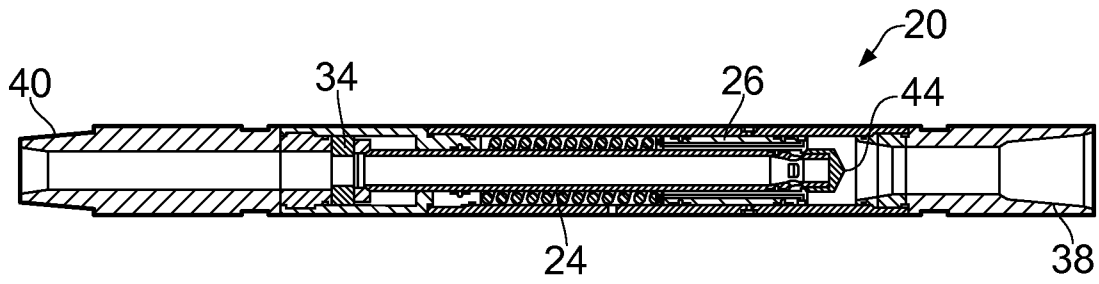

FIG. 4b

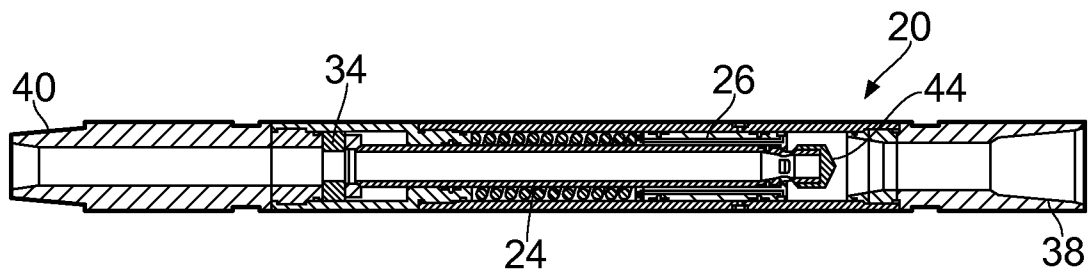

FIG. 4c

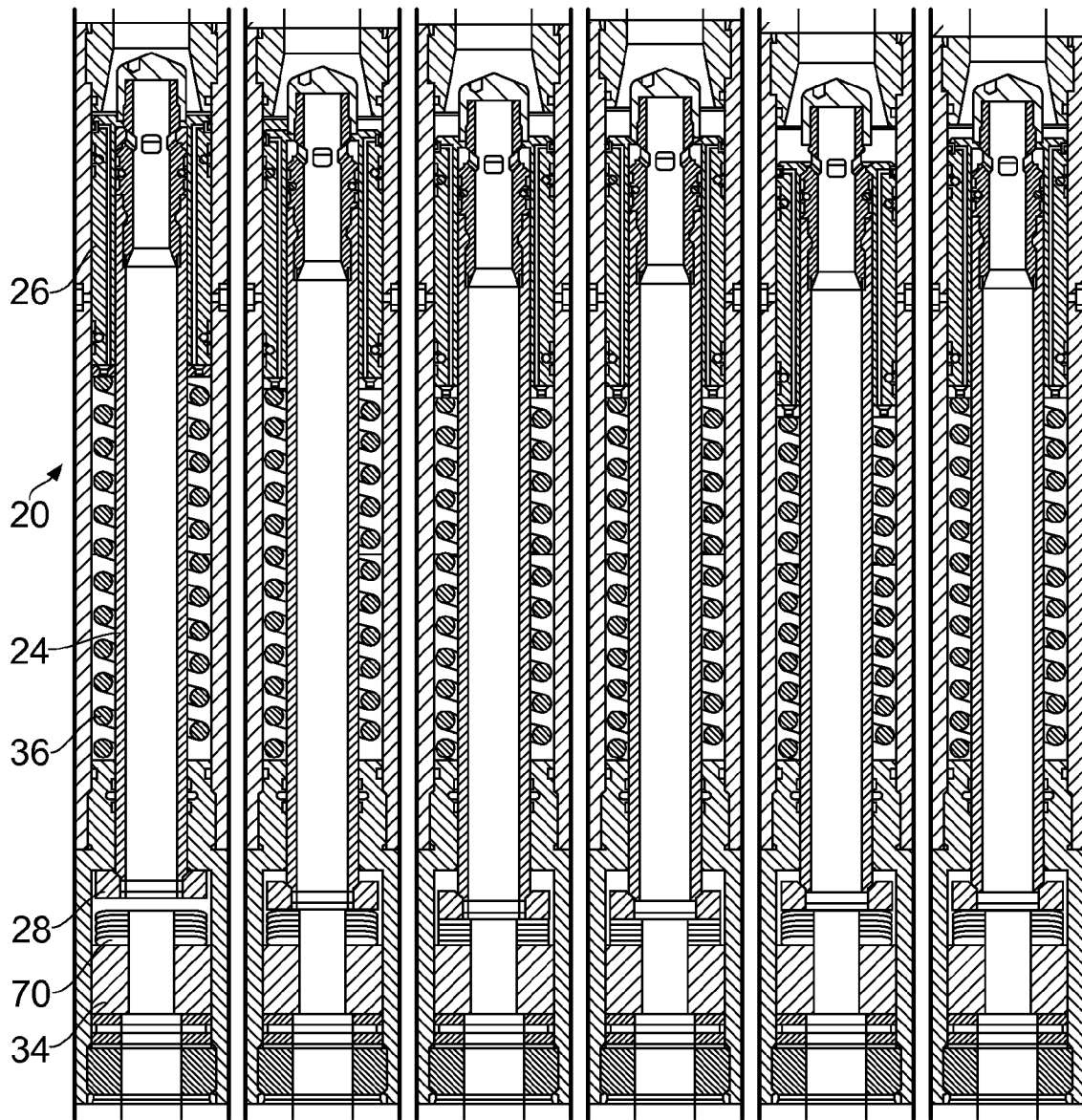

FIG. 5a

FIG. 5b

FIG. 5c

FIG. 5d

FIG. 5e

FIG. 5f

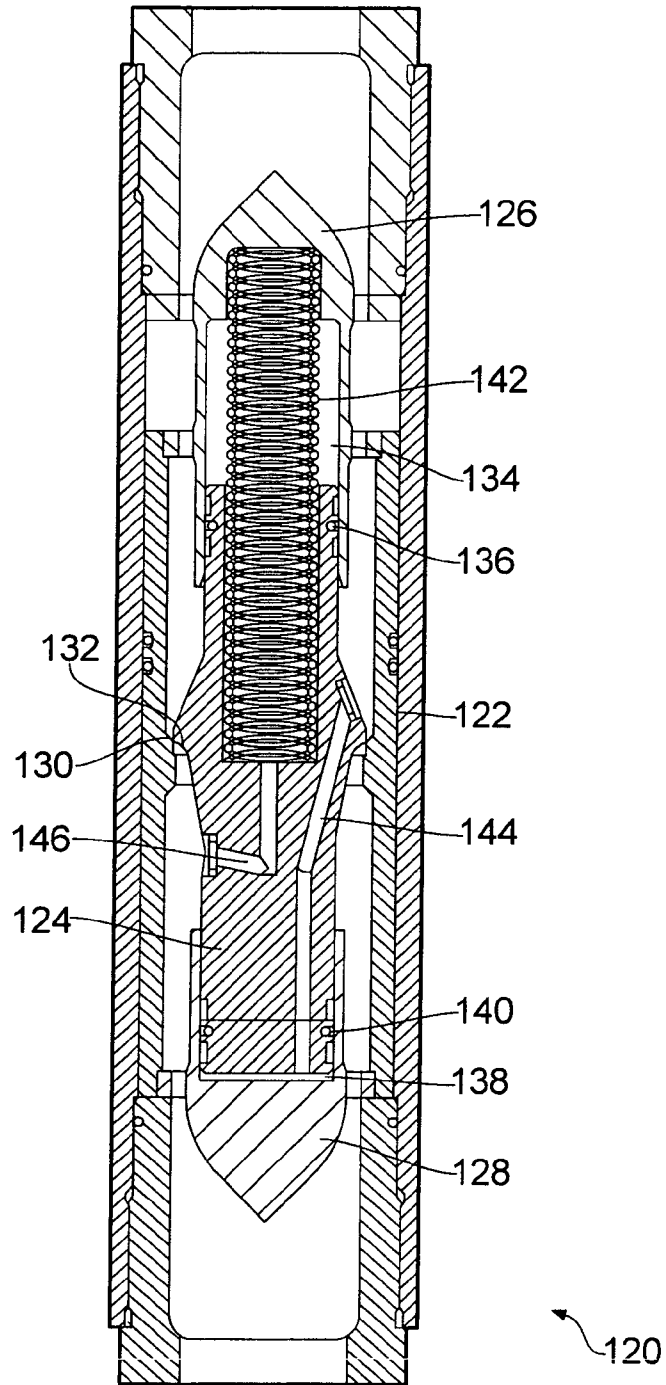

FIG. 6

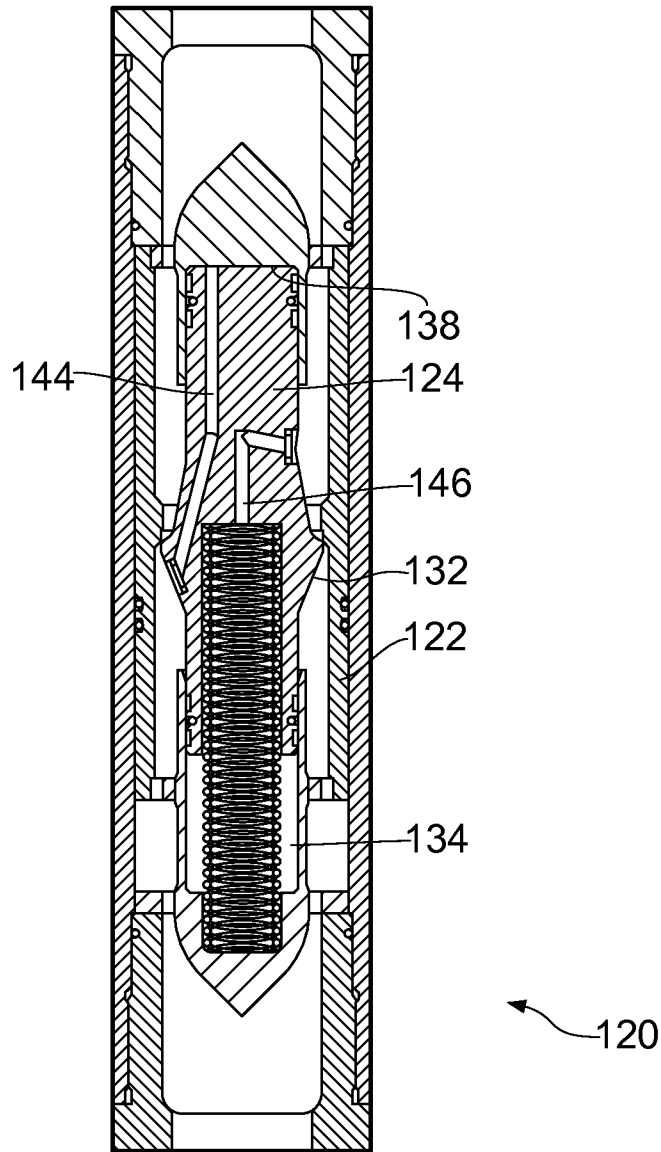

FIG. 7

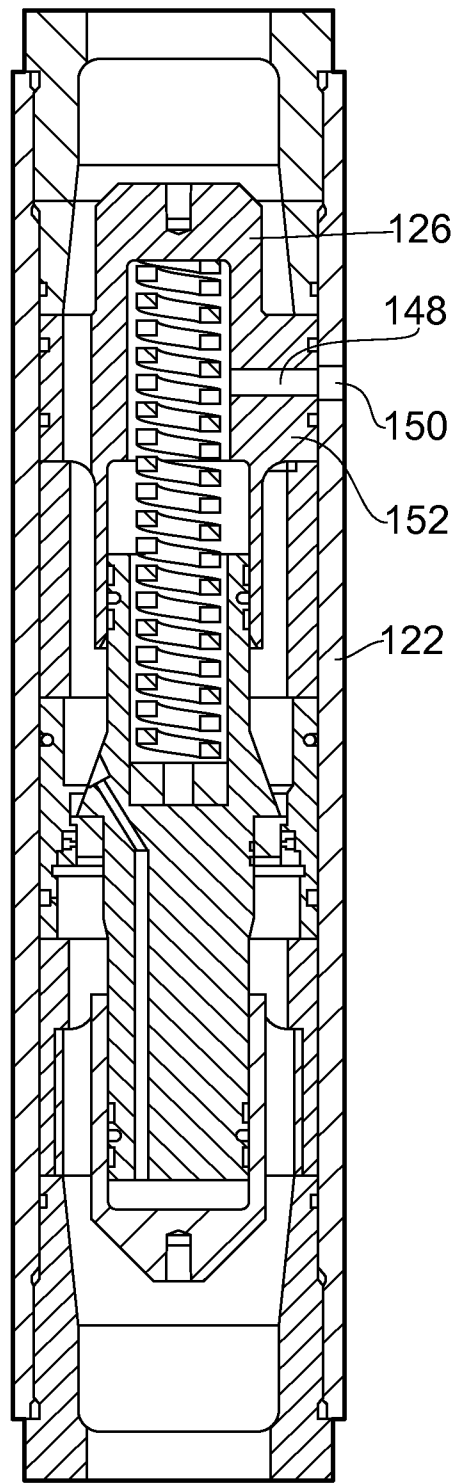

FIG. 8

1

FLOW STOP VALVE

CROSS-REFERENCE TO RELATED APPLICATION

This application is a divisional of U.S. patent application Ser. No. 12/867,595, filed on Oct. 29, 2010. The entirety of this priority document is incorporated herein by reference.

This disclosure relates to a flow stop valve which may be positioned in a downhole tubular, and particularly relates to a flow stop valve for use in dual density drilling fluid systems.

BACKGROUND

When drilling a well bore, it is desirable for the pressure of the drilling fluid in the newly drilled well bore, where there is no casing, to be greater than the local pore pressure of the formation to avoid flow from, or collapse of, the well wall. Similarly, the pressure of the drilling fluid should be less than the fracture pressure of the well to avoid well fracture or excessive loss of drilling fluid into the formation. In conventional onshore (or shallow offshore) drilling applications, the density of the drilling fluid is selected to ensure that the pressure of the drilling fluid is between the local formation pore pressure and the fracture pressure limits over a wide range of depths. (The pressure of the drilling fluid largely comprises the hydrostatic pressure of the well bore fluid with an additional component due to the pumping and resultant flow of the fluid.) However, in deep sea drilling applications the pressure of the formation at the seabed SB is substantially the same as the hydrostatic pressure HP of the sea at the seabed and the subsequent rate of pressure increase with depth d is different from that in the sea, as shown in FIG. 1a (in which P represents pressure and FM and FC denote formation pressure and fracture pressure respectively). This change in pressure gradient makes it difficult to ensure that the pressure of the drilling fluid is between the formation and fracture pressures over a range of depths, because a single density SD drilling fluid does not exhibit this same step change in the pressure gradient.

To overcome this difficulty, shorter sections of a well are currently drilled before the well wall is secured with a casing. Once a casing section is in place, the density of the drilling fluid may be altered to better suit the pore pressure of the next formation section to be drilled. This process is continued until the desired depth is reached. However, the depths of successive sections are severely limited by the different pressure gradients, as shown by the single density SD curve in FIG. 1a, and the time and cost to drill to a certain depth are significantly increased.

In view of these difficulties, dual density DD drilling fluid systems have been proposed (see US2006/0070772 and WO2004/033845 for example). Typically, in these proposed systems, the density of the drilling fluid returning from the wellbore is adjusted at or near the seabed to approximately match the density of the seawater. This is achieved by pumping to the seabed a second fluid with a different density and mixing this fluid with the drilling fluid returning to the surface. FIG. 1b shows an example of such a system in which a first density fluid 1 is pumped down a tubular 6 and through a drilling head 8. The first density fluid 1 and any cuttings from the drilling process then flow between the well wall and the tubular. Once this fluid reaches the seabed, it is mixed with a second density fluid 2, which is pumped from the surface SF via pipe 10. This mixing process results in a third density fluid 3, which flows to the surface within a riser 4, but is also outside the tubular 6. The fluids and any drilling cuttings are

2

then separated at the surface and the first and second density fluids are reformed for use in the process.

In alternative proposed systems, a single mixture is pumped down the tubular and when returning to the surface the mixture is separated into its constituent parts at the seabed. These separate components are then returned to the surface via the riser 4 and pipe 10, where the mixture is reformed for use in the process.

With either of the dual density arrangements, the density of the drilling fluid below the seabed is substantially at the same density as the fluid within the tubular and the density of the first and second density fluids may be selected so that the pressure of the drilling fluid outside the tubular and within the exposed well bore is between the formation and fracture pressures.

Such systems are desirable because they recreate the step change in the hydrostatic pressure gradient so that the pressure gradient of the drilling fluid below the seabed may more closely follow the formation and fracture pressures over a wider range of depths (as shown by the dual density DD curve in FIG. 1a). Therefore, with a dual density system, greater depths may be drilled before having to case the exposed well bore or adjust the density of the drilling fluid and significant savings may be made. Furthermore, dual density systems potentially allow deeper depths to be reached and hence greater reserves may be exploited.

However, one problem with the proposed dual density systems is that when the flow of drilling fluid stops, there is an inherent hydrostatic pressure imbalance between the fluid in the tubular and the fluid outside the tubular, because the fluid within the tubular is a single density fluid which has a different hydrostatic head to the dual density fluid outside the tubular. There is therefore a tendency for the denser drilling fluid in the tubular to redress this imbalance by displacing the less dense fluid outside the tubular, in the same manner as a U-tube manometer. The same problem also applies when lowering casing sections into the well bore.

Despite there being a long felt need for dual density drilling, the above-mentioned problem has to-date prevented the successful exploitation of dual density systems and the present disclosure aims to address this issue, and to reduce greatly the cost of dual density drilling.

STATEMENTS OF INVENTION

According to one embodiment of the invention, there is provided a flow stop valve positioned in a downhole tubular, wherein: the flow stop valve is in a closed position when a pressure difference between fluid outside the downhole tubular and inside the downhole tubular immediately above or at the flow stop valve is below a threshold value, thereby preventing flow through the downhole tubular; and the flow stop valve is in an open position when the pressure difference between fluid outside the downhole tubular and inside the downhole tubular immediately above or at the flow stop valve is above a threshold value, thereby permitting flow through the downhole tubular.

The threshold value for the pressure difference between fluid outside the tubular and inside the downhole tubular at the flow stop valve may be variable.

The flow stop valve may comprise: a first biasing element; and a valve; wherein the first biasing element may act on the valve such that the first biasing element may bias the valve towards the closed position; and wherein the pressure difference between fluid outside the downhole tubular and inside the tubular may also act on the valve and may bias the valve towards an open position, such that when the pressure differ-

ence exceeds the threshold value the valve may be in the open position and drilling fluid may be permitted to flow through the downhole tubular. The first biasing element may comprise a spring.

The flow stop valve may further comprise a housing, and a hollow tubular section and a sleeve located within the housing, the sleeve may be provided around the hollow tubular section and the sleeve may be located within the housing, the housing may comprise first and second ends and the hollow tubular section may comprise first and second ends, the first end of the hollow tubular section corresponding to the first end of the housing, and the second end of the hollow tubular section corresponding to a second end of the housing.

The hollow tubular section may be slidably engaged within the housing. The sleeve may be slidably engaged about the hollow tubular section.

The hollow tubular section may comprise a port such that the port may be selectively blocked by movement of the hollow tubular section or sleeve, the port may form the valve such that in an open position a flow path may exist from a first end of the housing, through the port and the centre of the tubular section to a second end of the housing.

A third abutment surface may be provided at a first end of the hollow tubular section such that the third abutment surface may limit the travel of the sleeve in the direction toward the first end of the housing. A flange may be provided at the second end of the hollow tubular section. A second abutment surface may be provided at the second end of the housing such that the second abutment surface of the housing may abut the flange of the tubular section limiting the travel of the hollow tubular section in a second direction, the second direction being in a direction towards the second end of the housing.

A first abutment surface may be provided within the housing between the second abutment surface of the housing and the first end of the housing, such that the first abutment surface may abut the flange of the hollow tubular section limiting the travel of the hollow tubular section in a first direction, the first direction being in a direction towards the first end of the housing.

A spacer element of variable dimensions may be provided between the second abutment surface of the housing and the flange of the hollow tubular section, such that the limit on the travel of the hollow tubular section in the second direction may be varied.

A second biasing element may be provided between the second abutment surface of the housing and the flange of the hollow tubular section. The second biasing element may comprise a spring.

The first biasing element may be provided about the hollow tubular section and the first biasing element may be positioned between the first abutment surface of the housing and the sleeve such that it may resist movement of the sleeve in the second direction.

A piston head may be provided at the first end of the hollow tubular section. Fluid pressure at the first end of the housing may act on the piston head and an end of the sleeve facing the first end of the housing. The projected area of the piston head exposed to the fluid at the first end of the housing may be greater than the projected area of the sleeve exposed to the fluid at the first end of the housing.

The sleeve, housing, hollow tubular section and first abutment surface may define a first chamber, such that when the valve is closed, the first chamber may not be in flow communication with the second end of the housing. A passage may be provided through the sleeve, the passage may provide a flow path from the first end of the housing to the first chamber. The projected area of the sleeve facing the fluid in the first end

of the housing is greater than the projected area of the sleeve facing the fluid in the first chamber.

A second chamber may be provided between the sleeve and the housing, the chamber may be sealed from flow communication with the first end of the housing and the first chamber. A fourth abutment surface may be provided on an outer surface of the sleeve and a fifth abutment surface may be provided within the housing, such that the fourth and fifth abutment surfaces may define the second chamber and limit the movement of the sleeve in the direction toward the second end of the housing.

A vent may be provided in the housing wall, the vent may provide a flow path between the second chamber and outside the housing of the flow stop valve. The surface of the sleeve defined by the difference between: the projected area of the sleeve facing the fluid in the first end of the housing; and the projected area of the sleeve facing the fluid in the first chamber, may be exposed to the fluid outside the flow stop valve.

A pressure difference between fluid on a first side of the valve and on a second side of the valve may be substantially the same as the pressure difference between fluid outside the downhole tubular and inside the downhole tubular immediately above the flow stop valve.

The flow stop valve may comprise: a third biasing element; and a valve; wherein the third biasing element may act on the valve such that the third biasing element may bias the valve towards the closed position; and wherein the pressure difference between fluid on a first side of the valve and on a second side of the valve may also act on the valve and bias the valve towards an open position, such that when the pressure difference exceeds the threshold value the valve may be in the open position and drilling fluid is permitted to flow through the downhole tubular.

The flow stop valve may further comprise a housing, and a spindle, the spindle may be located within the housing, and may be slidably received in a first receiving portion at a first end of the housing and a second receiving portion at a second end of the housing, the housing may comprise a first abutment surface and the spindle may comprise a second abutment surface, such that the valve may be in a closed position when the second abutment surface of the spindle engages the first abutment surface of the housing.

The spindle may comprise first and second ends, the first end of the spindle corresponding to the first end of the housing, and the second end of the spindle corresponding to a second end of the housing.

The first end of the spindle and the first receiving portion may define a first chamber and the second end of the spindle and the second receiving portion may define a second chamber, the first and second chambers may not be in flow communication with first and second ends of the housing. The third biasing element may comprise a spring provided in the first chamber.

There may be provided a first passage through the spindle from the first end of housing to the second chamber and a second passage through the spindle from the second end of the housing to the first chamber, such that the first chamber may be in flow communication with the second end of the housing and the second chamber may be in flow communication with the first end of the housing.

There may be provided a first passage through the spindle from the first end of housing to the second chamber and a second passage from a hole in a side wall of the housing to the first chamber, such that the first chamber may be in flow communication with fluid outside the downhole tubular and the second chamber may be in flow communication with the first end of the housing.

5

The projected area of the first end of the spindle facing the fluid in the first chamber may be less than the projected area of the second end of the spindle facing the fluid in the second chamber.

One or more of the spindle, the first receiving portion and the second receiving portion may be manufactured from drillable materials. One or more of the spindle, the first receiving portion and the second receiving portion may be manufactured from a selection of materials including brass and aluminium.

The flow stop valve may be for use in, for example, drilling and cementing and may be used to control the flow of completion fluids in completion operations. The flow stop valve may be for use in offshore deep sea applications. In such applications, the downhole tubular may extend, at least partially, from the surface to a seabed. The downhole tubular may be, at least partially, located within a riser, the riser extending from the seabed to the surface. The threshold value may be greater than or equal to the pressure difference between the fluid outside the tubular and inside the downhole tubular at the seabed. The first end of the housing may be located above the second end of the housing, the first end of the housing may be connected to a drillstring or casing section and the second end of the housing may be connected to another drillstring or casing section or a drilling device.

The fluid in the downhole tubular may be at a first density. A fluid at a second density may be combined at the seabed with fluid returning to the surface, so that the resulting mixture between the riser and downhole tubular may be at a third density.

According to another embodiment, there is provided a method for preventing flow in a downhole tubular, wherein when a difference between the pressure of fluid outside the downhole tubular and the pressure of fluid inside the downhole tubular at a flow stop valve is below a threshold value, the flow stop valve is in a closed position, preventing flow through the downhole tubular, and when a difference between the pressure of fluid outside the downhole tubular and the pressure of fluid inside the downhole tubular at the flow stop valve is above a threshold value, the flow stop valve is in an open position, permitting flow through the downhole tubular.

According to another embodiment, there is provided a method for preventing flow in a downhole tubular, wherein when a difference between the pressure of fluid on a first side of a flow stop valve and the pressure of fluid on a second side of the flow stop valve is below a threshold value, the flow stop valve is in a closed position, preventing flow through the downhole tubular, and when a difference between the pressure of fluid on a first side of the flow stop valve and the pressure of fluid on a second side of the flow stop valve is above a threshold value, the flow stop valve is in an open position, permitting flow through the downhole tubular.

The method may comprise drilling in a dual fluid density system with the flow stop valve disposed in a drill string. The method may comprise cementing in a dual fluid density system with the flow stop valve disposed adjacent to a casing section. The flow stop valve may be provided in a shoe of a casing string.

According to another embodiment, there is provided a method for drilling in a dual fluid density system using a valve, the valve preventing flow in a downhole tubular, wherein when a difference between the pressure of fluid outside the downhole tubular and the pressure of fluid inside the downhole tubular at a flow stop valve is below a threshold value, the flow stop valve is in a closed position, preventing flow through the downhole tubular, and when a difference between the pressure of fluid outside the downhole tubular

6

and the pressure of fluid inside the downhole tubular at the flow stop valve is above a threshold value, the flow stop valve is in an open position, permitting flow through the downhole tubular.

According to a further embodiment, there is provided a method for drilling in a dual fluid density system using a valve, the valve preventing flow in a downhole tubular, wherein when a difference between the pressure of fluid on a first side of a flow stop valve and the pressure of fluid on a second side of the flow stop valve is below a threshold value, the flow stop valve is in a closed position, preventing flow through the downhole tubular, and when a difference between the pressure of fluid on a first side of the flow stop valve and the pressure of fluid on a second side of the flow stop valve is above a threshold value, the flow stop valve is in an open position, permitting flow through the downhole tubular.

BRIEF DESCRIPTION OF THE DRAWINGS

For a better understanding of the present disclosure, and to show more clearly how it may be carried into effect, reference will now be made, by way of example, to the following drawings, in which:

FIG. 1a is a graph showing the variation of a formation and fracture pressures beneath the seabed;

FIG. 1b is a schematic diagram showing a proposed arrangement for one embodiment of a dual density drilling system;

FIG. 1c is a schematic diagram showing the positional arrangement of the flow stop valve according to a first embodiment of the disclosure;

FIG. 2 is a sectional side-view of the flow stop valve according to a first embodiment of the disclosure;

FIGS. 3a and 3b are sectional side-views showing the valve sleeve according to a first embodiment of the disclosure with FIG. 3b being an enlarged view of FIG. 3a;

FIGS. 4a, 4b and 4c are sectional side-views of the flow stop valve in the closed, pre-loaded and open positions according to a first embodiment of the disclosure;

FIGS. 5a, 5b, 5c, 5d, 5e and 5f are sectional side-views of the flow stop valve according to a second embodiment of the disclosure.

FIG. 6 is a sectional side-view of the flow stop valve according to a third embodiment of the disclosure;

FIG. 7 is a sectional side-view of the flow stop valve according to a fourth embodiment of the disclosure; and

FIG. 8 is a sectional side view of the flow stop valve according to a fifth embodiment of the disclosure.

DETAILED DESCRIPTION

With reference to FIG. 1c, a flow stop valve 20, according to a first embodiment of the disclosure, is located in a tubular 6 (e.g., a drillstring or casing string) such that, when a drilling head 8 is in position for drilling, the flow stop valve 20 is at any desired point in the tubular, for example, between the seabed SB and the drilling head 8. The illustrated flow stop valve 20 ensures that before the flow of drilling fluid 1 is started, or when it is stopped, the drilling fluid within the tubular 6 is restricted from flow communication with the fluid 1, 3 outside the tubular, thereby preventing uncontrollable flow due to the hydrostatic pressure difference described above.

With reference to FIG. 2, the flow stop valve 20, according to the first embodiment of the disclosure, comprises a tubular housing 22 within which there is disposed a hollow tubular section 24. The housing 22 comprises a box 38 at a first end of

the housing and a pin **40** at a second end of the housing. (NB, the first end of a component will hereafter refer to the rightmost end as shown in FIGS. **2-4** and accordingly the second end will refer to the leftmost end.) The box **38** and pin **40** allow engagement of the flow stop valve **20** with adjacent sections of a tubular and may comprise conventional box and pin threaded connections, respectively. Although the terms “box” and “pin” are used, any connection to a tubular could be used, for example a socket and plug arrangement. Alternatively, the flow stop valve **20** could be unitary with the tubular **6**.

A sleeve **26** is slidably disposed within the housing **22** about a first end of the hollow tubular section **24**, such that the sleeve **26** may slide along the hollow tubular section **24** at its first end, and the sleeve **26** may also slide within the housing **22**. A flange **28** is provided at a second end of the hollow tubular section **24** and a first abutment shoulder **30** is provided within the housing **22** between the first and second ends of the hollow tubular section **24** such that the hollow tubular section **24** is slidably engaged within the innermost portion of the first abutment shoulder **30** and the motion of the hollow tubular section **24** in a first direction towards the first end of the housing is limited by the abutment of the flange **28** against the first abutment shoulder **30**. (NB, the first direction is hereafter a direction towards the rightmost end shown in FIGS. **2-4** and accordingly the second direction is towards the leftmost end.) A second abutment shoulder **32** is provided within the housing **22** and is placed opposite the first abutment shoulder **30**, so that the flange **28** is between the first and second abutment shoulders **30**, **32**. Furthermore, a variable width spacer element **34** may be placed between the second abutment shoulder **32** and the flange **28** and motion of the hollow tubular section **24** in a second direction towards the second end of the housing may be limited by the abutment of the flange **28** against the spacer element **34** and the abutment of the spacer element **34** against the second abutment shoulder **32**. The flange **28** and spacer element **34** may both have central openings so that the flow of fluid is permitted from the centre of the hollow tubular section **24** to the second end of the flow stop valve **20**.

The flow stop valve **20**, according to the first embodiment of the disclosure, may also be provided with a spring **36**, which is located between the first abutment shoulder **30** and the sleeve **26**. The illustrated spring **36** may resist motion of the sleeve **26** in the second direction.

With reference to FIGS. **3a** and **3b**, the hollow tubular section **24**, according to the first embodiment of the disclosure, further comprises a cone shaped piston head **44** disposed at the first end of the hollow tubular section **24**. The piston head **44** may be provided with a third abutment shoulder **42**, which abuts a first end of the sleeve **26** thereby limiting motion of the sleeve **26** relative to the hollow tubular section **24** in the first direction. The piston head **44** may be any desired shape. For example, it may be cone shaped as in the illustrated embodiment. The hollow tubular section **24** may further comprise one or more ports **46**, which may be provided in a side-wall of the hollow tubular section **24** at the first end of the hollow tubular section **24**. The ports **46** may permit flow from the first end of the flow stop valve **20** into the centre of the hollow tubular section **24**, through the openings in the flange **28** and spacer element **34** and subsequently to the second end of the flow stop valve **20**. However, when the sleeve **26** abuts the third abutment shoulder **42** of the piston head **44**, the sleeve **26** may block the ports **46** and hence prevents flow from the first end of the flow stop valve **20** to the centre of the hollow tubular section **24**.

The sleeve **26** may further comprise a sleeve vent **48** which provides a flow passage from the first end of the sleeve **26** to the second end of the sleeve **26** and thence to a first chamber **52**, which contains the spring **36** and is defined by the housing **22**, the hollow tubular section **24**, the first abutment shoulder **30** and the second end of the sleeve **26**. The sleeve vent **48** may thus ensure that the pressures acting on the first and second ends of the sleeve **26** are equal. However, the projected area of the first end of the sleeve **26** may be greater than the projected area of the second end of the sleeve **26** so that the force due to the pressure acting on the first end of the sleeve **26** is greater than the force due to the pressure acting on the second end of the sleeve **26**. This area difference may be achieved by virtue of a fourth abutment shoulder **54** in the sleeve **26** and a corresponding fifth abutment shoulder **56** in the housing **22**. The fourth abutment shoulder **54** may be arranged so that the diameter of the sleeve **26** at its first end is greater than that at its second end and furthermore, motion of the sleeve **26** in the second direction may be limited when the fourth and fifth abutment shoulders **54**, **56** abut. The fourth and fifth abutment shoulders **54**, **56**, together with the sleeve **26** and housing **22** may define a second chamber **58** and a housing vent **50** may be provided in the side-wall of the housing **22** so that the second chamber **58** may be in flow communication with the fluid outside the flow stop valve **20**. The net force acting on the sleeve **26** is therefore the product of (1) the difference between the pressure outside the flow stop valve **20** and at the first end of the flow stop valve **20**, and (2) the area difference between the first and second ends of the sleeve.

Seals **60**, **62** may be provided at the first and second ends of the sleeve **26** respectively so that the second chamber **58** may be sealed from the first end of the flow stop valve **20** and the first chamber **52** respectively. Furthermore, seals **64** may be provided on the innermost portion of the first abutment shoulder **30** so that the first chamber **52** may be sealed from the second end of the flow stop valve **20**.

With reference to FIGS. **4a**, **4b** and **4c**, operation of the flow stop valve **20**, according to the first embodiment of the disclosure, will now be explained. The flow stop valve **20** may be located in a tubular with the first end above the second end and the flow stop valve **20** may be connected to adjacent tubular sections via the box **38** and pin **40**. Prior to lowering of the tubular into the wellbore (e.g., the riser of an offshore drilling rig), there may be a small preload in the spring **36** so that the sleeve **26** abuts the third abutment shoulder **42** of the piston head **44** and the ports **46** are closed, as shown in FIG. **4a**. In this position no drilling fluid may pass through the flow stop valve **20**.

As the tubular and hence flow stop valve **20** is lowered into the riser, the hydrostatic pressures inside and outside the tubular and flow stop valve **20** begin to rise. With one embodiment of a dual density drilling fluid system, the density of the fluid within the tubular may be higher than the density of the fluid outside the tubular, and the hydrostatic pressures within the tubular (and hence those acting on the piston head **44** and first and second ends of the sleeve **26**) therefore increase at a greater rate than the pressures outside the tubular. The difference between the pressures inside and outside the tubular may increase until the seabed is reached, beyond which point the fluids inside and outside the tubular may have the same density and the pressures inside and outside the tubular may increase at the same rate.

Before the flow stop valve **20** reaches the seabed, the increasing pressure difference between the inside and outside of the tubular also acts on the hollow tubular section **24** because the top (first) end of the flow stop valve **20** is not in

flow communication with the bottom (second) end of the flow stop valve 20. This pressure difference acts on the projected area of the piston head 44, which in one embodiment may have the same outer diameter as the hollow tubular section 24. The same pressure difference may also act on the difference in areas between the first and second ends of the sleeve, however, this area difference may be smaller than the projected area of the piston head 44. Therefore, as the flow stop valve 20 is lowered into the riser, the force acting on the hollow tubular section 24 may be greater than the force acting on the sleeve 26. Once the forces acting on the hollow tubular section 24 and sleeve 26 overcome the small preload in the spring 36, the hollow tubular section 24 may be moved downwards (i.e., in the second direction) and because the force on the piston head 44 may be greater than that on the sleeve 26, the sleeve 26 remains abutted against the third abutment shoulder 42 of the piston head 44. This movement of the hollow tubular section 24 may continue until the flange 28 abuts the spacer element 34, at which point the flow stop valve 20 may be fully preloaded, as shown in FIG. 4b. The pressure difference at which this occurs, and the resulting force in the spring, may be varied by changing the thickness of the spacer element 34. With a larger spacer element 34 the hollow tubular section 24 may travel a shorter distance before the flow stop valve 20 is preloaded and may result in a smaller spring force. The opposite applies for a smaller spacer element 34. (The size of the spacer element 34 may be selected before installing the flow stop valve 20 into the tubular.)

When the hollow tubular section 24 cannot move any further the flow stop valve 20 is in a fully preloaded state. However, in the fully preloaded state, the force acting on the sleeve 26 is not yet sufficient to overcome the spring force, because the pressure difference acting on the sleeve 26 acts on a much smaller area. The sleeve 26 may therefore remain in contact with the third abutment shoulder 42 and the ports 46 may stay closed. The flow stop valve 20 may be lowered further for the pressure difference acting on the sleeve 26 to increase. The spacer element 34 thickness may be selected so that once the flow stop valve 20 reaches the seabed, the pressure difference and hence pressure forces acting on the sleeve 26 at this depth are just less than the spring force in the fully preloaded state. At the seabed the pressure forces are therefore not sufficient to move the sleeve 26, but a further increase, which may be a small increase, in the pressure upstream of the flow stop valve may be sufficient to overcome the spring force in the fully preloaded state and move the sleeve 26. However, as the flow stop valve 20 is lowered below the seabed, the pressure difference may not increase any more (for the reasons explained above) and hence the ports 46 will remain closed. Once the tubular is in place and the flow of drilling fluid is desired, an additional “cracking” pressure may be applied by the drilling fluid pumps, which may be sufficient to overcome the fully preloaded spring force, thereby moving the sleeve 26 downwards (in the second direction) and permitting flow through the ports 46 and the flow stop valve 20.

By preventing flow until the drilling fluid pumps provide the “cracking” pressure, the flow stop valve 20 described above may solve the aforementioned problem of the fluid in the tubular displacing the fluid outside the tubular due to the density differences and resulting hydrostatic pressure imbalances.

In an alternative embodiment, the flange 28 may be replaced with a tightening nut disposed about the second end of the hollow tubular section 24, so that the initial length of the

spring 36, and hence the fully preloaded spring force, may be varied at the surface. With such an arrangement, the spacer element 34 may be removed.

With reference to FIGS. 5a-f, a flow stop valve 20, according to a second embodiment of the disclosure, may further comprise a second spring 70 disposed between the flange 28 and spacer element 34. The second spring 70 may fit within the housing 22 and the second spring 70 may be sized to allow the passage of fluid through the flow stop valve 20. For example, the inner diameter of the second spring 70 may be greater than, or equal to, the inner diameter of the hollow tubular section 24 and/or the spacer element 34. In an uncompressed state, the second spring 70 may not contact the flange 28 when the hollow tubular section 24 is in its raised position (as shown in FIG. 5a). Alternatively, when in an uncompressed state the second spring 70 may at all times contact both the flange 28 and spacer element 34.

Operation of the second embodiment will now be explained with reference to FIGS. 5a-f, which show the various stages of the flow stop valve. FIG. 5a shows the flow stop valve 20 at the surface prior to lowering into the hole with the sleeve 26 and hollow tubular section 24 in their first-most directions. FIG. 5b shows the flow stop valve 20 as it is lowered into the hole and the higher pressure acting at the first end of the flow stop valve 20 causes the spring 36 to compress. When the flow stop valve 20 is lowered further into the hole, for example, as shown in FIG. 5c, the pressure differential acting across the sleeve 26 and hollow tubular section 24 increases. The spring 36 may be further compressed by the hollow tubular section 24 being forced in the second direction and, as the flange 28 comes into contact with the second spring 70, the second spring 70 may also be compressed. The pressure differential acting across the sleeve 26 and hollow tubular section 24 reaches a maximum value when the flow stop valve reaches the seabed and as the flow stop valve is lowered further below the sea bed the pressure differential remains substantially constant at this maximum value. This is because the hydrostatic pressure inside and outside the downhole tubular increase at the same rate due to the fluid densities below the sea bed being the same inside and outside the downhole tubular. Therefore, an additional “cracking” pressure is required to open the flow stop valve, and this additional cracking pressure may be provided by a dynamic pressure caused by the flow of fluid in the downhole tubular.

FIG. 5d shows the flow stop valve 20 at a depth below the seabed. Once the “cracking” pressure has been applied (for example by pumping fluid down the downhole tubular) the sleeve 26 may begin to move in the second direction and the ports 46 may be opened permitting flow through the flow stop valve 20. As the fluid begins to flow, the pressure difference acting across the hollow tubular section 24 may be reduced. The downward force acting on the hollow tubular section 24 may therefore also be reduced and the second spring 36 may then be able to force the hollow tubular section 24 upwards, i.e. in the first direction, as shown in FIG. 5e. Movement of the hollow tubular section 24 in the first direction may also cause the ports 46 to open more quickly. This may serve to further reduce the pressure drop across the flow stop valve 20, which may in turn further raise the hollow tubular section 24.

As shown in FIG. 5f, when the dynamic pressure upstream of the flow stop valve is reduced (for example by stopping the pumping of drilling fluid), the sleeve 26 returns to the first end of the hollow tubular section 24 closing the ports 46 and hence the flow stop valve 20.

The second spring 70 may be any form of biasing element and for example may be a coiled spring, disc spring, rubber spring or any other element exhibiting resilient properties.

11

The combined thickness of the spacer element **34** and the second spring **70** in a compressed state may determine the preloading in the spring **36** and hence the “cracking” pressure to open the flow stop valve **20**. In one embodiment, to obtain an appropriate cracking pressure for the desired depth, the thickness of the spacer element **34** and/or second spring **70** in a compressed state may be selected before installing the flow stop valve **20** into the tubular.

In an alternative to the second embodiment, a second spring **70** may completely replace the spacer element **34**, e.g., so that the second spring **70** may be located between the second abutment shoulder **32** and the flange **28**. In such an embodiment the preloading in the spring **36** may be determined by the length of the second spring **70** in a compressed state.

A flow stop valve according to a third embodiment of the disclosure relates to the lowering of a tubular and may in particular relate to the lowering of a casing section into a newly drilled and exposed portion of a well bore. The flow stop valve is located in a tubular being lowered into a well bore, such that, when a tubular is in position for sealing against the well wall, the flow stop valve is at any point in the tubular between the seabed and the bottom of the tubular. In particular, the flow stop valve **120** may be located at the bottom of a casing string, for example, at a casing shoe. The flow stop valve may ensure that before the flow of fluid, e.g., a cement slurry, is started, or when it is stopped, the fluid within the tubular is not in flow communication with the fluid outside the tubular, thereby preventing the flow due to the hydrostatic pressure difference described above. (The aforementioned problem of the hydrostatic pressure imbalance applies equally to cementing operations as the density of a cement slurry may be higher than a drilling fluid.)

With reference to FIG. 6, the flow stop valve **120**, according to the third embodiment of the disclosure, may comprise a housing **122** and a spindle **124**. The spindle **124** may be slidably received in both a first receiving portion **126** and a second receiving portion **128**. The first receiving portion **126** may be attached to a first end of the housing **122** and the second receiving portion **128** may be attached to a second end of the housing **122**. (NB, the first end of a component will hereafter refer to the topmost end as shown in FIG. 6 and accordingly the second end will refer to the bottommost end of the third embodiment) The attachments between the housing **122** and the first and second receiving portions **126**, **128** may be arranged such that a flow is permitted between the housing **122** and the first receiving portion **126** and the housing **122** and the second receiving portion **128**.

The housing further may comprise a first annular abutment surface **130**, which is located on the inner sidewall of the housing and between the first and second receiving portions **126**, **128**. The spindle **124** may also comprise a second annular abutment surface **132** and the second annular abutment surface may be provided between first and second ends of the spindle **124**. The arrangement of the first and second annular abutment surfaces **130**, **132** may permit motion of the spindle **124** in a first direction but may limit motion in a second direction. (NB, the first direction is hereafter a direction towards the topmost end shown in FIG. 6 and accordingly the second direction is towards the bottommost end of the third embodiment.) Furthermore, the second annular abutment surface **132** may be shaped for engagement with the first annular abutment surface **130**, such that when the first and second annular abutment surfaces abut, flow from first end of the flow stop valve **120** to the second end of the flow stop valve **120** may be prevented.

12

The first receiving portion **126** and first end of the spindle **124** together may define a first chamber **134**. Seals **136** may be provided about the first end of the spindle **124** to ensure that the first chamber **134** is not in flow communication with the first end of the flow stop valve **120**. Similarly, the second receiving portion **128** and the second end of the spindle **124** together define a second chamber **138**. Seals **140** may be provided about the second end of the spindle **124** to ensure that the second chamber **138** is not in flow communication with the second end of the flow stop valve **120**.

The projected area of the first and second ends of the spindle **124** in the first and second chambers **134**, **138** may be equal and the projected area of the second annular abutment surface **132** may be less than the projected area of the first and second ends of the spindle **124**.

A spring **142** may be provided in the first chamber **134** with a first end of the spring **142** in contact with the first receiving portion **126** and a second end of the spring **142** in contact with the spindle **124**. The spring **142** may bias the spindle **124** in the second direction such that the first and second abutment surfaces **130**, **132** abut. A spacer element (not shown) may be provided in the first chamber **134** between the spring **142** and spindle **124** or the spring **142** and first receiving portion **126**. The spacer element may act to reduce the initial length of the spring **142** and hence the pretension in the spring.

The spindle **124** may also be provided with a first passage **144** and a second passage **146**. The first passage **144** may provide a flow path from the first end of the flow stop valve **120** to the second chamber **138**, whilst the second passage **146** may provide a flow path from the second end of the flow stop valve **120** to the first chamber **134**. However, when the first annular abutment surface **130** abuts the second annular abutment surface **132**, the first passage **144** may not be in flow communication with the second passage **146**.

The flow stop valve **120** may be manufactured from Aluminium (or any other readily drillable material, for example brass) to allow the flow stop valve **120** to be drilled out once the cementing operation is complete. In addition, the spring **142** may be one or more Belleville washers or a wave spring; e.g., to allow the use of a larger spring section whilst still keeping it drillable. To assist in the drilling operation the flow stop valve **120** may be located eccentrically in an outer casing to allow it to be easily drilled out by a conventional drill bit. Furthermore, the flow stop valve **120** may be shaped to assist the fluid flows as much as possible and so reduce the wear of the flow stop valve **120** through erosion.

In operation the pressure from the first and second ends of the flow stop valve **120** acts on the second and first chambers **138**, **134** respectively via the first and second passages **144**, **146** respectively. The projected area of the first and second ends of the spindle **124** in the first and second chambers **134**, **138** may be equal, but because the pressure in the first end of the flow stop valve **120** is higher than the pressure in the second end of the flow stop valve **120** (for example, when used with the dual density system explained above) the forces acting in the second chamber **138** are higher than those in the first chamber **134**. Furthermore, as the projected area of the second annular abutment surface **132** may be less than the projected area of the first and second ends of the spindle **124**, the net effect of the pressure forces is to move the spindle **124** in a first direction. However, the spring **142** may act on the spindle **124** to oppose this force and keep the flow stop valve **120** in a closed position (i.e. with the first and second annular abutment surfaces **130**, **132** in engagement). The spring **142** does may not support the complete pressure force, because the area in the first and second chambers **134**, **138** may be greater than that around the centre of the spindle **124** and the

net force acting on the first and second chambers **134**, **138** is in the opposite direction to the force acting on the second annular abutment surface **132**.

The opening of the flow stop valve **120** may occur when the pressure differential acting over the spindle **124** reaches the desired “cracking” pressure. At this pressure, the net force acting on the spindle **124** is enough to cause the spindle **124** to move in a first direction, thereby allowing cementing fluid to flow. The pressure difference at which this occurs may be varied by selecting an appropriate spacer element to adjust the pretension in the spring.

However, once fluid starts to flow through the flow stop valve **120**, the pressure difference acting across the spindle **124** may diminish, although a pressure difference may remain due to pressure losses caused by the flow of fluid through the valve. Therefore, in the absence of the pressure differences present when there is no flow, the spring **142** may act to close the valve. However, as the valve closes the pressure differences may again act on the spindle **124**, thereby causing it to re-open. This process may repeat itself and the spindle **124** may “chatter” during use. The oscillation between the open and closed positions assists in maintaining the flow of cementing fluid and these dynamic effects may help to prevent blockage between the first and second annular abutment surfaces **130**, **132**.

With reference to FIG. 7, the flow stop valve **120**, according to a fourth embodiment of the disclosure is substantially similar to the third embodiment of the disclosure, except that the flow stop valve **120** may be orientated in the opposite direction (i.e. the first end of the housing **122** is at the bottommost end and the second end of the housing **122** is at the topmost end). In addition, the fourth embodiment may differ from the third embodiment in that the projected area of the second annular abutment surface **132** may be greater than the projected area of the first and second ends of the spindle **124**. Aside from these differences the fourth embodiment is otherwise the same as the third embodiment and like parts have the same name and reference numeral.

During operation of the fourth embodiment, higher pressure fluid from above the flow stop valve **120** may act on the first chamber **134** by virtue of the second passage **146**, and lower pressure fluid may act on the second chamber **138** by virtue of first passage **144**. The pressure forces on the first and second chambers **134**, **138**, together with the spring force, may act to close the flow stop valve **120** (i.e. with the first and second annular abutment surfaces **130**, **132** in engagement). However, as the projected area of the first annular abutment surface **130** may be greater than the projected area of the first and second ends of the spindle **124**, the net effect of the pressure forces is to move the spindle **124** into an open position. Therefore, once the pressure forces have reached a particular threshold sufficient to overcome the spring force, the flow stop valve **120** may be open.

In alternative embodiments, the first and second ends of the spindle **124** may have different projected areas. For example, increasing the projected area of the first end of the spindle **124** for the third embodiment relative to the second end of the spindle **124**, may further bias the valve into a closed position and may hence increase the “cracking” pressure to open the valve. Other modifications to the projected areas may be made in order to change the bias of the valve, as would be understood by one skilled in the art.

With reference to FIG. 8, the flow stop valve **120**, according to a fifth embodiment of the disclosure is substantially similar to the third embodiment of the disclosure, except that the second passage **146** of the spindle **124** has been omitted. Instead, the first receiving portion **126** may be provided with

a third passage **148** which provides a flow passage from the first receiving portion **126** to the outside of the flow stop valve **120**. There may be a corresponding hole **150** in the housing **122**. The third passage **148** may be provided within a portion **152** of the first receiving portion **126** which extends to meet the inner surface of the housing **122**. However, a flow passage may still be maintained around the first receiving portion **126** such that a fluid may flow from the first end of the flow stop valve **120** to the second end of the flow stop valve **120**. Aside from these differences, the fifth embodiment is otherwise the same as the third embodiment and like parts have the same name and reference numeral.

The fifth embodiment works in the same way as the third embodiment because the fluid just below the flow stop valve and inside the downhole tubular has the same density as the fluid just below the flow stop valve and outside the downhole tubular (see FIG. 1*b*). Therefore, the hydrostatic pressure of the fluid outside the flow stop valve may be the same as that inside the downhole tubular just below the flow stop valve. (By contrast, the pressure of the fluid above the flow stop valve **120** may be different from that outside the flow stop valve **120** because the density of the fluid above the flow stop valve and inside the downhole tubular is different from the density of the fluid above the flow stop valve and outside the downhole tubular, as shown in FIG. 1*b*.) It therefore follows that, before the flow stop valve **120** opens, the pressure difference between fluid on the first and second sides of the valve may be substantially the same as the pressure difference between fluid inside and outside the valve at a point just above the valve (neglecting the hydrostatic pressure difference between above and below the valve outside of the valve as this may be relatively small in comparison to the depths involved). Thus, the fifth embodiment, which only differs from the third embodiment by tapping the pressure from outside the flow stop valve instead of below the flow stop valve for the first receiving portion **126**, may work in the same way as the third embodiment.

While the invention has been presented with respect to a limited number of embodiments, those skilled in the art, having benefit of this disclosure, will appreciate that other embodiments may be devised which do not depart from the scope of the present disclosure. Accordingly, the scope of the invention should be limited only by the attached claims.

The invention claimed is:

1. A flow stop valve positionable in a downhole tubular, the flow stop valve comprising:

a housing;

a valve selectively permitting fluid flow through the flow stop valve, the valve comprising a first valve element and a second valve element movably located within the housing, wherein the first valve element is movable with respect to the second valve element; and

a first biasing element acting on the valve,

wherein the valve is actuated between an open position and a closed position in response to a pressure difference acting on the valve, the pressure difference comprising a difference between a fluid pressure outside of the downhole tubular and a fluid pressure inside of the downhole tubular, or a difference between a fluid pressure at a first, uphole end of the housing and a fluid pressure at a second, downhole end of the housing, or both,

wherein the valve is in a closed position when the pressure difference is less than a threshold value and the valve is an open position when the pressure difference is greater than the threshold value,

wherein the first biasing element is preloaded by movement of the first and the second valve elements together

15

in response to an increase in the pressure difference in response to lowering the flow stop valve downhole, and wherein the second valve element comprises a port and a passage, the port being in fluidic communication with the passage such that a flow from the first end of the housing to the port is selectively blocked by movement of the second valve element or first valve element, or both, wherein when the valve is in the open position a flow path exists from the first end of the housing, through the port and the passage of the second valve element to the second end of the housing, and wherein, when the valve is in the closed position, the first valve element covers the port of the second valve element, such that the first valve element blocks the flow from the first end of the housing from proceeding to the port.

2. The flow stop valve of claim 1, wherein the valve stays in the closed position during further lowering of the flow stop valve until the pressure difference increases to above the threshold value and the first valve element moves relative to the second valve element.

3. The flow stop valve of claim 1, wherein the first and second valve elements each comprise at least one valve surface, wherein the valve surface of the first valve element and the valve surface of the second valve element are configured to selectively abut one another and prevent flow through the valve.

4. The flow stop valve of claim 1, wherein the flow stop valve further comprises an abutment surface, the abutment surface being configured to limit the travel of the second valve element.

5. The flow stop valve of claim 4, further comprising a spacer element having variable dimensions and configured to adjust a position of the abutment surface such that the limit on the travel of the second valve element can be varied.

6. The flow stop valve of claim 4, further comprising a second biasing element disposed between the abutment surface and the second valve element.

7. The flow stop valve of claim 1, wherein the first biasing element is positioned between an abutment surface of the housing and the first valve element such that the first biasing element resists movement of the first valve element.

8. The flow stop valve of claim 1, wherein the second valve element comprises a piston head provided at a first end of the second valve element.

9. The flow stop valve of claim 8, wherein a projected area of the piston head exposed to the fluid at the first end of the housing is greater than a projected area of the first valve element exposed to the fluid at the first end of the housing.

10. The flow stop valve of claim 1, wherein, when the valve is in the open position, the flow to the port flows radially inward therethrough and to the passage.

11. The flow stop valve of claim 1, wherein, when the valve is in the closed position, the first valve element blocks flow to the port of the second valve element at a point upstream from the port.

12. A flow stop valve positionable in a downhole tubular, comprising:

a housing;

a valve selectively permitting fluid flow through the flow stop valve, the valve comprising a first valve element and a second valve element movably located within the housing, wherein the first valve element is movable with respect to the second valve element; and

a first biasing element acting on the valve, wherein the valve is actuated between an open position and a closed position in response to a pressure difference acting on the valve, the pressure difference comprising a

16

difference between a fluid pressure outside of the downhole tubular and a fluid pressure inside of the downhole tubular, or a difference between a fluid pressure at a first end of the housing and a fluid pressure at a second end of the housing, or both,

wherein the valve is in a closed position when the pressure difference is less than a threshold value and the valve is an open position when the pressure difference is greater than the threshold value,

wherein the first biasing element is preloaded by movement of the first and the second valve elements together in response to an increase in the pressure difference in response to lowering the flow stop valve downhole,

wherein the second valve element comprises a port and a passage, the port being in fluidic communication with the passage such that a flow to the port is selectively blocked by movement of the second valve element or first valve element, or both, wherein when the valve is in the open position a flow path exists from the first end of the housing, through the port and the passage of the second valve element to the second end of the housing, and

wherein the first valve element and the housing at least partially define a first chamber, the first chamber being arranged such that when the valve is closed, the first chamber is not in fluidic communication with the second end of the housing.

13. The flow stop valve of claim 12, further comprising a passage provided through the first valve element, the passage providing a flow path from the first end of the housing to the first chamber.

14. The flow stop valve of claim 12, wherein a projected area of the first valve element facing the fluid in the first end of the housing is greater than a projected area of the first valve element facing the fluid in the first chamber.

15. The flow stop valve of claim 12, further comprising a second chamber formed between the first valve element and the housing, the second chamber being sealed from fluidic communication with the first end of the housing and the first chamber.

16. The flow stop valve of claim 15, further comprising a vent formed through a side wall of the housing, the vent providing a flow path between the second chamber and outside the housing.

17. A flow stop valve positionable in a downhole tubular, the flow stop valve comprising:

a housing;

a valve selectively permitting fluid flow through the flow stop valve, the valve comprising a first valve element and a second valve element movably located within the housing, wherein the first valve element is movable with respect to the second valve element; and

a first biasing element acting on the valve, wherein the valve is actuated between an open position and a closed position in response to a pressure difference acting on the valve, the pressure difference comprising a difference between a fluid pressure outside of the downhole tubular and a fluid pressure inside of the downhole tubular, or a difference between a fluid pressure at a first end of the housing and a fluid pressure at a second end of the housing, or both,

wherein the valve is in a closed position when the pressure difference is less than a threshold value and the valve is an open position when the pressure difference is greater than the threshold value,

wherein the first biasing element is preloaded by movement of the first and the second valve elements together

17

18

in response to an increase in the pressure difference in response to lowering the flow stop valve downhole, wherein the first valve element and the housing at least partially define a first chamber, the first chamber being arranged such that when the valve is closed, the first chamber is not in fluidic communication with the second end of the housing, and wherein the flow stop valve further comprising a second chamber formed between the first valve element and the housing, the second chamber being sealed from fluidic communication with the first end of the housing and the first chamber.

18. The flow stop valve of claim 17, further comprising a vent formed through a side wall of the housing, the vent providing a flow path between the second chamber and outside the housing.

* * * * *