

No. 889,217.

PATENTED JUNE 2, 1908.

W. E. FINCH.
POISE LOCK FOR SCALES.
APPLICATION FILED APR. 15, 1907.

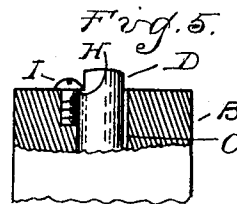
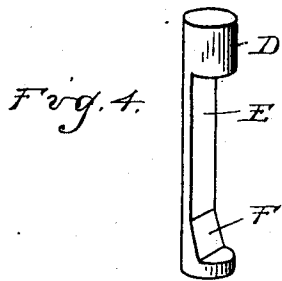
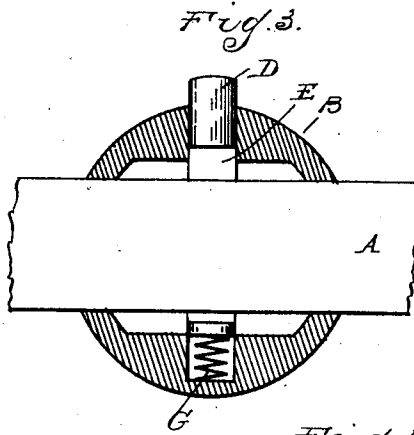
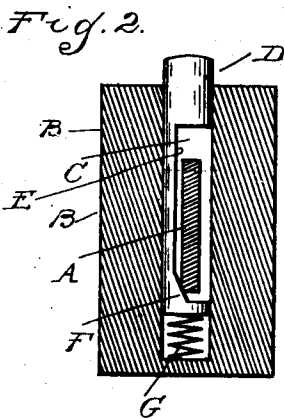
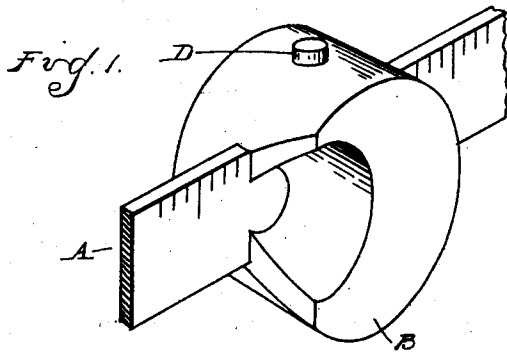

Witnesses
James P. Barry
Chas. O'Donnell

Inventor
W. E. Finch
134 Whittemore Hubert Whittemore
attys.

UNITED STATES PATENT OFFICE.

WILLIS E. FINCH, OF DETROIT, MICHIGAN, ASSIGNOR TO THE W. F. STIMPSON COMPANY, OF DETROIT, MICHIGAN, A CORPORATION OF MICHIGAN.

POISE-LOCK FOR SCALES.

No. 889,217.

Specification of Letters Patent.

Patented June 2, 1908.

Application filed April 15, 1907. Serial No. 368,321.

To all whom it may concern:

Be it known that I, WILLIS E. FINCH, a citizen of the United States of America, residing at Detroit, in the county of Wayne and State of Michigan, have invented certain new and useful Improvements in Poise-Locks for Scales, of which the following is a specification, reference being had therein to the accompanying drawings.

It is the object of the invention to provide a simple and inexpensive locking device for the poise of a scale beam, and to this end the invention consists in the construction as hereinafter set forth.

In the drawings, Figure 1 is a perspective view of the poise in engagement with the beam; Fig. 2 is a transverse section thereof; Fig. 3 is a longitudinal section; Fig. 4 is a perspective view of the locking member detached; and Fig. 5 is a section similar to Fig. 2, illustrating a modification.

A is the scale beam, of any suitable construction, and B is the poise sleeved thereon, so as to be freely slidable. To attach my improved locking device, the poise B is bored, preferably vertically to intersect the transverse slot through which the beam A passes. In this bore C is placed the locking member D, which may be formed of a rod or pin, cut away at E to provide clearance for the beam, and having an inclined or wedge portion F. The latter is so arranged that when the pin is moved in one direction in the recess C, the wedge will bind against the beam and frictionally lock the poise.

G is a spring, which is dropped down into the lower end of the recess C, and bears against the lower end of the pin, forcing the same upward. The upper end of the pin projects out from the recess C and forms a push button for depressing the pin and disengaging the wedge from the beam.

With the construction as described, it will be understood that the poise is self-locking, and will be held from displacement at every point to which it may be adjusted. At the same time, the operator may freely slide the poise by placing his thumb upon the upper end of the rod D and depressing it sufficiently to disengage the wedge.

If it is desired to hold the pin from locking, this may be accomplished by the modified construction illustrated in Fig. 5, in which a shoulder H is formed in the upper portion of the pin for engaging a detent, such as the

screw I in the poise B. The pin D is formed with sufficient clearance in the bore, or recess C, so that it may be moved laterally into or out of engagement with the detent, and thus the operator can at will either lock the poise or lock the pin to permit the poise to freely slide.

What I claim as my invention is:

1. The combination with a scale beam and a poise slidably engaging the same, said poise having a recess intersecting the path of the beam therethrough, of a member placed in said recess, having a wedge portion formed thereon and automatic means for engaging said wedge portion with the beam to lock said poise thereon.

2. The combination with a scale beam and a poise slidable thereon, said poise having a recess of a member placed in said recess in said poise which intersects the path of said beam, a wedge portion on said member for engaging said beam, and a resilient member for forcing said wedge into engagement.

3. The combination with a scale beam, of a poise slidable thereon having a recess intersecting the path of said beam, a member placed in said recess having a wedge portion for engaging said beam, and an operating portion projecting out from said recess and resilient means for forcing said member outward and said wedge into engagement with the beam.

4. The combination with a scale beam, of a poise slotted to slidably engage said beam and having a transversely extending recess intersecting said slot, a pin placed in said recess having a portion thereof cut away to clear said beam, and provided with a wedge portion for engaging said beam.

5. The combination with a scale beam, of a poise slotted to slidably engage said beam and having a transversely extending recess intersecting said slot, a pin placed in said recess having a portion thereof cut away to provide clearance for said beam and also provided with a wedge portion for engaging said beam and a spring in said recess for yieldably pressing said pin to engage the wedge with said beam.

6. The combination with a scale beam, of a poise transversely slotted to slidably engage said beam and having a vertical recess intersecting said transverse slot, a spring in the lower portion of said recess, a pin in said recess bearing against said spring, said pin

being cut away to provide clearance for said
beam and having a wedge portion at its
lower end for engaging said beam when said
pin is pressed upward by said spring, the
5 upper end of said pin projecting outward
and forming a push button for disengaging
the wedge.

7. The combination with a scale beam, of
a poise slotted to engage said beam and hav-
10 ing a transversely extending recess intersect-
ing said slot, a pin slidable in said recess and
having a wedge portion for engaging said

beam, a spring for yieldably pressing said
wedge into engagement with said beam and
a detent for engaging said pin to lock the 15
same from movement under the tension of
said spring.

In testimony whereof I affix my signature
in presence of two witnesses.

WILLIS E. FINCH.

Witnesses:

JAMES P. BARRY,
NELLIE KINSELLA.