

May 23, 1961

J. TITLE

2,985,170

SANITARY GARMENT

Filed Sept. 6, 1957

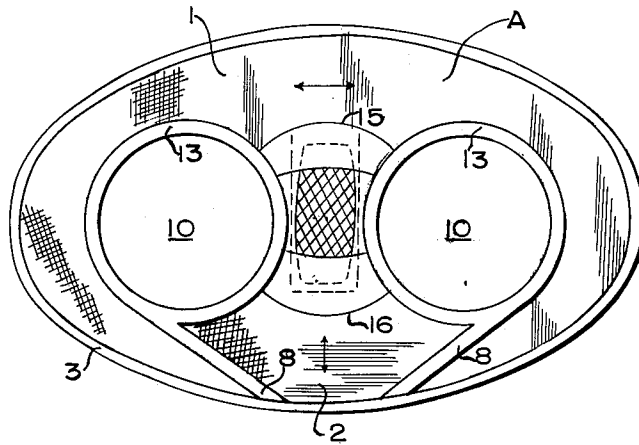

FIG. 1.

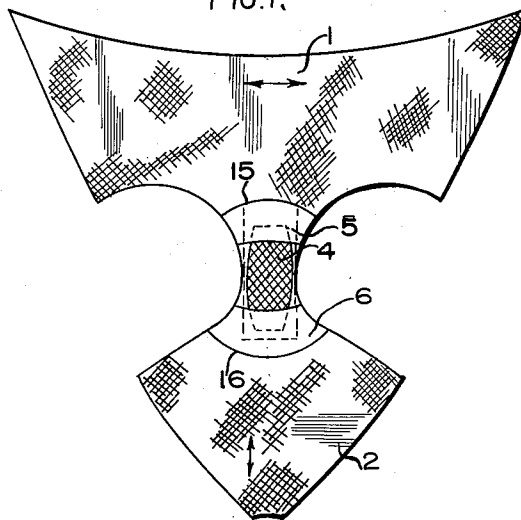

FIG. 2.

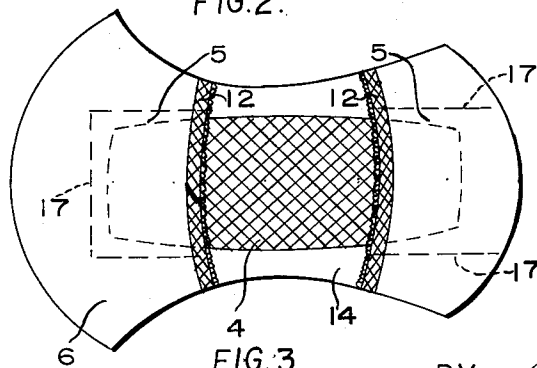

FIG. 3.

Inventor
JACK TITLE
BY *Smoot & Biggs*
ATTORNEY

1

2,985,170

SANITARY GARMENT

Jack Title, 3575 St. Lawrence Blvd., Montreal,
Quebec, Canada

Filed Sept. 6, 1957, Ser. No. 682,552

3 Claims. (Cl. 128—284)

This invention relates to a female undergarment of the panty type which includes means for retaining a sanitary pad therein.

Undergarments which are adapted for the insertion of a sanitary pad are known. However, such garments have the disadvantage that when the wearer is moving or walking the pad tends to move about due to the inability of the garment to adapt itself to the movements of the wearer.

The present invention is intended to overcome the above disadvantage. The garment according to the invention comprises a front section stretchable primarily in a horizontal direction but substantially less stretchable vertically, a rear section stretchable primarily vertically but substantially less stretchable horizontally, and a gusset member which holds the sanitary pad. It is preferable to use a pair of pockets with their openings opposite each other for the purpose of holding the pad, the openings being spaced apart about 4 inches and so positioned that with the ends of the pad tucked into them, the exposed portion of the pad would be opposite the vaginal orifice of a wearer. It is also preferable that the seams connecting the front and rear sections extend from the top centre back of the garment downwardly at an angle of approximately 45°. The above arrangement results in a greatly reduced movement of the sanitary pad, relative to the body compared with known garments of this general type, since expansion of the rear of the body in the vertical direction, and of the front of the body in the horizontal direction while the wearer is, for example, sitting down, results in similar expansion of the front and rear portions of the garment, and not, as with known garments, in shifting of the positions of the various portions of the garment and of the sanitary pad past the wearer's body. In addition to the above advantages I have produced a garment which is simple to manufacture and easy to keep clean.

In the drawings, which illustrate an embodiment of the invention:

Figure 1 is an elevation showing the inside of the garment looking at it from the top,

Figure 2 is a view of the front, gusset, and rear sections of the garment, laid out prior to sewing of the side seams, and

Figure 3 is a plan view of the gusset showing the manner in which the sanitary pad is held in position.

In the drawings, the garment is indicated generally at A. The front section 1 of the garment is joined to the rear section 2 by generally diagonal seams 8, which in this embodiment extend from the top centre back of the garment down at an angle of approximately 45° to the sides of the garment. This is desirable because those parts of the body which tend to expand in a horizontal direction while the wearer is bending down or sitting, i.e., the lower abdomen and the upper portion of the hips, are by this arrangement covered by the front section 1, and that part of the body which expands vertically

2

the most while the wearer is bending or sitting, i.e., the posterior, is covered by the rear section. The front and rear sections are made from a suitable material which will stretch in one direction but is substantially less stretchable in a direction normal to that direction. The back section 2 is cut so that it will stretch in a vertical direction, and is accordingly substantially resistant to stretching in a horizontal direction, and the front section 1 is cut so that it will stretch in a horizontal direction, and accordingly has little resilience in the vertical direction. It is preferred to use a waist encircling member 3 of some elastic material to support the garment. The leg openings 10 are preferably formed with an elastic hem 13 to ensure that they fit snugly about the legs of the wearer.

The gusset section 6 (see Fig. 3), in this embodiment is formed with two pockets 5. These pockets are formed with their openings opposite each other so that a sanitary pad 4 may be conveniently held in them. For the purpose of firmly holding the sanitary pad in position, the edges 12 of the pockets 5 are formed with elastic or other resilient material. The size of the pockets is limited by stitching 17 so that a conventional sanitary pad will fit snugly in them. The pocket openings are preferably spaced about 4" apart, so that only that part of the pad which directly absorbs the menstrual flow is exposed. The pockets may be formed from the same material as the rest of the garment, or may be composed of another material, for example a plastic material. To prevent a heavy vaginal discharge from soiling the material of the panty, a non-porous member 14 is preferably installed beneath the pad. This member may be of plastic or any other suitable flexible material. The gusset section is sewn at 15 to the front section and at 16 to the rear section.

It will be obvious that the gusset may be made of any material, e.g. nylon, cotton mixtures, or material having a rubber content.

Since the sanitary pad is held in place by the pockets, which in turn are simply sewn to the gusset member, there are no protuberances which would cause discomfort to a wearer. Further, it will easily be seen that due to the flexing action of the front and rear sections, movement of the wearer's body will not cause the pad to move about, thereby causing discomfort. The garment is also very simple to make.

It should be understood that suitable modifications may be made in the structure as disclosed, provided such modifications come within the spirit and scope of the appended claims.

What I claim as my invention is:

1. A close fitting female nether garment comprising, in combination, a front section stretchable primarily in a horizontal direction but substantially less stretchable vertically, a rear section stretchable primarily in a vertical direction but substantially less stretchable horizontally, a gusset joining said front and rear sections, said front and back sections and said gusset being joined to form a panty garment having two leg holes and a waist hole, the edges of the garment at said leg holes being formed with extendible leg hole bands, said gusset being provided with means adapted to hold a sanitary pad adjacent to the vaginal orifice of a wearer, said means comprising a pair of pockets having their openings facing each other, the edges of said pockets being formed of a resilient material extending substantially to both side edges of said gusset to thereby exert an extending action forcing the pad against the gusset to hold said pad in place when the leg hole bands are extended in wearing the garment.

2. A close fitting female nether garment comprising, in combination, a front section stretchable primarily in a

3

horizontal direction but substantially less stretchable vertically, a rear section stretchable primarily in a vertical direction but substantially less stretchable horizontally, said front and rear sections being connected by generally diagonal seams which are adjacent one another in the region of the top centre rear of the garment and spaced maximally at the base thereof, a gusset joining said front and rear sections, said front and back sections and said gusset being joined to form a panty garment having two leg holes and a waist hole, the edges of the garment at said leg holes being formed with extendible leg hole bands, said gusset being provided with means adapted to hold a sanitary pad adjacent to the vaginal orifice of a wearer, said means comprising a pair of pockets having their openings facing each other, the edges of said pockets being formed of a resilient material extending substantially to both side edges of said gusset to thereby exert an extending action forcing the pad against the gusset to hold said pad in place when the leg hole bands are extended in wearing the garment.

3. A close fitting nether garment comprising, in combination, a front section stretchable primarily in a horizontal direction but substantially less stretchable vertically, a rear section stretchable primarily in a vertical direction but substantially less stretchable horizontally, the seams connecting said front and rear sections being adjacent one another in the region of the top centre rear of

4

the garment, and extending downwardly to the base of the garment at an angle of approximately 45° and being spaced maximally thereat, a gusset joining said front and rear sections, said front and back sections and said gusset being joined to form a panty garment having two leg holes and a waist hole, the edges of the garment at said leg holes being formed with extendible leg hole bands, said gusset being provided with means adapted to hold a sanitary pad adjacent to the vaginal orifice of a wearer, said means comprising a pair of pockets having their openings facing each other, the edges of said pockets being formed of a resilient material extending substantially to both side edges of said gusset to exert an extending action forcing the pad against the gusset to hold said pad in place when the leg hole bands are extended in wearing the garment.

References Cited in the file of this patent

UNITED STATES PATENTS

20	1,937,899	Coney -----	Dec. 5, 1933
	2,011,027	Ballard et al. -----	Aug. 13, 1935
	2,052,598	Berg -----	Sept. 1, 1936
	2,102,359	Frieman -----	Dec. 14, 1937
	2,465,913	Murdock -----	Mar. 29, 1949
25	2,558,099	Palen -----	June 26, 1951
	2,705,957	Mauro -----	Apr. 12, 1955