



US 20040129581A1

(19) **United States**

(12) **Patent Application Publication**
Tompkins

(10) **Pub. No.: US 2004/0129581 A1**

(43) **Pub. Date: Jul. 8, 2004**

(54) **BARIUM SWALLOWING KIT**

(52) **U.S. Cl. 206/223; 206/570**

(76) **Inventor: Janet Tompkins, Sparta, NC (US)**

(57) **ABSTRACT**

Correspondence Address:

MCNAIR LAW FIRM

P.O. BOX 10827

GREENVILLE, SC 29603-0827 (US)

(21) **Appl. No.: 10/719,779**

(22) **Filed: Nov. 21, 2003**

Related U.S. Application Data

(60) **Provisional application No. 60/428,340, filed on Nov. 22, 2002.**

Publication Classification

(51) **Int. Cl.⁷ B65D 69/00**

A barium swallowing kit comprising a primary container and a plurality of individual food containers included in the primary container. Each of the food containers includes a measured amount of a liquid or a solid food of differing consistency to provide variety for testing the patient's swallowing mechanism. A plurality of barium packets are also included in the primary container. Each of the barium packets has a measured amount of barium sulfate for mixing with the food in one of the food containers. Accordingly, the invention provides for a ready-made dosage of barium sulfate to be mixed with an included solid or liquid food substance to facilitate the determination of whether the patient is experiencing an aspiration problem during swallowing.

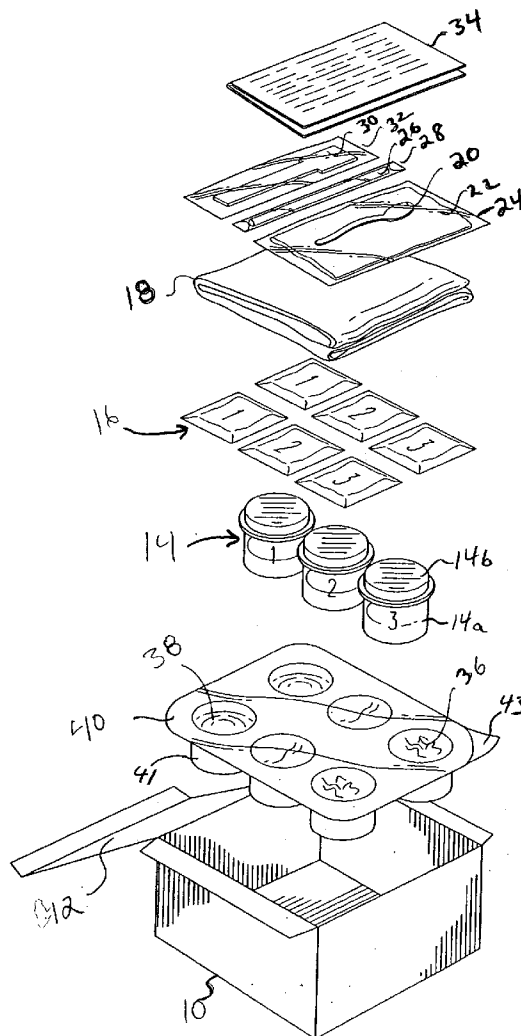

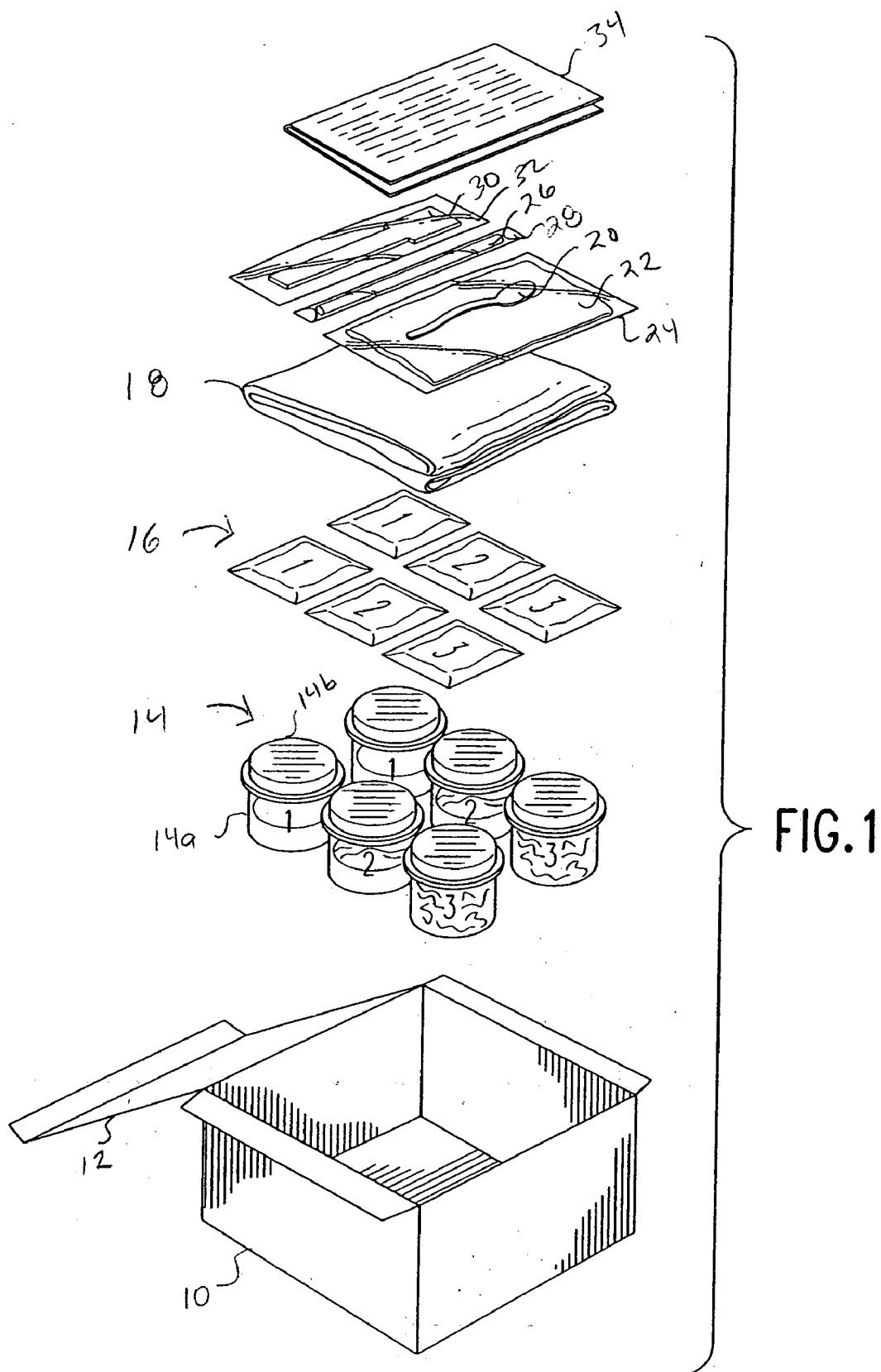

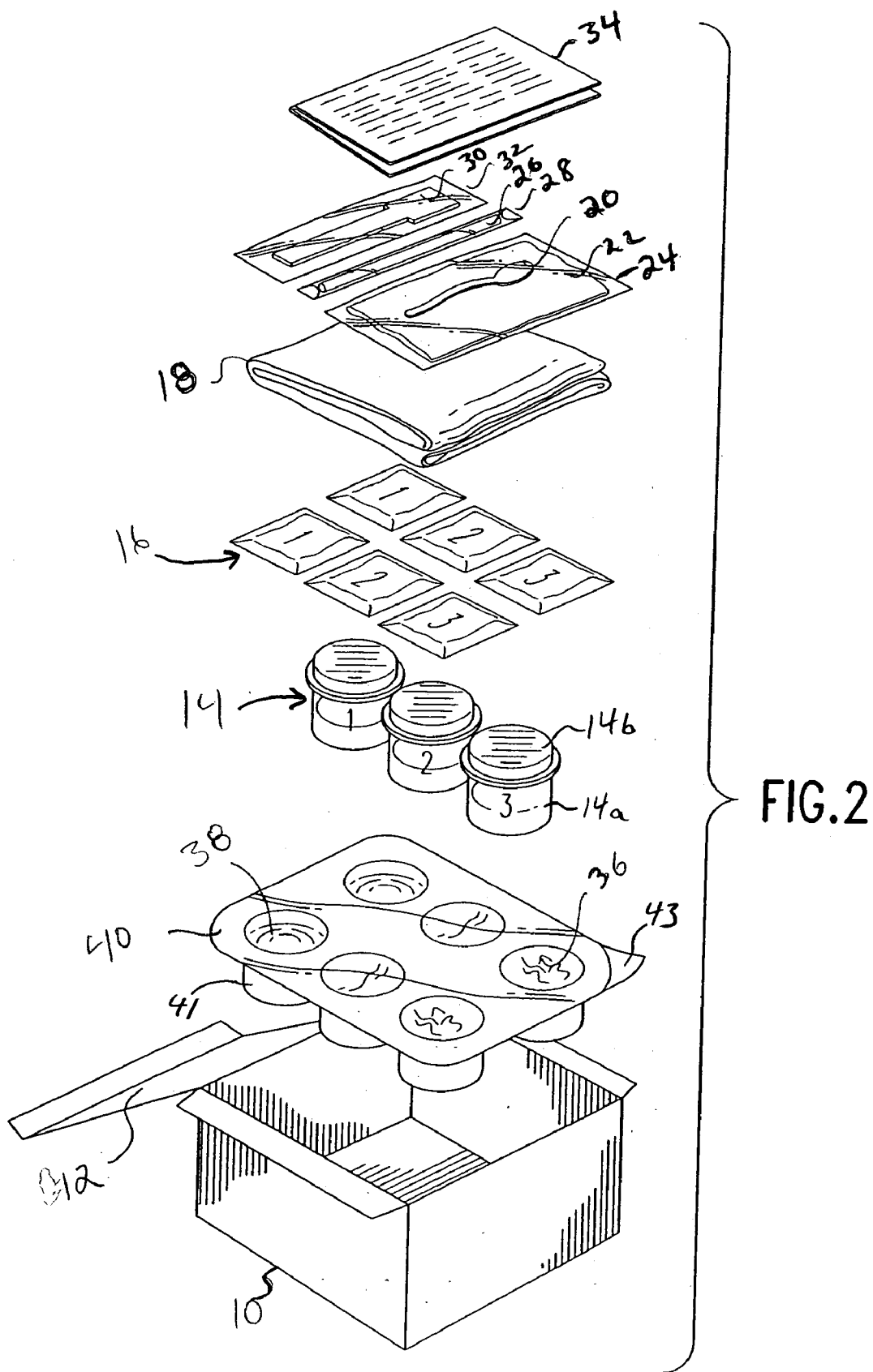

FIG. 2

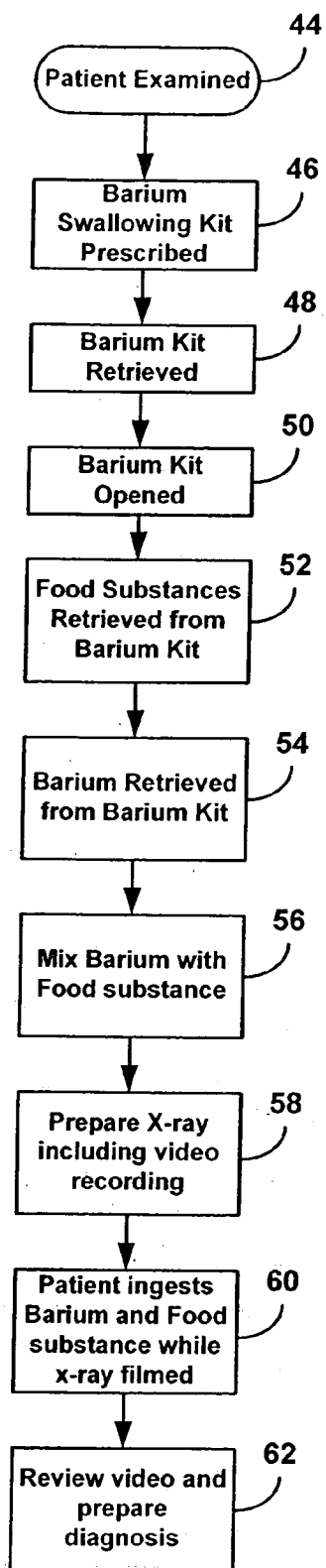

Fig 3

BARIUM SWALLOWING KIT**CROSS REFERENCE TO RELATED APPLICATION**

[0001] Applicant claims priority of U.S. Provisional Patent Application No. 60/428,340 filed Nov. 21, 2002.

FIELD OF THE INVENTION

[0002] The present invention relates to modified barium swallowing studies, and more particularly, to a barium swallowing kit for providing the necessary components for testing the swallowing mechanism of a patient and recording the results by x-ray videotape.

BACKGROUND OF THE INVENTION

[0003] A modified barium swallowing study is a videotaped x-ray of a patient's oral (mouth) and pharyngeal (throat) mechanism during the eating or drinking process. This test can be used to detect dysphagia, a term used to describe a difficulty in swallowing. The process of swallowing is complex and involves twenty-six pairs of muscles and seven cranial nerves. The process generally begins with the sight of food and is completed with the food entering the stomach. In the event that the normal process of swallowing is interfered with, respiratory illness and choking can result. When foods or liquids enter the airway, a patient can aspirate resulting in choking, illness such as pneumonia, and breathing problems.

[0004] In order to determine whether aspiration or other swallowing disorders are present in a patient, the modified barium swallowing study is performed. As this study is an x-ray videotape of the patient's swallowing abilities, it is generally performed in a radiology department. A videotape is made of the patient swallowing a variety of foods and liquids mixed with barium, therefore allowing the food to appear on an x-ray. The use of a modified barium swallowing study can show whether aspiration is occurring in the airway below the level of the vocal cords and determine whether silent aspiration is present. Silent aspiration is defined as a cough that is not produced within ten seconds of an aspiration episode.

[0005] In performing a modified barium swallowing study, various types of food and liquid consistencies are used which have been mixed with barium. Additionally, utensils are necessary such as a fork, spoon, straw, mixing palette, napkin. Presently, when a radiology department wishes to perform a modified barium swallowing study, the radiology department must request the various food substances from the cafeteria. As the cafeteria's primary purpose is to provide food to the entire hospital system, the radiology department may not be able to use the same type of food with the necessary differences in consistency for each barium swallowing test.

[0006] Typically, once the food is ordered from the cafeteria, it is sent to the radiology department where it is then mixed with barium in the form of barium sulfate. The logistics of the present process, based on the delay in ordering the food, receiving the food from the cafeteria, and adding a carefully measured amount of barium sulfate, create unnecessary delays for the patient, the radiology department, and the speech language pathologist. This is in addition to the problem of not receiving the correct foods from the hospital cafeteria.

[0007] To conduct the test, food is received by the radiology department and mixed with barium, thereby resulting in a barium coated liquid or solid food. Barium inventory is kept in the radiology department and it is up to the speech language pathologist, or possibly the radiology technician, to prepare the appropriate mixture of food substance and barium. Therefore, providing a barium swallowing kit where all the necessary elements are contained in a single location, prepackaged for use by the patient, speech language pathologist, and the radiology department is a problem to which the present invention is directed

[0008] Accordingly, it is an object of the present invention to provide a complete kit containing all the materials needed to prepare food samples for a modified barium swallowing study.

[0009] Another object of this invention is to provide a barium swallowing kit containing a measured amount of solid food and liquid food of differing consistencies, and a measured amount of barium sulfate for mixing with the food for use during a modified barium swallowing study in order to provide more consistent results in a timely manner.

SUMMARY OF THE INVENTION

[0010] The above objectives are accomplished by providing a barium swallowing kit for use in x-ray procedures to study a patient's swallowing mechanism. The kit first includes a primary container for housing the kit items. A plurality of individual food containers are then included in the primary container. Each of the food containers includes a measured amount of a liquid or a solid food of differing consistency to provide variety for testing the patient's swallowing mechanism. A plurality of barium packets are also included in the primary container. Each of the barium packets has a measured amount of barium sulfate for mixing with the food in one of the food containers.

[0011] Preferably, each of the food containers in the barium swallowing kit is adapted for carrying approximately 4 ounces of solid food and approximately 6 ounces of liquid food. Further, each of the food containers preferably includes a food reservoir portion and a removable lid enclosing the food reservoir portion so that the food is enclosed in the food reservoir portion until mixing with the barium sulfate, which is done in the food reservoir portion without the need for a separate mixing container.

[0012] In a preferred embodiment, each barium packet contains an amount of barium sulfate to mix with the food at a ratio of between 20-60% barium sulfate by volume. Additionally, in a particularly advantageous embodiment, each barium packet contains barium sulfate in a powder form for mixing with the food in the food containers.

[0013] The barium swallowing kit also includes a napkin contained within the primary container for use by the patient upon ingestion of the food. A spoon is also contained within the primary container for eating the solid or liquid food. A spatula is also contained within the primary container for mixing the food with the barium sulfate. A straw is also contained within the primary container for drinking the liquid food. A set of instructions is also contained within the primary container for explaining use of the kit items.

[0014] Preferably, at least two of the food containers include liquid foods of differing consistency, and at least two of the food containers include solid foods of differing consistency.

DESCRIPTION OF THE DRAWINGS

[0015] The invention will be more readily understood from a reading of the following specifications and by reference to the accompanying drawings forming a part thereof, wherein an example of the invention is shown and wherein:

[0016] **FIG. 1** is a perspective of the elements of the invention,

[0017] **FIG. 2** is a perspective of an alternative embodiment of the elements of the invention,

[0018] **FIG. 3** is a flowchart illustrating the method of using the invention.

DETAILED DESCRIPTION OF A PREFERRED EMBODIMENT

[0019] Referring now to **FIG. 1**, the kit includes a primary container **10** shown having top **12** for enclosing the primary container. A plurality of individual food containers, designated generally as **14**, are provided for placement within primary container **10**. Each of the food containers includes a measured amount of a liquid or a solid food of differing consistency to provide variety for testing the patient's swallowing mechanism. Food substances can include, for example, fruits, meats, crackers, cookies, pudding, and juices. It is desirable to have differing consistencies of foods from solids to liquids to facilitate the various levels of aspiration that may occur in patients who have swallowing problems. For example, a patient may be able to swallow pudding without difficulty, but will be unable to swallow juice without difficulty. Preferably, at least two of food containers **14** include liquid foods of differing consistency, and at least two of the food containers include solid foods of differing consistency.

[0020] Preferably, each individual food container **14** is of a sufficient volume to carry approximately 4 ounces of solid food and approximately 6 ounces of liquid food, which is usually sufficient to conduct the modified barium study of the specific food being swallowed. Further, each of the food containers preferably includes a food reservoir portion **14a** and a removable lid **14b** enclosing the food reservoir portion so that the food is enclosed in the food reservoir portion until mixing with the barium sulfate, which is done in the food reservoir portion without the need for a separate mixing container.

[0021] A plurality of barium packets, designated generally as **16**, are included in primary container **10**, which contain a predetermined measured amount of barium sulfate (BaSO_4) to be mixed with the solid food or liquid food substance of food containers **14**. Preferably, the barium packets contain at least one ounce of barium sulfate in a powder form for mixing with the solid or liquid foods. Alternatively, the barium sulfate could be suspended in a liquid, or even a paste, but powder is the preferred option for mixing with foods of various consistency. Generally, the amount of barium mixed with the solid or liquid food is done in a ratio of between 20-60% barium sulfate by volume. In a preferred embodiment, the barium sulfate is mixed with the food at a ratio of 40% barium sulfate by volume. By way of example, in this embodiment, as the food containers are intended to hold approximately 4 ounces of solid food, each

barium packet for mixing with the solid food would hold approximately 1.6 ounces of barium sulfate in a powder form.

[0022] In a preferred embodiment as shown in **FIG. 1**, a napkin **18** is included within primary container **10** so that the napkin is available for use while the patient is ingesting the contents of food containers **14** that have been mixed with barium sulfate. A spoon **20** is also contained within primary container **10** for eating the solid and liquid foods. In a further advantageous embodiment, spoon **20** is included with a sanitary napkin **22** in a first sterile sealed package **24** so that a sterile spoon and napkin is provided for the patient for use with ingesting the contents of food containers **14**. Further, a mixing spatula **30** is also preferably provided in primary container **10** for mixing the powdery barium sulfate with the selected food. Advantageously, spatula **30** may be enclosed in a second sterile sealed package **32**. Additionally, a straw **26** is included within primary container **10** to assist with ingesting liquids from food containers **14**. Straw **26** helps to deliver foods farther back into the mouth and throat for harder to swallow foods for the particular patient, which promotes operation of the swallowing mechanisms for the test. Straw **26** is preferably wrapped in a third sterile sealed package **28**. Also, a set of instructions **34** is preferably included with the contents of primary container **10** to provide the practitioner the ability to review information concerning the modified barium swallowing kit and its use. Additionally, instructions can be printed on the inside or outside of primary container **10**.

[0023] Referring to **FIG. 2**, solid foods **36** and liquid foods **38** can also be contained within a tray **40** that is carried within primary container **10**. By way of example as shown in **FIG. 2**, tray **40** has a plurality of food reservoirs **41** included within the tray for containing liquid and solid foods. Preferably, each of food reservoirs **41** includes a measured amount of a liquid or a solid food of differing consistency to provide variety for testing the patient's swallowing mechanism. A removable cover **43** is carried by tray **40** for enclosing each of food reservoirs **41** until needed for mixing with the barium sulfate in packets **16** so that the food is prevented from leaking out of the food reservoirs. In the event that tray **40** contains only solid food substances, liquids can be contained in food containers **14** as described above with removable lids, which can also be included within primary container **10** together with tray **40**.

[0024] Referring now to **FIG. 3**, the process for using the enclosed invention is described in more detail. In step **44** the patient is examined. In step **46**, determination is made that a barium swallowing kit needs to be prescribed for the patient. In step **48**, the patient is sent to the radiology department and the barium kit is retrieved from an inventory. In step **50**, the barium kit is opened and prepared for use. In step **52**, food substances are retrieved from the barium kit and opened. In step **54**, barium sulfate is retrieved from the barium kit and opened. In step **56**, the barium sulfate is mixed with the solid or liquid food substance using the spoon, spatula, or some other mixing means. In the event that the barium sulfate is to be put into the liquid, the barium is poured into the liquid and stirred. In step **58**, the x-ray machine is prepared which can include a video recording device so as to record the results of the barium sulfate food mixture being swallowed. In step **60**, the patient ingests the barium sulfate infused substances which can be viewed by

the x-ray machine. In step 62, the results of the x-ray, as well as any video that is created, are reviewed and a diagnosis is prepared for the patient.

What is claimed is:

1. A barium swallowing kit for use in x-ray procedures to study a patient's swallowing mechanism, said kit comprising:

- a primary container for housing the kit items;
- a plurality of individual food containers included in said primary container;
- each of said food containers including a measured amount of a liquid or a solid food of differing consistency to provide variety for testing the patient's swallowing mechanism;
- a plurality of barium packets included in said primary container; and,
- each of said barium packets having a measured amount of barium sulfate for mixing with the food in one of said food containers.

2. The barium swallowing kit of claim 1 wherein each of said food containers. is adapted for carrying approximately 4 ounces of solid food and approximately 6 ounces of liquid food..

3. The barium swallowing kit of claim 1 wherein each of said food containers includes a food reservoir portion and a removable lid enclosing said food reservoir portion so that the food is enclosed in said food reservoir portion until mixing with said barium sulfate in said food reservoir portion.

4. The barium swallowing kit of claim 1 Wherein each barium packet contains an amount of barium sulfate to mix with the food at a ratio of between 20-60% barium sulfate by volume.

5. The barium swallowing kit of claim 1 wherein each barium packet contains barium sulfate in a powder form for mixing with said food in said food containers.

6. The barium swallowing kit of claim 1 including a napkin contained within said primary container for use by said patient upon ingestion of said food.

7. The barium swallowing kit of claim 1 including a spoon contained within said primary container for eating said solid or liquid food.

8. The barium swallowing kit of claim 1 including a spatula contained within said primary container for mixing said food with said barium sulfate.

9. The barium swallowing kit of claim 1 including a straw contained within said primary container for drinking said liquid food.

10. The barium swallowing kit of claim 1 including a set of instructions contained within said primary container for explaining use of the kit items.

11. The barium swallowing kit of claim 1 wherein at least two of said food containers include liquid foods of differing consistency, and wherein at least two of said food containers include solid foods of differing consistency.

12. A barium swallowing kit for use in x-ray procedures to study a patient's swallowing mechanism, said kit comprising:

- a primary container for housing the kit items;
- a tray having a plurality of individual food reservoirs included in said primary container;
- each of said food reservoirs including a measured amount of a liquid or a solid food of differing consistency to provide variety for testing the patient's swallowing mechanism;
- a removable cover carried by said tray enclosing each of said food reservoirs until needed to prevent the food from leaking out of said food reservoirs;
- a plurality of barium packets included in said primary container; and,
- each of said barium packets having a measured amount of barium sulfate for mixing with the food in one of said food reservoirs.

13. The barium swallowing kit of claim 12 wherein each barium packet contains an amount of barium sulfate to mix with the food at a ratio of between 20-60% barium sulfate by volume.

14. The barium swallowing kit of claim 12 including a first sterile sealed package that includes a spoon and napkin, which is contained within said primary container for use by said patient upon ingestion of said food.

15. The barium swallowing kit of claim 14 including a second sterile sealed package that includes a spatula, which is contained within said primary container for mixing said food in said individual food reservoirs with said barium sulfate.

16. The barium swallowing kit of claim 15 including a third sterile sealed package that includes a straw, which is contained within said primary container for drinking said liquid food.

17. The barium swallowing kit of claim 12 including a set of instructions printed on said primary container for explaining use of the kit items.

18. A barium swallowing kit for use in x-ray procedures to study a patient's swallowing mechanism, said kit comprising:

- a primary container for housing the kit items;
- a tray having a plurality of individual. food reservoirs included in said primary container;
- each of said food reservoirs including a measured amount of a solid food of differing consistency to provide variety for testing the patient's swallowing mechanism;
- a removable cover carried by said tray enclosing each of said food reservoirs until needed to prevent said solid food from leaking out of said food reservoirs;
- a plurality of liquid food containers included in said primary container;
- each of said liquid food containers including a measured amount of a liquid food of differing consistency to provide variety for testing the patient's swallowing mechanism;
- a removable lid carried by each of said liquid food containers enclosing the container until needed to prevent said liquid food from leaking out of said liquid food containers;

a plurality of barium packets included in said primary container; and,

each of said barium packets having a measured amount of barium sulfate for mixing with the solid or liquid food in one of said food reservoirs and liquid food containers.

19. The barium swallowing kit of claim 18 wherein each barium packet contains an amount of barium sulfate to mix with said solid and liquid food at a ratio of between 20-60% barium sulfate by volume.

20. The barium swallowing kit of claim 18 including a first sterile sealed package that includes a spoon and napkin, a second sterile sealed package that includes a spatula, a third sterile sealed package that includes a straw, and a set of instructions, which are all included in said primary container for use by said patient to mix said solid and liquid food with said barium sulfate and ingest said food.

* * * * *