

(19) AUSTRALIAN PATENT OFFICE

(54) Title
Drug delivery device

(51) ⁶ International Patent Classification(s)
A61F 009/00 A61K 009/00

(21) Application No: 2004200908

(22) Application Date: 2004.03.02

(43) Publication Date : 2004.04.01

(43) Publication Journal Date : 2004.04.01

(62) Divisional of:
768400

(71) Applicant(s)
Alcon, Inc.

(72) Inventor(s)
Yaacobi, Yoseph7

(74) Agent/Attorney
Phillips Ormonde & Fitzpatrick, 367 Collins Street, Melbourne,
VIC, 3000

Abstract

The invention relates to an ophthalmic drug delivery device, comprising:
a body having a scleral surface for placement proximate a sclera and a well having an opening to said scleral surface; and an inner core disposed in said well comprising a pharmaceutically active agent, wherein said pharmaceutically active agent comprises an anti-infective, a steroidal anti-inflammatory agent, a non-steroidal anti-inflammatory agent, an anti-infective and an anti-inflammatory agent, an angiogenesis inhibitor, an antimetabolite a neuroprotective drug or an agent for treating macular degeneration, choroidal neovascularization, retinopathies, retinitis, uveitis, macular edema, glaucoma, and a method of delivering a pharmaceutically active agent to the eye, said eye having a sclera, a Tenon's capsule, and a macula, comprising the steps of:
providing a tablet having a pharmaceutically active agent disposed therein; and
disposing said tablet on an outer surface of said sclera and below said Tenon's capsule.

DRUG DELIVERY DEVICE

Field of the Invention

The present invention generally pertains to biocompatible implants for localized delivery of pharmaceutically active agents to body tissue. More particularly, but not by way of limitation, the present invention pertains to biocompatible implants for localized
5 delivery of pharmaceutically active agents to the posterior segment of the eye.

Description of the Related Art

Several diseases and conditions of the posterior segment of the eye threaten vision. Age related macular degeneration (ARMD), choroidal neovascularization (CNV), retinopathies (i.e. diabetic retinopathy, vitreoretinopathy), retinitis (i.e. cytomegalovirus
10 (CMV) retinitis), uveitis, macular edema, and glaucoma are several examples.

Age related macular degeneration (ARMD) is the leading cause of blindness in the elderly. ARMD attacks the center of vision and blurs it, making reading, driving, and other detailed tasks difficult or impossible. About 200,000 new cases of ARMD occur each year in the United States alone. Current estimates reveal that approximately forty
15 percent of the population over age 75, and approximately twenty percent of the population over age 60, suffer from some degree of macular degeneration. "Wet" ARMD is the type of ARMD that most often causes blindness. In wet ARMD, newly formed choroidal blood vessels (choroidal neovascularization (CNV)) leak fluid and cause progressive damage to the retina.

20 In the particular case of CNV in ARMD, two main methods of treatment are currently being developed, (a) photocoagulation and (b) the use of angiogenesis inhibitors.

However, photocoagulation can be harmful to the retina and is impractical when the CNV is near the fovea. Furthermore, photocoagulation often results in recurrent CNV over time. Oral or parenteral (non-ocular) administration of anti-angiogenic compounds is also being tested as a systemic treatment for ARMD. However, due to drug-specific metabolic restrictions, systemic administration usually provides sub-therapeutic drug levels to the eye. Therefore, to achieve effective intraocular drug concentrations, either an unacceptably high dose or repetitive conventional doses are required. Periocular injections of these compounds often result in the drug being quickly washed out and depleted from the eye, via periocular vasculature and soft tissue, into the general circulation. Repetitive intraocular injections may result in severe, often blinding, complications such as retinal detachment and endophthalmitis.

Therefore, a need exists in the biocompatible implant field for a surgically implantable drug delivery device capable of safe, effective, rate-controlled, localized delivery of a wide variety of pharmaceutically active agents to any body tissue. The surgical procedure for implanting such a device should be safe, simple, quick and capable of being performed in an outpatient setting. Ideally, such a device should be easy and economical to manufacture. Furthermore, because of its versatility and capability to deliver a wide variety of pharmaceutically active agents, such an implant should be capable of use in clinical studies to deliver various agents that create a specific physical condition in a patient or animal subject. In the particular field of ophthalmic drug delivery, such an implantable drug delivery device is especially needed for localized delivery of pharmaceutically active agents to the posterior segment of the eye to combat ARMD, CNV, retinopathies, retinitis, uveitis, macular edema, and glaucoma.

The above discussion of background art is included to explain the context of the present invention. It is not to be taken as an admission that any of the documents or other material referred to was published, known or part of the common general knowledge in Australia at the priority date of any one of the claims of this specification.

SUMMARY OF THE INVENTION

According to one aspect, the present invention provides an ophthalmic drug delivery device, comprising:
a body having a scleral surface for placement proximate a sclera and a well having an opening to said scleral surface; and
an inner core disposed in said well comprising a pharmaceutically active agent, wherein

said pharmaceutically active agent comprises an anti-infective.

According to another aspect the present invention provides an ophthalmic drug delivery device, comprising:

- 5 a body having a scleral surface for placement proximate a sclera and a well having an opening to said scleral surface; and
an inner core disposed in said well comprising a pharmaceutically active agent, wherein said pharmaceutically active agent comprises a steroidal anti-inflammatory agent.

According to a further aspect, the present invention provided an ophthalmic drug delivery device, comprising:

- 10 a body having a scleral surface for placement proximate a sclera and a well having an opening to said scleral surface; and
an inner core disposed in said well comprising a pharmaceutically active agent, wherein said pharmaceutically active agent comprises a non-steroidal anti-inflammatory agent.

According to still another aspect, the present invention provides an ophthalmic drug delivery device, comprising:

- 15 a body having a scleral surface for placement proximate a sclera and a well having an opening to said scleral surface; and
an inner core disposed in said well comprising a pharmaceutically active agent wherein said pharmaceutically active agent comprises an anti-infective and an anti-inflammatory agent.
20

According to yet another aspect, the present invention provides an ophthalmic drug delivery device, comprising:

- a body having a scleral surface for placement proximate a sclera and a well having an opening to said scleral surface; and
25 an inner core disposed in said well comprising a pharmaceutically active agent wherein said pharmaceutically active agent is for the treatment of macular degeneration.

According to yet another aspect, the present invention provides an ophthalmic drug delivery device, comprising:

- a body having a scleral surface for placement proximate a sclera and a well having an opening to said scleral surface; and
30 an inner core disposed in said well comprising a pharmaceutically active agent, wherein said pharmaceutically active agent is for the treatment of choroidal neovascularization.

According to yet another aspect, the present invention provides an ophthalmic drug delivery device, comprising:

a body having a sclera surface for placement proximate a scion and a well having an opening to said scleral surface; and
an inner core disposed in said well comprising a pharmaceutically active agent, wherein said pharmaceutically active agent is for the treatment of retinopathies.

- 5 According to yet another aspect, the present invention provides an ophthalmic drug delivery device, comprising:
a body having a scleral surface for placement proximate a sclera and a well having an opening to said scleral surface; and
an inner core disposed in said well comprising a pharmaceutically active agent, wherein
10 said pharmaceutically active agent is for the treatment of retinitis.

- According to yet another aspect, the present invention provides an ophthalmic drug deliver device, comprising:
a body having a scleral surface for placement proximate a sclera and a well having an opening to said scleral surface; and
15 an inner core in said well comprising a pharmaceutically active agent, wherein said pharmaceutically active agent is for the treatment of uveitis.

- According to yet another aspect, the present invention provides an ophthalmic drug delivery device, comprising:
a body having a scleral surface for placement proximate a sclera and a well having an opening to said scleral surface; and
20 an inner core disposed in said well comprising a pharmaceutically active agent, wherein said pharmaceutically active agent is for the treatment of macular edema.

- According to yet another aspect, the present invention provides an ophthalmic drug delivery device, comprising:
25 a body having a scleral surface for placement proximate a sclera and a well having an opening to said scleral surface; and
an inner core disposed in said well comprising a pharmaceutically active agent, wherein said pharmaceutically active agent is for the treatment of glaucoma.

- According to yet another aspect, the present invention provides an
30 ophthalmic drug delivery device, comprising:
a body having a scleral surface for placement proximate a sclera and a well having an opening to said scleral surface; and
an inner core disposed in said well comprising a pharmaceutically active agent, wherein said pharmaceutically active agent comprises an angiogenesis inhibitor.

According to yet another aspect, the present invention provides an ophthalmic drug delivery device, comprising:
a body having a scleral surface for placement proximate a sclera and a well having an opening to said scleral surface; and
5 an inner core disposed in said well comprising a pharmaceutically active agent, wherein said pharmaceutically active agent comprises an antimetabolite.

According to yet another aspect, the present invention provides an ophthalmic drug delivery device, comprising:
a body having a scleral surface for placement proximate a sclera and a well having an opening to said scleral surface; and
10 an inner core disposed in said well comprising a pharmaceutically active agent, wherein said pharmaceutically active agent comprises a neuroprotective drug.

According to yet another aspect, the present invention provides a method of delivering a pharmaceutically active agent to the eye, said eye having a sclera, a Tenon's capsule, and a macula, comprising the steps of:
15 providing a tablet having a pharmaceutically active agent disposed therein; and disposing said tablet on an outer surface of said sclera and below said Tenon's capsule.

BRIEF DESCRIPTION OF THE DRAWINGS

20 For a more complete understanding of the present invention, reference is made to the following description taken in conjunction with the accompanying drawings in which:

FIG. 1 is a side sectional view of a drug delivery device according to a preferred embodiment of the present invention;

25 FIG. 2 is a side sectional view of a second drug delivery device according to a preferred embodiment of the present invention;

FIG. 3 is a side sectional view schematically illustrating the human eye;

FIG. 4 is detailed cross-sectional view of the eye of FIG. 3 along line 4-4;

30 FIG. 5 is a perspective view of an ophthalmic drug delivery device according to a preferred embodiment of the present invention;

FIG. 6A is a side sectional view of the ophthalmic drug delivery device of FIG. 5;

FIG. 6B is an enlarged cross-sectional view of the ophthalmic drug delivery device of FIG. 6A taken along line 6B-6B; and

FIG. 7 is a graphical illustration of the results of a pharmacokinetic study with New Zealand White rabbits implanted with the ophthalmic drug delivery device of FIGS. 5 through 6B showing the mean concentration of a pharmaceutically active agent at a target site in the retina and choroid of the rabbits as a function of time.

5 Detailed Description of the Preferred Embodiments

The preferred embodiments of the present invention and their advantages are best understood by referring to FIGS. 1 through 7 of the drawings, like numerals being used for like and corresponding parts of the various drawings.

10 FIG. 1 schematically illustrates a drug delivery device 10 according to a preferred embodiment of the present invention. Device 10 may be used in any case where localized delivery of a pharmaceutically active agent to body tissue is required. By way of example, device 10 may be used to treat a medical disorder of the eye, ear, nose, throat, skin, subcutaneous tissue, or bone. Device 10 may be used in humans or animals.

15 Device 10 generally includes a body 12 having an internal surface 14 and an external surface 16. As shown in FIG. 1, body 12 preferably has a generally rectangular three-dimensional geometry with a proximal end 18 and a distal end 20. Body 12 may have any other geometry that has an internal surface 14 for placement proximate a target tissue in the body of a patient. By way of example, body 12 may have a cylindrical, an oval, a square, or other polygonal three-dimensional geometry.

20 Body 12 includes a well or cavity 22 having an opening 24 to internal surface 14. An inner core 26 is preferably disposed in well 22. Inner core 26 is preferably a tablet comprising one or more pharmaceutically active agents. Alternatively, inner core 26 may comprise a conventional hydrogel having one or more pharmaceutically active agents disposed therein. A retaining member 28 is preferably disposed proximate opening 24.

25 Retaining member 28 prevents inner core 26 from falling out of well 22. When inner core

26 is a cylindrical tablet, retaining member 28 is preferably a continuous rim or lip disposed circumferentially around opening 24 having a diameter slightly less than the diameter of tablet 26. Alternatively, retaining member 26 may comprise one or more members that extend from body 12 into opening 24. Although not shown in FIG. 1, inner core 26 may alternatively comprise a suspension, solution, powder, or combination thereof containing one or more pharmaceutically active agents. In this embodiment, internal surface 14 is formed without opening 24, and the suspension, solution, powder, or combination thereof diffuses through the relatively thin portion of internal surface 14 below inner core 26. Still further in the alternative, device 10 may be formed without well 22 or inner core 26, and the pharmaceutically active agent(s) in the form of a suspension, solution, powder, or combination thereof may be dispersed throughout body 12 of device 10. In this embodiment, the pharmaceutically active agent diffuses through body 12 into the target tissue.

The geometry of device 10 maximizes communication between the pharmaceutically active agent of inner core 26 and the tissue underlying internal surface 14. Internal surface 14 preferably physically contacts the target tissue. By way of example, if the target tissue has a generally flat surface, device 10 would be appropriate for the delivery of a pharmaceutically active agent. As another example, if the target tissue has a generally convex surface, a device 10a shown in FIG. 2 having a generally concave internal surface 14a designed to mate with such a target surface may be utilized. Corners 30 of proximal end 18a, and corners 32 of distal end 20a, may be slanted and/or rounded off to facilitate surgical placement of device 10a and to maximize comfort to the patient. Retaining member 28 is preferably designed with a minimum thickness necessary to retain inner core 26 so as to dispose a surface 26a of inner core 26 in close proximity to

the target tissue. Although not shown in FIGS. 1 or 2, inner core 26 may be formed so that surface 26a physically contacts the target tissue.

Alternatively, device 10 or 10a may be disposed in the body of a patient so that internal surface 14 or 14a is disposed proximate the target tissue. In this case, internal surface 14 or 14a physically contacts intermediate tissue disposed between it and the target tissue. The pharmaceutically active agent of inner core 26 communicates with the target tissue through opening 24 and this intermediate tissue.

Referring again to FIG. 1, body 12 preferably comprises a biocompatible, non-bioerodable material. Body 12 more preferably comprises a biocompatible, non-bioerodable polymeric composition. Said polymeric composition may be a homopolymer, a copolymer, straight, branched, cross-linked, or a blend. Examples of polymers suitable for use in said polymeric composition include silicone, polyvinyl alcohol, ethylene vinyl acetate, polylactic acid, nylon, polypropylene, polycarbonate, cellulose, cellulose acetate, polyglycolic acid, polylactic-glycolic acid, cellulose esters, polyethersulfone, acrylics, their derivatives, and combinations thereof. Examples of suitable soft acrylics are more fully disclosed in U.S. Patent No. 5,403,901, which is incorporated herein in its entirety by reference. Said polymeric composition most preferably comprises silicone. Of course, said polymeric composition may also comprise other conventional materials that affect its physical properties, including, but not limited to, porosity, tortuosity, permeability, rigidity, hardness, and smoothness. Exemplary materials affecting certain ones of these physical properties include conventional plasticizers, fillers, and lubricants. Said polymeric composition may comprise other conventional materials that affect its chemical properties, including, but not limited to, toxicity, hydrophobicity, and body 12 - inner core 26 interaction. Body 12 is preferably impermeable to the pharmaceutically active agent of inner core 26. When body 12 is made from a generally elastic polymeric

composition, the diameter of well 22 may be slightly less than the diameter of inner core 26. This frictional fit secures inner core 26 within well 22. In this embodiment, body 12 may be formed without retaining member 28, if desired.

Inner core 26 may comprise any pharmaceutically active agents suitable for localized delivery to a target tissue. Examples of pharmaceutically active agents suitable for inner core 26 are anti-infectives, including, without limitation, antibiotics, antivirals, and antifungals; antiallergenic agents and mast cell stabilizers; steroidal and non-steroidal anti-inflammatory agents; combinations of anti-infective and anti-inflammatory agents; decongestants; anti-glaucoma agents, including, without limitation, adrenergics, β -adrenergic blocking agents, α -adrenergic agonists, parasyathomimetic agents, cholinesterase inhibitors, carbonic anhydrase inhibitors, and prostaglandins; combinations of anti-glaucoma agents; antioxidants; nutritional supplements; drugs for the treatment of cystoid macular edema including, without limitation, non-steroidal anti-inflammatory agents; drugs for the treatment of ARMD, including, without limitation, angiogenesis inhibitors and nutritional supplements; drugs for the treatment of herpetic infections and CMV ocular infections; drugs for the treatment of proliferative vitreoretinopathy including, without limitation, antimetabolites and fibrinolytics; wound modulating agents, including, without limitation, growth factors; antimetabolites; neuroprotective drugs, including, without limitation, eliprodil; and angiostatic steroids for the treatment of diseases or conditions of the posterior segment of the eye, including, without limitation, ARMD, CNV, retinopathies, retinitis, uveitis, macular edema, and glaucoma. Such angiostatic steroids are more fully disclosed in U.S. Patent Nos. 5,679,666 and 5,770,592, which are incorporated herein in their entirety by reference. Preferred ones of such angiostatic steroids include 4,9(11)-Pregnadien-17 α ,21-diol-3,20-dione and 4,9(11)-Pregnadien-17 α ,21-diol-3,20-dione-21-acetate. Inner core 26 may also comprise

conventional non-active excipients to enhance the stability, solubility, penetrability, or other properties of the active agent or the drug core.

If inner core 26 is a tablet, it may further comprise conventional excipients necessary for tableting, such as fillers and lubricants. Such tablets may be produced using conventional tableting methods. The pharmaceutically active agent is preferably distributed evenly throughout the tablet. In addition to conventional tablets, inner core 26 may comprise a special tablet that bioerodes at a controlled rate, releasing the pharmaceutically active agent. By way of example, such bioerosion may occur through hydrolysis or enzymatic cleavage. If inner core 26 is a hydrogel, the hydrogel may bioerode at a controlled rate, releasing the pharmaceutically active agent. Alternatively, the hydrogel may be non-bioerodable but allow diffusion of the pharmaceutically active agent.

Device 10 may be made by conventional polymer processing methods, including, but not limited to, injection molding, extrusion molding, transfer molding, and compression molding. Preferably, device 10 is formed using conventional injection molding techniques. Inner core 26 is preferably disposed in well 22 after the formation of body 12 of device 10. Retaining member 28 is preferably resilient enough to allow inner core 26 to be inserted through opening 24 and then to return to its position as shown in FIG. 1.

Device 10 is preferably surgically placed proximate a target tissue. The surgeon first makes an incision proximate the target tissue. Next, the surgeon performs a blunt dissection to a level at or near the target tissue. Once the target tissue is located, the surgeon uses forceps to hold device 10 with internal surface 14 facing the target tissue and distal end 20 away from the surgeon. The surgeon then introduces device 10 into the dissection tunnel, and positions device 10 with internal surface 14 facing the target tissue.

Once in place, the surgeon may or may not use sutures to fix device 10 to the underlying tissue, depending on the specific tissue. After placement, the surgeon sutures the opening and places a strip of antibiotic ointment on the surgical wound.

The physical shape of body 12, including the geometry of internal surface 14, well 22, opening 24, and retaining member 28, facilitate the unidirectional delivery of a pharmaceutically effective amount of the pharmaceutically active agent from inner core 26 to the target tissue. In particular, the absence of a polymer layer or membrane between inner core 26 and the underlying tissue greatly enhances and simplifies the delivery of an active agent to the target tissue.

Device 10 can be used to deliver a pharmaceutically effective amount of a pharmaceutically active agent to target tissue for many years, depending on the particular physicochemical properties of the pharmaceutically active agent employed. Important physicochemical properties include hydrophobicity, solubility, dissolution rate, diffusion coefficient, and tissue affinity. After inner core 26 no longer contains active agent, a surgeon may easily remove device 10. In addition, the "pre-formed" tunnel facilitates the replacement of an old device 10 with a new device 10.

FIGS. 3 through 6B schematically illustrate an ophthalmic drug delivery device 50 according to a preferred embodiment of the present invention. Device 50 may be used in any case where localized delivery of a pharmaceutically active agent to the eye is required. Device 50 is particularly useful for localized delivery of active agents to the posterior segment of the eye. A preferred use for device 50 is the delivery of pharmaceutically active agents to the retina proximate the macula for treating ARMD, choroidal neovascularization (CNV), retinopathies, retinitis, uveitis, macular edema, and glaucoma. Of course, device 50 may also be utilized for localized delivery of pharmaceutically active agents to body tissue other than the eye, if desired.

Referring first to FIG. 3, a human eye 52 is schematically illustrated. Eye 52 has a cornea 54, a lens 56, a sclera 58, a choroid 60, a retina 62, and an optic nerve 64. An anterior segment 66 of eye 52 generally includes the portions of eye 52 anterior of a line 67. A posterior segment 68 of eye 52 generally includes the portions of eye 52 posterior of line 67. Retina 62 is physically attached to choroid 60 in a circumferential manner proximate pars plana 70. Retina 62 has a macula 72 located slightly lateral to its optic disk. As is well known in the ophthalmic art, macula 72 is comprised primarily of retinal cones and is the region of maximum visual acuity in retina 62. A Tenon's capsule or Tenon's membrane 74 is disposed on sclera 58. A conjunctiva 76 covers a short area of the globe of eye 52 posterior to limbus 77 (the bulbar conjunctiva) and folds up (the upper cul-de-sac) or down (the lower cul-de-sac) to cover the inner areas of upper eyelid 78 and lower eyelid 79, respectively. Conjunctiva 76 is disposed on top of Tenon's capsule 74. As is shown in FIGS. 3 and 4, and as is described in greater detail hereinbelow, device 50 is preferably disposed directly on the outer surface of sclera 58, below Tenon's capsule 74 for treatment of most posterior segment diseases or conditions. In addition, for treatment of ARMD in humans, device 50 is preferably disposed directly on the outer surface of sclera 58, below Tenon's capsule 74, with an inner core of device 50 proximate macula 72.

FIGS. 5, 6A, and 6B schematically illustrate drug delivery device 50 in greater detail. Device 50 generally includes a body 80 having a scleral surface 82 and an orbital surface 84. Scleral surface 82 is preferably designed with a radius of curvature that facilitates direct contact with sclera 58. Orbital surface 84 is preferably designed with a radius of curvature that facilitates implantation under Tenon's capsule 74. Body 80 preferably has a curved, generally rectangular three-dimensional geometry with rounded sides 86 and 88, proximal end 90, and distal end 92. As shown best in the side sectional

view of FIG. 6A, orbital surface 84 preferably has tapered surfaces 94 and 96 proximate proximal end 90 and distal end 92, respectively, that facilitate sub-Tenon implantation of device 50 and enhance the comfort of the patient. Body 80 may alternatively have a geometry similar to that of device 10a shown in FIG. 2. In addition, body 80 may have
5 any other geometry that has a curved scleral surface 82 for contact with sclera 58. By way of example, body 80 may have a generally cylindrical, oval, square, or other polygonal three-dimensional geometry.

Body 80 includes a well or cavity 102 having an opening 104 to scleral surface 82. An inner core 106 is preferably disposed in well 102. Inner core 106 is preferably a tablet
10 comprising one or more pharmaceutically active agents. Alternatively, inner core 106 may comprise a conventional hydrogel having one or more pharmaceutically active agents disposed therein. A retaining member 108 is preferably disposed proximate opening 104. Retaining member 108 prevents inner core 106 from falling out of well 102. When inner
15 core 106 is a cylindrical tablet, retaining member 108 is preferably a continuous rim or lip disposed circumferentially around opening 104 having a diameter slightly less than the diameter of tablet 106. Alternatively, retaining member 108 may comprise one or more members that extend from body 80 into opening 104. Although not shown in FIG. 6A, inner core 106 may alternatively comprise a suspension, solution, powder, or combination thereof containing one or more pharmaceutically active agents. In this embodiment,
20 scleral surface 82 is formed without opening 104, and the suspension, solution, powder, or combination thereof diffuses through the relatively thin portion of scleral surface 82 below inner core 26. Still further in the alternative, device 50 may be formed without well 102 or inner core 106, and the pharmaceutically active agent(s) in the form of a suspension, solution, powder, or combination thereof may be dispersed throughout body

80 of device 50. In this embodiment, the pharmaceutically active agent diffuses through body 80 into the target tissue.

The geometry and dimensions of device 50 maximize communication between the pharmaceutically active agent of inner core 106 and the tissue underlying scleral surface

5 82. Scleral surface 82 preferably physically contacts the outer surface of sclera 58.

Although not shown in FIGS. 6A or 6B, inner core 106 may be formed so that surface 106a physically contacts the outer surface of sclera 58. Alternatively, scleral surface 82 may be disposed proximate the outer surface of sclera 58. By way of example, device 50 may be disposed in the periocular tissues just above the outer surface of sclera 58 or intra-

10 lamellarly within sclera 58.

Body 80 preferably comprises a biocompatible, non-bioerodable material. Body 80 more preferably comprises a biocompatible, non-bioerodable polymeric composition. The polymeric composition comprising body 80, and the polymers suitable for use in the polymeric compositions of body 80, may be any of the compositions and polymers

15 described hereinabove for body 12 of device 10. Body 80 most preferably is made from a polymeric composition comprising silicone. Body 80 is preferably impermeable to the pharmaceutically active agent of inner core 106. When body 80 is made from a generally elastic polymeric composition, the diameter of well 102 may be slightly less than the diameter of inner core 106. This frictional fit secures inner core 106 within well 102. In

20 this embodiment, body 80 may be formed without retaining member 108, if desired.

Inner core 106 may comprise any ophthalmically acceptable pharmaceutically active agents suitable for localized delivery. Exemplary pharmaceutically active agents include the pharmaceutically active agents listed hereinabove for inner core 26 of device

25 stability, solubility, penetrability, or other properties of the active agent.

If inner core 106 is a tablet, it may further comprise conventional excipients necessary for tableting, such as fillers and lubricants. Such tablets may be produced using conventional tableting methods. The pharmaceutically active agent is preferably distributed evenly throughout the tablet. In addition to conventional tablets, inner core 5 106 may comprise a special tablet that bioerodes at a controlled rate, releasing the pharmaceutically active agent. By way of example, such bioerosion may occur through hydrolysis or enzymatic cleavage. If inner core 106 is a hydrogel, the hydrogel may bioerode at a controlled rate, releasing the pharmaceutically active agent. Alternatively, the hydrogel may be non-bioerodable but allow diffusion of the pharmaceutically active 10 agent.

Device 50 may be made by conventional polymer processing methods, including, but not limited to, injection molding, extrusion molding, transfer molding, and compression molding. Preferably, device 50 is formed using conventional injection molding techniques as described hereinabove for device 10.

15 Device 50 is preferably surgically placed directly on the outer surface of sclera 58 below Tenon's capsule 74 using a simple surgical technique that is capable of being performed in an outpatient setting. The surgeon first performs a peritomy in one of the quadrants of eye 52. Preferably, the surgeon performs the peritomy in the infra-temporal quadrant, about 3 mm posterior to limbus 77 of eye 52. Once this incision is made, the 20 surgeon performs a blunt dissection to separate Tenon's capsule 74 from sclera 58, forming an antero-posterior tunnel. Once the tunnel is formed, the surgeon uses forceps to hold device 50 with scleral surface 82 facing sclera 58 and distal end 92 away from the surgeon. The surgeon then introduces device 50 into the tunnel in a generally circular motion to position inner core 106 of device 50 generally above the desired portion of 25 retina 62. The surgeon then closes the peritomy by suturing Tenon's capsule 74 and

conjunctiva 76 to sclera 58. After closing, the surgeon places a strip of antibiotic ointment on the surgical wound. Alternatively, the surgeon may suture proximal end 90 of device 50 to sclera 58 to hold device 50 in the desired location before closure of the tunnel.

5 In the case of ARMD in the human eye, the surgeon utilizes the above-described technique to position inner core 106 of device 50 in one of two preferred locations in the infra-temporal quadrant of eye 52. One preferred location is directly on the outer surface of sclera 58, below Tenon's capsule 74, with inner core 106 positioned proximate to, but not directly above, macula 72. A surgeon may position inner core 106 of device 50 at this
10 location by moving distal end 92 of device 50 below the inferior oblique muscle in a direction generally parallel to the lateral rectus muscle. A second preferred location is directly on the outer surface of sclera 58, below Tenon's capsule 74, with inner core 106 positioned directly above macula 72. A surgeon may position inner core 106 of device 50
15 at this location by moving distal end 92 of device 50 toward macula 72 along a path generally between the lateral and inferior rectus muscles and below the inferior oblique muscle. For ARMD, the pharmaceutically active agent of inner core 106 is preferably one of the angiostatic steroids disclosed in U.S. Patent Nos. 5,679,666 and 5,770,592.

The physical shape of body 80 of device 50, including the geometry of scleral surface 82, well 102, opening 104, and retaining member 108, facilitate the unidirectional
20 delivery of a pharmaceutically effective amount of the pharmaceutically active agent from inner core 106 through sclera 58, choroid 60, and into retina 62. In particular, the absence of a polymer layer or membrane between inner core 106 and sclera 58 greatly enhances and simplifies the delivery of an active agent to retina 62.

It is believed that device 50 can be used to deliver a pharmaceutically effective
25 amount of a pharmaceutically active agent to retina 62 for many years, depending on the

particular physicochemical properties of the pharmaceutically active agent employed. Important physicochemical properties include hydrophobicity, solubility, dissolution rate, diffusion coefficient, and tissue affinity. After inner core 106 no longer contains active agent, a surgeon may easily remove device 50. In addition, the "pre-formed" tunnel facilitates the replacement of an old device 50 with a new device 50.

The following example illustrates effective drug delivery to a rabbit retina using a preferred embodiment and surgical technique of the present invention, but are in no way limiting.

EXAMPLE

A device 50 was surgically implanted on the outer surface of the sclera, below the Tenon's capsule, generally along the inferior border of the lateral rectus muscle of the right eye of twenty (20) New Zealand White rabbits using a procedure similar to that described hereinabove for implantation of device 50 on sclera 58 of eye 52. Device 50 was constructed as shown in FIGS. 5 through 6B, with the following dimensions. Body 80 had a length 110 of about 15 mm, a width 112 of about 7.0 mm, and a maximum thickness 114 of about 1.8 mm. Retaining member 108 had a thickness 116 of about 0.15 mm. Scleral surface 82 had a radius of curvature of about 8.5 mm and an arc length of about 18 mm. Inner core 106 was a cylindrical tablet with a diameter of about 5.0 mm and a thickness of about 1.5 mm. Opening 104 had a diameter of about 3.8 mm. Well 102 had a diameter of about 4.4 mm. The pharmaceutically active agent used in tablet 106 was 4,9(11)-Pregnadien-17 α ,21-diol-3,20-dione, an angiostatic steroid sold by Seraloids, Inc. of Wilton, New Hampshire, and which is more fully disclosed in U.S. Patent Nos. 5,770,592 and 5,679,666. The formulation of tablet 106 consisted of 99.75 weight percent 4,9(11)-Pregnadien-17 α ,21-diol-3,20-dione, and 0.25 weight percent magnesium stearate.

At one week after implantation, 4 rabbits were euthanized and their right eyes were enucleated. The device 50 was removed from the eyes, and the location of tablet 106 was marked on their sclerae. Following the removal of the anterior segment and the vitreous of each eye and inversion of the thus formed eye-cup, a 10 mm diameter circular zone of retinal tissue, concentric with and below the location of tablet 106 on the sclera, was harvested (the "target site"). A 10 mm diameter circular zone of retinal tissue was also harvested from a second site located remote from the target site and on the other side of the optic nerve. In addition, a 10 mm diameter circular zone of retinal tissue was harvested from a third site located between the second site and the target site. Similar 10 mm diameter circular zones of choroidal tissue were also harvested at the target site, second site, and third site. All these tissues were separately homogenized, and the concentration of angiostatic steroid in each of these tissues was determined via an ocular pharmacokinetic study using high performance liquid chromatography and mass spectrometry analysis (LC-MS/MS). This procedure was repeated at 3, 6, 9, and 12 weeks after implantation.

FIG. 7 shows the mean concentration of 4,9(11)-Pregnadien-17 α ,21-diol-3,20-dione in the retina and the choroid at the target site as a function of time. The "error bars" surrounding each data point represent standard deviation. As shown in FIG. 7, device 50 delivered a pharmaceutically effective and generally constant amount of 4,9(11)-Pregnadien-17 α ,21-diol-3,20-dione to the retina and the choroid at the target site for a time period of up to twelve weeks. In contrast, the levels of 4,9(11)-Pregnadien-17 α ,21-diol-3,20-dione in the retina and the choroid at the second and third sites were at or near zero. Therefore, device 50 also delivered a localized dose of angiostatic steroid to the retina and the choroid at the target site.

25

From the above, it may be appreciated that the present invention provides improved devices and methods for safe, effective, rate-controlled, localized delivery of a variety of pharmaceutically active agents to any body tissue. The surgical procedure for implanting such devices is safe, simple, quick, and capable of being performed in an outpatient setting. Such devices are easy and economical to manufacture. Furthermore, because of their capability to deliver a wide variety of pharmaceutically active agents, such devices are useful in clinical studies to deliver various agents that create a specific physical condition in a patient or animal subject. In the particular field of ophthalmic drug delivery, such devices are especially useful for localized delivery of pharmaceutically active agents to the posterior segment of the eye to combat ARMD, CNV, retinopathies, retinitis, uveitis, macular edema, and glaucoma.

It is believed that the operation and construction of the present invention will be apparent from the foregoing description. While the apparatus and methods shown or described above have been characterized as being preferred, various changes and modifications may be made therein without departing from the spirit and scope of the invention as defined in the following claims.

Throughout the description and claims of this specification, the word "comprise" and variations of that word, such as "comprising" and "comprises" are not intended to exclude other additives, steps or integers.

20

CLAIMS

1. An ophthalmic drug delivery device, comprising:
a body having a scleral surface for placement proximate a sclera and a well having an opening to said scleral surface; and
an inner core disposed in said well comprising a pharmaceutically active agent, wherein said pharmaceutically active agent comprises an anti-infective.
2. An ophthalmic drug delivery device, comprising:
a body having a scleral surface for placement proximate a sclera and a well having an opening to said scleral surface; and
an inner core disposed in said well comprising a pharmaceutically active agent, wherein said pharmaceutically active agent comprises a steroidal anti-inflammatory agent.
3. An ophthalmic drug delivery device, comprising:
a body having a scleral surface for placement proximate a sclera and a well having an opening to said scleral surface; and
an inner core disposed in said well comprising a pharmaceutically active agent, wherein said pharmaceutically active agent comprises a non-steroidal anti-inflammatory agent.
4. An ophthalmic drug delivery device, comprising:
a body having a scleral surface for placement proximate a sclera and a well having an opening to said scleral surface; and
an inner core disposed in said well comprising a pharmaceutically active agent wherein said pharmaceutically active agent comprises an anti-infective and an anti-inflammatory agent.
5. An ophthalmic drug delivery device, comprising:
a body having a scleral surface for placement proximate a sclera and a well having an opening to said scleral surface; and
an inner core disposed in said well comprising a pharmaceutically active agent wherein said pharmaceutically active agent is for the treatment of macular degeneration.
6. An ophthalmic drug delivery device, comprising:
a body having a scleral surface for placement proximate a sclera and a well having an opening to

said scleral surface; and
an inner core disposed in said well comprising a pharmaceutically active agent, wherein said pharmaceutically active agent is for the treatment of choroidal neovascularization.

7. An ophthalmic drug delivery device, comprising:
a body having a sclera surface for placement proximate a sclera and a well having an opening to said scleral surface; and
an inner core disposed in said well comprising a pharmaceutically active agent, wherein said pharmaceutically active agent is for the treatment of retinopathies.

8. An ophthalmic drug delivery device, comprising:
a body having a scleral surface for placement proximate a sclera and a well having an opening to said scleral surface; and
an inner core disposed in said well comprising a pharmaceutically active agent, wherein said pharmaceutically active agent is for the treatment of retinitis.

9. An ophthalmic drug delivery device, comprising:
a body having a scleral surface for placement proximate a sclera and a well having an opening to said scleral surface; and
an inner core in said well comprising a pharmaceutically active agent, wherein said pharmaceutically active agent is for the treatment of uveitis.

10. An ophthalmic drug delivery device, comprising:
a body having a scleral surface for placement proximate a sclera and a well having an opening to said scleral surface; and
an inner core disposed in said well comprising a pharmaceutically active agent, wherein said pharmaceutically active agent is for the treatment of macular edema.

11. An ophthalmic drug delivery device, comprising:
a body having a scleral surface for placement proximate a sclera and a well having an opening to said scleral surface; and
an inner core disposed in said well comprising a pharmaceutically active agent, wherein said pharmaceutically active agent is for the treatment of glaucoma.

12. An ophthalmic drug delivery device, comprising:
a body having a scleral surface for placement proximate a sclera and a well having an opening to said scleral surface; and
an inner core disposed in said well comprising a pharmaceutically active agent, wherein said pharmaceutically active agent comprises an angiogenesis inhibitor.
13. An ophthalmic drug delivery device, comprising:
a body having a scleral surface for placement proximate a sclera and a well having an opening to said scleral surface; and
an inner core disposed in said well comprising a pharmaceutically active agent, wherein said pharmaceutically active agent comprises an antimetabolite.
14. An ophthalmic drug delivery device, comprising:
a body having a scleral surface for placement proximate a sclera and a well having an opening to said scleral surface; and
an inner core disposed in said well comprising a pharmaceutically active agent, wherein said pharmaceutically active agent comprises a neuroprotective drug.
15. A method of delivering a pharmaceutically active agent to the eye, said eye having a sclera, a Tenon's capsule, and a macula, comprising the steps of:
providing a tablet having a pharmaceutically active agent disposed therein; and
disposing said tablet on an outer surface of said sclera and below said Tenon's capsule.
16. The method of claim 15 wherein said disposing step comprises disposing said tablet proximate said macula.
17. The method of claim 15 wherein said disposing step comprises disposing said tablet generally above said macula.
18. The method of claim 15 wherein said tablet is formulated to bioerode and release said pharmaceutically active agent at a controlled rate.

19. An ophthalmic drug delivery device, comprising:
a body having a scleral surface for placement proximate a sclera and a well having an opening to said scleral surface; and
an inner core disposed in said well comprising a pharmaceutically active agent, wherein said pharmaceutically active agent comprises an anti-infective, substantially as herein described with reference to at least one of the accompanying drawings.

20. An ophthalmic drug delivery device, comprising:
a body having a scleral surface for placement proximate a sclera and a well having an opening to said scleral surface; and
an inner core disposed in said well comprising a pharmaceutically active agent, wherein said pharmaceutically active agent comprises a steroidal anti-inflammatory agent, substantially as herein described with reference to at least one of the accompanying drawings.

21. An ophthalmic drug delivery device, comprising:
a body having a scleral surface for placement proximate a sclera and a well having an opening to said scleral surface; and
an inner core disposed in said well comprising a pharmaceutically active agent, wherein said pharmaceutically active agent comprises a non-steroidal anti-inflammatory agent, substantially as herein described with reference to at least one of the accompanying drawings.

22. An ophthalmic drug delivery device, comprising:
a body having a scleral surface for placement proximate a sclera and a well having an opening to said scleral surface; and
an inner core disposed in said well comprising a pharmaceutically active agent wherein said pharmaceutically active agent comprises an anti-infective and an anti-inflammatory agent, substantially as herein described with reference to at least one of the accompanying drawings.

23. An ophthalmic drug delivery device, comprising:
a body having a scleral surface for placement proximate a sclera and a well having an opening to

said scleral surface; and
an inner core disposed in said well comprising a pharmaceutically active agent wherein said pharmaceutically active agent is for the treatment of macular degeneration, substantially as herein described with reference to at least one of the accompanying drawings.

24. An ophthalmic drug delivery device, comprising:
a body having a scleral surface for placement proximate a sclera and a well having an opening to said scleral surface; and
an inner core disposed in said well comprising a pharmaceutically active agent, wherein said pharmaceutically active agent is for the treatment of choroidal neovascularization, substantially as herein described with reference to at least one of the accompanying drawings.

25. An ophthalmic drug delivery device, comprising:
a body having a sclera surface for placement proximate a sclera and a well having an opening to said scleral surface; and
an inner core disposed in said well comprising a pharmaceutically active agent, wherein said pharmaceutically active agent is for the treatment of retinopathies, substantially as herein described with reference to at least one of the accompanying drawings.

26. An ophthalmic drug delivery device, comprising:
a body having a scleral surface for placement proximate a sclera and a well having an opening to said scleral surface; and
an inner core disposed in said well comprising a pharmaceutically active agent, wherein said pharmaceutically active agent is for the treatment of retinitis, substantially as herein described with reference to at least one of the accompanying drawings.

27. An ophthalmic drug deliver device, comprising:
a body having a scleral surface for placement proximate a sclera and a well having an opening to said scleral surface; and

an inner core in said well comprising a pharmaceutically active agent, wherein said pharmaceutically active agent is for the treatment of uveitis, substantially as herein described with reference to at least one of the accompanying drawings.

28. An ophthalmic drug delivery device, comprising:
a body having a scleral surface for placement proximate a sclera and a well having an opening to said scleral surface; and
an inner core disposed in said well comprising a pharmaceutically active agent, wherein said pharmaceutically active agent is for the treatment of macular edema, substantially as herein described with reference to at least one of the accompanying drawings.

29. An ophthalmic drug delivery device, comprising:
a body having a scleral surface for placement proximate a sclera and a well having an opening to said scleral surface; and
an inner core disposed in said well comprising a pharmaceutically active agent, wherein said pharmaceutically active agent is for the treatment of glaucoma, substantially as herein described with reference to at least one of the accompanying drawings.

30. An ophthalmic drug delivery device, comprising:
a body having a scleral surface for placement proximate a sclera and a well having an opening to said scleral surface; and
an inner core disposed in said well comprising a pharmaceutically active agent, wherein said pharmaceutically active agent comprises an angiogenesis inhibitor, substantially as herein described with reference to at least one of the accompanying drawings.

31. An ophthalmic drug delivery device, comprising:
a body having a scleral surface for placement proximate a sclera and a well having an opening to said scleral surface; and

an inner core disposed in said well comprising a pharmaceutically active agent, wherein said pharmaceutically active agent comprises an antimetabolite, substantially as herein described with reference to at least one of the accompanying drawings.

32. An ophthalmic drug delivery device, comprising:
a body having a scleral surface for placement proximate a sclera and a well having an opening to said scleral surface; and
an inner core disposed in said well comprising a pharmaceutically active agent, wherein said pharmaceutically active agent comprises a neuroprotective drug, substantially as herein described with reference to at least one of the accompanying drawings.

33. A method of delivering a pharmaceutically active agent to the eye, said eye having a sclera, a Tenon's capsule, and a macula, comprising the steps of:
providing a tablet having a pharmaceutically active agent disposed therein; and
disposing said tablet on an outer surface of said sclera and below said Tenon's capsule, substantially as herein described with reference to at least one of the accompanying drawings.

DATED this 27th day of February 2004

Alcon Inc

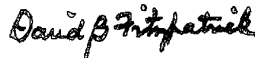

By their patent attorneys

Phillips Ormonde & Fitzpatrick

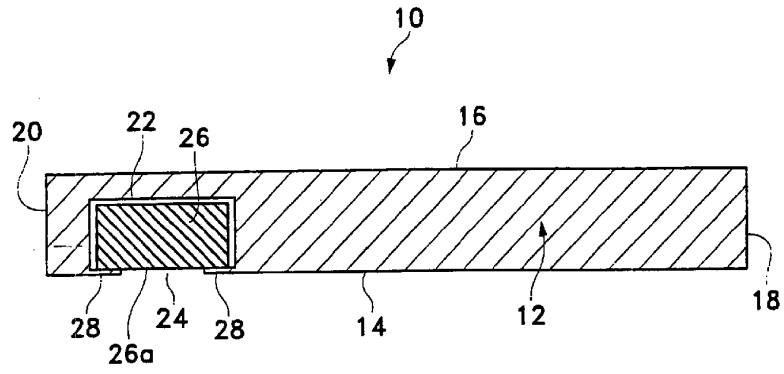

FIG. 1

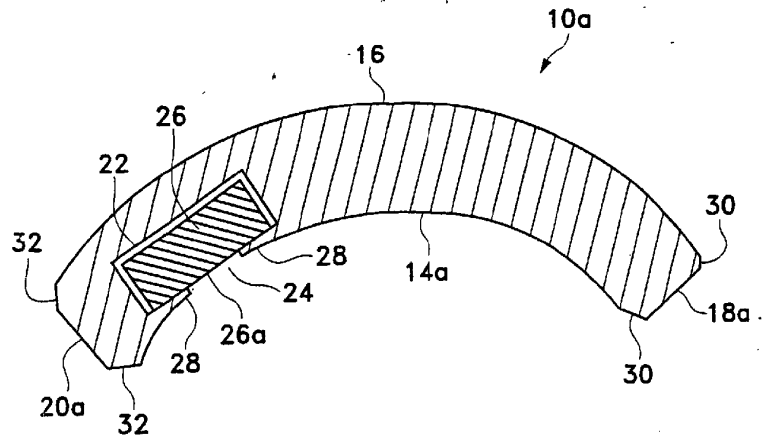

FIG. 2

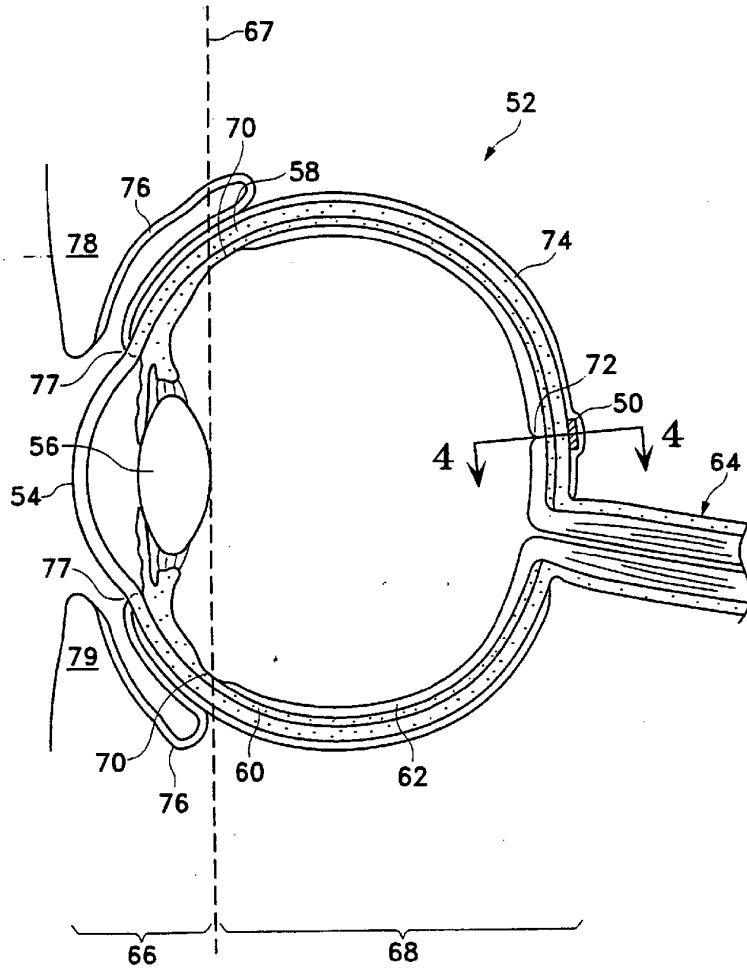

FIG. 3

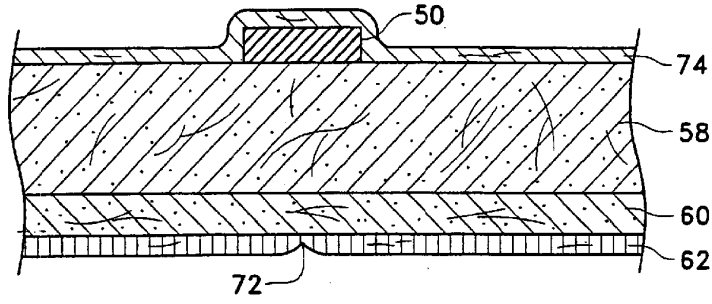

FIG. 4

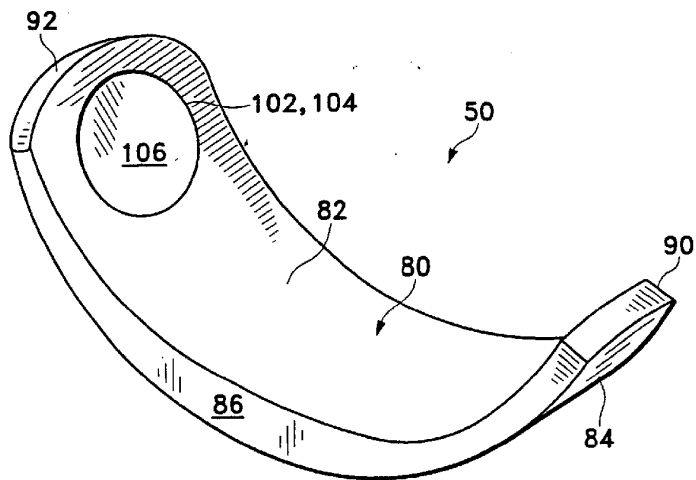

FIG. 5

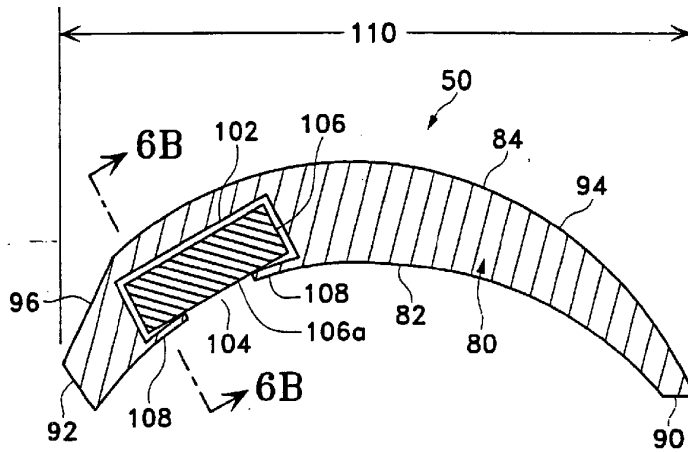

FIG. 6A

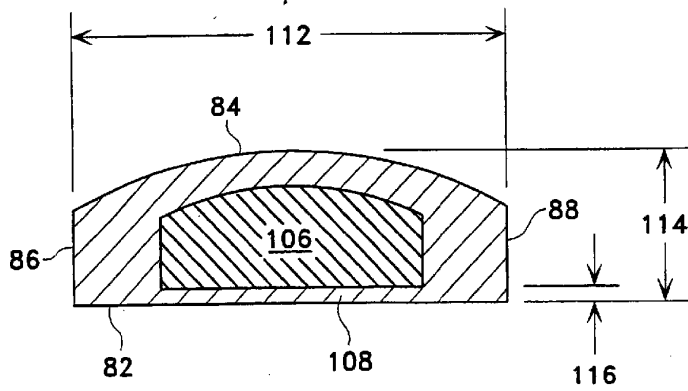

FIG. 6B

5/5

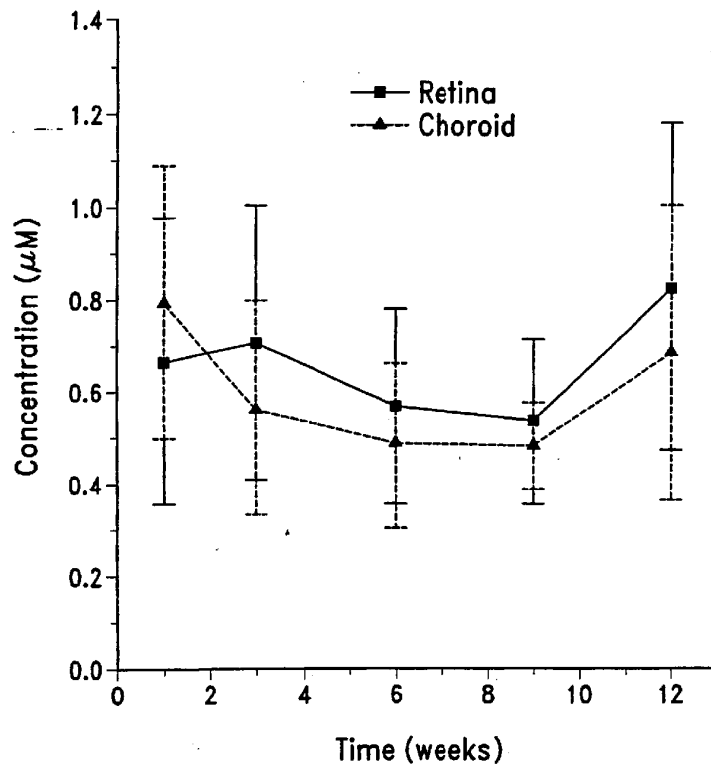

FIG. 7