



US00D332653S

# United States Patent [19]

[11] Patent Number: Des. 332,653

Ryan

[45] Date of Patent: \*\* Jan. 19, 1993

## [54] WELDING OUTLET

[75] Inventor: Bobby W. Ryan, Houston, Tex.

[73] Assignee: WFI International, Inc., Houston, Tex.

[\*\*] Term: 14 Years

[21] Appl. No.: 536,487

[22] Filed: Jun. 12, 1990

[52] U.S. Cl. .... D23/262

[58] Field of Search ..... D23/259-269; 285/189, 286

## [56] References Cited

### U.S. PATENT DOCUMENTS

D. 187,176	2/1960	Jackson .	
D. 187,207	2/1960	Fabian .	
D. 238,876	2/1976	Andersson .	
D. 243,456	2/1977	Ryan .	
D. 243,457	2/1977	Ryan .	
D. 254,266	2/1980	Tableriou .	
D. 262,397	12/1981	Ryan .	
D. 266,351	9/1982	Schneider et al. ....	D23/264
D. 267,505	1/1983	Ryan .	
D. 274,549	7/1984	Ryan .....	D23/263
D. 282,867	3/1986	Ryan et al. ....	D23/259
D. 282,961	3/1986	Ryan .....	D23/259
D. 293,710	1/1988	Woods .....	D23/265
D. 296,580	7/1988	Kirkwood .....	D23/262
1,872,357	8/1932	Straty .	
1,883,439	10/1932	Adams .	
2,015,246	9/1935	Taylor .	
2,495,615	1/1950	Vander Clute .	
2,981,556	4/1961	Jackson .	
3,026,130	3/1962	Morrell .	
3,183,023	5/1965	Morrison .	
3,254,909	6/1966	Ver Nooy .	
3,516,692	6/1970	Albrecht .	
3,594,025	7/1971	Wagner .	
3,894,757	7/1975	Best .	
4,015,321	4/1977	Witter .....	285/286 X
4,103,940	8/1978	Bills .	
4,179,141	12/1979	Newman .....	285/189
4,438,955	3/1984	Ryan .....	285/189
4,541,656	9/1985	Lasko .....	285/189 X

### FOREIGN PATENT DOCUMENTS

16943	3/1934	Australia .....	285/189
-------	--------	-----------------	---------

## OTHER PUBLICATIONS

WFI International, Inc., "Cut branch connection inventories by 50% or more with our new WFI pipet design", 13 pages, 1983.

WFI International, Inc., "An Engineering Solution for Flow Induced Vibration", 1 page, prior to 1989.

WFI International, Inc., Photograph of welding outlet "Collaret", 1 page, 1979.

WFI International, Inc., "Branch Connections for Schedules 5s & 10s Piping", 2 pages, prior to 1989.

WFI International, Inc., "Forged Piping and Vessel Components", 1 page, 1988.

WFI International, Inc., "Branch connections that restore 100% pipe strength", 1 page, prior to 1989.

WFI International, Inc., "Quality forged with a commitment . . . that's WFI International, Inc. and WFI Nuclear Products, Inc.," 2 pages and a flap, prior to 1989.

WFI International, Inc., "Bossett Catalog", 15 pages, dated 1988.

WFI International, Inc., "Flanged Pipet", 2 pages, dated 1989.

Noland Company Industrial Supplies Catalog "T", 1957, p. T598.

WFI International, Inc., "Serving the Oil, Chemical, Pipeline and Energy Industries Throughout the World", 3 pages, prior to 1989.

Primary Examiner—James R. Largen

Attorney, Agent, or Firm—Pravel, Gambrell, Hewitt, Kimball & Krieger

## [57] CLAIM

The ornamental design for a welding outlet, as shown and described.

## DESCRIPTION

FIG. 1 is a top perspective view of a welding outlet showing my new design;

FIG. 2 is a side elevational view thereof, the opposite side being the same as the side shown;

FIG. 3 is side elevational view taken 90 degrees from the side shown in FIG. 2, the opposite side being the same as the side shown;

FIG. 4 is a top plan view thereof; and,

FIG. 5 is a bottom plan view thereof.

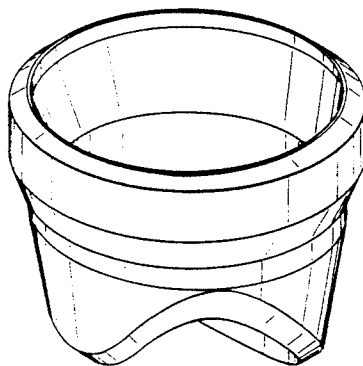

FIG. 1

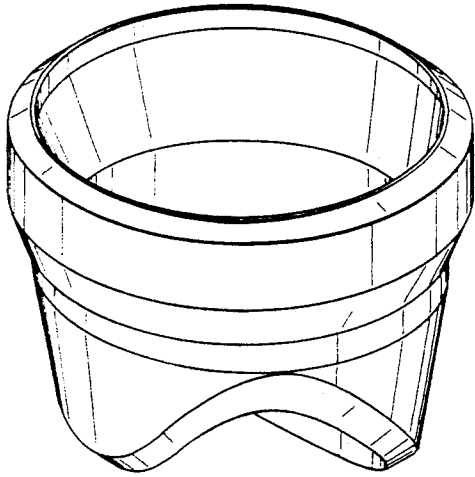

FIG. 4

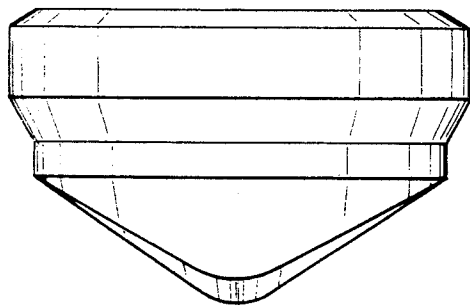
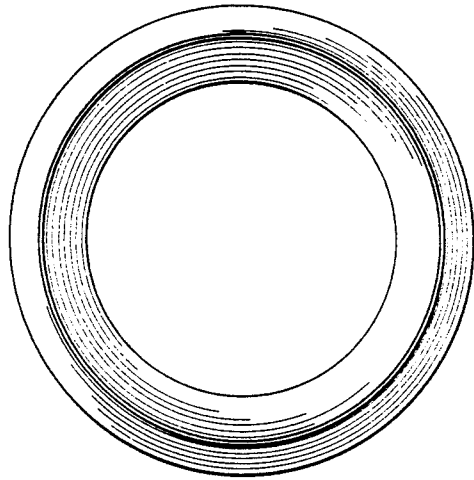

FIG. 2

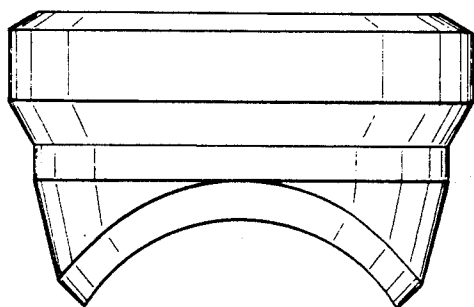

FIG. 3

FIG. 5

