

[54] **AGITATOR BLADE FOR USE BELOW FORMING WIRE OF PAPER MAKING MACHINE**

[75] Inventor: **Dale Bernard Johnson**, Pointe Claire, Quebec, Canada

[73] Assignee: **JWI Ltd.**, Quebec, Canada

[22] Filed: **July 23, 1973**

[21] Appl. No.: **381,557**

[30] **Foreign Application Priority Data**

July 26, 1973 United Kingdom 34855/73

[52] U.S. Cl. **162/308**, 162/209, 162/211, 162/352, 162/374

[51] Int. Cl. **D21f 1/00**, D21f 7/00

[58] Field of Search 162/352, 374, 208, 209, 162/211, 308, 351

[56] **References Cited**

UNITED STATES PATENTS

3,337,394	8/1967	White et al.	162/352
3,446,702	5/1969	Buchanan	162/352 X
3,463,700	8/1969	Brewster et al.	162/308
3,489,644	1/1970	Rhine	162/308 X
3,573,159	3/1971	Sepall	162/352 X
3,778,342	12/1973	Charbonneau	162/352

Primary Examiner—S. Leon Bashore
 Assistant Examiner—Richard H. Tushin
 Attorney, Agent, or Firm—Alan Swabey; Robert E. Mitchell; Guy J. Houle

[57] **ABSTRACT**

An agitating blade located beneath the forming wire of a paper making machine comprises an elongated bar having a top face provided with coplanar upstream and downstream support surfaces for the forming wire intervened by a surface which forms a depression or an agitating channel, and a bottom face provided with T-shaped slot means for slidable attachment to a support member on the paper machine. The surface forming the depression may be curved or may have flat upstream and downstream walls which may be intervened by a bottom wall. The surface of the depression diverges downstream from the upstream support surface at an angle from about 1° to about 8°. The blade width in the machine direction may range from about 1½ inches to about 15 inches. Wear-resistant inserts may be employed in the upstream and downstream support surfaces for the forming wire, and more than one agitating channel may be employed within one elongated bar.

16 Claims, 6 Drawing Figures

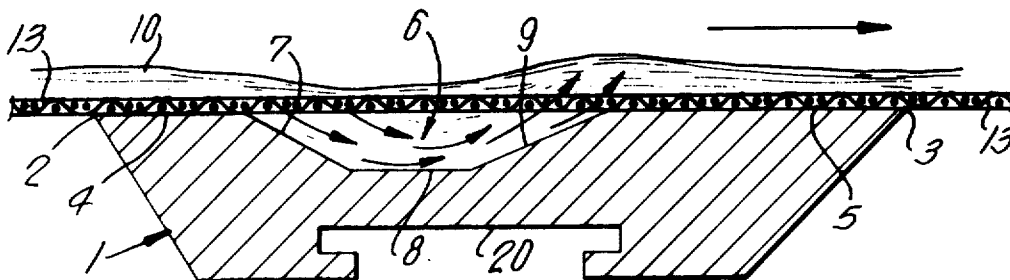

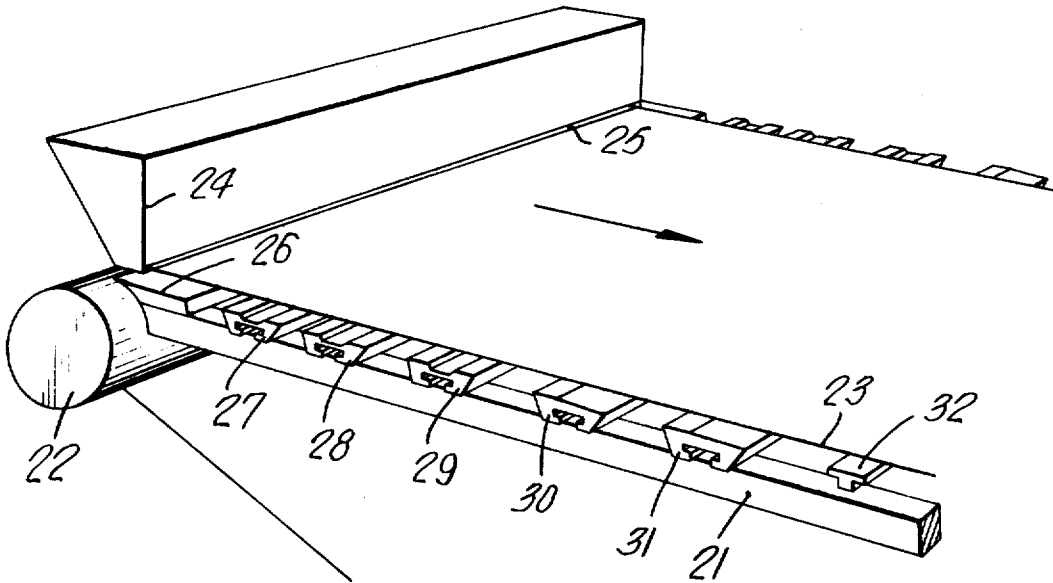

FIG. 1

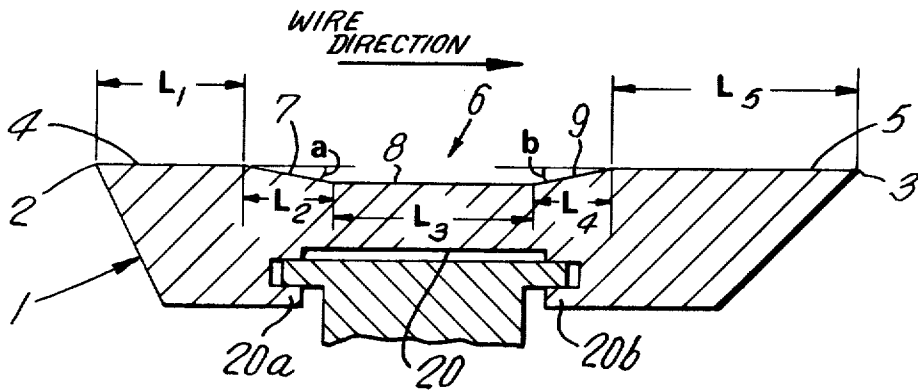
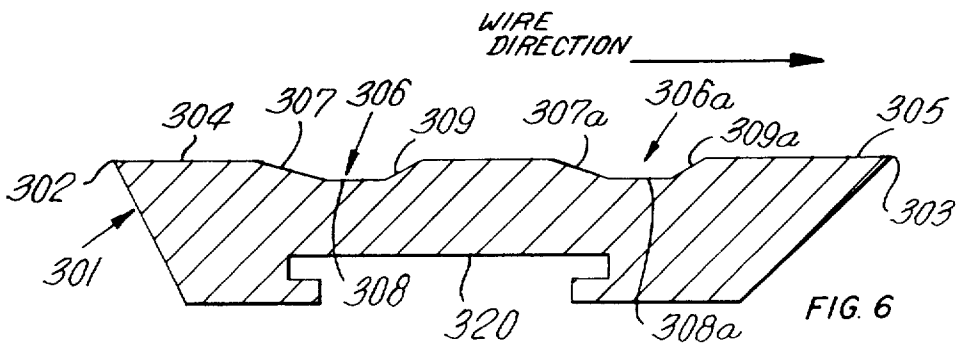
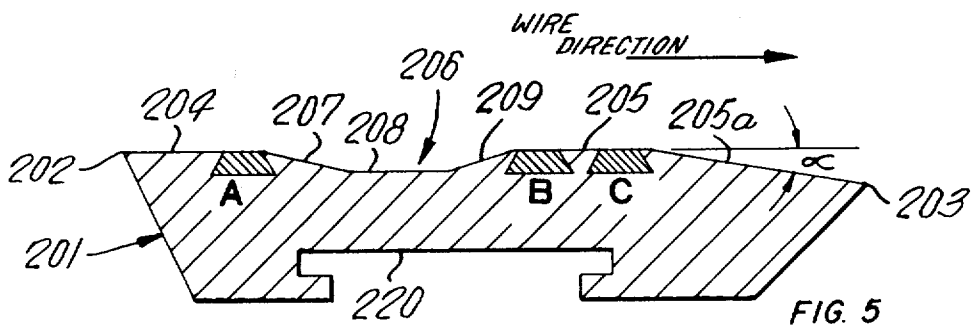
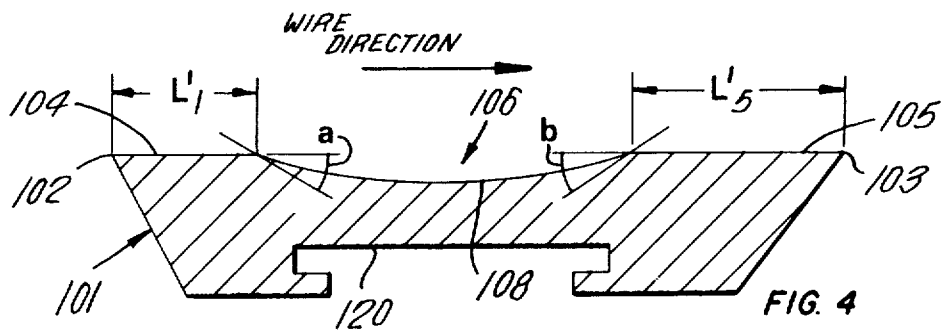
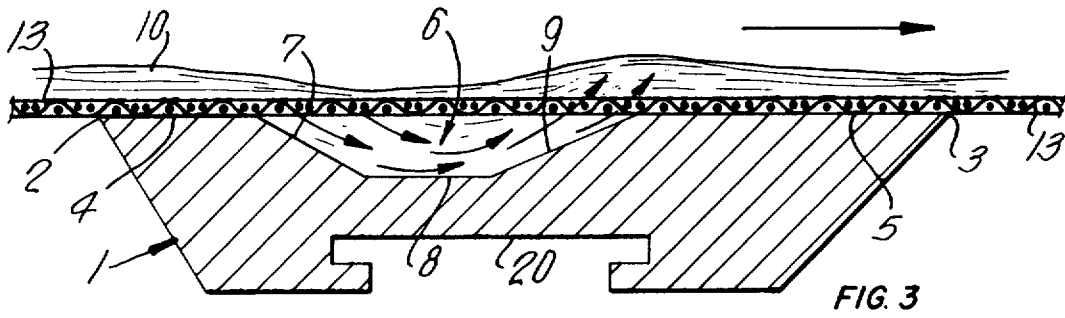

FIG. 2



AGITATOR BLADE FOR USE BELOW FORMING WIRE OF PAPER MAKING MACHINE

BACKGROUND OF THE INVENTION

1. Field of the Invention

This invention relates to apparatus for agitating a pulp suspension web on the forming fabric of a paper-making machine to reduce flocculation.

2. Description of the Prior Art

Paper mill stock supplied to the forming fabric of a paper machine is made up of fibers and solids in an aqueous solution containing generally from about 99 to 99.9 percent water. The aim of the paper maker is to mix the stock thoroughly in the head box of a paper machine so that the fibers will be uniformly dispersed. Despite this attempt, the fibers invariably tend to agglomerate in the head box and emerge from the slice in clumps or flocs and the stock is deposited on the fabric in this condition. If these flocs or fibers remain undispersed, the finished paper will not be of uniform density.

The forming fabric, as used on a conventional paper machine, is an open mesh belt of woven cloth. The warp and weft strands of the cloth may be a metal, for example bronze or stainless steel or a plastic material, for instance polyester in multifilament or monofilament form. The forming fabric of a paper machine is often referred to as a forming wire or simply "wire," and the terms fabric and wire will be used interchangeably below.

Several methods have been proposed and used to redistribute fibers in the stock after it has been transferred to the forming wire or fabric and during the early stages of dewatering. One method that has been used for many years to reduce flocculation is to provide a rapid shaking motion to the Fourdrinier section at its upstream end. In other methods air jets and water jets spray the wet stock either from above or below to agitate and/or re-wet the stock to redistribute the fibers. For the following reasons, such methods have not proven entirely successful, particularly in the case of high speed machines. Machinery required to shake the Fourdrinier is expensive and power-consuming. Redistribution of fibers by air jets or water jets tends to drive excessive amounts of the fibers and solids through the forming wire or fabric, resulting in inefficient operation. The use of water jets to redistribute stock fibers increases the amount of water which ultimately has to be withdrawn from the stock, and therefore, requires additional power-consuming dewatering equipment.

In a deflocculation method recently disclosed in U.S. Pat. No. 3,573,159, O. Sepall, a succession of pressure pulses is applied to the forming stock suspension on the Fourdrinier wire by a series of channels and foils. The geometry of the foils may vary and the specific shape it is alleged, can be determined according to the conditions which exist. In one embodiment of this invention, an elongated surface is placed underneath and engaging the forming wire or fabric extending from one side of it to the other. There is a series of channels in the surface extending across the width of the wire or fabric. The channels have sloping walls and a closed bottom wall. In effect, as the Fourdrinier wire or fabric passes over the elongated surface, water is drained, from the suspension, through the wire or fabric by the supporting surfaces, passes into the channels at their upstream walls and filling the channels is directed upward through

the wire, against the suspension, at the downstream walls. The process is repeated over the series of channels, thus providing rapid pulsation of water upwards and downwards through the wire in the zone equipped with the device. This device is a massive permanent part of the machine requiring considerable supporting structure.

SUMMARY OF THE INVENTION

The present invention aims to overcome these disadvantages of the prior art and to provide certain positive advantages which will be apparent from the following description. The present invention provides an easily replaceable blade, or series of replaceable blade elements, placeable under the Fourdrinier wire or fabric and having specially designed channels to provide pressure pulses through the wire or fabric which produce controlled agitation of the stock.

An attachable blade, according to the invention, is in the form of an elongated bar having top, bottom and upstream and downstream sides. The bottom is provided with means for detachably attaching the blade to the rail of the paper machine. The top extends from an upstream edge to a downstream edge through coplanar upstream and downstream support surfaces for the forming fabric and an intervening depression providing an agitating channel. Preferably, the depression may have a curved surface or a flat upstream wall and downstream walls, which may converge or be intervened by a bottom wall. The upstream wall or curved surface should diverge from the upstream support surface at an angle from about 1° to about 8°. A preferred aspect of the invention is the provision of a wear-resistant insert at the downstream end of the upstream support surface, at the upstream end of the downstream support surface, or both. The blade may be provided with a plurality of spaced apart agitating channels. Other preferred aspects of the blade will be evident from the following description.

The agitator blades of the invention may be constructed of any suitable material, chemically inert, which provides a wear-resistant, low friction surface. A preferred material is high density polyethylene. The agitator blade has mounting means so that it can be readily mounted on a mounting member having complementary keying means. Keying means, according to the invention, is provided by equipping the agitator blade with a T-shaped recess on its underside so that it can be readily slid onto a complementary T-shaped rail and one blade may be replaced by another by simply sliding it off the rail and sliding the other blade on. The blade, thus mounted, is firmly held in accurate angular relationship with the forming wire. This way of attachment, generally referred to as a T-bar mounting, is described in detail in Canadian Pat. No. 717,289, White et al., Sept. 7, 1965 (British Pat. No. 1,084,909).

Standard drainage foils may be replaced by agitator blades, where required, to improve deflocculation under certain operating conditions, providing flexibility not found in the prior art. The combination of specially designed channels in the easily replaceable blade elements provides instant versatility to meet a wide variety of paper-making conditions. Individual blades, having particular activating capabilities, may be installed even while the paper machine is operating.

BRIEF DESCRIPTION OF THE DRAWINGS

Having generally described the invention, it will be

referred to in more detail by reference to the accompanying drawings, which illustrate preferred embodiments, and in which:

FIG. 1 is a perspective view, illustrating schematically the forming section of a conventional paper-making machine equipped with channelled blade elements according to the invention;

FIG. 2 is a schematic cross-section on a larger scale through one embodiment of agitator blade;

FIG. 3 is an exaggerated view of the section of FIG. 2 showing how the agitating effect is produced;

FIG. 4 is a schematic section showing a continuously curved channel;

FIG. 5 is a schematic cross-section showing a channelled blade and having also a divergent foiling angle at the downstream support surface;

FIG. 6 is a schematic section showing a blade having more than one channel.

DESCRIPTION OF THE PREFERRED EMBODIMENTS

Referring to FIG. 1, 21 is the side rail of a paper machine, 22 is the breast roll over which a Fourdrinier wire 23 passes and 24 is a head box with a slice 25. 26 is a forming board and 27, 28 and 29 are detachable agitator blades extending the width of the machine. 30 and 31 are detachable foil blades shown here as they might be placed in the secondary de-watering stages of the paper-making. 32 is a T-shape rail upon which an individual blade is mounted.

In the embodiment of the invention, as shown in FIG. 2, 1 is the agitator blade, which may be made from a solid bar of plastic or other material, for example by machining. The blade has top, bottom and upstream and downstream sides providing a leading edge 2, a trailing edge 3, an upstream flat support surface 4 for the forming fabric, a downstream flat support surface 5, which is coplanar with the surface 4, and a channel 6. The channel 6 intervenes the support surfaces 4 and 5 and comprises three discrete, preferably flat surfaces, forming an upstream wall 7, a floor or bottom wall 8 and a downstream wall 9. The wall 7 diverges downstream from 4 at an angle a which should be from 1° to 8° . Wall 9 diverges upstream from 5 at an angle b which may be from 1° to 70° . The upstream and downstream walls join the floor 8, which may be parallel to the support surfaces 4 and 5 or at an angle to these surfaces.

The precise shape and dimensions of the channel will depend on the degree of agitation required and other factors. Referring to the L-dimensions shown to represent the lengths of the various flat surfaces on the top side of the blade, these will generally range as follows:

L1	$\frac{3}{8}$ " to 1"
L2	$\frac{1}{4}$ " to 3"
L3	0" to 5"
L4	$\frac{1}{4}$ " to 3"
L5	$\frac{1}{8}$ " to 3"

The lengths L1 and L5 are not critical, but should be long enough to provide a reasonably water-tight seal between the forming wire and the blade. L5 will, in some cases, be longer than L1 to provide a more effective seal at the downstream side to overcome the momentum of the water in the channel so that it may be directed upwards through the wire 13.

The length of L3 will influence the total length of the channel and, in certain cases, where a short channel is required L3 may be zero and L2 will simply join L4 at the bottom of the channel.

The total length of the blade in the machine direction may range from about $1\frac{1}{2}$ to about 15 inches and depending on the length of the blade and other factors, the total length of the agitating channel may range from about $\frac{1}{2}$ to about 11 inches. The thickness of the blade may range from about $\frac{1}{2}$ to about 2 inches, depending on compatibility with other agitator blades or foils in the system.

Again referring to FIG. 2, 20 is the T-recess having opposed locking flanges 20a and 20b for slidable attachment to a T-bar or rail mounted on a frame which extends across the machine underneath the Fourdrinier wire. This way of mounting is described in connection with foils in U.S. Pat. No. 3,337,394, White and Buchanan (1967), the disclosure of which is hereby incorporated by reference.

In more detail, the blade has a T-shaped longitudinally extending recess terminating in the bottom surface. The width of the T-shaped recess is greater than the corresponding width of the T-shaped rail to be received in the T-shaped recess to provide a clearance between the side edges of the upper portion of the T-bar and the opposed side walls of the T-shaped recess. The T-shaped recess further includes an upper wall surface substantially parallel to the forming wire or fabric when the blade is operatively installed in the paper machine and inwardly projecting flange means at the upstream and downstream edges extend from opposite side walls of the T-shaped recess for underlying and slidably engaging the underside of the upper portions of the T-shaped rail to be received in the T-shaped recess. The vertical spacing between the upper wall surface of the T-shaped recess and the opposed upper surfaces of the inwardly projecting flange means is such that when the blade is operatively mounted on the T-shaped rail at least the upper surface of the inwardly projecting flange at the downstream edge of the blade will be firmly inter-engaged with the underside of the overlying upper portion of the T-shaped rail. And, the upper wall surface of the T-shaped recess will be firmly inter-engaged with the upper surface of the T-shaped rail so as to maintain the position of the support surfaces of the blade. Desirably projecting flange means at the upstream and downstream edges of the blade each have an upper surface substantially parallel to the upper wall surface of the recess for slidably engaging the underside of the upper portion of the T-shaped rail member to be received in the T-shaped recess. The upper wall surface of the T-shaped recess may define a longitudinally extending groove so as to reduce the area of contact between the blade and the T-shaped rail and thereby facilitate relative longitudinal sliding movement between the blade and the rail. Opposed side walls of the T-shaped recess in the blade preferably extend substantially normal to the upper wall surface of the T-shaped recess.

In FIG. 3 it is shown that, as the Fourdrinier wire 13 moves over the agitator blade 1 in the direction from left to right (as indicated by the arrow), water is drawn from the stock 10 through the wire and onto surfaces 7 and 8 of channel 6. The stock becomes partially de-watered and compressed as the fibers tend to form a mat which, as explained, will contain flocs. As the wire

continues to move across the blade, water in the channel 6 flows downstream and is directed upwards against sloping wall 9 from where it is forced through the wire again and into the stock. The upward flow of water will re-wet the stock and break up flocs so that fibers are redistributed more evenly.

Other embodiments of the invention will now be discussed.

In one other embodiment, shown in FIG. 4, the surface of the channel 106 is in the form of a continuous curve rather than being made up of several discrete surface sections as shown in FIG. 2. The curve would, depending on paper machine and stock conditions, have a tangent angle a at the upstream side equal to from 1° to 8° and a tangent angle b at the downstream side of from 1° to 50° . The curved section may be that of a circle, an ellipse, a parabola, or a hyperbola, or a combination of these and depends, actually, with some limitation, upon the ease with which the channel can be fabricated. The total depth of the channel would be limited to approximately 0.2 inches from a minimum of about 0.01 inches.

In still another embodiment of the invention, shown in FIG. 5, the T-bar method of attachment may be used in cases where the downstream support surface 205 of an agitator blade has a part 205a having a divergent foiling angle shown as α and thus incorporates, in the same blade, the feature of a drainage foil as well as an agitator.

In still another embodiment of the invention, shown in FIG. 6, the T-bar method of attachment may be used in cases where the agitator blade has several channels 306 and 306a. The channels 306 and 306a may, as with the single-channel type, be formed by several discrete surface sections or by a continuous curve.

In still another embodiment, the agitator blade or combined agitator and drainage foil blade may be equipped with hard-wearing inserts in those areas of the support surfaces which contact the forming medium and maximum wear occurs, for example in the zone where the support surfaces meet the agitating channel surfaces. Hard-wearing inserts are shown as A, B and C in FIG. 5. The use of such inserts is described in detail in U.S. Pat. 3,446,702, May 27, 1969, Buchanan (British Pat. No. 1,160,699), the disclosure of which is hereby incorporated by reference.

Preferably the construction of the blade to include the wear-resistant inserts is as follows, considering the insert on the upstream support surface as an example. Referring to FIG. 5, the upstream support surface 204 is provided with an undercut groove extending longitudinally of the blade. The groove has an upstream upper edge parallel to and spaced from the upstream edge of the support surface in the direction of forming fabric movement. The insert A is mounted in the groove and has a cross-section corresponding to that of the groove. The insert A has a fabric-engaging upper surface coplanar with the support surface. At least the upper surface portion of the insert is made of abrasion resistant material. The insert may be made up of a plurality of short sections disposed in end-to-end relationship in the groove. Desirably the groove and insert have a downstream upper edge extending along and coinciding with the junction of the support surface and agitating channel. The mounting of the insert in the downstream support surface is similar. As shown in FIG. 5, a support surface may have more than one insert.

In practical operation, on a paper machine, more than one agitator blade is generally used and a series of such blades may be installed so that the distance between blades allows for partial or total subsidence of turbulence in the sheet being formed. In this way effective redistribution of stock fibers is attained without the necessity of adding more water. The ease with which the blades may be installed or removed from the T-bar mounting rails even when the machine is running makes it possible to attain a high degree of control over the deflocculation process with the result that a uniform sheet of paper is obtained with a high degree of efficiency.

The surfaces 4 and 5 must be long enough to supply an adequate seal that is to prevent air being drawn into the channel. The surface 5 is preferably longer than the surface 4, to prevent escape of water between the blade and wire or fabric. The angle of the surface 7 should be sharp enough to provide a foiling action, that is drawing water down from the stock through the wire or fabric, but not too sharp or the desired drawing down of water would not occur. Likewise the angle of the surface 9 should not be too sharp or the wire or fabric would be pushed up and allow escape of water between the wire or fabric and the surface 5.

The invention makes possible great flexibility in the use of the blades to accomplish various effects. For example, there may be employed various arrangements of blade spacing, differences in shape and size of the agitating channel from blade to blade, and the interspersing of blades and foils.

The precise quantitative criteria, as will be understood by those skilled in the art, depends, inter alia, on the mesh size of the wire or fabric, its speed, and the condition of the stock. Coping with these variations makes the present invention particularly advantageous since one blade can be readily substituted for another to provide appropriate calibration of the various parts of the blade to meet the practical conditions of operation. The present invention is specially useful for empirically determining the optimum parameters for different conditions through trial and error. By employing this invention it is possible to substitute combinations of differently calibrated blades until an appropriate combination is found.

Among the advantages provided by the invention are the following:

1. The agitator blades are easily detachable and replaceable by sliding them off and on their mounting rails.
2. The mounting provides secure and accurate positioning of the blades.
3. Individual mounting of blade units makes it possible to provide adequate agitation for a wide variety of paper machine and stock conditions.
4. Agitator blades, according to the invention, are easy to make, since their limited size makes them readily machineable.
5. Channels of various dimensions can be readily provided in interchangeable blades to provide for maximum deflocculation with minimum bubble formation.
6. Blade changes can be made while the machine is in operation.
7. Fines do not accumulate to a significant degree on a T-bar rail when a blade is not installed on the rail.

8. Wear-resistant surfaces can be incorporated at the locations of heavy wear.

I claim:

- 1. An attachable-detachable agitating device for placing in supporting relationship to the forming wire of a paper making machine and extending thereacross transversely of the direction of wire travel, comprising, a blade having a relatively narrow elongated thin body provided with a top face, a bottom, and free upstream and free downstream faces, the body being provided with a keying slot entering at the bottom and extending the length of the body for slidably receiving a complementary shaped key support member of the paper machine, the top face being provided with an upstream support surface terminating in an upstream edge where the wire first encounters the blade, a downstream support surface terminating in a downstream edge where the wire leaves the blade and an intermediate surface extending downwardly from the upstream support surface and upwardly to the downstream support surface to provide an agitating channel for drawing water from and forcibly returning it to the stock.
- 2. A device, as defined in claim 1, in which the surface of the said intermediate surface is curved throughout.
- 3. A device, as defined in claim 1, in which the said intermediate surface has a flat upstream wall at an angle to the support surfaces.
- 4. A device, as defined in claim 1, in which the said intermediate surface has a flat upstream wall and a flat downstream wall each at an angle to the support surfaces.
- 5. A device, as defined in claim 1, in which the upstream and downstream walls are intervened by a bottom wall.
- 6. A device, as defined in any of claim 1, in which the surface of said intermediate surface diverges downstream from the upstream support surface at an angle from about 1° to about 8°.
- 7. A device, as defined in claim 1, in which the width in the machine direction is between about 1½ and about 15 inches.
- 8. A device, as defined in claim 1, in which the means for attachment to the paper machine is a T-shaped slot

entering the bottom of the blade.

9. A device, as defined in claim 1, which is provided with a wear-resistant insert at the downstream end of the upstream support surface.

5 10. A device, as defined in claim 1, which is provided with a wear-resistant insert at the upstream end of the downstream support surface.

10 11. A device, as defined in claim 1, which is provided with respective wear-resistant inserts at the downstream end of the upstream support surface and at the upstream end of the downstream support surface.

12. A device, as defined in claim 1, which is provided with a spaced-apart means forming multiple parallel agitating channels.

15 13. A paper machine, comprising, a frame, upstream and downstream means on said frame carrying and endless forming wire for a run therebetween, through an initial dewatering section of an upper run,

20 a plurality of separate thin elongated blades with means for removably mounting on the frame and extending from one side to the other of the forming wire and having supporting surfaces contacting the undersurface of the upper run of the wire,

at least one of the blades in said dewatering section being an agitating blade having upstream and downstream wire supporting surface intervened by means sloping downwardly and then upwardly, and forming therebetween an agitating channel for agitating the fibers by drawing water from the web and passing it back again through the forming wire, a next adjacent downstream blade being spaced from said agitating blade to provide between it and the agitating blade a free space across which the wire runs open to the atmosphere to permit subsidence of turbulence in the web.

14. A paper machine, as defined in claim 13, in which there are a plurality of said agitating blades mounted in series.

15. A paper machine, as defined in claim 13, in which there is at least one foil blade mounted in series with the agitating blade.

16. A paper machine, as defined in claim 13, in which foil blades and agitating blades are interspersed.

* * * * *

50

55

60

65