

(19) World Intellectual Property Organization
International Bureau



(43) International Publication Date
13 October 2005 (13.10.2005)

PCT

(10) International Publication Number
WO 2005/095751 A1

- (51) International Patent Classification⁷: **E21B 7/12** 29331 Lachendorf (DE). **KRUEGER, Volker**; Sassen-
garten 8, 29223 Celle (DE).
- (21) International Application Number: PCT/US2005/009736 (74) Agents: **RIDDLE, Albert, J.** et al.; Baker Hughes Incor-
porated, 3900 Essex Lane, Suite 1200, Houston, TX 77027
(US).
- (22) International Filing Date: 23 March 2005 (23.03.2005)
- (25) Filing Language: English (81) Designated States (unless otherwise indicated, for every
kind of national protection available): AE, AG, AL, AM,
AT, AU, AZ, BA, BB, BG, BR, BW, BY, BZ, CA, CH, CN,
CO, CR, CU, CZ, DE, DK, DM, DZ, EC, EE, EG, ES, FI,
GB, GD, GE, GH, GM, HR, HU, ID, IL, IN, IS, JP, KE,
KG, KP, KR, KZ, LC, LK, LR, LS, LT, LU, LV, MA, MD,
MG, MK, MN, MW, MX, MZ, NA, NI, NO, NZ, OM, PG,
PH, PL, PT, RO, RU, SC, SD, SE, SG, SK, SL, SM, SY, TJ,
TM, TN, TR, TT, TZ, UA, UG, US, UZ, VC, VN, YU, ZA,
ZM, ZW.
- (26) Publication Language: English (84) Designated States (unless otherwise indicated, for every
kind of regional protection available): ARIPO (BW, GH,
GM, KE, LS, MW, MZ, NA, SD, SL, SZ, TZ, UG, ZM,
- (30) Priority Data: 10/809,648 25 March 2004 (25.03.2004) US
- (71) Applicant (for all designated States except US): **BAKER HUGHES INCORPORATED** [US/US]; 3900 Essex Lane, Suite 1200, Houston, TX 77027 (US).
- (72) Inventors: **KRUEGER, Sven**; Runde Strasse 39, 29308 Winsen/Aller (DE). **GRIMMER, Harald**; Im Gehege 8,

[Continued on next page]

(54) Title: MODULAR DESIGN FOR DOWNHOLE ECD-MANAGEMENT DEVICES AND RELATED METHODS

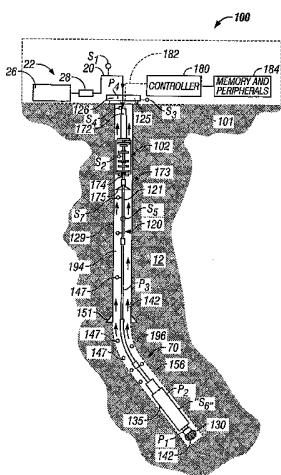

A

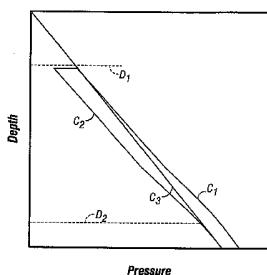

B

(57) Abstract: One or more components of a wellbore drilling assembly utilize a modular construction to facilitate assembly, disassembly, repair and/or maintenance of a wellbore drilling assembly and/or to extend the overall operating capabilities of the drilling assembly. In one embodiment, a modular construction is used for an APD Device (170) a motor driving the modular APD Device, a comminution device, and an annular seal. Individual modules can be configured have different operating set points, operating parameters and characteristics sand/or to extend the overall operating capabilities of (the drilling assem+y. In one embodiment, a modular construction is used for an APD Device, a motor driving the modular APD Device, a comminution device, and an annular seal. Individual modules can be configure have different operating s et points, operating parameters and characteristics (e.g., rotational speeds, flow rates, pressure differentials, etc.) and/or different responses to given environmental factors or conditions (e.g. pressure, temperature, wellbore fluid chemistry, etc.). In one embodiment, the high-pressure seals used in conjuctio with the APD Device and/or motor is a hydrodynamic seal that provides a selected leak or flow rates. Optionally, the seal is modular to provide different degrees of leak rates and/or different functional characteristics.

WO 2005/095751 A1



ZW), Eurasian (AM, AZ, BY, KG, KZ, MD, RU, TJ, TM),
European (AT, BE, BG, CH, CY, CZ, DE, DK, EE, ES, FI,
FR, GB, GR, HU, IE, IS, IT, LT, LU, MC, NL, PL, PT, RO,
SE, SI, SK, TR), OAPI (BF, BJ, CF, CG, CI, CM, GA, GN,
GQ, GW, ML, MR, NE, SN, TD, TG).

For two-letter codes and other abbreviations, refer to the "Guidance Notes on Codes and Abbreviations" appearing at the beginning of each regular issue of the PCT Gazette.

Published:

— *with international search report*

TITLE:

Modular Design for Downhole ECD-Management Devices and Related Methods

Modular Design for Downhole ECD-Management Devices and Related Methods

CROSS-REFERENCE TO RELATED APPLICATIONS

This application is a continuation-in-part of U.S. Patent Application serial number 10/783,471 filed Feb. 20th, 2004, which is a continuation of U.S. Patent Application serial number 10/251,138 filed Sept. 20th, 2002, which 5 takes priority from U.S. provisional patent application serial number 60/323,803 filed on September 20, 2001, titled "Active Controlled Bottomhole Pressure System and Method."

This application is a continuation-in-part of U.S. Patent Application 10 10/716,106 filed on Nov. 17th, 2003, which is a continuation of U.S. Patent Application 10/094,208, filed Mar. 8, 2002, now U.S. Pat. No. 6,648,081 granted on Nov. 18, 2003, which is a continuation of U.S. application Ser. No. 09/353,275, filed Jul. 14, 1999, now U.S. Pat. No. 6,415,877, which claims benefit of U.S. Provisional Application No. 60/108,601, filed Nov. 16, 1998, 15 U.S. Provisional Application No. 60/101,541, filed Sep. 23, 1998, U.S. Provisional Application No. 60/092,908, filed, Jul. 15, 1998 and U.S. Provisional Application No. 60/095,188, filed Aug. 3, 1998.

Field of the Invention

20 This invention relates generally to oilfield wellbore drilling systems and more particularly to drilling systems that utilize active control of bottomhole pressure or equivalent circulating density during drilling of the wellbores.

Background of the Art

Oilfield wellbores are drilled by rotating a drill bit conveyed into the wellbore by a drill string. The drill string includes a drill pipe (tubing) that has at its bottom end a drilling assembly (also referred to as the "bottomhole assembly" or "BHA") that carries the drill bit for drilling the wellbore. The drill pipe is made of jointed pipes. Alternatively, coiled tubing may be utilized to carry the drilling assembly. The drilling assembly usually includes a drilling motor or a "mud motor" that rotates the drill bit. The drilling assembly also includes a variety of sensors for taking measurements of a variety of drilling, formation and BHA parameters. A suitable drilling fluid (commonly referred to as the "mud") is supplied or pumped under pressure from a source at the surface down the tubing. The drilling fluid drives the mud motor and then discharges at the bottom of the drill bit. The drilling fluid returns uphole via the annulus between the drill string and the wellbore inside and carries with it pieces of formation (commonly referred to as the "cuttings") cut or produced by the drill bit in drilling the wellbore.

For drilling wellbores under water (referred to in the industry as "offshore" or "subsea" drilling) tubing is provided at a work station (located on a vessel or platform). One or more tubing injectors or rigs are used to move the tubing into and out of the wellbore. In riser-type drilling, a riser, which is formed by joining sections of casing or pipe, is deployed between the drilling vessel and the wellhead equipment at the sea bottom and is utilized to guide the tubing to the wellhead. The riser also serves as a conduit for fluid returning from the wellhead to the sea surface.

During drilling, the drilling operator attempts to carefully control the fluid density at the surface so as to control pressure in the wellbore, including the bottomhole pressure. Typically, the operator maintains the hydrostatic pressure of the drilling fluid in the wellbore above the formation or pore 5 pressure to avoid well blow-out. The density of the drilling fluid and the fluid flow rate largely determine the effectiveness of the drilling fluid to carry the cuttings to the surface. One important downhole parameter controlled during drilling is the bottomhole pressure, which in turn controls the equivalent circulating density ("ECD") of the fluid at the wellbore bottom.

10

This term, ECD, describes the condition that exists when the drilling mud in the well is circulated. The friction pressure caused by the fluid circulating through the open hole and the casing(s) on its way back to the surface, causes an increase in the pressure profile along this path that is 15 different from the pressure profile when the well is in a static condition (i.e., not circulating). In addition to the increase in pressure while circulating, there is an additional increase in pressure while drilling due to the introduction of drill solids into the fluid. This negative effect of the increase in pressure along the annulus of the well is an increase of the pressure which can fracture the 20 formation at the shoe of the last casing. This can reduce the amount of hole that can be drilled before having to set an additional casing. In addition, the rate of circulation that can be achieved is also limited. Also, due to this circulating pressure increase, the ability to clean the hole is severely restricted. This condition is exacerbated when drilling an offshore well. In

offshore wells, the difference between the fracture pressures in the shallow sections of the well and the pore pressures of the deeper sections is considerably smaller compared to on shore wellbores. This is due to the seawater gradient versus the gradient that would exist if there were soil
5 overburden for the same depth.

In some drilling applications, it is desired to drill the wellbore at at-balance condition or at under-balanced condition. The term at-balance means that the pressure in the wellbore is maintained at or near the formation
10 pressure. The under-balanced condition means that the wellbore pressure is below the formation pressure. These two conditions are desirable because the drilling fluid under such conditions does not penetrate into the formation, thereby leaving the formation virgin for performing formation evaluation tests and measurements. In order to be able to drill a well to a total wellbore depth
15 at the bottomhole, ECD must be reduced or controlled. In subsea wells, one approach is to use a mud- filled riser to form a subsea fluid circulation system utilizing the tubing, BHA, the annulus between the tubing and the wellbore and the mud filled riser, and then inject gas (or some other low density liquid) in the primary drilling fluid (typically in the annulus adjacent the BHA) to
20 reduce the density of fluid downstream (i.e., in the remainder of the fluid circulation system). This so-called "dual density" approach is often referred to as drilling with compressible fluids.

Another method for changing the density gradient in a deepwater

return fluid path has been proposed, but not used in practical application. This approach proposes to use a tank, such as an elastic bag, at the sea floor for receiving return fluid from the wellbore annulus and holding it at the hydrostatic pressure of the water at the sea floor. Independent of the flow in

5 the annulus, a separate return line connected to the sea floor storage tank and a subsea lifting pump delivers the return fluid to the surface. Although this technique (which is referred to as "dual gradient" drilling) would use a single fluid, it would also require a discontinuity in the hydraulic gradient line between the sea floor storage tank and the subsea lifting pump. This requires

10 close monitoring and control of the pressure at the subsea storage tank, subsea hydrostatic water pressure, subsea lifting pump operation and the surface pump delivering drilling fluids under pressure into the tubing for flow downhole. The level of complexity of the required subsea instrumentation and controls as well as the difficulty of deployment of the system has delayed

15 (if not altogether prevented) the practical application of the "dual gradient" system.

Another approach is described in U.S. Patent Application No. 09/353,275, filed on July 14, 1999 and assigned to the assignee of the

20 present application. The U.S. Patent Application No. 09/353,275 is incorporated herein by reference in its entirety. One embodiment of this application describes a riser less system wherein a centrifugal pump in a separate return line controls the fluid flow to the surface and thus the equivalent circulating density.

The present invention provides a wellbore system wherein the bottomhole pressure and hence the equivalent circulating density is controlled by creating a pressure differential at a selected location in the return fluid path with an active pressure differential device to reduce or control the bottomhole pressure. The present system is relatively easy to incorporate in new and existing systems.

SUMMARY OF THE INVENTION

10 The present invention provides wellbore systems for performing downhole wellbore operations for both land and offshore wellbores. Such drilling systems include a rig that moves an umbilical (e.g., drill string) into and out of the wellbore. A bottomhole assembly, carrying the drill bit, is attached to the bottom end of the drill string. A well control assembly or equipment on 15 the well receives the bottomhole assembly and the tubing. A drilling fluid system supplies a drilling fluid into the tubing, which discharges at the drill bit and returns to the well control equipment carrying the drill cuttings via the annulus between the drill string and the wellbore. A riser dispersed between the wellhead equipment and the surface guides the drill string and provides a 20 conduit for moving the returning fluid to the surface.

In one embodiment of the present invention, an active pressure differential device moves in the wellbore as the drill string is moved. In an alternative embodiment, the active differential pressure device is attached to

the wellbore inside or wall and remains stationary relative to the wellbore during drilling. The device is operated during drilling, *i.e.*, when the drilling fluid is circulating through the wellbore, to create a pressure differential across the device. This pressure differential alters the pressure on the wellbore below or downhole of the device. The device may be controlled to reduce the bottomhole pressure by a certain amount, to maintain the bottomhole pressure at a certain value, or within a certain range. By severing or restricting the flow through the device, the bottomhole pressure may be increased.

10

The system also includes downhole devices for performing a variety of functions. Exemplary downhole devices include devices that control the drilling flow rate and flow paths. For example, the system can include one or more flow-control devices that can stop the flow of the fluid in the drill string and/or the annulus. Such flow-control devices can be configured to direct fluid in drill string into the annulus and/or bypass return fluid around the APD device. Another exemplary downhole device can be configured for processing the cuttings (*e.g.*, reduction of cutting size) and other debris flowing in the annulus. For example, a comminution device can be disposed in the annulus upstream of the APD device.

20

In a preferred embodiment, sensors communicate with a controller via a telemetry system to maintain the wellbore pressure at a zone of interest at a selected pressure or range of pressures. The sensors are strategically

positioned throughout the system to provide information or data relating to one or more selected parameters of interest such as drilling parameters, drilling assembly or BHA parameters, and formation or formation evaluation parameters. The controller for suitable for drilling operations preferably 5 includes programs for maintaining the wellbore pressure at zone at under-balance condition, at at-balance condition or at over-balanced condition. The controller may be programmed to activate downhole devices according to programmed instructions or upon the occurrence of a particular condition.

10 Exemplary configurations for the APD Device and associated drive includes a moineau-type pump coupled to positive displacement motor/drive via a shaft assembly. Another exemplary configuration includes a turbine drive coupled to a centrifugal-type pump via a shaft assembly. Preferably, a high-pressure seal separates a supply fluid flowing through the motor from a 15 return fluid flowing through the pump. In a preferred embodiment, the seal is configured to bear either or both of radial and axial (thrust) forces.

In still other configurations, a positive displacement motor can drive an intermediate device such as a hydraulic motor, which drives the APD Device. 20 Alternatively, a jet pump can be used, which can eliminate the need for a drive/motor. Moreover, pumps incorporating one or more pistons, such as hammer pumps, may also be suitable for certain applications. In still other configurations, the APD Device can be driven by an electric motor. The electric motor can be positioned external to a drill string or formed integral

with a drill string. In a preferred arrangement, varying the speed of the electrical motor directly controls the speed of the rotor in the APD device, and thus the pressure differential across the APD Device.

5 Bypass devices are provided to allow fluid circulation in the wellbore during tripping of the system, to control the operating set points of the APD Device and/or associated drive/motor, and to provide a discharge mechanism to relieve fluid pressure. For examples, the bypass devices can selectively channel fluid around the motor/drive and the APD Device and selectively 10 discharge drilling fluid from the drill string into the annulus. In one arrangement, the bypass device for the pump can also function as a particle bypass line for the APD device. Alternatively, a separate particle bypass can be used in addition to the pump bypass for such a function. Additionally, an annular seal (not shown) in certain embodiments can be disposed around the 15 APD device to enable a pressure differential across the APD Device.

In certain embodiments of the present invention, one or more of the above-described components utilize a modular construction (*i.e.*, formed as 20 modules having a standardized construction). Modular construction facilitates repair and/or maintenance of a wellbore drilling assembly by enabling the component needing work to be readily removed from the drilling assembly. Additionally, the modular construction can enhance the overall operating capabilities of the drilling assembly. Generally speaking, components of a

drilling assembly have operating set points, operating parameters and characteristics that, if changed, can increase or decrease overall drilling efficiency. An exemplary, but not exclusive, list of such set points, operating parameters and characteristics includes: rotational speed, pressure
5 differentials in the supply fluid or return fluid, torque output, and fluid flow rate. Moreover, the drilling environment can also impact drilling efficiency. Exemplary environmental factors or conditions that influence drilling efficiency include loadings (stress, strain), temperature, wellbore fluid chemistry, cutting composition, and volume of cuttings in the return fluid. Modular components
10 that are configured to have a specified operating parameter or operate in a particular environmental condition can be changed out as environmental conditions change and/or as different operating parameters are needed to provide optimal operation.

By way of illustration, components of a wellbore drilling assembly that
15 are amenable to modular construction include the APD Device, the motor driving the modular APD Device, the comminution device, and the annular seal. Suitable modular pumps can be configured to operate at different rotational speeds, flow rates, and pressure differentials. Other embodiments of modular pumps can generate the given pressure differential using multiple
20 stages. Modular motors can be designed to have different operating RPM and/or torque. Modular comminution devices can be configured for optimal performance under a different operating parameter such a selected flow rate, cutting composition, rotational speed of the driving mechanism, and volume of cuttings in the return fluid. Modular annular seals can be constructed for

specified wellbore diameters or ranges of wellbore diameters as well as environmental conditions such as wellbore pressures and wellbore fluid chemistry.

Modular construction can also be extended to other aspects of the drilling assembly, such as internal seals. For instance, the high-pressure seals used in conjunction with the APD Device and/or motor can be a hydrodynamic seal that provides a selected leak or flow rates. In one embodiment, the seal includes a concentrically arranged inner sleeve and outer sleeve. A gap between the inner sleeve and the outer sleeve permits a predetermined or specified amount of drilling fluid to leak through between the concentric sleeves. Different seal modules can provide different degrees of leak rates. The different seal modules can also be configured have different functional characteristics such as radial support.

Thus, it should be appreciated that for a given drilling environment, the appropriate configuration or re-configuration of one or more modules in the wellbore drilling system can enhance drilling efficiency and increase system life by reducing sub-optimal operation.

Examples of the more important features of the invention have been summarized (albeit rather broadly) in order that the detailed description thereof that follows may be better understood and in order that the contributions they represent to the art may be appreciated. There are, of course, additional features of the invention that will be described hereinafter and which will form the subject of the claims appended hereto.

BRIEF DESCRIPTION OF THE DRAWINGS

For detailed understanding of the present invention, reference should
5 be made to the following detailed description of the preferred embodiment,
taken in conjunction with the accompanying drawing:

Figure 1A is a schematic illustration of one embodiment of a system
using an active pressure differential device to manage pressure in a
predetermined wellbore location;

10 **Figure 1B** graphically illustrates the effect of an operating active
pressure differential device upon the pressure at a predetermined wellbore
location;

Figure 2 is a schematic elevation view of **Figure 1A** after the drill string
and the active pressure differential device have moved a certain distance in
15 the earth formation from the location shown in **Figure 1A**;

Figure 3 is a schematic elevation view of an alternative embodiment of
the wellbore system wherein the active pressure differential device is attached
to the wellbore inside;

Figures 4A-D are schematic illustrations of one embodiment of an
20 arrangement according to the present invention wherein a positive
displacement motor is coupled to a positive displacement pump (the APD
Device);

Figures 5A and 5B are schematic illustrations of one embodiment of
an arrangement according to the present invention wherein a turbine drive is

coupled to a centrifugal pump (the APD Device);

Figure 6A is a schematic illustration of an embodiment of an arrangement according to the present invention wherein an electric motor disposed on the outside of a drill string is coupled to an APD Device;

5 **Figure 6B** is a schematic illustration of an embodiment of an arrangement according to the present invention wherein an electric motor disposed within a drill string is coupled to an APD Device;

Figure 7 is a schematic illustration of an embodiment of an arrangement according to the present invention wherein the wellbore drilling
10 system includes at least one modular component; and

Figure 8 is a schematic illustration of an embodiment of a modular seal arrangement according to the present invention.

15 **DETAILED DESCRIPTION OF PREFERRED EMBODIMENTS**

Referring initially to **Figure 1A**, there is schematically illustrated a system for performing one or more operations related to the construction, logging, completion or work-over of a hydrocarbon producing well. In
20 particular, **Figure 1A** shows a schematic elevation view of one embodiment of a wellbore drilling system **100** for drilling wellbore **90** using conventional drilling fluid circulation. The drilling system **100** is a rig for land wells and includes a drilling platform **101**, which may be a drill ship or another suitable surface workstation such as a floating platform or a semi-submersible for

offshore wells. For offshore operations, additional known equipment such as a riser and subsea wellhead will typically be used. To drill a wellbore **90**, well control equipment **125** (also referred to as the wellhead equipment) is placed above the wellbore **90**. The wellhead equipment **125** includes a blow-out-
5 preventer stack **126** and a lubricator (not shown) with its associated flow control.

This system **100** further includes a well tool such as a drilling assembly or a bottomhole assembly ("BHA") **135** at the bottom of a suitable umbilical
10 such as drill string or tubing **121** (such terms will be used interchangeably). In a preferred embodiment, the BHA **135** includes a drill bit **130** adapted to disintegrate rock and earth. The bit can be rotated by a surface rotary drive or a motor using pressurized fluid (e.g., mud motor) or an electrically driven motor. The tubing **121** can be formed partially or fully of drill pipe, metal or
15 composite coiled tubing, liner, casing or other known members. Additionally, the tubing **121** can include data and power transmission carriers such fluid conduits, fiber optics, and metal conductors. Conventionally, the tubing **121** is placed at the drilling platform **101**. To drill the wellbore **90**, the BHA **135** is conveyed from the drilling platform **101** to the wellhead equipment **125** and
20 then inserted into the wellbore **90**. The tubing **121** is moved into and out of the wellbore **90** by a suitable tubing injection system.

During drilling, a drilling fluid from a surface mud system **22** is pumped under pressure down the tubing **121** (a "supply fluid"). The mud system **22**

includes a mud pit or supply source **26** and one or more pumps **28**. In one embodiment, the supply fluid operates a mud motor in the BHA **135**, which in turn rotates the drill bit **130**. The drill string **121** rotation can also be used to rotate the drill bit **130**, either in conjunction with or separately from the mud 5 motor. The drill bit **130** disintegrates the formation (rock) into cuttings **147**. The drilling fluid leaving the drill bit travels uphole through the annulus **194** between the drill string **121** and the wellbore wall or inside **196**, carrying the drill cuttings **147** therewith (a "return fluid"). The return fluid discharges into a separator (not shown) that separates the cuttings **147** and other solids from 10 the return fluid and discharges the clean fluid back into the mud pit **26**. As shown in **Figure 1A**, the clean mud is pumped through the tubing **121** while the mud with cuttings **147** returns to the surface via the annulus **194** up to the wellhead equipment **125**.

15 Once the well **90** has been drilled to a certain depth, casing **129** with a casing shoe **151** at the bottom is installed. The drilling is then continued to drill the well to a desired depth that will include one or more production sections, such as section **155**. The section below the casing shoe **151** may not be cased until it is desired to complete the well, which leaves the bottom 20 section of the well as an open hole, as shown by numeral **156**.

As noted above, the present invention provides a drilling system for controlling bottomhole pressure at a zone of interest designated by the numeral **155** and thereby the ECD effect on the wellbore. In one embodiment

of the present invention, to manage or control the pressure at the zone **155**, an active pressure differential device ("APD Device") **170** is fluidically coupled to return fluid downstream of the zone of interest **155**. The active pressure differential device is a device that is capable of creating a pressure differential 5 " ΔP " across the device. This controlled pressure drop reduces the pressure upstream of the APD Device **170** and particularly in zone **155**.

The system **100** also includes downhole devices that separately or cooperatively perform one or more functions such as controlling the flow rate 10 of the drilling fluid and controlling the flow paths of the drilling fluid. For example, the system **100** can include one or more flow-control devices that can stop the flow of the fluid in the drill string and/or the annulus **194**. **Figure 1A** shows an exemplary flow-control device **173** that includes a device **174** that can block the fluid flow within the drill string **121** and a device **175** that 15 blocks can block fluid flow through the annulus **194**. The device **173** can be activated when a particular condition occurs to insulate the well above and below the flow-control device **173**. For example, the flow-control device **173** may be activated to block fluid flow communication when drilling fluid circulation is stopped so as to isolate the sections above and below the 20 device **173**, thereby maintaining the wellbore below the device **173** at or substantially at the pressure condition prior to the stopping of the fluid circulation.

The flow-control devices **174**, **175** can also be configured to selectively

control the flow path of the drilling fluid. For example, the flow-control device **174** in the drill pipe **121** can be configured to direct some or all of the fluid in drill string **121** into the annulus **194**. Moreover, one or both of the flow-control devices **174**, **175** can be configured to bypass some or all of the return fluid 5 around the APD device **170**. Such an arrangement may be useful, for instance, to assist in lifting cuttings to the surface. The flow-control device **173** may include check-valves, packers and any other suitable device. Such devices may automatically activate upon the occurrence of a particular event or condition.

10

The system **100** also includes downhole devices for processing the cuttings (e.g., reduction of cutting size) and other debris flowing in the annulus **194**. For example, a comminution device **176** can be disposed in the annulus **194** upstream of the APD device **170** to reduce the size of entrained 15 cutting and other debris. The comminution device **176** can use known members such as blades, teeth, or rollers to crush, pulverize or otherwise disintegrate cuttings and debris entrained in the fluid flowing in the annulus **194**. The comminution device **176** can be operated by an electric motor, a hydraulic motor, by rotation of drill string or other suitable means. The 20 comminution device **176** can also be integrated into the APD device **170**. For instance, if a multi-stage turbine is used as the APD device **170**, then the stages adjacent the inlet to the turbine can be replaced with blades adapted to cut or shear particles before they pass through the blades of the remaining turbine stages.

Sensors S_{1-n} are strategically positioned throughout the system 100 to provide information or data relating to one or more selected parameters of interest (pressure, flow rate, temperature). In a preferred embodiment, the
5 downhole devices and sensors S_{1-n} communicate with a controller 180 via a telemetry system (not shown). Using data provided by the sensors S_{1-n} , the controller 180 maintains the wellbore pressure at zone 155 at a selected pressure or range of pressures. The controller 180 maintains the selected pressure by controlling the APD device 170 (e.g., adjusting amount of energy
10 added to the return fluid line) and/or the downhole devices (e.g., adjusting flow rate through a restriction such as a valve).

When configured for drilling operations, the sensors S_{1-n} provide measurements relating to a variety of drilling parameters, such as fluid
15 pressure, fluid flow rate, rotational speed of pumps and like devices, temperature, weight-on bit, rate of penetration, etc., drilling assembly or BHA parameters, such as vibration, stick slip, RPM, inclination, direction, BHA location, etc. and formation or formation evaluation parameters commonly referred to as measurement-while-drilling parameters such as resistivity,
20 acoustic, nuclear, NMR, etc. One preferred type of sensor is a pressure sensor for measuring pressure at one or more locations. Referring still to Fig. 1A, pressure sensor P_1 provides pressure data in the BHA, sensor P_2 provides pressure data in the annulus, pressure sensor P_3 in the supply fluid, and pressure sensor P_4 provides pressure data at the surface. Other

pressure sensors may be used to provide pressure data at any other desired place in the system **100**. Additionally, the system **100** includes fluid flow sensors such as sensor **V** that provides measurement of fluid flow at one or more places in the system.

5

Further, the status and condition of equipment as well as parameters relating to ambient conditions (e.g., pressure and other parameters listed above) in the system **100** can be monitored by sensors positioned throughout the system **100**: exemplary locations including at the surface (**S1**), at the APD 10 device **170** (**S2**), at the wellhead equipment **125** (**S3**), in the supply fluid (**S4**), along the tubing **121** (**S5**), at the well tool **135** (**S6**), in the return fluid upstream of the APD device **170** (**S7**), and in the return fluid downstream of the APD device **170** (**S8**). It should be understood that other locations may also be used for the sensors **S_{1-n}**.

15

The controller **180** for suitable for drilling operations preferably includes programs for maintaining the wellbore pressure at zone **155** at under-balance condition, at at-balance condition or at over-balanced condition. The controller **180** includes one or more processors that process signals from the 20 various sensors in the drilling assembly and also controls their operation. The data provided by these sensors **S_{1-n}** and control signals transmitted by the controller **180** to control downhole devices such as devices **173-176** are communicated by a suitable two-way telemetry system (not shown). A separate processor may be used for each sensor or device. Each sensor

may also have additional circuitry for its unique operations. The controller 180, which may be either downhole or at the surface, is used herein in the generic sense for simplicity and ease of understanding and not as a limitation because the use and operation of such controllers is known in the art. The controller 180 preferably contains one or more microprocessors or micro-controllers for processing signals and data and for performing control functions, solid state memory units for storing programmed instructions, models (which may be interactive models) and data, and other necessary control circuits. The microprocessors control the operations of the various sensors, provide communication among the downhole sensors and provide two-way data and signal communication between the drilling assembly 30, downhole devices such as devices 173-175 and the surface equipment via the two-way telemetry. In other embodiments, the controller 180 can be a hydro-mechanical device that incorporates known mechanisms (valves, biased members, linkages cooperating to actuate tools under, for example, preset conditions).

For convenience, a single controller 180 is shown. It should be understood, however, that a plurality of controllers 180 can also be used. For example, a downhole controller can be used to collect, process and transmit data to a surface controller, which further processes the data and transmits appropriate control signals downhole. Other variations for dividing data processing tasks and generating control signals can also be used.

In general, however, during operation, the controller **180** receives the information regarding a parameter of interest and adjusts one or more downhole devices and/or APD device **170** to provide the desired pressure or range or pressure in the vicinity of the zone of interest **155**. For example, the 5 controller **180** can receive pressure information from one or more of the sensors (**S₁-S_n**) in the system **100**. The controller **180** may control the APD Device **170** in response to one or more of: pressure, fluid flow, a formation characteristic, a wellbore characteristic and a fluid characteristic, a surface measured parameter or a parameter measured in the drill string. The 10 controller **180** determines the ECD and adjusts the energy input to the APD device **170** to maintain the ECD at a desired or predetermined value or within a desired or predetermined range. The wellbore system **100** thus provides a closed loop system for controlling the ECD in response to one or more parameters of interest during drilling of a wellbore. This system is relatively 15 simple and efficient and can be incorporated into new or existing drilling systems and readily adapted to support other well construction, completion, and work-over activities.

In the embodiment shown in **Figure 1A**, the APD Device **170** is shown 20 as a turbine attached to the drill string **121** that operates within the annulus **194**. Other embodiments, described in further detail below can include centrifugal pumps, positive displacement pump, jet pumps and other like devices. During drilling, the APD Device **170** moves in the wellbore **90** along with the drill string **121**. The return fluid can flow through the APD Device **170**

whether or not the turbine is operating. However, the APD Device **170**, when operated creates a differential pressure thereacross.

As described above, the system **100** in one embodiment includes a
5 controller **180** that includes a memory and peripherals **184** for controlling the operation of the APD Device **170**, the devices **173-176**, and/or the bottomhole assembly **135**. In **Figure 1A**, the controller **180** is shown placed at the surface. It, however, may be located adjacent the APD Device **170**, in the BHA **135** or at any other suitable location. The controller **180** controls the
10 APD Device to create a desired amount of ΔP across the device, which alters the bottomhole pressure accordingly. Alternatively, the controller **180** may be programmed to activate the flow-control device **173** (or other downhole devices) according to programmed instructions or upon the occurrence of a particular condition. Thus, the controller **180** can control the APD Device in
15 response to sensor data regarding a parameter of interest, according to programmed instructions provided to said APD Device, or in response to instructions provided to said APD Device from a remote location. The controller **180** can, thus, operate autonomously or interactively.

20 During drilling, the controller **180** controls the operation of the APD Device to create a certain pressure differential across the device so as to alter the pressure on the formation or the bottomhole pressure. The controller **180** may be programmed to maintain the wellbore pressure at a value or range of values that provide an under-balance condition, an at-balance condition or an

over-balanced condition. In one embodiment, the differential pressure may be altered by altering the speed of the APD Device. For instance, the bottomhole pressure may be maintained at a preselected value or within a selected range relative to a parameter of interest such as the formation
5 pressure. The controller 180 may receive signals from one or more sensors in the system 100 and in response thereto control the operation of the APD Device to create the desired pressure differential. The controller 180 may contain pre-programmed instructions and autonomously control the APD Device or respond to signals received from another device that may be
10 remotely located from the APD Device.

Figure 1B graphically illustrates the ECD control provided by the above-described embodiment of the present invention and references Figure 1A for convenience. Figure 1A shows the APD device 170 at a depth D1 and
15 a representative location in the wellbore in the vicinity of the well tool 30 at a lower depth D2. Figure 1B provides a depth versus pressure graph having a first curve C1 representative of a pressure gradient before operation of the system 100 and a second curve C2 representative of a pressure gradient during operation of the system 100. Curve C3 represents a theoretical curve
20 wherein the ECD condition is not present; *i.e.*, when the well is static and not circulating and is free of drill cuttings. It will be seen that a target or selected pressure at depth D2 under curve C3 cannot be met with curve C1. Advantageously, the system 100 reduces the hydrostatic pressure at depth D1 and thus shifts the pressure gradient as shown by curve C3, which can

provide the desired predetermined pressure at depth **D2**. In most instances, this shift is roughly the pressure drop provided by the APD device **170**.

5 **Figure 2** shows the drill string after it has moved the distance "d" shown by $t_1 - t_2$. Since the APD Device **170** is attached to the drill string **121**, the APD Device **170** also is shown moved by the distance d.

As noted earlier and shown in **Figure 2**, an APD Device **170a** may be
10 attached to the wellbore in a manner that will allow the drill string **121** to move while the APD Device **170a** remains at a fixed location. **Figure 3** shows an embodiment wherein the APD Device is attached to the wellbore inside and is operated by a suitable device **172a**. Thus, the APD device can be attached to a location stationary relative to said drill string such as a casing, a liner, the
15 wellbore annulus, a riser, or other suitable wellbore equipment. The APD Device **170a** is preferably installed so that it is in a cased upper section **129**. The device **170a** is controlled in the manner described with respect to the device **170** (**Fig 1A**).

20 Referring now to **Figures 4A-D**, there is schematically illustrated one arrangement wherein a positive displacement motor/drive **200** is coupled to a moineau-type pump **220** via a shaft assembly **240**. The motor **200** is connected to an upper string section **260** through which drilling fluid is pumped from a surface location. The pump **220** is connected to a lower drill

string section **262** on which the bottomhole assembly (not shown) is attached at an end thereof. The motor **200** includes a rotor **202** and a stator **204**. Similarly, the pump **220** includes a rotor **222** and a stator **224**. The design of moineau-type pumps and motors are known to one skilled in the art and will not be discussed in further detail.

The shaft assembly **240** transmits the power generated by the motor **200** to the pump **220**. One preferred shaft assembly **240** includes a motor flex shaft **242** connected to the motor rotor **202**, a pump flex shaft **244** connected to the pump rotor **224**, and a coupling shaft **246** for joining the first and second shafts **242** and **244**. In one arrangement, a high-pressure seal **248** is disposed about the coupling shaft **246**. As is known, the rotors for moineau-type motors/pump are subject to eccentric motion during rotation. Accordingly, the coupling shaft **246** is preferably articulated or formed sufficiently flexible to absorb this eccentric motion. Alternately or in combination, the shafts **242**, **244** can be configured to flex to accommodate eccentric motion. Radial and axial forces can be borne by bearings **250** positioned along the shaft assembly **240**. In a preferred embodiment, the seal **248** is configured to bear either or both of radial and axial (thrust) forces.

In certain arrangements, a speed or torque converter **252** can be used to convert speed/torque of the motor **200** to a second speed/torque for the pump **220**. By speed/torque converter it is meant known devices such as variable or fixed ratio mechanical gearboxes, hydrostatic torque converters, and hydrodynamic converters. It should be understood that any number of

arrangements and devices can be used to transfer power, speed, or torque from the motor **200** to the pump **220**. For example, the shaft assembly **240** can utilize a single shaft instead of multiple shafts.

5 As described earlier, a comminution device can be used to process entrained cutting in the return fluid before it enters the pump **200**. Such a comminution device (**Figure 1A**) can be coupled to the drive **200** or pump **220** and operated thereby. For instance, one such comminution device or cutting mill **270** can include a shaft **272** coupled to the pump rotor **224**. The
10 shaft **272** can include a conical head or hammer element **274** mounted thereon. During rotation, the eccentric motion of the pump rotor **224** will cause a corresponding radial motion of the shaft head **274**. This radial motion can be used to resize the cuttings between the rotor and a comminution device housing **276**.

15

The **Figures 4A-D** arrangement also includes a supply flow path **290** to carry supply fluid from the device **200** to the lower drill string section **262** and a return flow path **292** to channel return fluid from the casing interior or annulus into and out of the pump **220**. The high pressure seal **248** is
20 interposed between the flow paths **290** and **292** to prevent fluid leaks, particularly from the high pressure fluid in the supply flow path **290** into the return flow path **292**. The seal **248** can be a high-pressure seal, a hydrodynamic seal or other suitable seal and formed of rubber, an elastomer, metal or composite.

Additionally, bypass devices are provided to allow fluid circulation during tripping of the downhole devices of the system **100 (Fig. 1A)**, to control the operating set points of the motor **200** and pump **220**, and to provide 5 safety pressure relief along either or both of the supply flow path **290** and the return flow path **292**. Exemplary bypass devices include a circulation bypass **300**, motor bypass **310**, and a pump bypass **320**.

The circulation bypass **300** selectively diverts supply fluid into the 10 annulus **194 (Fig. 1A)** or casing **C** interior. The circulation bypass **300** is interposed generally between the upper drill string section **260** and the motor **200**. One preferred circulation bypass **300** includes a biased valve member **302** that opens when the flow-rate drops below a predetermined valve. When the valve **302** is open, the supply fluid flows along a channel **304** and exits at 15 ports **306**. More generally, the circulation bypass can be configured to actuate upon receiving an actuating signal and/or detecting a predetermined value or range of values relating to a parameter of interest (e.g., flow rate or pressure of supply fluid or operating parameter of the bottomhole assembly). The circulation bypass **300** can be used to facilitate drilling operations and to 20 selective increase the pressure/flow rate of the return fluid.

The motor bypass **310** selectively channels conveys fluid around the motor **200**. The motor bypass **310** includes a valve **312** and a passage **314** formed through the motor rotor **202**. A joint **316** connecting the motor rotor

202 to the first shaft **242** includes suitable passages (not shown) that allow the supply fluid to exit the rotor passage **314** and enter the supply flow path **290**. Likewise, a pump bypass **320** selectively conveys fluid around the pump **220**. The pump bypass includes a valve and a passage formed 5 through the pump rotor **222** or housing. The pump bypass **320** can also be configured to function as a particle bypass line for the APD device. For example, the pump bypass can be adapted with known elements such as screens or filters to selectively convey cuttings or particles entrained in the return fluid that are greater than a predetermined size around the APD 10 device. Alternatively, a separate particle bypass can be used in addition to the pump bypass for such a function. Alternately, a valve (not shown) in a pump housing **225** can divert fluid to a conduit parallel to the pump **220**. Such a valve can be configured to open when the flow rate drops below a predetermined value. Further, the bypass device can be a design internal 15 leakage in the pump. That is, the operating point of the pump **220** can be controlled by providing a preset or variable amount of fluid leakage in the pump **220**. Additionally, pressure valves can be positioned in the pump **220** to discharge fluid in the event an overpressure condition or other predetermined condition is detected.

20

Additionally, an annular seal **299** in certain embodiments can be disposed around the APD device to direct the return fluid to flow into the pump **220** (or more generally, the APD device) and to allow a pressure differential across the pump **220**. The seal **299** can be a solid or pliant ring

member, an expandable packer type element that expands/contracts upon receiving a command signal, or other member that substantially prevents the return fluid from flowing between the pump **220** (or more generally, the APD device) and the casing or wellbore wall. In certain applications, the clearance 5 between the APD device and adjacent wall (either casing or wellbore) may be sufficiently small as to not require an annular seal.

During operation, the motor **200** and pump **220** are positioned in a well bore location such as in a casing **C**. Drilling fluid (the supply fluid) flowing 10 through the upper drill string section **260** enters the motor **200** and causes the rotor **202** to rotate. This rotation is transferred to the pump rotor **222** by the shaft assembly **240**. As is known, the respective lobe profiles, size and configuration of the motor **200** and the pump **220** can be varied to provide a selected speed or torque curve at given flow-rates. Upon exiting the motor 15 **200**, the supply fluid flows through the supply flow path **290** to the lower drill string section **262**, and ultimately the bottomhole assembly (not shown). The return fluid flows up through the wellbore annulus (not shown) and casing **C** and enters the cutting mill **270** via a inlet **293** for the return flow path **292**. The flow goes through the cutting mill **270** and enters the pump **220**. In this 20 embodiment, the controller **180** (**Fig. 1A**) can be programmed to control the speed of the motor **200** and thus the operation of the pump **220** (the APD Device in this instance).

It should be understood that the above-described arrangement is

merely one exemplary use of positive displacement motors and pumps. For example, while the positive displacement motor and pump are shown in structurally in series in **Figures 4A-D**, a suitable arrangement can also have a positive displacement motor and pump in parallel. For example, the motor
5 can be concentrically disposed in a pump.

Referring now to **Figures 5A-B**, there is schematically illustrated one arrangement wherein a turbine drive **350** is coupled to a centrifugal-type pump **370** via a shaft assembly **390**. The turbine **350** includes stationary and
10 rotating blades **354** and radial bearings **402**. The centrifugal-type pump **370** includes a housing **372** and multiple impeller stages **374**. The design of turbines and centrifugal pumps are known to one skilled in the art and will not be discussed in further detail.

15 The shaft assembly **390** transmits the power generated by the turbine **350** to the centrifugal pump **370**. One preferred shaft assembly **350** includes a turbine shaft **392** connected to the turbine blade assembly **354**, a pump shaft **394** connected to the pump impeller stages **374**, and a coupling **396** for joining the turbine and pump shafts **392** and **394**.

20

The **Figure 5A-B** arrangement also includes a supply flow path **410** for channeling supply fluid shown by arrows designated **416** and a return flow path **418** to channel return fluid shown by arrows designated **424**. The supply flow path **410** includes an inlet **412** directing supply fluid into the turbine **350**

and an axial passage **413** that conveys the supply fluid exiting the turbine **350** to an outlet **414**. The return flow path **418** includes an inlet **420** that directs return fluid into the centrifugal pump **370** and an outlet **422** that channels the return fluid into the casing **C** interior or wellbore annulus. A high pressure seal **400** is interposed between the flow paths **410** and **418** to reduce fluid leaks, particularly from the high pressure fluid in the supply flow path **410** into the return flow path **418**. A small leakage rate is desired to cool and lubricate the axial and radial bearings. Additionally, a bypass **426** can be provided to divert supply fluid from the turbine **350**. Moreover, radial and axial forces can be borne by bearing assemblies **402** positioned along the shaft assembly **390**. Preferably a comminution device **373** is provided to reduce particle size entering the centrifugal pump **370**. In a preferred embodiment, one of the impeller stages is modified with shearing blades or elements that shear entrained particles to reduce their size. In certain arrangements, a speed or torque converter **406** can be used to convert a first speed/torque of the motor **350** to a second speed/torque for the centrifugal pump **370**. It should be understood that any number of arrangements and devices can be used to transfer power, speed, or torque from the turbine **350** to the pump **370**. For example, the shaft assembly **390** can utilize a single shaft instead of multiple shafts.

It should be appreciated that a positive displacement pump need not be matched with only a positive displacement motor, or a centrifugal pump with only a turbine. In certain applications, operational speed or space

considerations may lend itself to an arrangement wherein a positive displacement drive can effectively energize a centrifugal pump or a turbine drive energize a positive displacement pump. It should also be appreciated that the present invention is not limited to the above-described arrangements.

5 For example, a positive displacement motor can drive an intermediate device such as an electric motor or hydraulic motor provided with an encapsulated clean hydraulic reservoir. In such an arrangement, the hydraulic motor (or produced electric power) drives the pump. These arrangements can eliminate the leak paths between the high-pressure supply fluid and the return fluid and
10 therefore eliminates the need for high-pressure seals. Alternatively, a jet pump can be used. In an exemplary arrangement, the supply fluid is divided into two streams. The first stream is directed to the BHA. The second stream is accelerated by a nozzle and discharged with high velocity into the annulus, thereby effecting a reduction in annular pressure. Pumps
15 incorporating one or more pistons, such as hammer pumps, may also be suitable for certain applications.

Referring now to **Figure 6A**, there is schematically illustrated one arrangement wherein an electrically driven pump assembly **500** includes a
20 motor **510** that is at least partially positioned external to a drill string **502**. In a conventional manner, the motor **510** is coupled to a pump **520** via a shaft assembly **530**. A supply flow path **504** conveys supply fluid designated with arrow **505** and a return flow path **506** conveys return fluid designated with arrow **507**. As can be seen, the **Figure 6A** arrangement does not include

leak paths through which the high-pressure supply fluid **505** can invade the return flow path **506**. Thus, there is no need for high pressures seals.

In one embodiment, the motor **510** includes a rotor **512**, a stator **514**,
5 and a rotating seal **516** that protects the coils **512** and stator **514** from drilling fluid and cuttings. In one embodiment, the stator **514** is fixed on the outside of the drill string **502**. The coils of the rotor **512** and stator **514** are encapsulated in a material or housing that prevents damage from contact with wellbore fluids. Preferably, the motor **510** interiors are filled with a clean hydraulic
10 fluid. In another embodiment not shown, the rotor is positioned within the flow of the return fluid, thereby eliminating the rotating seal. In such an arrangement, the stator can be protected with a tube filled with clean hydraulic fluid for pressure compensation.

15 Referring now to **Figure 6B**, there is schematically illustrated one arrangement wherein an electrically driven pump **550** includes a motor **570** that is at least partially formed integral with a drill string **552**. In a conventional manner, the motor **570** is coupled to a pump **590** via a shaft assembly **580**. A supply flow path **554** conveys supply fluid designated with
20 arrow **556** and a return flow path **558** conveys return fluid designated with arrow **560**. As can be seen, the **Figure 6B** arrangement does not include leak paths through which the high-pressure supply fluid **556** can invade the return flow path **558**. Thus, there is no need for high pressures seals.

It should be appreciated that an electrical drive provides a relatively simple method for controlling the APD Device. For instance, varying the speed of the electrical motor will directly control the speed of the rotor in the APD device, and thus the pressure differential across the APD Device.

5 Further, in either of the **Figure 6A or 6B** arrangements, the pump **520** and **590** can be any suitable pump, and is preferably a multi-stage centrifugal-type pump. Moreover, positive displacement type pumps such a screw or gear type or moineau-type pumps may also be adequate for many applications. For example, the pump configuration may be single stage or multi-stage and

10 utilize radial flow, axial flow, or mixed flow. Additionally, as described earlier, a comminution device positioned downhole of the pumps **520** and **590** can be used to reduce the size of particles entrained in the return fluid.

It will be appreciated that many variations to the above-described

15 embodiments are possible. For example, a clutch element can be added to the shaft assembly connecting the drive to the pump to selectively couple and uncouple the drive and pump. Further, in certain applications, it may be advantages to utilize a non-mechanical connection between the drive and the pump. For instance, a magnetic clutch can be used to engage the drive and

20 the pump. In such an arrangement, the supply fluid and drive and the return fluid and pump can remain separated. The speed/torque can be transferred by a magnetic connection that couples the drive and pump elements, which are separated by a tubular element (e.g., drill string). Additionally, while certain elements have been discussed with respect to one or more particular

embodiments, it should be understood that the present invention is not limited to any such particular combinations. For example, elements such as shaft assemblies, bypasses, comminution devices and annular seals discussed in the context of positive displacement drives can be readily used with electric

5 drive arrangements. Other embodiments within the scope of the present invention that are not shown include a centrifugal pump that is attached to the drill string. The pump can include a multi-stage impeller and can be driven by a hydraulic power unit, such as a motor. This motor may be operated by the drilling fluid or by any other suitable manner. Still another embodiment not

10 shown includes an APD Device that is fixed to the drill string, which is operated by the drill string rotation. In this embodiment, a number of impellers are attached to the drill string. The rotation of the drill string rotates the impeller that creates a differential pressure across the device.

In certain embodiments of the present invention, one or more of the

15 components described in reference to **Figs. 1A-6B** utilize a modular construction. In one aspect, the term modular construction implies a standardized structural configuration having generic or universal coupling interfaces that enables a component to be interchangeable within the wellbore drilling assembly. Thus, for instance, if a component fails or is in

20 need of maintenance, a replacement component is inserted in its place within the drilling assembly. In another aspect, this term implies a component available as a plurality of modules. Each module has a standardized housing for interchangeability while also being functionally or operationally distinct from one another (*e.g.*, each module has different operating set point or

operating range and/or different performance characteristics). Thus, as drilling dynamics change, the component module having the appropriate operating or performance characteristics for obtain optimal drilling efficiency is inserted into the wellbore drilling assembly. Still other aspects and
5 advantages of the modular construction will become apparent in the following description.

As is known, a number of factors can affect the overall cost of drilling a wellbore and the quality of the wellbore drilled. Exemplary factors include the lithology of the formation to be drilled, the complexity of the wellbore
10 trajectory, the geographical location (e.g., land-based or offshore), the wellbore environment (e.g., pressure, temperature, etc.), and the operating characteristics and limits of the drilling system.

Conventionally, a wellbore drilling assembly having a substantially fixed or static configuration is used throughout the drilling activity. However, the
15 lithology of a formation can vary from a relatively soft earth that is easy to displace to earth containing hard rock that requires more energy to disintegrate. As is known, adjustments to the drilling parameters to account for changes in lithology can alter the stresses and loadings on the wellbore drilling system as well as impact its efficiency. Also, it is now common for the
20 planned trajectory of a wellbore to deviate from a vertical or plumb line. For instance, the wellbore can include deviated sections, short-radius sections, and horizontal sections in addition to vertical sections. Each such section can impose unique loadings on the wellbore drilling system. One method for accommodating changes in drilling dynamics caused by these and other

factors is to adjust certain drilling operating parameters (e.g., weight-on-bit, drilling fluid flow rate, drill bit rotation speed, etc.). Such adjustments, however, may lead to sub-optimal drilling (e.g., reduced rate of penetration) or increased wear on the wellbore drilling assembly components. Another

5 method of dealing with changing drilling dynamics is to include sophisticated control devices (e.g., flow restriction devices and bypass valves) within the wellbore drilling assembly that control the operation of one or more of its constituent components. The use of such control devices can increase the complexity of the wellbore drilling assembly and increase its overall cost.

10 Referring now to **Fig. 7**, there is schematically shown a section of a wellbore drilling assembly **600** having a modular APD Device **602** (e.g., a pump), a modular motor **604** driving the modular APD Device **602**, a modular comminution device **606**, and a modular annular seal **608**. The modular construction of these components provides flexibility in assembling a wellbore

15 drilling system **600** that operates optimally in each phase of drilling operations and facilitates the transportation, maintenance and repair of the wellbore drilling system. As will be described below, any one of these above-mentioned modular components can be formed as a plurality of interchangeable units. Each interchangeable unit can have a specified and

20 different operating characteristic. Thus, the drilling assembly **600** can be deployed in multiple configurations, each of which has a selected behavior during operation and a selected response to a given drilling condition.

In one embodiment, the pump **602** is made available in a plurality of interchangeable modular units. Each modular pump **602** is configured to

operate a different set points or ranges of set points (e.g., rotational speed, flow rates, pressure differential, etc.). One or more of these modular units can also be fitted with devices (e.g., bypass valves and pressure relief valves) that have different set points. Thus, in instances where a particular drilling environment or operating condition causes the modular pump **602** to operate sub-optimally, that modular pump **602** can be changed out with a modular pump having operating characteristics more suited to the particular conditions encountered. For example, the pump module **602** may be changed out to increase or decrease the pressure differential produced in the return fluid **612**. The modular construction can also provide flexibility in designing the drilling assembly. For example, instead of using a single pump **602** to generate a given pressure differential, a plurality of pump **602** modules can be arranged in a serial fashion to generate the given pressure differential across multiple stages. It should be appreciated that pressure differential is merely one operating parameter than can be varied between successive pump modules **602**. The configurations of the pump **602** modules can also be designed to account for different compositions of cuttings (e.g., rock size or make-up) in the return fluid **612**, the density of the return fluid **612**, drilling fluid flow rates, etc.

The motor **604** can also be configured as interchangeable units having specified set point or ranges of set points (e.g., operating RPM and/or torque) and can include control devices having different operating set points. The selection of the appropriate motor module **604** can be based, for example, on the operating requirements of the pump **602**, the characteristics of the drilling

fluid (e.g., flow rate or pressure), and the wellbore environment (e.g., loadings, temperature, etc.).

Also, in certain embodiments, the pump 602 and motor 604 can be formed as an integral modular unit that can be readily inserted or removed from a wellbore drilling assembly 600. Thus, each integral pump and motor module can be adapted to provide distinct operating characteristics.

As discussed earlier, the comminution device 606 processes entrained cuttings before they enter the pump 602. Like the modular motor 604 and pump 602, the comminution device 606 can be made as a plurality of modules. Each module can be configured for optimal performance under a different operating parameter such as a selected flow rate, cutting composition, rotational speed of the driving mechanism, volume of cuttings in the return fluid 612, etc. Additionally, the modular comminution device 606 can be configured to produce different sizes of reduced cuttings. Thus, advantageously, the modular comminution device 606 can be changed-out to match the operating requirements of the pump 602 (e.g., maximum particle size in the return fluid 612 flowing through the pump 602) and/or other devices such as passage ways, valves, and other fluid conduits. It should be noted that the comminution device modules 606 need not be structurally identical. For instance, one module can be configured as a single stage device having one chamber wherein particles are crushed or otherwise reduced in size. Still another module can include a multiple-stage device having multiple chambers in which the particles are successively reduced in size. Nor do the modules need to utilize the same action for reducing particle

size. For instance, one module may use a crushing action whereas another module may use a shearing action and still another module utilizes a chemical agent to reduce particle size. Of course, in certain applications, the comminution device **606** can be omitted entirely.

5 As described earlier, the annular seal **608** selectively blocks flow along the annulus **616** formed between the wellbore drilling assembly **600** and wellbore wall **618** to direct the return fluid **612** into the comminution device **606** (or pump **602** module). As is known, the wellbore drilling assembly **600** can be deployed in wellbores having various diameters. Accordingly, the
10 annular seal **608** can be formed as a plurality of modules, each of which is suited for a specified wellbore diameter or range of wellbore diameters. The annular seal modules **608** can also be formed to handle different wellbore pressures, wellbore fluid chemistry, etc.

Additionally, features such as valves or safety devices associated with
15 the wellbore drilling system **600** can also be made modular to readily accommodate expected changes in the loadings and operating parameters of the wellbore drilling system **600**. Referring now to **Fig. 8**, there is shown an embodiment of a high-pressure seal **630** that, in one embodiment, is adapted for modular construction. The seal **630** is used in conjunction with a motor
20 **604** and pump **602** and is adapted to prevent the drilling fluid flowing between the stator and rotor of the motor **604** from leaking excessively into a relatively lower pressure region. That is, the seal **630** has a pre-determined leak rate that can be based on one or more operating conditions (discussed below).

In one embodiment, the seal **630** is a hydrodynamic seal that includes

a concentrically arranged inner sleeve **632** and outer sleeve **634**. The inner sleeve **632** is fixed on a shaft assembly **636** and the outer sleeve **634** is fixed to a housing **638**. A gap **640** between the inner sleeve **632** and the outer sleeve **634** is sized to permit a predetermined or specified amount of drilling fluid to leak through between the concentric sleeves **632** and **634**. Because the leak rate adversely affects the pressure differential available to drive the motor, one factor in determining the permissible leak rate is amount of pressure and flow rate losses that can be tolerated from a motor efficiency standpoint. Other factors include the amount of fluid needed to cool and lubricate bearings such as axial bearings **642**. Because acceptable leak rates can vary depending on the particular drilling conditions, one parameter or operating set point that can be different for the various modules of the seal **630** is leak rates.

Still other parameters or operating conditions can be made different for the various modules of the seal **630**. For instance, in the embodiment shown in **Fig. 8**, the seal **630** is also configured to operate as a radial bearing for providing lateral stability for the motor **604** (**Fig. 7**). Thus, the modules of the seal **630** can have distinct and different degrees of lateral support. Moreover, although two seals **630** are shown in the **Fig. 8** embodiment, other embodiments can use one seal or three or more seal elements.

In one embodiment, the inner and outer sleeves **632**, **634** include surfaces adapted to withstand the abrasive operating environment. During operation, the relative rotation between the inner and outer sleeves **602**, **604** can generate mechanical friction. Moreover, the high velocity of the drilling

fluid flowing through the gap **640** can cause wear. Accordingly, surfaces expected to encounter wear from either or both of these sources are hardened. For instance, the outer sleeve can be coated with a relatively hard material (e.g., tungsten carbide) and the inner sleeve can include hardened 5 inserts (e.g., tungsten carbide inserts). Still other treatments (e.g., carburizing, nitriding, etc.) can also be used in certain applications. The sleeves **632,634** can be made modular in form with separate modules. Each high-pressure seal module can be formed to have a different operational characteristics such as leak rate and wear hardness. The modules can also 10 be configured to provide different degrees of radial support. It should be understood, however, that the advantages of the described seal can also be realized in embodiments that do not utilize a modular construction.

In one embodiment, the housings or enclosures of the above-described components utilize a standardized interface. For example, the 15 housing of the components are provided standardized threads on one or more of the opposing ends. Also, the shafts or other members extending between the motor **604** and the pump **602** include complementary male and female connections (not shown). In other embodiments, devices such as flat planes, splines and tongue-and-groove arrangements can also be used. 20 Moreover, a coupling or adapter can be used to join together modules in lieu of (or in addition to) the modules being directly matable with one another.

The operating characteristics, set points and parameters described above are only some of the features that can be varied among the modules of a given component. For instance, the modules can be made to have varying

weights, lengths and diameters. The module enclosures and internals can use different materials to have varying resistance to the wellbore environment (wellbore fluids, chemical agents, etc.). Thus, it should be appreciated that in one aspect, what has been described is a wellbore drilling assembly formed

5 of at least one modular component. In one embodiment, the modular and interchangeable component includes a plurality of units, each of which is configured to have a specified operating set points, operating ranges, component dimensions, component weight, and component response to system operating parameters (e.g., flow rates, weight-on-bit, etc.). The

10 modules can have individualized responses to specified wellbore environment or conditions (e.g., stresses, corrosive agents, vibration, etc.). In certain embodiments, the joint arrangement for the modular component includes complementary male and female couplings for connecting features such as shafts and threads on one or both ends of the housing or enclosure.

15 A number of methodologies may be employed to advantageously apply the above teachings. In one illustrative method, one or more components making up a modular wellbore tool are selected for modular construction. One basis for this selection may be that a certain component may require frequent change-outs (e.g., for maintenance or repair). Another basis may be

20 that the operating capacity or range of a particular component can be extended by use of a modular design. As a first step, the selected components are constructed as modules (e.g., a drive module, a pump module, a comminution device module, annular seal modules, and a high-pressure seal module). A particular component may have a single modular

configuration (*i.e.*, each module having the same operating characteristic) or a plurality of modular configurations (*i.e.*, each module having a different operating capacity). In the next step, the individual component modules are assembled as tool sub-modules. For example, a drive module and pump

5 module can be assembled into a first tool sub-module and a comminution device module and annular seal module can be assembled into a second tool module. Much like the individual component modules, the tool sub-modules can each have a specified operating set point, range, characteristic and/or response. Furthermore, the tool sub-modules can be formed to address

10 other factors such as ease of transportation, handling and storage. That is, the tool sub-modules can be constructed to not exceed a particular weight or length so that they may be more easily transported and deployed. Other components such as high-pressure seal modules and modular valve modules can be constructed to be inserted into these or other tool sub-assembly.

15 Finally, the tool sub modules are coupled using a suitable coupling to form a modular tool. It should be appreciated that the operating characteristics of the modular tool can be adjusted by interchanging individual modules (*e.g.*, the pump module) or by interchanging tool sub-modules. Thus, in one process of construction, a modular tool for controlling wellbore pressure is

20 assembled in three steps. First, individual components having specified or discrete functions are formed as modular units. Second, these modular units are formed into tool sub-modules. And third, the tool sub-modules are assembled into the modular tool. It should be appreciated that the modular construction not only enhances the overall operating capacity of the modular

tool, but simplifies assembly, dis-assembly, repair, maintenance, handling, shipment and storage.

While the foregoing disclosure is directed to the preferred embodiments of the invention, various modifications will be apparent to those skilled in the art. It is intended that all variations within the scope and spirit of the appended claims be embraced by the foregoing disclosure.

WHAT IS CLAIMED IS:

- 1 1. A drilling system for drilling a wellbore, comprising
- 2 (a) a drill string having a drill bit at an end thereof;
- 3 (b) a source supplying drilling fluid under pressure into the drill string (a
- 4 "supply fluid"), the drilling fluid returning uphole via an annulus around the drill
- 5 string (a "return fluid");
- 6 (c) a modular tool in communication with the return fluid for reducing
- 7 pressure in the wellbore downhole of the modular tool, said modular tool having
- 8 at least one interchangeable modular unit;
- 9 (d) an active pressure differential device ("APD Device") associated
- 10 with the modular tool to create a pressure drop across said APD Device to
- 11 reduce ; and
- 12 (e) a drive assembly coupled to said APD Device for energizing said
- 13 APD Device.

- 1 2. The system according to claim (1) wherein said modular unit is provided
- 2 as a plurality of modular units, each of which are interchangeable with the other
- 3 and each of which has a substantially different value for a selected operating
- 4 parameter.

- 1 3. The system according to claim (1) wherein said APD Device is said

2 modular unit.

1 4. The system according to claim (3) further comprising a plurality of said
2 modular units, each of said modular units being configured to have a
3 substantially different value for a selected operating parameter.

1 5. The system according to claim (4) wherein said selected operating
2 parameter includes (i) pressure differential in the return fluid; (ii) rotation speed;
3 (iii) flow rate; and (iv) torque.

1 6. The system according to claim (1) wherein said drive assembly is said
2 modular unit.

1 7. The system according to claim (6) further comprising a plurality of said
2 modular units, each of said modular units being configured to have a
3 substantially different value for a selected operating parameter.

1 8. The system according to claim (7) wherein said selected operating
2 parameter is one of (i) differential pressure of the supply fluid; (ii) rotation speed;
3 (iii) flow rate; and (iv) torque.

1 9. The system according to claim (1) further comprising a comminution

2 device for reducing the size of particles entrained in the return fluid, said
3 comminution device being said modular unit.

1 10. The system according to claim (1) further comprising a high-pressure seal
2 for controlling the leaking of pressurized drilling fluid from said modular tool, said
3 high-pressure seal being said modular unit.

1 11. The system according to claim (1) further comprising an annular seal for
2 directing return fluid into said modular tool, said annular seal being said modular
3 unit.

1 12. A drilling system for drilling a wellbore, comprising
2 (a) a drill string having a drill bit at an end thereof;
3 (b) a source of drilling fluid supplying drilling fluid under pressure into
4 the drill string (a "supply fluid"), the drilling fluid returning uphole via an annulus
5 around the drill string (a "return fluid");
6 (c) an active pressure differential device ("APD Device") associated
7 with the return fluid to create a pressure drop across said APD Device to reduce
8 pressure in the wellbore downhole of the APD Device;
9 (d) a drive assembly coupled to said APD Device for energizing said
10 APD Device; and
11 (e) a high-pressure seal associated with said drive assembly, said seal

12 configure to provide a controlled leakage of pressurized drilling fluid out of said
13 drive assembly.

1 13. The drilling system according to claim (12) wherein said high-pressure
2 seal is configured to operate as a radial bearing for providing lateral stability a
3 shaft associated with said drive assembly.

1 14. The drilling system according to claim (12) wherein said high-pressure
2 seal comprises a plurality of seal elements.

1 15. The drilling system according to claim (12) wherein said high-pressure
2 seal is configured to provide a leak rate of fluid for cooling and lubricating a
3 bearing.

1 16. The drilling system according to claim (12) wherein said high-pressure
2 seal comprises a concentrically arranged inner sleeve and outer sleeve, said
3 inner sleeve being fixed on a shaft assembly associated with the drive assembly
4 and said outer sleeve being fixed to a housing associated with the drive
5 assembly.

1 17. The drilling system according to claim (12) wherein said high-pressure
2 seal includes one of (i) a hardened surface, and (ii) a hardened insert to reduce

3 frictional wear.

1 18. The drilling system according to claim (12) wherein said high-pressure
2 seal is formed as a modular unit.

1 19. A method of constructing a tool for reducing pressure in the wellbore
2 downhole of the modular tool, comprising:

3 (a) providing a plurality of modular units, said modular units being
4 selected from a group consisting of: (i) an active pressure differential device
5 module (APD device module) for creating a pressure differential in a fluid
6 returning from a drill bit; (ii) a drive module for energizing the APD Device
7 module; (iii) a comminution device module for reducing the size of cutting in the
8 wellbore; (iv) an annular seal module for directing fluid into the APD Device
9 module; and (v) a high-pressure seal module for substantially sealing a
10 pressurized fluid in the drive module;

11 (b) assembling the plurality of modular units into a plurality of tool sub-
12 assemblies; and

13 (c) assembling the plurality of tool sub-assemblies into a modular tool
14 for reducing pressure in the wellbore downhole of the modular tool.

1 20. A method for drilling a wellbore, comprising

2 (a) providing a drill string having a drill bit at an end thereof;

3 (b) supplying drilling fluid under pressure into the drill string (a “supply
4 fluid”), the drilling fluid returning uphole via an annulus around the drill string (a
5 “return fluid”);

6 (c) positioning a modular tool in communication with the return fluid for
7 reducing pressure in the wellbore downhole of the modular tool, said modular
8 tool having at least one interchangeable modular unit;

9 (d) creating a pressure drop in the return fluid using an active pressure
10 differential device (“APD Device”) associated with the modular tool; and

11 (e) energizing the APD Device with a drive assembly.

1 21. The method according to claim (19) wherein said modular unit is provided
2 as a plurality of modular units, each of which are interchangeable with the other
3 and each of which has a substantially different value for a selected operating
4 parameter.

1 22. The method according to claim (19) further comprising forming the APD
2 Device as the modular unit.

1 23. The method according to claim (21) further comprising forming the APD
2 Device as a plurality of modular units, each of the modular units being configured
3 to have a substantially different value for a selected operating parameter
4 selected from one of (i) pressure differential in the return fluid; (ii) rotation speed;
5 (iii) flow rate; and (iv) torque.

1 24. The method according to claim (19) further comprising forming the drive
2 assembly as the modular unit.

1 25 The method according to claim (21) further comprising forming the
2 modular units as a plurality modular units, each of said modular units being
3 configured to have a substantially different value for a selected operating
4 parameter selected from one of (i) differential pressure of the supply fluid; (ii)
5 rotation speed; (iii) flow rate; and (iv) torque.

1 26. The method according to claim (19) wherein the modular unit is selected
2 from one of (i) a comminution device for reducing the size of particles entrained
3 in the return fluid, (ii) a high-pressure seal for minimizing the leaking of
4 pressurized drilling fluid from the modular tool, and (iii) an annular seal for
5 directing return fluid into the modular tool.

1 27 A method for drilling a wellbore, comprising
2 (a) a drill string having a drill bit at an end thereof;
3 (b) supplying drilling fluid under pressure into the drill string (a "supply
4 fluid"), the drilling fluid returning uphole via an annulus around the drill string (a
5 "return fluid");
6 (c) positioning an active pressure differential device ("APD Device") in
7 communication with the return fluid to create a pressure drop across said APD
8 Device to reduce pressure in the wellbore;

9 (d) energizing the APD Device with a drive assembly coupled to the
10 APD Device; and

11 (e) sealing the pressurized drilling fluid in the drive assembly using a
12 high-pressure seal having a pre-determined rate of leakage.

1 28. The method according to claim (26) further comprising providing lateral
2 stability for a shaft associated with the drive assembly using the high-pressure
3 seal.

1 29. The method according to claim (26) further comprising cooling and
2 lubricating a bearing using the drilling fluid leaked through the high-pressure
3 seal.

1 30. The method according to claim (26) wherein the high-pressure seal
2 comprises a concentrically arranged inner sleeve and outer sleeve, the inner
3 sleeve being fixed on a shaft assembly associated with the drive assembly and
4 the outer sleeve being fixed to a housing associated with the drive assembly.

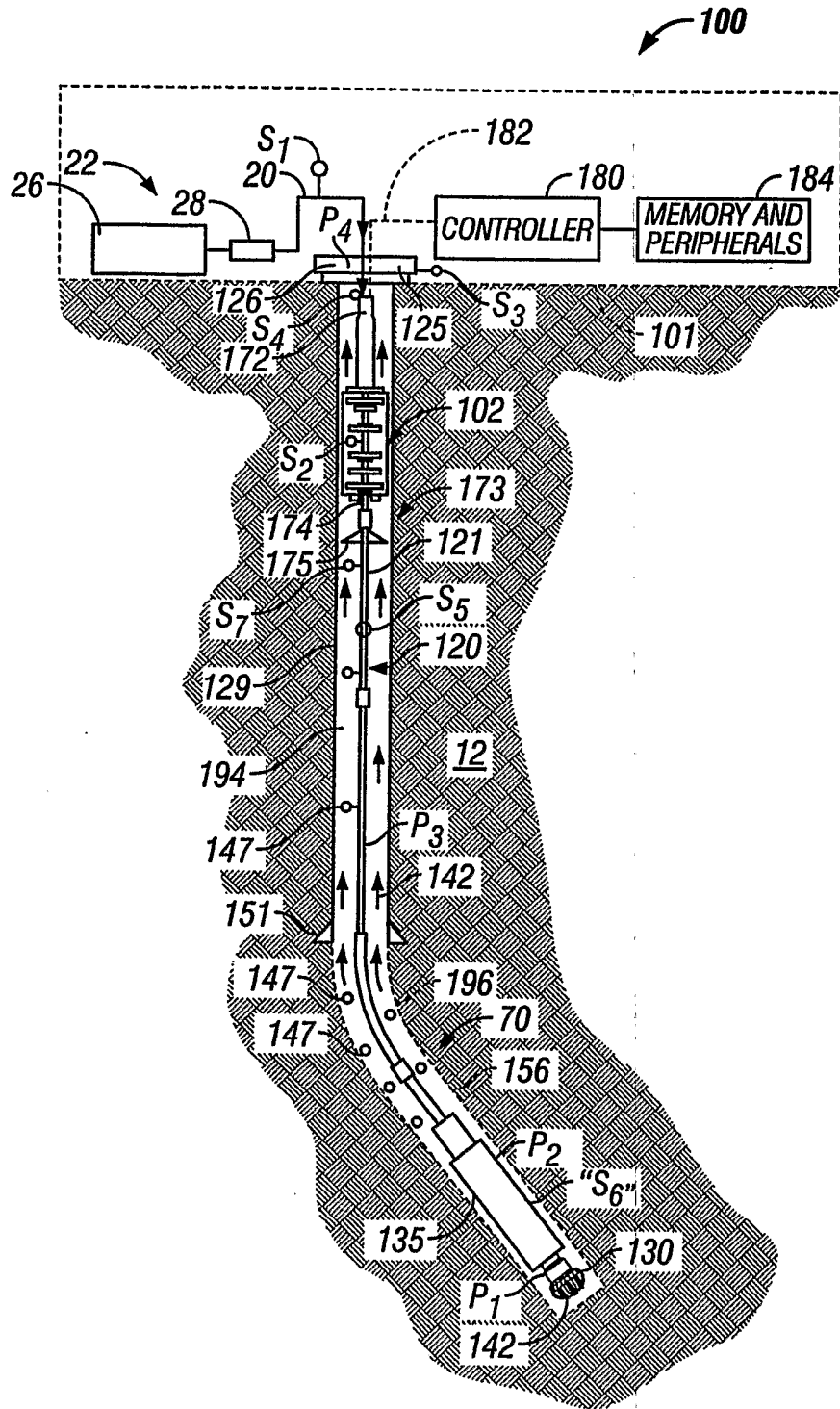
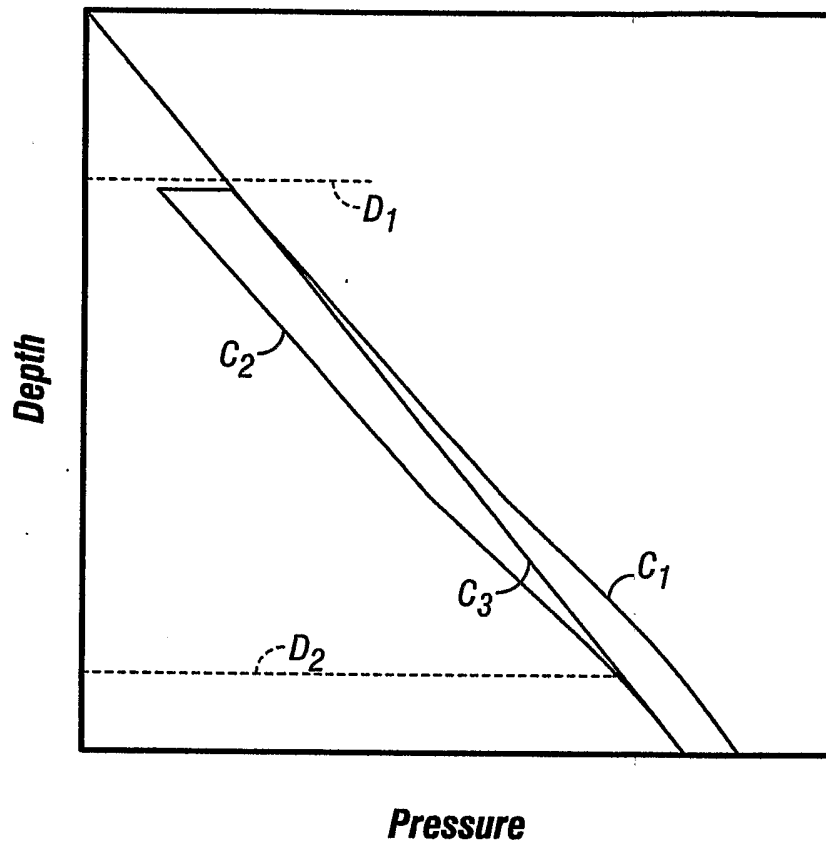

FIG. 1A



Pressure

FIG. 1B

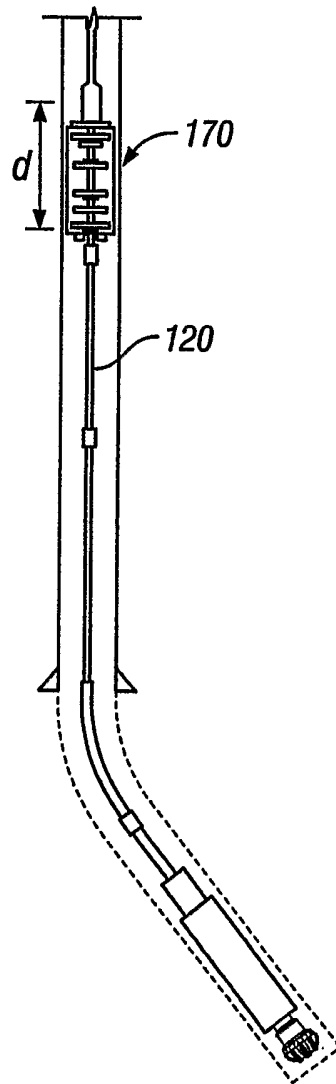

FIG. 2

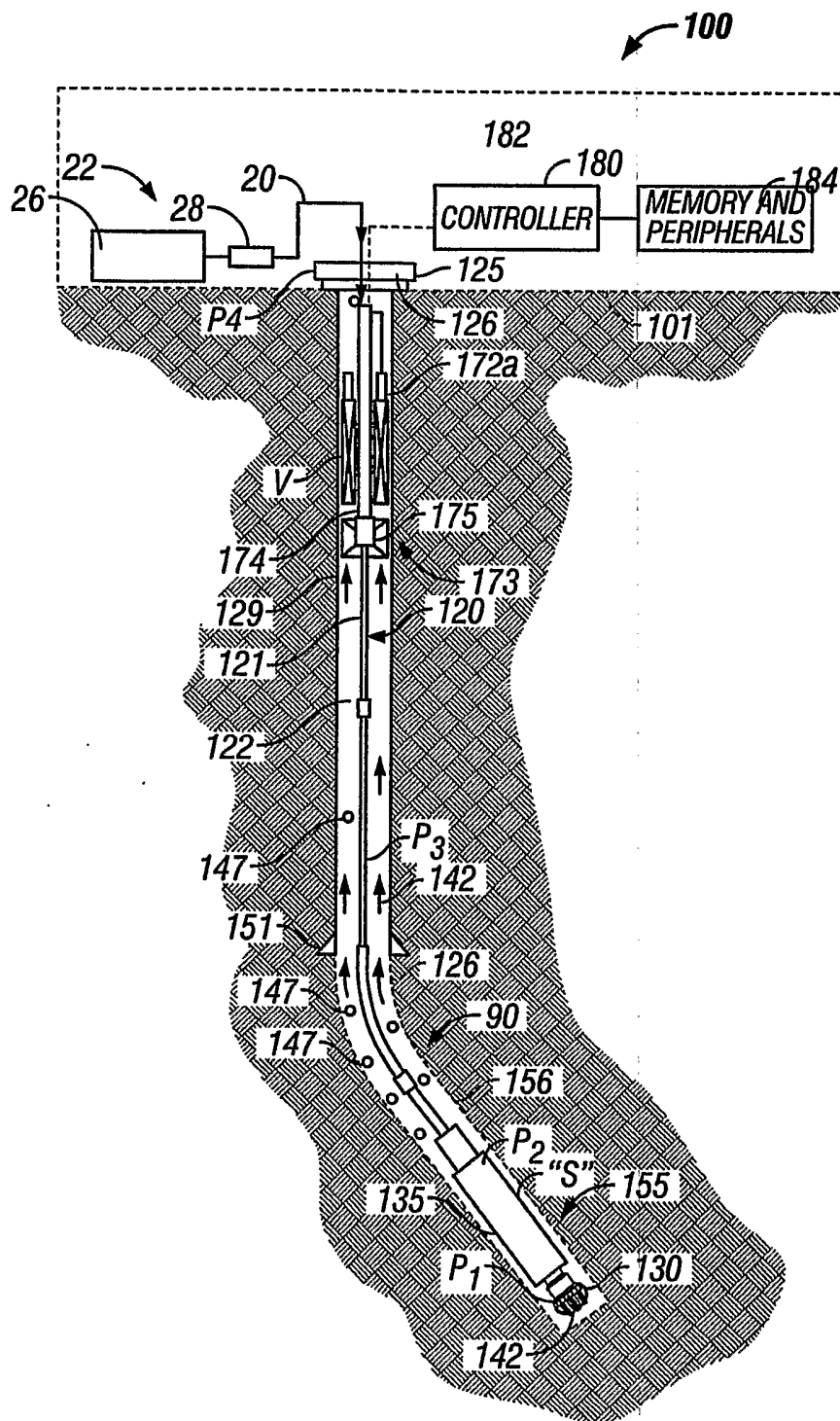

FIG. 3

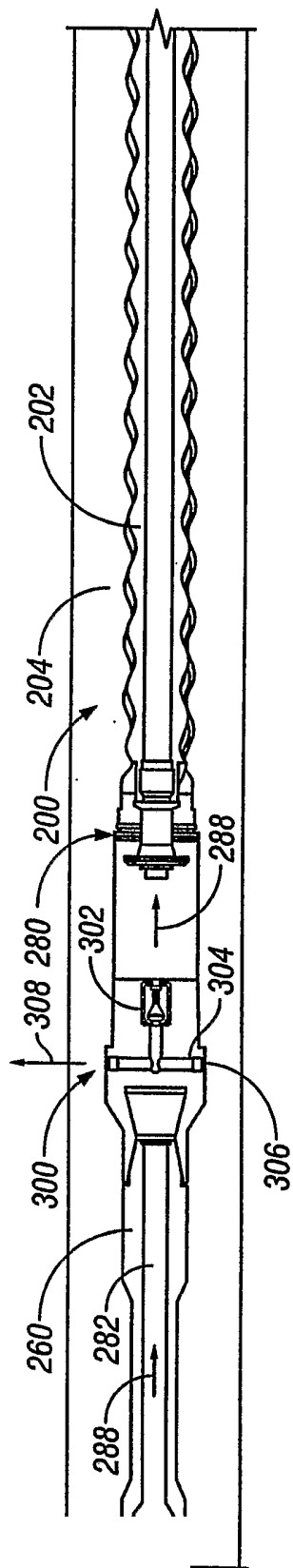

FIG. 4A

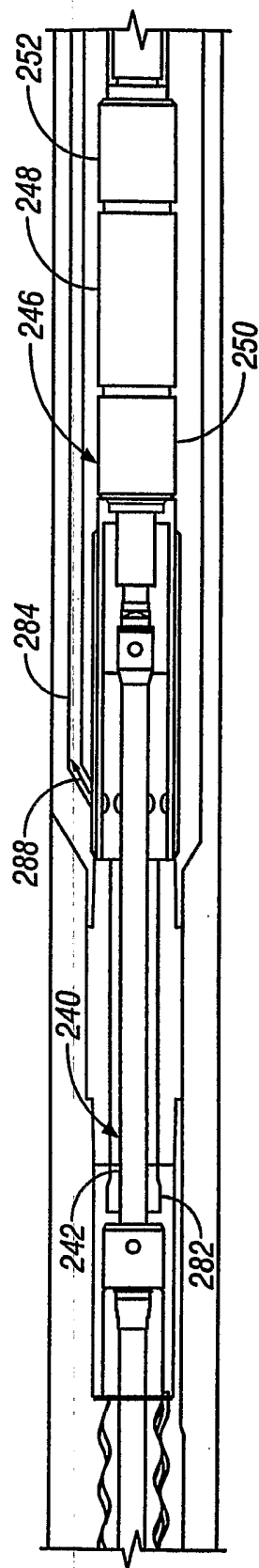

FIG. 4B

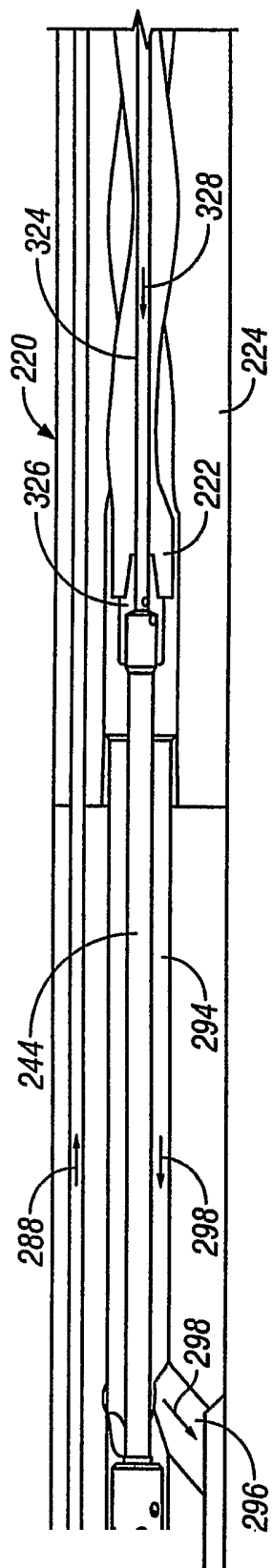

FIG. 4C

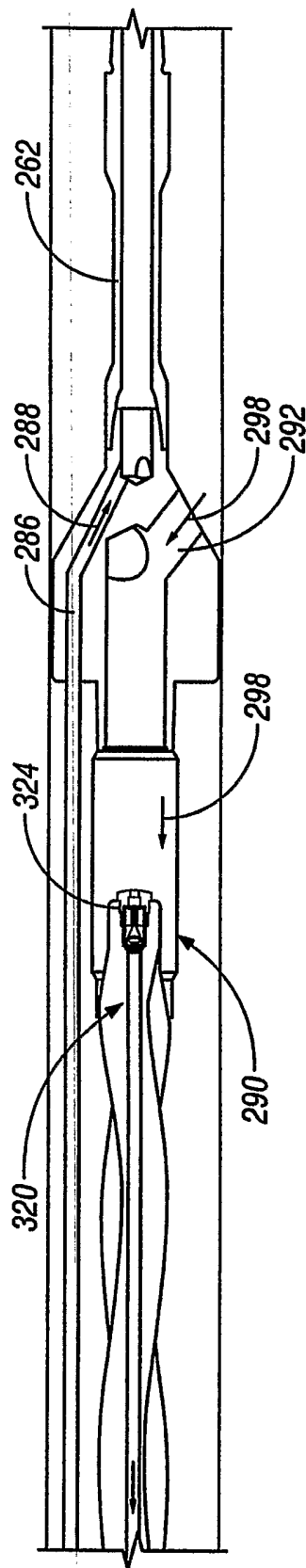

FIG. 4D

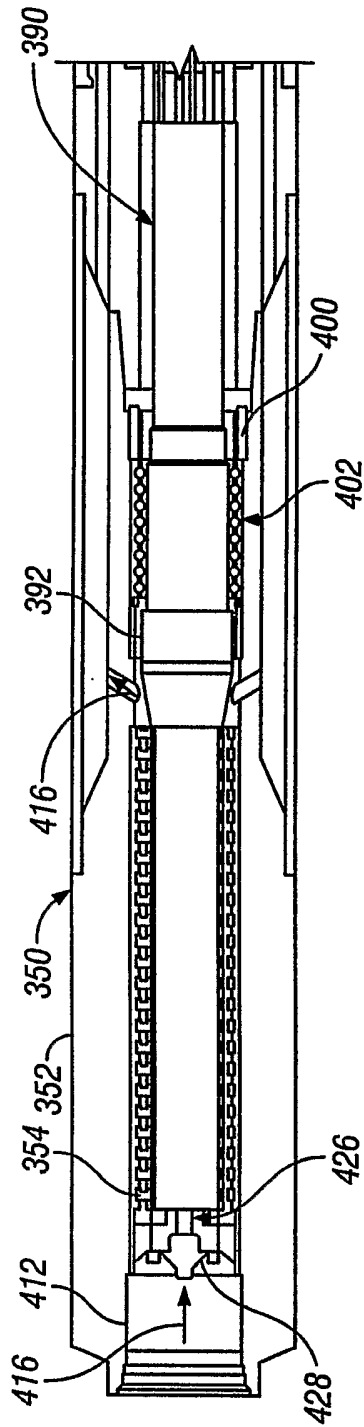

FIG. 5A

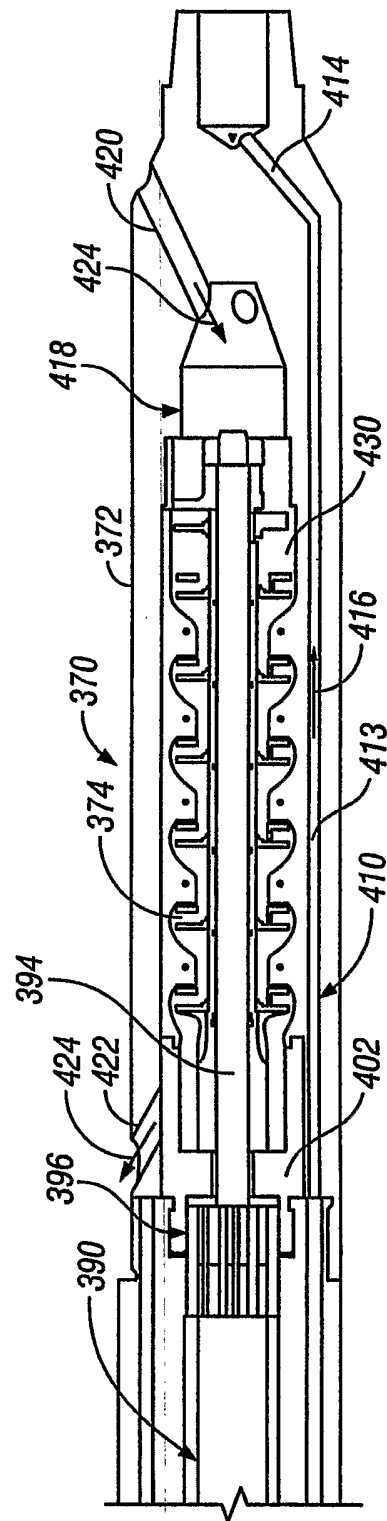

FIG. 5B

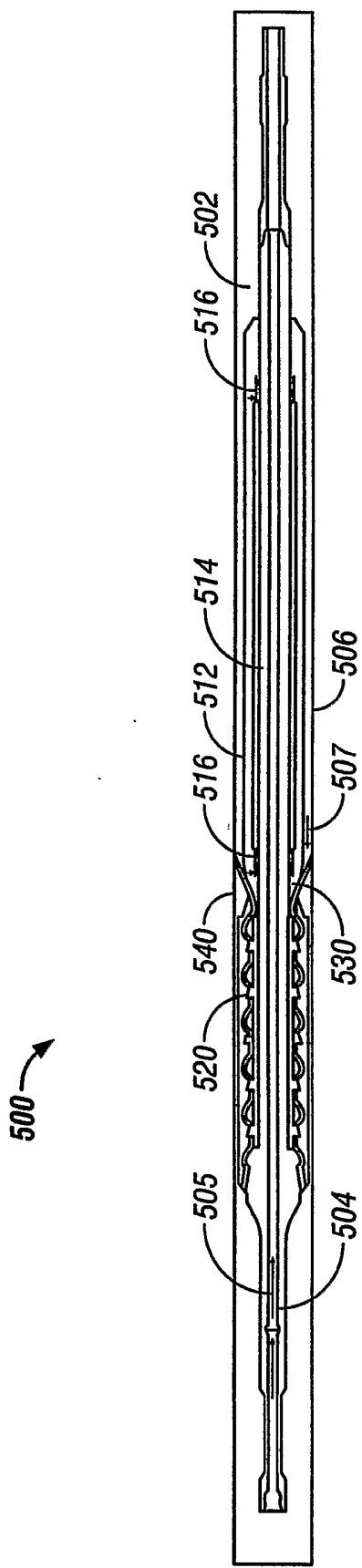

FIG. 6A

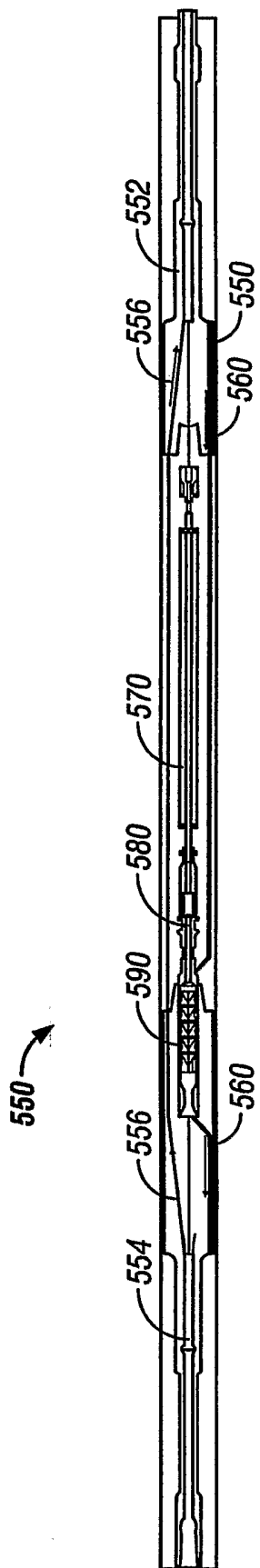

FIG. 6B

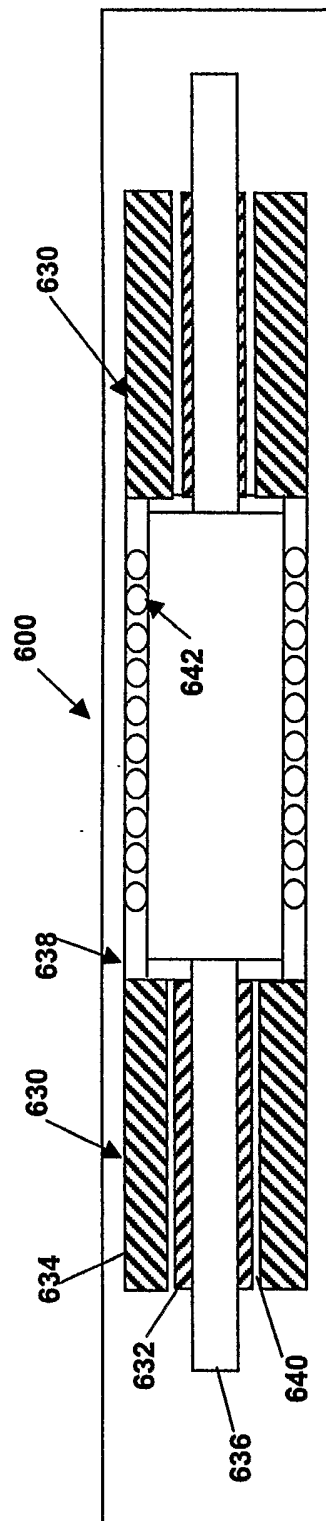

Figure 8

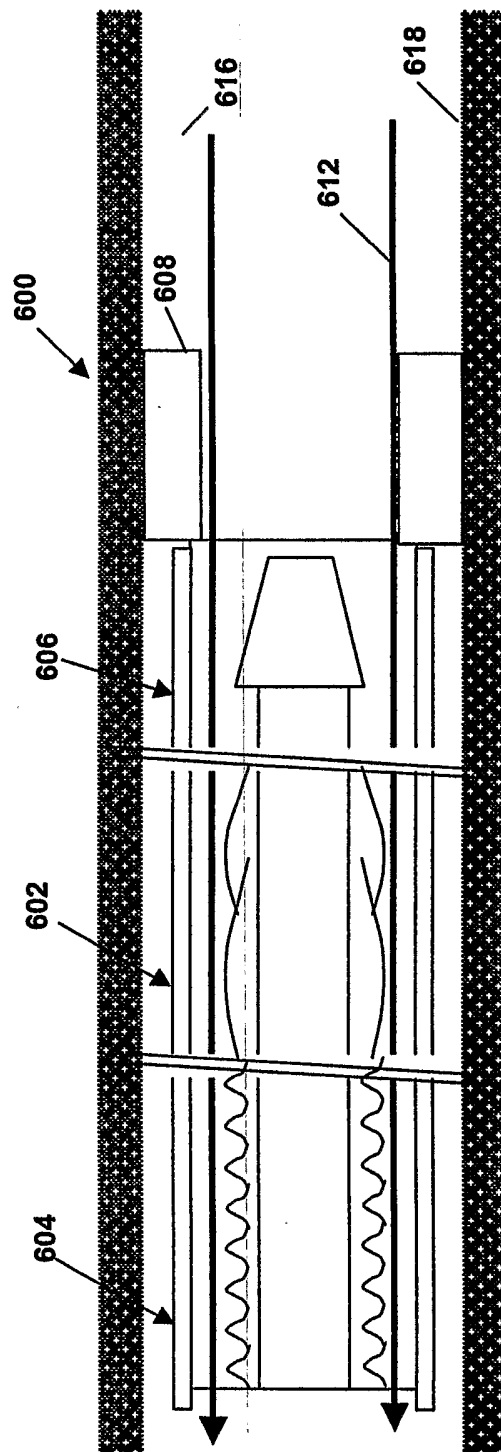

Figure 7

INTERNATIONAL SEARCH REPORT

PC1/US2005/009736

A. CLASSIFICATION OF SUBJECT MATTER
IPC 7 E21B7/12

According to International Patent Classification (IPC) or to both national classification and IPC

B. FIELDS SEARCHED

Minimum documentation searched (classification system followed by classification symbols)
IPC 7 E21B

Documentation searched other than minimum documentation to the extent that such documents are included in the fields searched

Electronic data base consulted during the international search (name of data base and, where practical, search terms used)

EPO-Internal

C. DOCUMENTS CONSIDERED TO BE RELEVANT

| Category ° | Citation of document, with indication, where appropriate, of the relevant passages | Relevant to claim No. |
|---------------|---|-----------------------|
| X | US 2003/098181 A1 (ARONSTAM PETER ET AL) 29 May 2003 (2003-05-29) claims 1-10 figure 1 | 1-30 |
| X | WO 03/025336 A (BAKER HUGHES INCORPORATED) 27 March 2003 (2003-03-27) the whole document | 1-30 |
| X | US 2003/066650 A1 (FONTANA PETER ET AL) 10 April 2003 (2003-04-10) paragraph '0024! - paragraph '0027! figures 1,2 | 1, 12, 19, 20, 27 |
| A | US 5 048 981 A (IDE ET AL) 17 September 1991 (1991-09-17) abstract | 1-30 |
| ----- -/-- | | |

Further documents are listed in the continuation of box C.

Patent family members are listed in annex.

° Special categories of cited documents:

- *A* document defining the general state of the art which is not considered to be of particular relevance
- *E* earlier document but published on or after the international filing date
- *L* document which may throw doubts on priority claim(s) or which is cited to establish the publication date of another citation or other special reason (as specified)
- *O* document referring to an oral disclosure, use, exhibition or other means
- *P* document published prior to the international filing date but later than the priority date claimed

- *T* later document published after the international filing date or priority date and not in conflict with the application but cited to understand the principle or theory underlying the invention
- *X* document of particular relevance; the claimed invention cannot be considered novel or cannot be considered to involve an inventive step when the document is taken alone
- *Y* document of particular relevance; the claimed invention cannot be considered to involve an inventive step when the document is combined with one or more other such documents, such combination being obvious to a person skilled in the art.
- *&* document member of the same patent family

Date of the actual completion of the international search

Date of mailing of the international search report

22 June 2005

01/07/2005

Name and mailing address of the ISA
European Patent Office, P.B. 5818 Patentlaan 2
NL - 2280 HV Rijswijk
Tel. (+31-70) 340-2040, Tx. 31 651 epo nl,
Fax: (+31-70) 340-3016

Authorized officer

Stroemmen, H.

INTERNATIONAL SEARCH REPORT

PCT/US2005/009736

| C.(Continuation) DOCUMENTS CONSIDERED TO BE RELEVANT | | |
|--|--|-----------------------|
| Category * | Citation of document, with indication, where appropriate, of the relevant passages | Relevant to claim No. |
| A | EP 0 293 251 A (CONOCO INC) 30 November 1988 (1988-11-30) abstract ----- | 1-30 |

INTERNATIONAL SEARCH REPORT

Information on patent family members

PC 1 / JS2005/009736

| Patent document cited in search report | Publication date | Patent family member(s) | Publication date |
|--|------------------|-------------------------|------------------|
| US 2003098181 A1 | 29-05-2003 | US 2004069504 A1 | 15-04-2004 |
| | | US 2004112642 A1 | 17-06-2004 |
| | | US 2004206548 A1 | 21-10-2004 |
| | | US 2004256161 A1 | 23-12-2004 |
| | | US 2005098349 A1 | 12-05-2005 |
| | | BR 0212667 A | 05-10-2004 |
| | | CA 2459723 A1 | 27-03-2003 |
| | | GB 2396875 A | 07-07-2004 |
| | | WO 03025336 A1 | 27-03-2003 |
| WO 03025336 A | 27-03-2003 | BR 0212667 A | 05-10-2004 |
| | | CA 2459723 A1 | 27-03-2003 |
| | | GB 2396875 A | 07-07-2004 |
| | | WO 03025336 A1 | 27-03-2003 |
| | | US 2003098181 A1 | 29-05-2003 |
| | | US 2004112642 A1 | 17-06-2004 |
| | | US 2004206548 A1 | 21-10-2004 |
| | | US 2004256161 A1 | 23-12-2004 |
| | | US 2005098349 A1 | 12-05-2005 |
| US 2003066650 A1 | 10-04-2003 | GB 2389130 A | 03-12-2003 |
| | | NO 20031087 A | 08-05-2003 |
| | | WO 03006778 A1 | 23-01-2003 |
| US 5048981 A | 17-09-1991 | CA 2049586 A1 | 25-02-1992 |
| | | DE 4127977 A1 | 27-02-1992 |
| | | GB 2247262 A | 26-02-1992 |
| EP 0293251 A | 30-11-1988 | US 4784527 A | 15-11-1988 |
| | | CA 1304735 C | 07-07-1992 |
| | | DK 287088 A | 30-11-1988 |
| | | EP 0293251 A2 | 30-11-1988 |
| | | JP 1214688 A | 29-08-1989 |
| | | NO 882345 A | 30-11-1988 |