

No. 817,551.

PATENTED APR. 10, 1906.

G. ELLER.

PERMUTATION LOCK.

APPLICATION FILED NOV. 19, 1904.

3 SHEETS—SHEET 1.

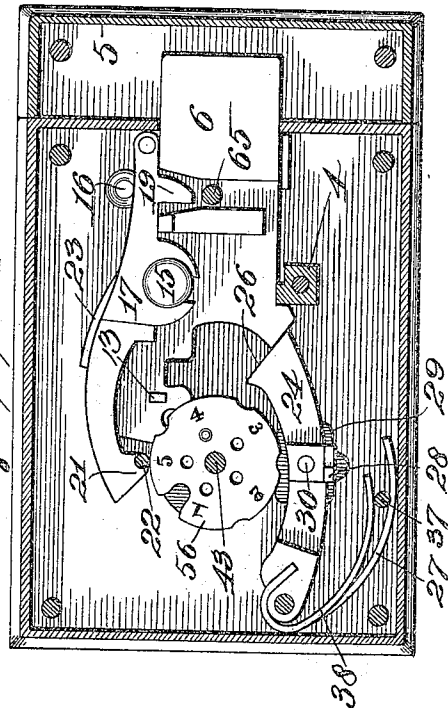
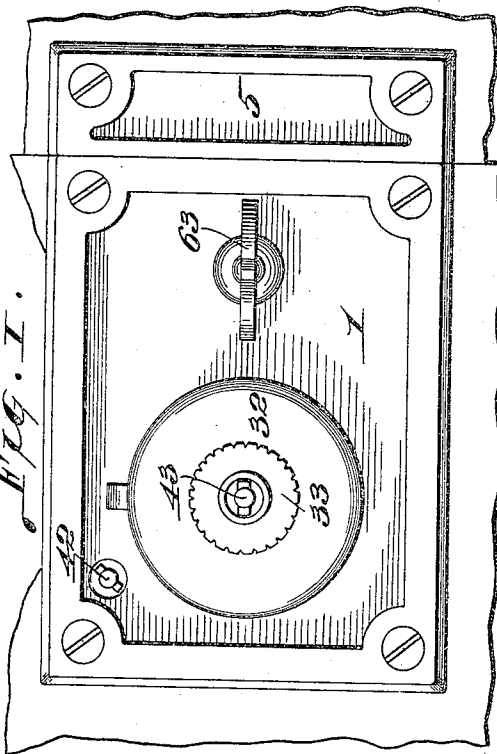
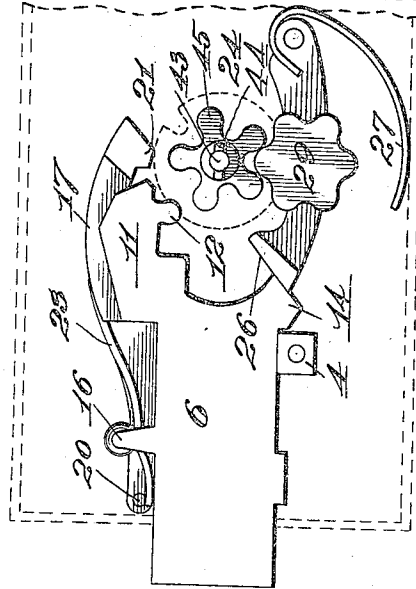
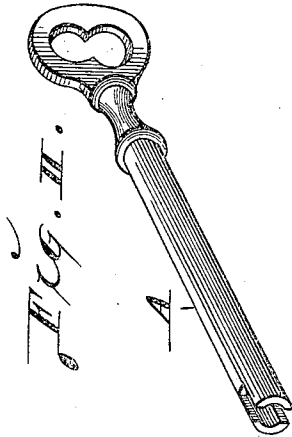

attest: —
 M. Smith,
 Blanche Hogue

Inventor: —
 Geo. Eller: —
 By Wright Bro
 Attys.

No. 817,551.

PATENTED APR. 10, 1906.

G. ELLER.
PERMUTATION LOCK.
APPLICATION FILED NOV. 19, 1904.

3 SHEETS—SHEET 2.

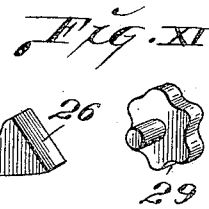
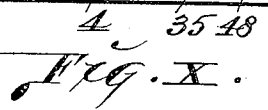
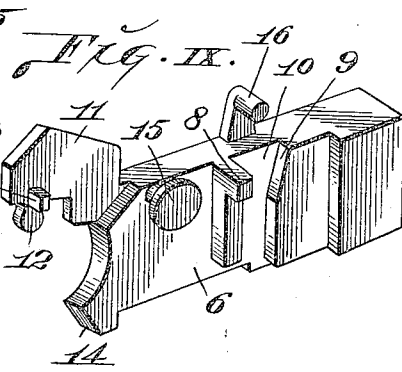
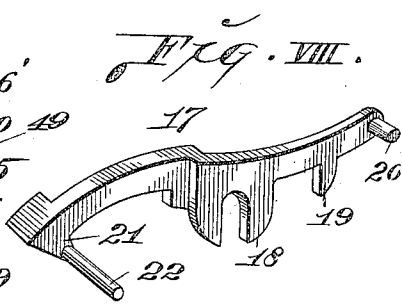
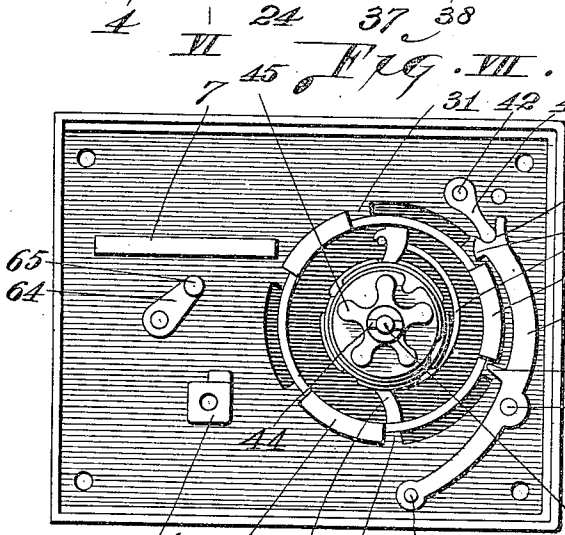
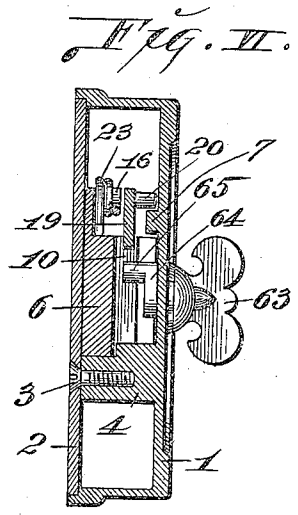
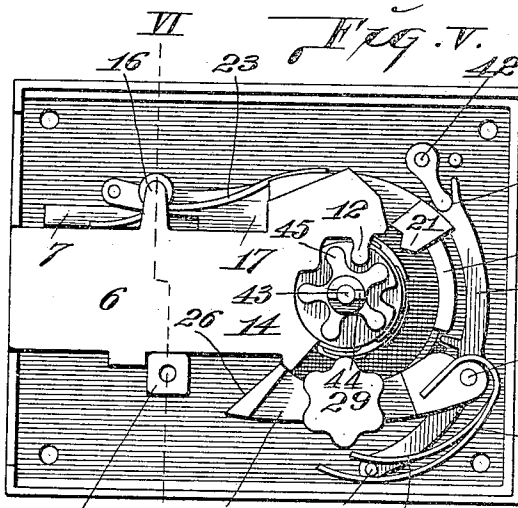

attest:-
M. Smith
Blanche Hogan

Inventor:-
George Eller.
 By *Wright & Pro*
attys.

G. ELLER.
PERMUTATION LOCK.
APPLICATION FILED NOV. 19, 1904.

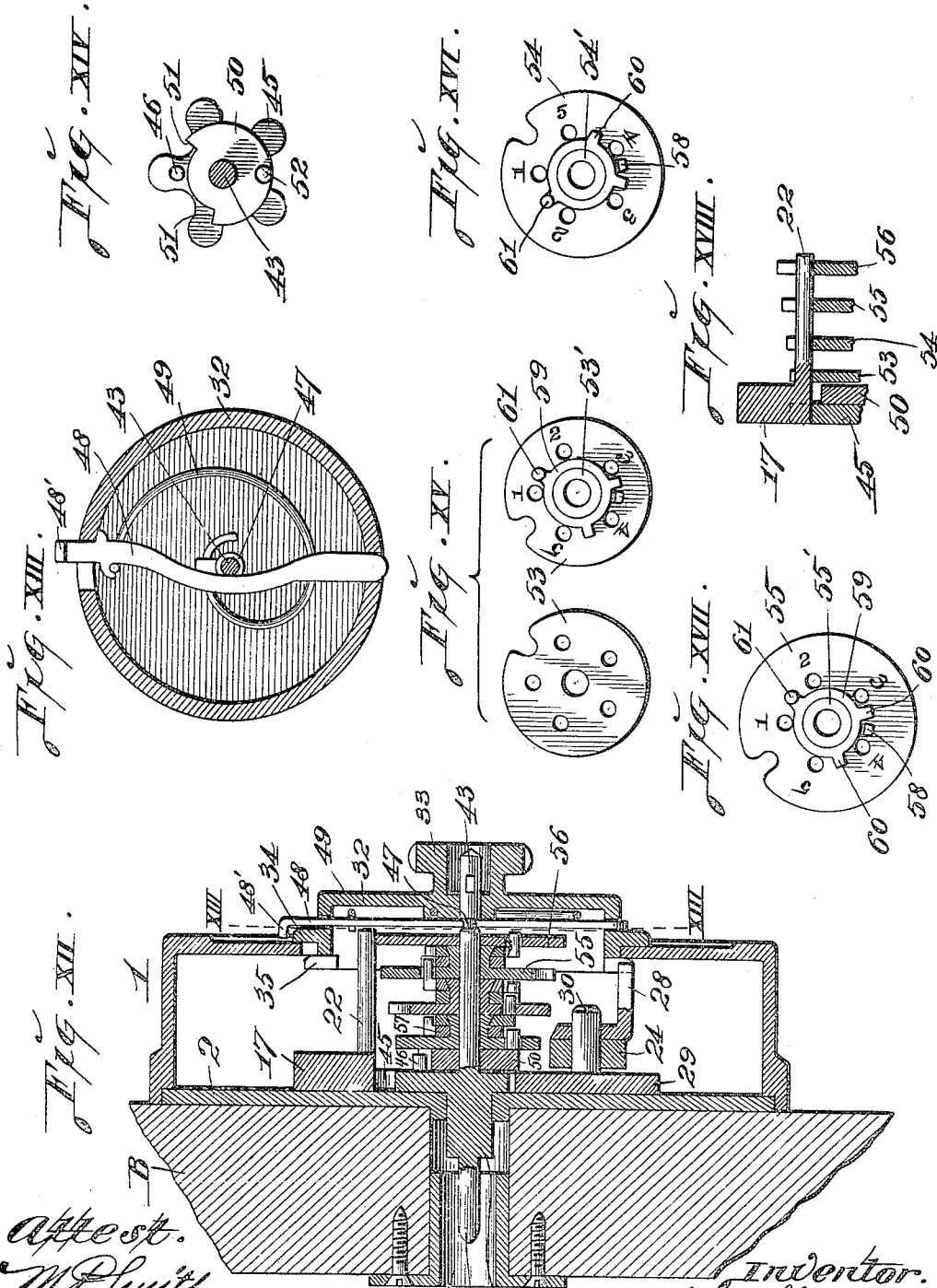

Attest.
W. Smith,
Blanche Hoque.

Inventor.
Geo. Eller.
 By *Wright Bros.*
attys.

UNITED STATES PATENT OFFICE.

GEORGE ELLER, OF ST. LOUIS, MISSOURI.

PERMUTATION-LOCK.

No. 817,551.

Specification of Letters Patent.

Patented April 10, 1906.

Application filed November 19, 1904. Serial No. 233,584.

To all whom it may concern:

Be it known that I, GEORGE ELLER, a citizen of the United States, residing in the city of St. Louis, in the State of Missouri, have invented certain new and useful Improvements in Permutation-Locks, of which the following is a full, clear, and exact description, reference being had to the accompanying drawings, forming part of this specification.

My invention relates to an improvement in permutation-locks more especially intended for use upon the doors of buildings, but susceptible of use in other connections.

Figure I is a front elevation of my lock.

Fig. II is a perspective view of the lock-key.

Fig. III is a longitudinal section of the lock.

Fig. IV is a side view of the lock-bolt and other parts closely associated therewith.

Fig. V is a view of the lock mechanism with

the back of the case omitted. Fig. VI is a

cross-section taken on line VI VI, Fig. V,

with the back of the lock-case in position.

Fig. VII is a view similar to Fig. V, with the

lock-bolt, the click-wheel-carrying arm, the

click-wheel, and throw-bar omitted. Fig.

VIII is a perspective view of the bolt throw-

bar. Fig. IX is a perspective view looking at

the front side of the lock-bolt. Fig. X is a

perspective view of the click-wheel-carrying

arm. Fig. XI is a perspective view of the click-

wheel. Fig. XII is an enlarged cross-section

taken through the complete lock applied to a

door. Fig. XIII is a section taken on line

XIII XIII, Fig. XII. Fig. XIV is a side view

of the tumbler-driving wheel and driving-

tumbler with the tumbler-arbor shown in

cross-section. Fig. XV comprises views of the

obverse and reverse sides of the second tum-

bler. Fig. XVI is a face view of the third

tumbler. Fig. XVII is a face view of the

fourth tumbler. Fig. XVIII is a section

taken through fragments of the tumblers in

assembled position and the pin of the throw-

bar seated in the notches in said tumblers.

1 designates the main portion of the case of

my lock, and 2 the case-back, that is secured

to the main portion of the case by a screw 3,

which enters a stud 4, that in addition to its

office as a connecting member for the main

portion of the case and its back serves as a

guide member for the lock-bolt, as will here-

inafter appear.

5 is a keeper that corresponds in shape to

the end of the case 1, said case being provided

with an aperture through which the bolt is projected to enter said keeper.

6 designates the lock-bolt that is positioned in the case 1 to reciprocate through an aperture in the forward end wall of the case, as seen in Figs. III and V. This bolt rides between the stud 4 and a lug 7, (see Figs. III, V, and VII,) the lug serving in addition to its office as a guide as a stop for a member to be hereinafter referred to. At the forward side of the bolt 6 is a boss 8, that rides against the under side of the lug 7, and spaced apart from said boss on the bolt is a shoulder 9, between which and said boss is a space 10, that receives a part to be hereinafter mentioned. At the rear end of the bolt 6 is an arm 11, which is provided with a tooth 12 at its lower edge and bears a stop-lug 13 at its front side. At the bottom of the rear end of the bolt is a downwardly-inclined extension 14. At the front side of the bolt 6 and near its rear end is a swivel-stud 15.

16 is a stud-arm projecting upwardly from the bolt 6 and forming a part thereof.

17 designates a bolt throw-bar that is provided with a fork 18, which fits loosely onto the swivel-stud 15 of the bolt 6 and is located intermediate of the ends of said bar. The fork 18 being located intermediate of the ends of the throw-bar divides said bar to provide a forward arm and a rear arm. The forward arm of the bar bears a downwardly-extending finger 19, that enters the space 10 in the bolt 6, and also a pin 20, that is adapted to ride on the case-lug 7 to pass into a position in front of the forward end of said lug when the bolt 6 is projected, as will hereinafter be more particularly referred to. The rear arm of the throw-bar 17 bears a tooth 21, that carries a throw-pin 22.

23 (see Figs. III, IV, V, and VI) is a spring fitted to the stud-arm 16 and bearing against the throw-bar 17 to yieldingly maintain the rear end of said bar in a position resting against the stop-lug 13 on the bolt-arm 11. The spring 23 is coiled around the stud-arm 16, as seen most clearly in Fig. IV, and it has two projecting arms, one of which rests upon the rear end of the throw-bar 17 and the other of which extends in the opposite direction and rests upon the bolt 6, as seen most clearly in Fig. V. It will be seen that due to the rearwardly-extending spring-arm being seated upon the bolt 6 the forward arm of the

spring is restrained from upward movement except with yielding action, thereby causing it to control the movement of the throw-bar 17 to hold said throw-bar in a normally depressed position.

24 designates a click-wheel-carrying arm that is mounted on a pivot-pin 25, carried by the front wall of the case. This pin is located in a position rearward from the rear end of the bolt 6. The arm 24 extends forwardly toward the bolt 6 and is provided with an inclined forward end 26, that is adapted to engage the inclined extension 14 of said bolt.

27 is a spring secured to the arm 24 and bearing against the lock-case, which acts to hold the free forward end of the arm in contact with the extension 14.

28 is a stop-finger projecting from the arm 24 at its lower side, the utility of which will be hereinafter mentioned.

29 is a click-wheel, the shank 30 of which is loosely seated in the arm 24.

In the inner wall of the lock-case is an opening for the reception of the tumbler-barrel, (see Figs. V, VI, and XII,) in which are tongues 31.

32 designates the tumbler-barrel provided with a handle 33. This tumbler-barrel has an annular flange 34, that fits against the outer face of the lock-case, and it is provided at its inner end with lips 35, which are adapted to pass through the spaces between the tongues 31 and ride onto the inner faces of said tongues when the barrel is set into and rotated in the opening in the lock-case.

36 designates a latch that is loosely mounted intermediate of its ends upon the pivot-pin 25, the lower arm of the latch being equipped with a pin 37, that engages a spring 38, carried by the click-wheel arm 24, as seen in Figs. III and V. I prefer to utilize the spring 38 in connection with the latch-pin 37; but it is obvious that the spring 27, closely associated with the spring 38 and also carried by the click-wheel arm 24, may bear against the pin 37, thereby causing one spring to perform two offices. The spring 38, that bears against the pin 37 at the lower end of the latch 36, serves to hold the upper arm of the latch projected toward the lips 35 of the tumbler-barrel, and the upper arm of the latch is provided with catch-fingers 39 and 40, between which one of the lips 35 may pass, as seen most clearly in Fig. VII, to hold the tumbler-barrel from rotation and retain it seated in the lock-case after the lips have been rotated into position to engage the tongues 31 of the case.

41 is a release-arm that is carried by a key-shaft 42, and the free end of which seats in a socket 36' in the end of the upper arm of the latch 36. The key-shaft 42 is loosely seated in the outer wall of the lock-case and extends to the inner-side of the case, as seen in Fig. I, so that a key or other suitable implement

may be applied thereto to rotate said shaft and release the latch 36 from engagement with the lips of the tumbler-barrel when it is desired to remove said barrel from the lock-case for any purpose, such as changing the combination of the tumblers that are carried by said barrel and will be presently described.

43 designates the arbor on which the tumblers of my lock are mounted. This arbor is provided at one end with a key-receiving head 44, to which the key A (shown in Fig. II) may be applied. The key-receiving head of the arbor is journaled in an aperture in the back 2 of the lock-case, and the opposite end of the arbor is rotatably seated in the tumbler-barrel. In the arbor near the last-mentioned end is an annular groove 47.

48 is a catch-bar that passes loosely through the tumbler-barrel (see Figs. XII and XIII) and the central portion of which is adapted to seat in the groove 47 of the tumbler-arbor to hold said arbor to the tumbler-barrel. The catch-bar 48 is held in engagement with the arbor through the medium of a spring 49, and the catch-bar is provided with a handle 48', located exterior of the tumbler-barrel, by which said catch-bar may be shifted laterally to disengage it from the arbor and permit the removal of said arbor from the barrel.

45 designates a tumbler-driving wheel that is integral with the arbor 43 and bears a pin 46. (See Figs. XII and XIV.)

50 designates a driving-tumbler loosely mounted on the arbor 43 and provided at its perimeter with a notch furnishing shoulders 51, between which the pin 46 of the tumbler-driving wheel may play and with which said pin engages when the driving-wheel 45 has been rotated to bring the pin to either shoulder that it is caused to approach. The driving-tumbler 50 bears a pin 52.

53, 54, 55, and 56 designate tumblers loosely mounted on the arbor 43 and which are of increasing diameters in the order named, the tumbler 53 of the smallest diameter being located on the arbor adjacent to the driving-tumbler 50, as seen in Figs. XII and XVIII. Each of these tumblers is provided with a plurality of pin-holes corresponding in number to the number of teeth of the tumbler-driving wheel 45 and with a single notch at the periphery thereof that is of sufficient dimensions to receive the throw-pin 22, carried by the throw-bar 17, when the tumbler is rotated to bring the notch into position to be engaged by said pin. The tumblers 53, 54, and 55 are provided with hubs 53', 54', and 55'.

57 represents primary tumbler-driving rings loosely mounted upon said tumbler-hubs adjacent to the forward faces of each of the tumblers 53, 54, and 55 and each provided with an angle-arm 58, located at the periphery of the ring.

59 represents secondary tumbler-driving

rings loosely fitted to the tumbler-hubs and lying flatly against the primary driving-rings. Each of these secondary driving-rings is provided with a pair of tongues 60, that project from the peripheries of the rings at opposite sides of the angle-arms of the primary rings. Each secondary driving-ring is also equipped with a pin 61, extending at right angles to the face of the ring.

One face of each of the tumblers 53, 54, 55, and 56 bears a series of characters, such as numerals, placed thereon to indicate the various pin-holes in the tumblers, as seen in Figs. III and XV to XVII, inclusive. Either of the pin-holes in the innermost tumbler 53 is designed to receive a pin 52 of the driving-tumbler 50, and the said pin is of sufficient length to project through the tumbler 53 to a degree that will permit of its engaging the angle-arm of the primary tumbler-driving ring 57 next adjacent to the tumbler 53, as seen in Fig. XII. The secondary driving-ring 59, that is associated with the primary driving-ring just referred to, is arranged to be driven by said primary driving-ring when said primary ring has rotation imparted to it by virtue of the engagement of the driving-tumbler pin 52 therewith through contact of said pin with the primary driving-ring arm 58. When said arm 58 is rotated, it is moved to one of the tongues 60. When the secondary ring is rotated, its pin 61, which projects through one of the pin-holes in the next adjacent tumbler 54 to the primary tumbler-driving ring carried thereby, is caused to move in a circuit corresponding to the direction of movement of the ring. This order of the parts is continued throughout the tumblers.

In Fig. XII, I have shown my lock applied to a door B, provided with a keyhole to which is applied an escutcheon 62, through which the key A (seen in Fig. II) may be introduced to turn the tumbler-arbor 43 and manipulate the tumblers in a manner to operate the lock in retracting its bolt.

For the purpose of providing for the throwing of the lock-bolt 6 at the opposite side of the lock from that at which the parts are manipulated by a key through the medium of which the tumblers are actuated I provide a button 63, (see Figs. I and VI,) the shank of which is rotatably seated in the lock-case and carries a crank-arm 64, located within the lock-case and provided with a finger 65, that is adapted to operate in the space 10 in the lock-bolt. (See Figs. III, VI, and VII.) The button 63 may be turned at any time to rock the crank-arm and throw the bolt, due to the finger of the crank-arm operating within the space 10 against the bolt-boss 8 or shoulder 9. When the bolt is in projected position, the finger of the crank-arm operates first against the finger 19 of the throw-bar 17 to elevate the forward end of the throw-bar

and release the pin 20 from the forward end of the guide and stop-lug 7, with which said pin engages when the lock is in projected position.

In the practical use of my permutation-lock the operation of the parts is as follows: Assuming the bolt 6 to be in projected position, as seen in Figs. III and IV, the tumblers and parts associated therewith on the tumbler-arbor are free, so that the arbor may be rotated and all parts associated therewith partake of a movement corresponding to that imparted to the arbor. The various tumblers, which may be of the number illustrated or of any other desirable number, may have been set on any desirable combination according to whatever pin-holes in the tumblers the pins to actuate them are entered into. For the purpose of illustration it will be assumed that the pins are seated in the tumblers in holes corresponding to the indicating-numeral "4," borne by each tumbler. The first act in beginning to work the combination and put the tumblers into such condition that they will cause the lock-bolt to be withdrawn is that of rotating the tumbler-arbor through the medium of the key in a right-hand direction until all of the tumblers are assembled, or, in other words, until the various pins have rotated the tumblers to bring the primary and secondary driving-rings 57 and 59 into interlocked condition. At this time the throw-pin 22 of the throw-bar 17 rests against the periphery of the largest tumbler 56, as seen most clearly in Fig. XII. The tumbler-arbor is then rotated in a reverse direction or to the left to an extent that will cause all of the primary and secondary driving-rings to be brought again into interlocked condition. The movement is continued until the largest tumbler 56 is rotated to a sufficient degree to bring its notch to the throw-pin 22, and when the notch is brought thereto the said pin moves into the notch, due to the action of the spring 23 against the throw-bar 17. The tumbler 56 is now held from rotation in either direction, and the throw-pin rests against the periphery of the second largest tumbler 55 to restrain it from rotation by frictional contact, while the arbor is rotated reversely or again toward the right to cause the unrestrained tumblers 53 and 54 to be rotated until the tumbler 55 is picked up by the interlocking of the tumbler members that are being rotated by the arbor, due to which the notch in the tumbler 55 is finally brought to the throw-pin 22, so that said pin may enter into said notch and hold said tumbler and at the same time rest upon the periphery of the next largest tumbler 54. This operation is continued until all of the tumblers are in engagement with the throw-pin, as seen in Fig. XVIII. When the throw-pin enters into all of the tumbler-notches, the forward end of the throw-arm 17 becomes

elevated, thereby withdrawing the pin 20 from the stop-lug 7, so that the throw-arm may move with the lock-bolt when it is retracted. The operator after having secured
 5 alinement of the tumblers in the manner explained and the entrance of the throw-pin into the tumbler-notches again reverses the rotation of the tumbler-arbor to an extent to cause the tooth 21 of the throw-bar 17 to enter
 10 between two of the teeth of the tumbler-driving wheel 45, as seen in Fig. XVIII. Rotation of the arbor is again reversed and a tooth of the driving-wheel catches the throw-bar tooth and acts thereagainst to carry the
 15 throw-bar rearwardly, the lock-bolt being slightly moved with said throw-bar. A tooth of the tumbler-driving wheel immediately thereafter engages the tooth 12 of the lock-bolt, and as the arbor is rotated the
 20 bolt is retracted into its case. During all the movements of the tumbler-arbor the degree of rotation thereof is indicated by the click-wheel 29, due to the tumbler-driving wheel operating thereagainst. This click-wheel is held firmly to the tumbler-driving wheel by
 25 reason of its being rotatably mounted in the spring-controlled arm 24. The combination on which the tumblers are set being known, the specific number of clicks of the click-wheel against the tumbler-driving wheel are readily known, and the arbor is rotated
 30 forward and backward the requisite degree in each successive rotation by counting the clicks sounding after starting from the proper starting-point, which is previously determined.

In conclusion I wish to call attention to an important feature of my lock, which is that of providing means by which removal of the
 40 tumbler-barrel is prohibited while the lock-bolt is in projected position. This means consists of the stop-finger 28, carried by the click-wheel arm 24. When the lock-bolt is in projected position, the stop-finger rests
 45 against one of the lips 35 of the tumbler-barrel (see Fig. XII) and prevents rotation of the barrel for its removal while the finger is in such position. When, however, the lock-bolt is retracted, the click-wheel arm is
 50 thrown outwardly into the position seen in Fig. V, due to the inclined extension 14 of the lock-bolt riding against the inclined forward end 26 of the click-wheel arm, thereby
 55 moving the stop-finger away from the lip 35 it previously engaged and permitting rotation of the tumbler-barrel after the latch 36 is withdrawn therefrom in the manner previously explained.

My permutation-lock being provided with
 60 a click-wheel, as described, renders it such that it may be readily operated by either a deaf or blind person as well as one having the senses of hearing and sight, as a vibration occurs in the operation of the key due to the
 65 action of the click-wheel, so that the sense of

feeling serves to inform the operator of the movement of the key and click-wheel.

I claim as my invention—

1. In a permutation-lock, the combination of a bolt, a throw-bar movably fitted to
 70 said bolt, a throw-pin carried by said throw-bar, a tumbler-arbor, a series of notched tumblers loosely mounted on said arbor and arranged to receive said throw-pin, means interposed between said tumblers for imparting
 75 rotation thereto, a driving-tumbler loosely fitted to said arbor and arranged in engagement with one of said tumblers, a driving-wheel fixed to said arbor and provided with means for engaging said driving-
 80 tumbler, and a click-wheel arranged in engagement with said driving-wheel, substantially as set forth.

2. In a permutation-lock, the combination of a bolt, a throw-bar movably fitted to
 85 said bolt, a throw-pin carried by said throw-bar, a tumbler-arbor, a series of notched tumblers loosely fitted to said arbor and arranged to receive said throw-pin, primary driving-rings carried by said tumblers and
 90 secondary driving-rings carried by said tumblers and arranged to be engaged by said primary driving-rings; said secondary driving-rings being arranged in engagement with tumblers adjacent to those by which they
 95 are carried, substantially as set forth.

3. In a permutation-lock, the combination of a bolt, a throw-bar movably fitted to
 100 said bolt, a throw-pin carried by said throw-bar, a series of notched tumblers arranged for engagement with said throw-pin, an arbor on which said tumblers are loosely fitted, a tumbler-driving wheel fixed to said arbor, a click-wheel bearing against said driving-wheel, and a spring-controlled arm by which
 105 said click-wheel is carried, substantially as set forth.

4. In a permutation-lock, the combination of a case, a bolt slidably mounted in said
 110 case, a throw-bar carried by said bolt and movable with respect thereto, a throw-pin carried by said throw-bar, a series of tumblers arranged to be engaged by said throw-pin, an arbor on which said tumblers are mounted, a tumbler-barrel removably fitted
 115 in said case in which said arbor is fitted, a tumbler-driving wheel fixed to said arbor, a click-wheel engaging said tumbler-driving wheel, a spring-controlled arm carrying said click-wheel, and a stop projecting from said
 120 arm and arranged for engagement with said tumbler-barrel, substantially as set forth.

5. In a permutation-lock, the combination of a case provided with an opening, a
 125 tumbler-barrel removably seated in said opening and provided with lips, a latch-lever pivoted to said case and arranged for engagement with said barrel-lips, a release-arm having engagement with said latch, a tumbler-arbor fitted in said barrel, a series of tum-
 130

blers carried by said arbor, a bolt, and bolt-controlling means carried by said bolt arranged to receive the engagement of said tumblers, substantially as set forth.

5 6. In a permutation-lock, the combination of a bolt provided with an inclined extension-arm, a spring-controlled pivotally-mounted click-wheel-carrying arm having an inclined free end opposing said inclined extension, a click-wheel journaled in said arm, a

tumbler-arbor, a series of tumblers carried by said arbor, a tumbler-driving wheel fixed to said arbor and engaging said click-wheel, and bolt-controlling means carried by said bolt arranged for engagement with said tumblers, substantially as set forth. 15

GEORGE ELLER.

In presence of—

BLANCHE HOGAN,
E. S. KNIGHT.