



(19) **United States**
(12) **Patent Application Publication**
Becking et al.

(10) **Pub. No.: US 2013/0123830 A1**
(43) **Pub. Date: May 16, 2013**

(54) **MULTIPLE LAYER FILAMENTARY DEVICES FOR TREATMENT OF VASCULAR DEFECTS**

(71) Applicants: **Frank P. Becking**, Palo Alto, CA (US);
Arturo S. Rosqueta, San Jose, CA (US);
Siddharth Loganathan, Santa Clara, CA (US)

(72) Inventors: **Frank P. Becking**, Palo Alto, CA (US);
Arturo S. Rosqueta, San Jose, CA (US);
Siddharth Loganathan, Santa Clara, CA (US)

(73) Assignee: **Nfocus Neuromedical, Inc.**, Menlo Park, CA (US)

(21) Appl. No.: **13/664,348**

(22) Filed: **Oct. 30, 2012**

Related U.S. Application Data

(63) Continuation of application No. 13/048,648, filed on Mar. 15, 2011, which is a continuation of application No. 12/427,620, filed on Apr. 21, 2009, now Pat. No. 8,142,456.

(60) Provisional application No. 61/046,594, filed on Apr. 21, 2008, provisional application No. 61/046,670, filed on Apr. 21, 2008, provisional application No. 61/083,957, filed on Jul. 28, 2008, provisional application No. 61/083,961, filed on Jul. 28, 2008, provisional application No. 61/145,097, filed on Jan. 15, 2009.

Publication Classification

(51) **Int. Cl.**
A61B 17/12 (2006.01)
(52) **U.S. Cl.**
CPC **A61B 17/12113** (2013.01)
USPC **606/191**

(57) **ABSTRACT**

Embolic implants, delivery systems and methods of manufacture and delivery are disclosed. The devices can be used for aneurysm treatment and/or parent vessel occlusion. Implant designs offer low profile compressibility for delivery to neurovasculature, while maintaining other necessary features such as density for occlusion purposes and desirable radial strength characteristics.

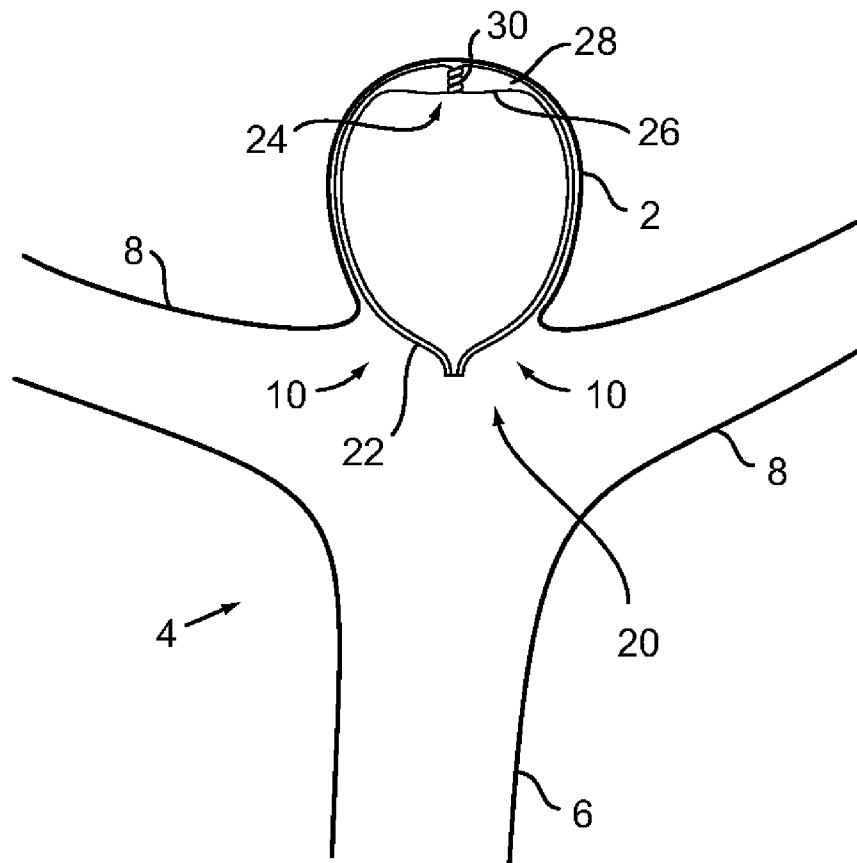

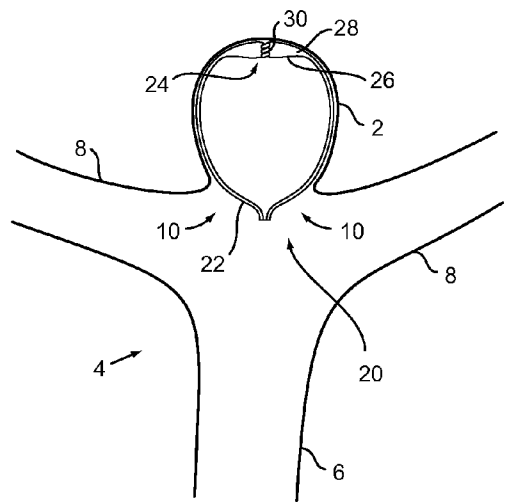

Fig. 1A

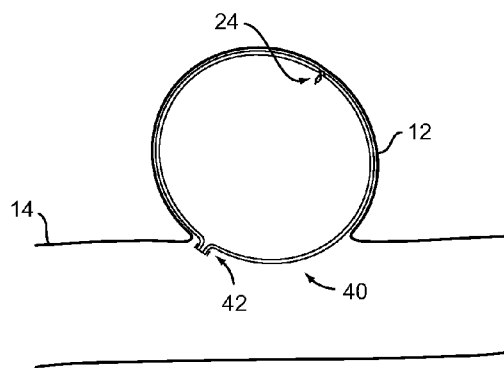

Fig. 1B

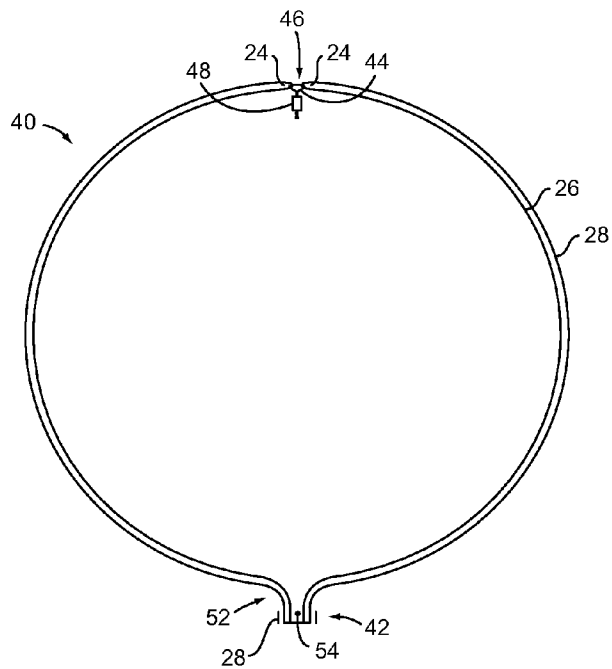

Fig. 2

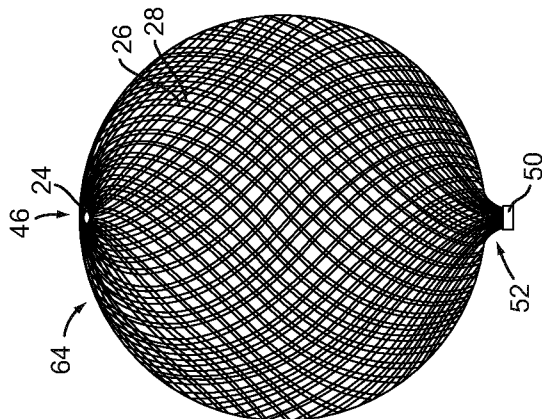

Fig. 3C

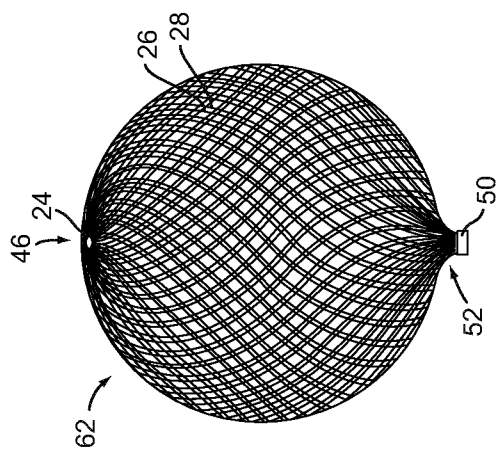

Fig. 3B

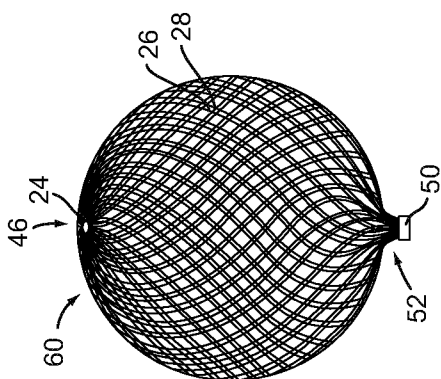

Fig. 3A

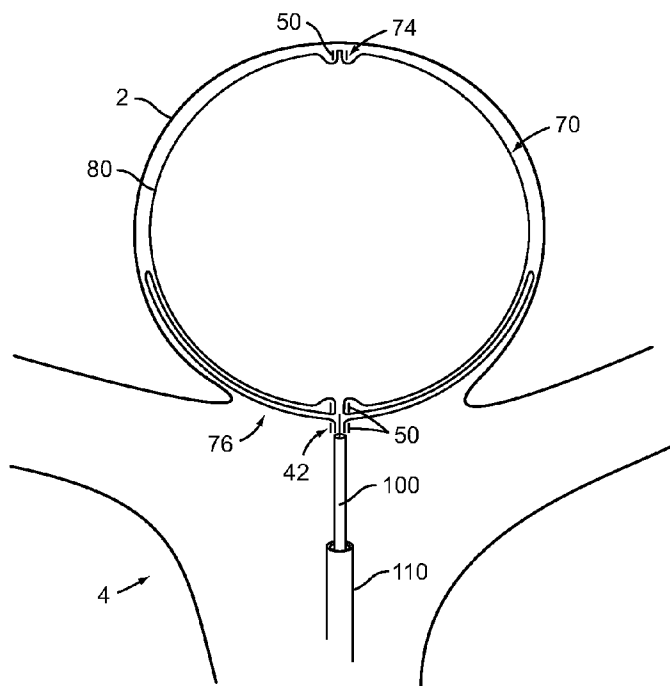

Fig. 4A

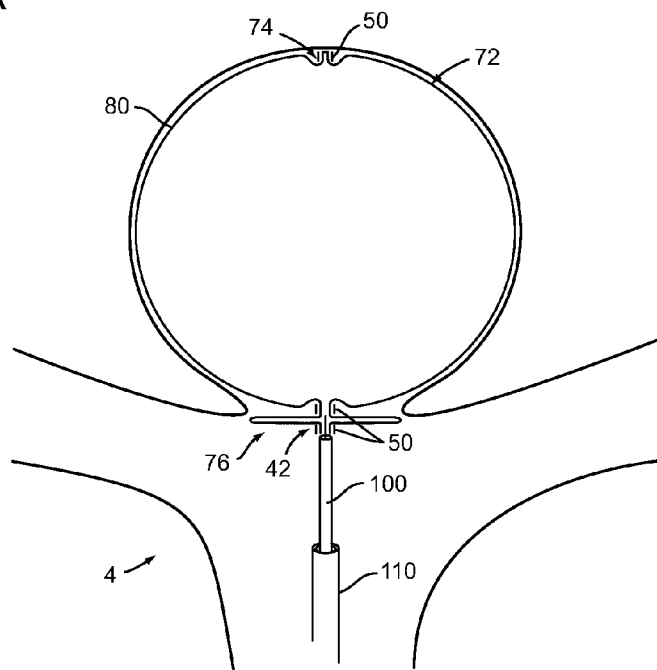

Fig. 4B

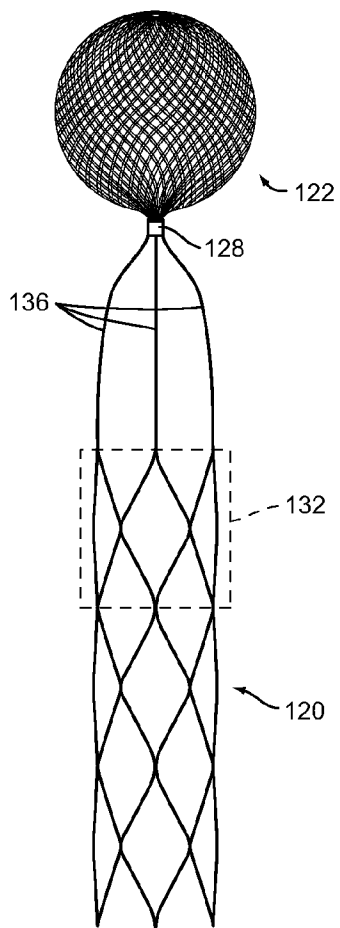

Fig. 5A

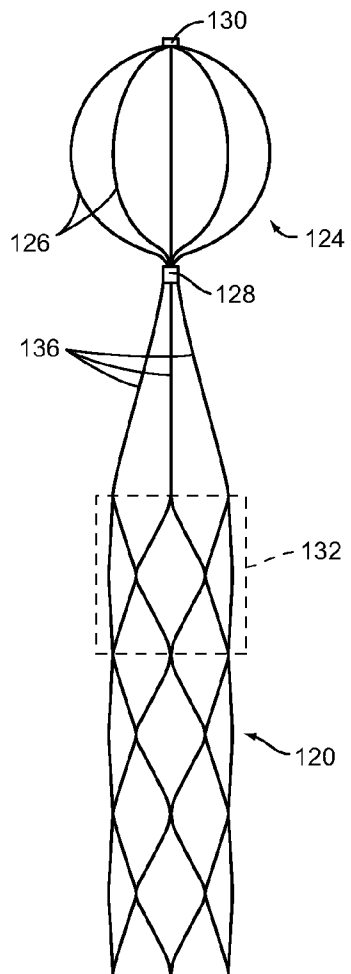

Fig. 5B

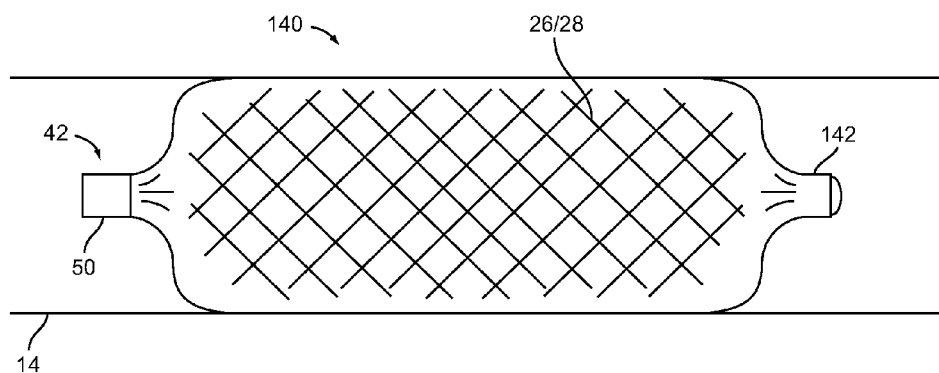

Fig. 6

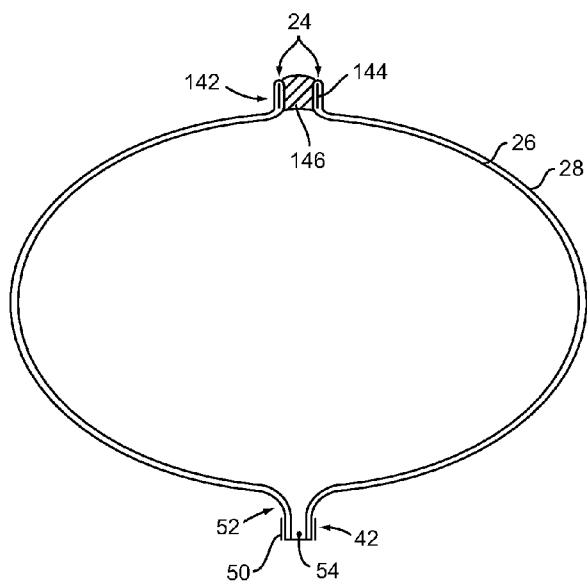

Fig. 7

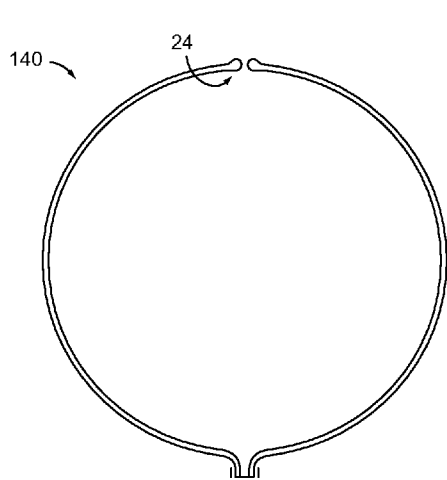

Fig. 8A

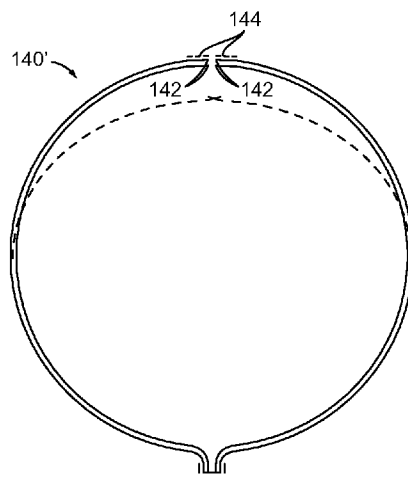

Fig. 8B

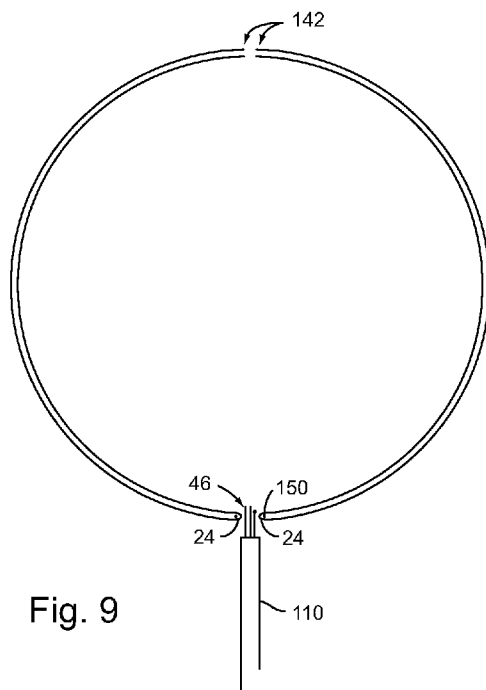

Fig. 9

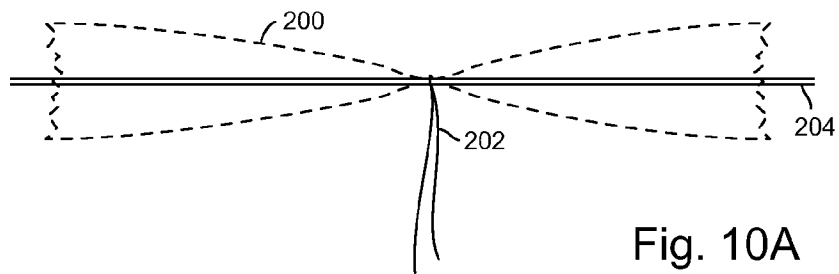

Fig. 10A

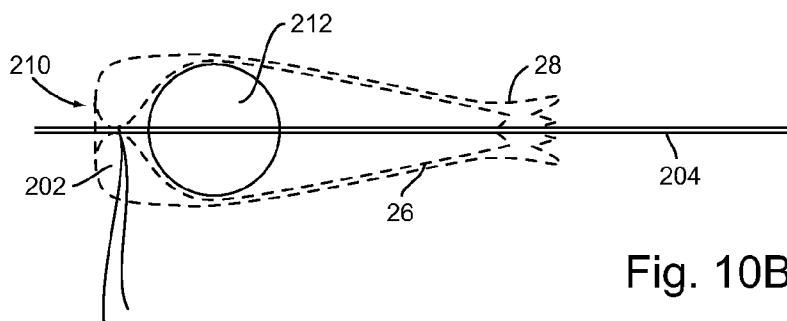

Fig. 10B

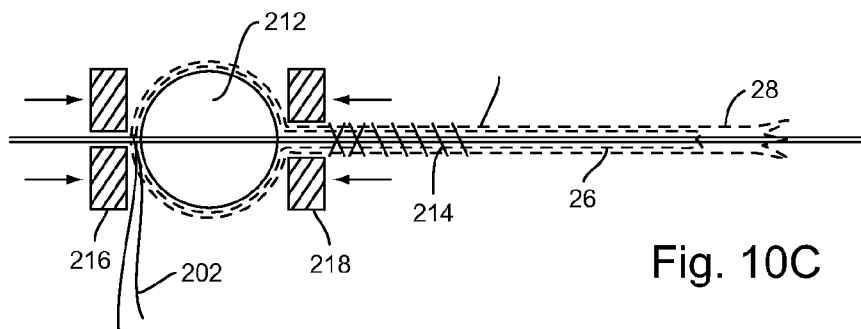

Fig. 10C

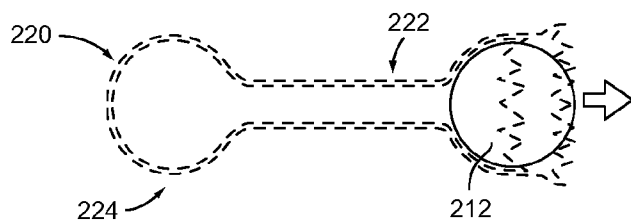

Fig. 10D

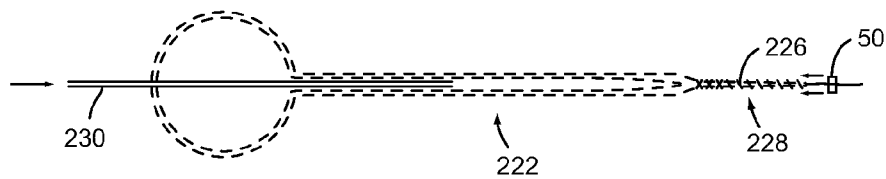

Fig. 10E

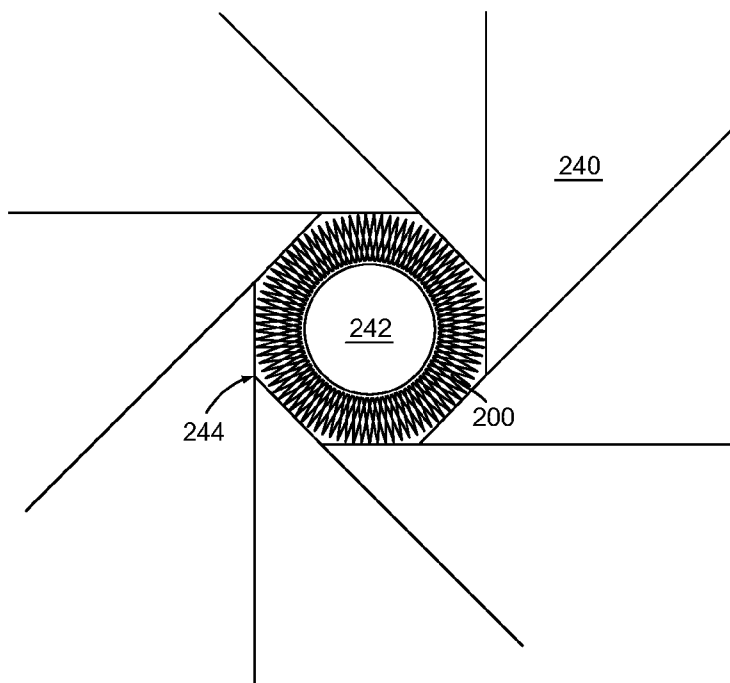

Fig. 11A

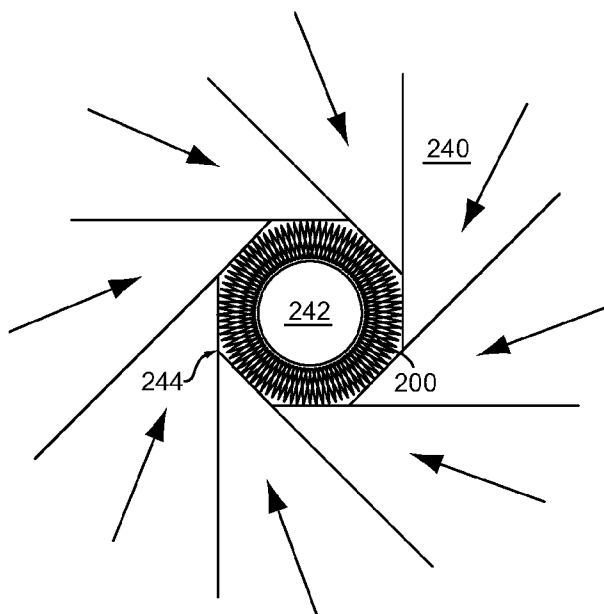

Fig. 11B

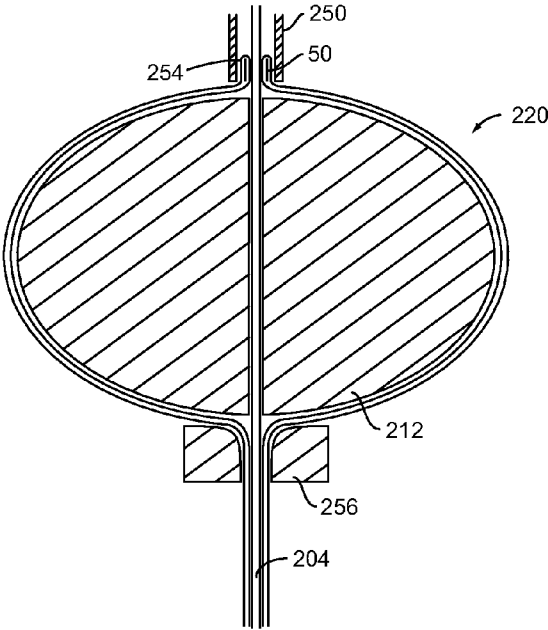

Fig. 12A

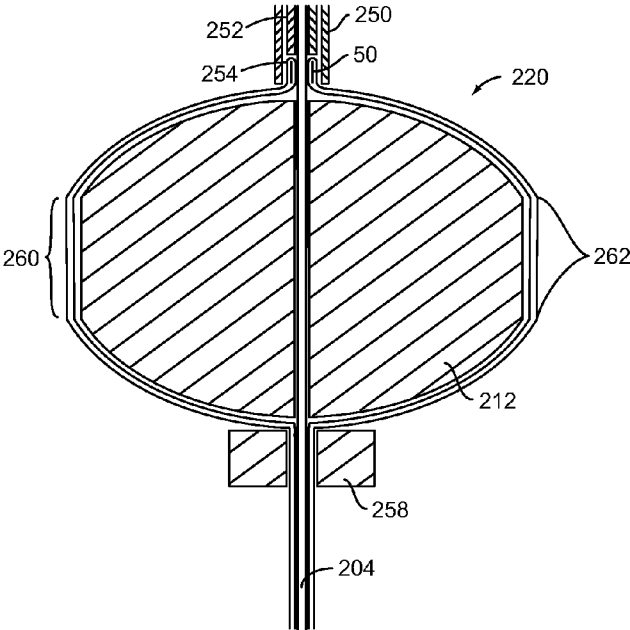

Fig. 12B

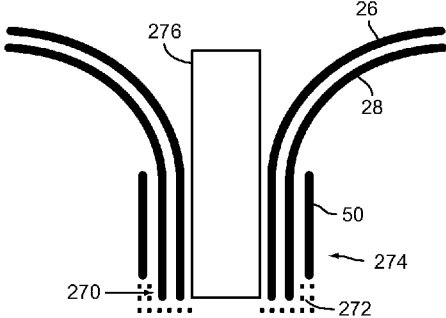

Fig. 13A

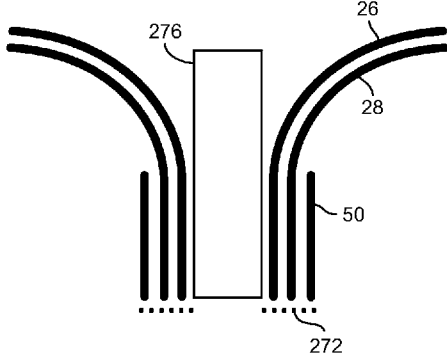

Fig. 13B

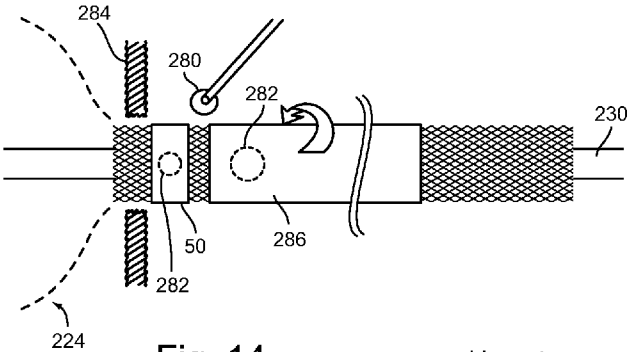

Fig. 14

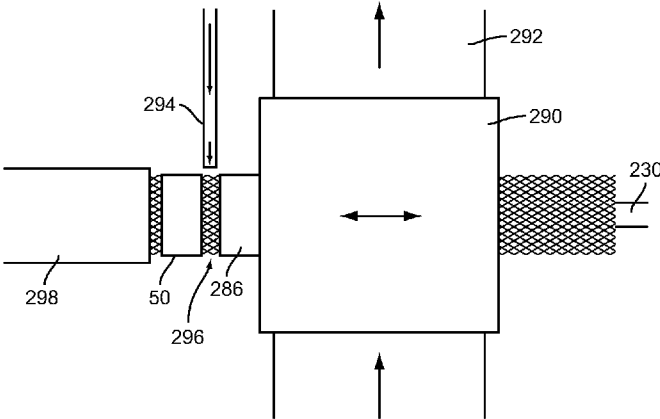

Fig. 15

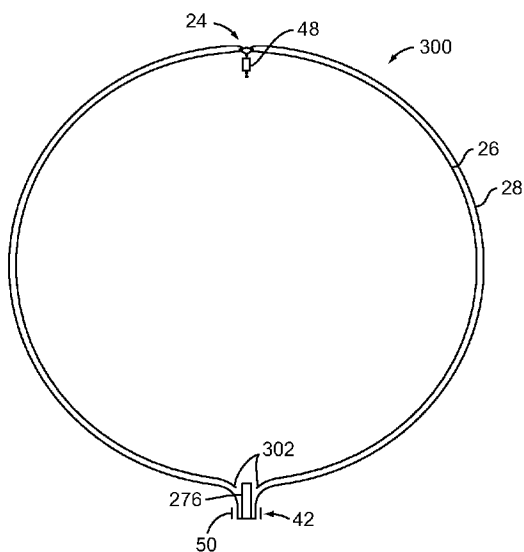

Fig. 16

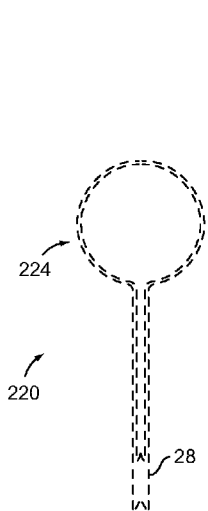

Fig. 17A

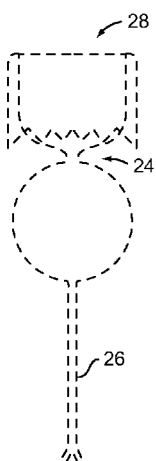

Fig. 17B

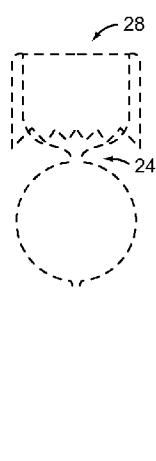

Fig. 17C

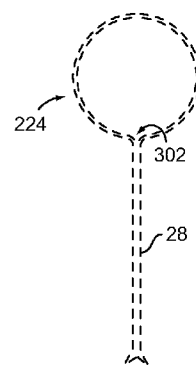

Fig. 17D

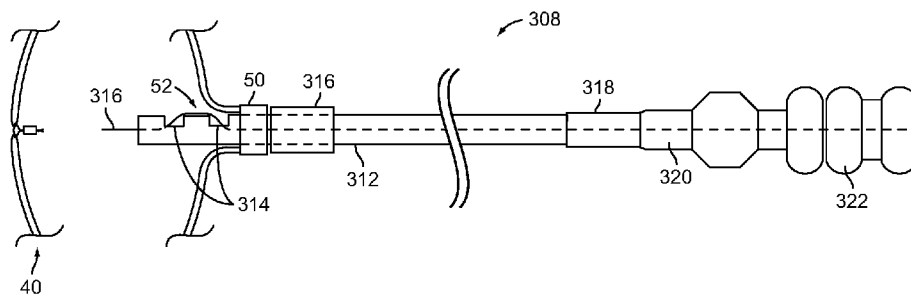

Fig. 18

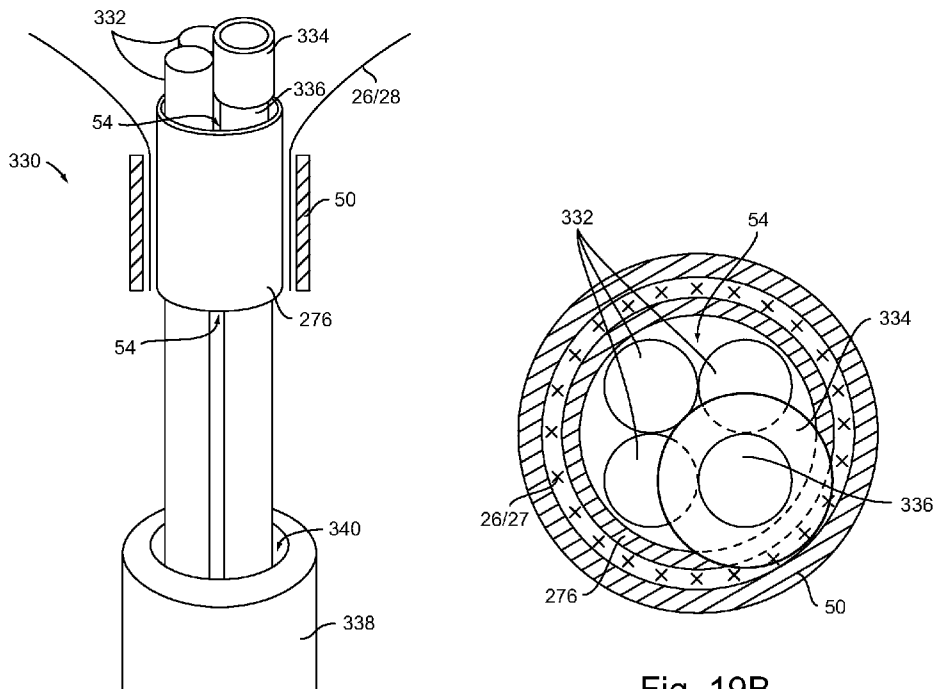

Fig. 19A

Fig. 19B

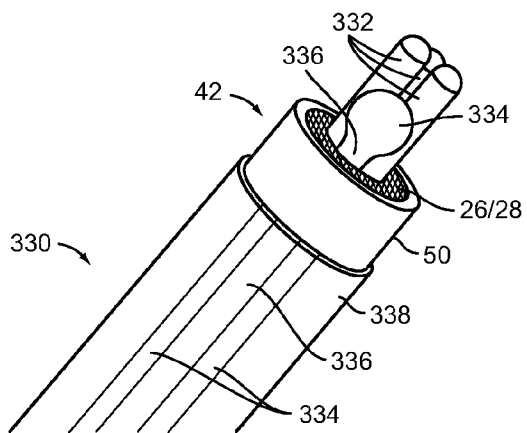

Fig. 20A

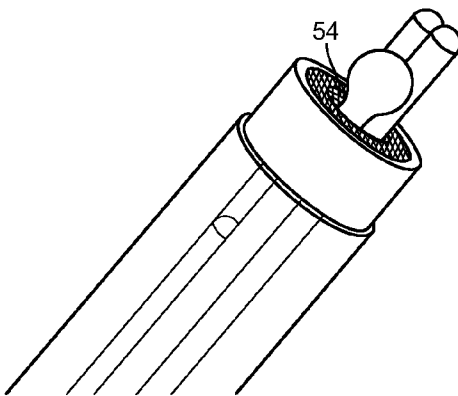

Fig. 20B

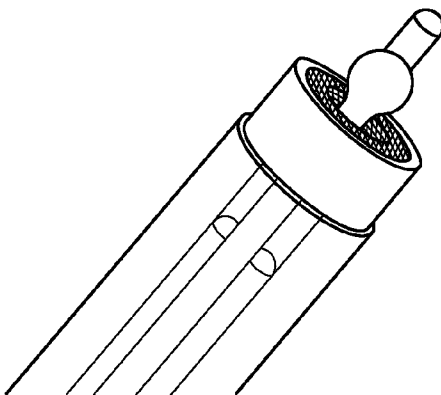

Fig. 20C

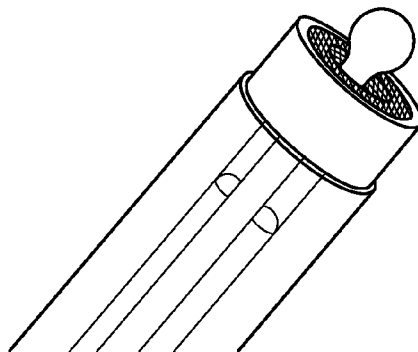

Fig. 20D

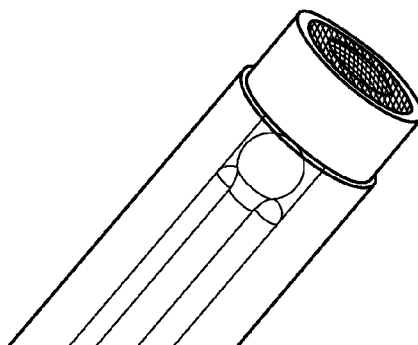

Fig. 20E

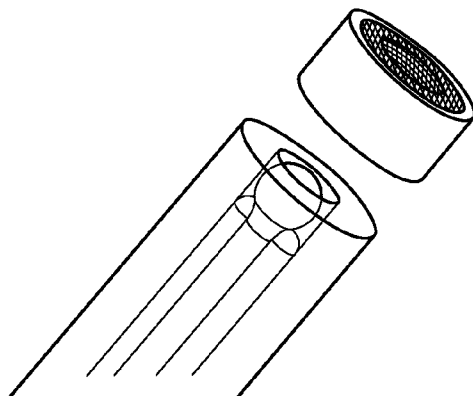

Fig. 20F

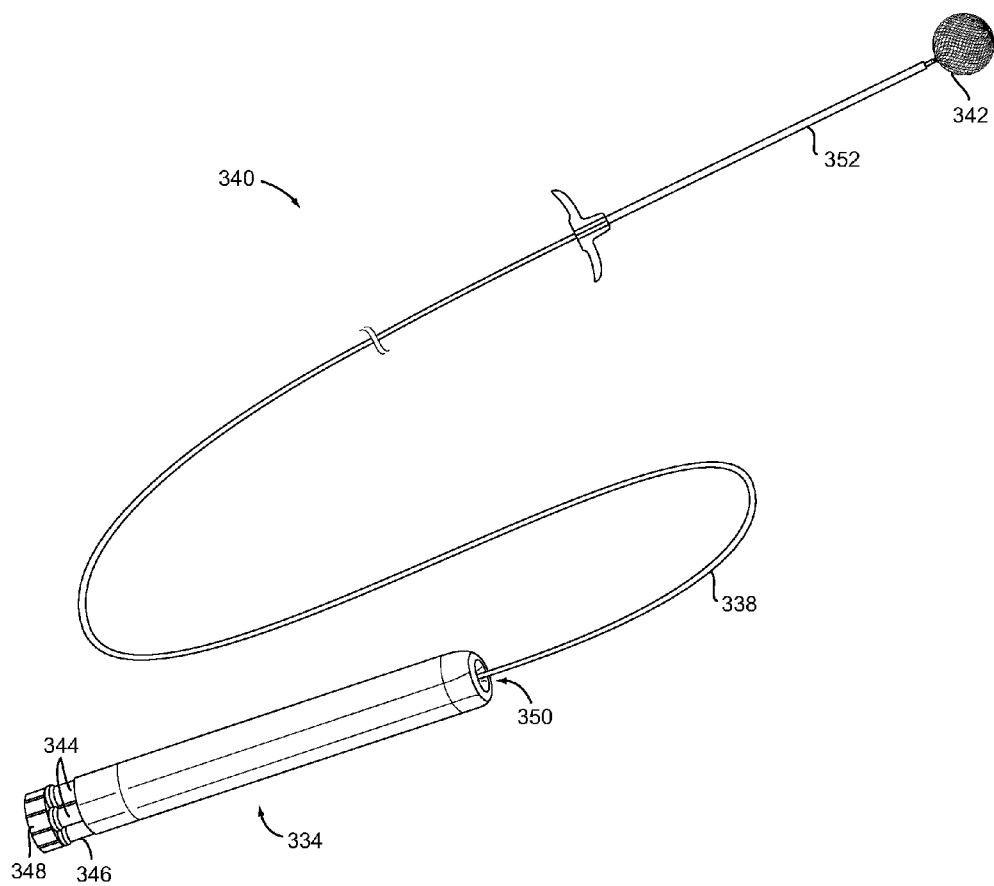

Fig. 21

MULTIPLE LAYER FILAMENTARY DEVICES FOR TREATMENT OF VASCULAR DEFECTS

RELATED APPLICATIONS

[0001] This application is a continuation of U.S. patent application Ser. No. 13/048,648, filed Mar. 15, 2011, which is a continuation of U.S. patent application Ser. No. 12/427,620, filed Apr. 21, 2009, which claims priority to U.S. Patent Application Ser. No. 61/046,594, filed Apr. 21, 2008, U.S. Patent Application Ser. No. 61/046,670, filed Apr. 21, 2008, U.S. Patent Application Ser. No. 61/083,957, filed Jul. 28, 2008, U.S. Patent Application Ser. No. 61/083,961, filed Jul. 28, 2008 and U.S. Patent Application Ser. No. 61/145,097, filed Jan. 15, 2009, all of which are incorporated herein by reference in their entirety.

BACKGROUND

[0002] Mainstream clinical practice in endovascular treatment of intracranial aneurysms has changed little since the 1990's when vasoocclusive coil use became widespread. Certainly, improved catheters and other auxiliary devices (e.g., stents) have helped make coiling procedures safer and/or more effective. However, the art in achieving adequate and appropriate aneurysm coil packing is best accomplished by the most highly skilled physicians.

[0003] Where practicable, aneurysm exclusion by cover-type devices (e.g., as described in U.S. patent application Ser. No. 12/397,123 to the assignee hereof) may be preferred. Certain other groups are attempting to shift the paradigm away from intra-aneurysm coil packing to achieve embolization via deployment of an extra-aneurysm flow disruptor/diverter stent in the parent vessel. These densely braided devices and/or multiple braid devices layered upon one another are placed in the parent vessel across the neck of an aneurysm with the intent to alter hemodynamics so as to effect embolization.

[0004] These WALLSTENT-like devices are best suited for placement across sidewall aneurysms. Yet, terminal aneurysms (e.g., bifurcation aneurysms) are estimated by some to make-up between about 60 and 80% of all aneurysm occurrences. By most optimistic count, only about 40% of intracranial aneurysms can be treated using the referenced stent-like devices.

[0005] Numerous other devices have been conceived in effort to address terminal aneurysms. Complicated and/or impracticable deployment is common to many. Others simply serve as adjunctive to coils or liquid embolic agents. In these latter examples, procedures may become even more complicated and require even greater physician skill than a standard coiling procedure.

[0006] A simpler, yet promising solution is proposed in PCT/US 2007/0076232 to Dieck, et al. A braided/mesh conical member is described for diverting blood flow from the aneurysm neck. A base of the device is set inside the aneurysm while a flow diverter portion extends into the parent vessel to direct blood flow toward adjacent side branches and away from the aneurysm. The implant may be positioned within the aneurysm as a stand-alone device or be supported by a connected stent-like body.

[0007] U.S. Pat. Nos. 6,168,622 and 6,506,204 to Mazzocchi, et al. discloses another type of braided flow disruptor set at least partly within an aneurysm. A bulbous portion is adapted to fit within the aneurysm dome and is anchored on

the outside by a neck-covering flap. Given the manner in which bifurcation aneurysms often incorporate branch vessel anatomy, such a patch would often interfere with and/or "flap" free raising significant issues of potentially pathological thrombus formation within the parent vessel.

[0008] Implants of the present invention address shortcomings of each of the above-referenced devices. As such, the subject implants (as well as their associated delivery systems) offer potential to advance the state of the art in endovascular treatment of vascular malformations, including aneurysms.

SUMMARY OF THE INVENTION

[0009] The present invention is directed to wire braid ball implants for occluding blood flow at endovascular sites. Delivery systems and methods of making the balls are also described. The balls are useful for treating neurovascular defects. One use is in intracranial aneurysm embolization/occlusion and another in parent vessel occlusion (PVO) or sacrifice.

[0010] Generally speaking, the subject vascular implants are braided devices using a combination of bio-stable materials selected from Stainless Steel, Cobalt Chromium, Nitinol, Titanium, Titanium-alloys, Zirconium and Zirconium alloys, PET (or another suture material) and medical-grade adhesive. The density of the device is paramount in applications where braid itself is intended to affect blood flow, allowing thrombosis within a volume formed by the ball to occlude a site. As such, high density braid/mesh is typically required. Namely, braid having at least about 48 ends, typically set at about 90 degrees or greater, in diameters from about 4 to about 8 mm may be employed. At larger diameters (e.g., about 6 mm to 12 mm or more), more wire ends (e.g., common multiples of 64, 72, 96, 128, 144) may be employed in forming the balls. Still higher typical wire counts may be employed. Either one of commercially available 192 and 288 carrier standard braiders may be employed. Moreover, 3-D braiding technology (such services are provided by 3Tex, Inc.) may be employed in forming the braid matrix from which the balls are formed. In addition, any combination of wire diameter, wire count, braid angle, and per-inch crossings can be used to make braid in order to configure an embolic and blood flow occlusive device deemed appropriate for a particular vascular site.

[0011] A range of wire sizes or combination of wire sizes may be employed, typically ranging from about 0.0008 to about 0.0015 inch, and up to about 0.003 inches depending on desired delivery profile (which is typically desired to be less than about 0.050 inches—at least for neurovascular indications—and more generally up to about 0.070 for peripheral PVO indications). A single braid tube may have all wires the same diameter, or may have some wires of a slightly thicker diameter to impart additional strength to the braid layer. For example, half the wires of a 96 wire tube (i.e., 48 ends) can be e.g. 0.001" diameter and the other half of the wires can be e.g. 0.0015" diameter. In which case, the two wire sizes would typically be interlaced uniformly in making the braid. The thicker wires impart greater strength to the braid without significantly increasing the device delivery profile, with the thinner wires offering some strength while filling-out the braid matrix density.

[0012] The wire is preferably NiTi alloy that is superelastic at body temperature. The metal may be a binary alloy or a ternary alloy to provide additional radiopacity. Alternatively, radiopaque platinum fibers may be included in the braid, or

the wire may comprise platinum or gold core Nitinol DFT. Otherwise, hubs, bands or wraps (preferably Pt) used to secure the braid wire (at either or both distal and proximal ends, and also in between caps where appropriate) may serve as the sole radiopaque feature(s).

[0013] To improve implant wire corrosion resistance and/or biocompatibility after heat setting shape, the implants may be etched in "AYA" Sulfamic Acid solution, then passivated in Nitric acid solution. Alternatively or additionally, pre-etched and/or polished wire may be employed in braiding the implant matrix. Shape setting the braid in the implant shape may be performed in an oven/furnace, a fluidized bath or salt pot. All such processing is within ken of those with ordinary skill in the art.

[0014] Especially after heatsetting the shape, the wire may be coated with an agent for promoting a desired biological effect. For example, wire can be coated with a thrombogenic or an endothelization agent, or other agent capable of promoting a desired biological process at the target site. The braid balls may also be partially or fully coated on the exterior (e.g., with coating such as urethane) to increase the occlusive effect of the ball, provided the coating does not cause the delivery profile of the final device to exceed allowed limits. Hydrogel coating also offers an appealing option, such as a hydrogel-based polymer network capable of entrapping therapeutic agents as described in U.S. Pat. No. 6,905,700 to Won et al.

[0015] Likewise, while the balls advantageously comprise Nitinol braid, the braid may instead comprise polymer—especially high strength biodegradable polymer such as MX-2 (MAX-Prene), synthetic absorbable monofilament (90/10 Glycolide/L-Lactide) and/or G-2 (Glycoprene), synthetic absorbable monofilament (Glycolide (PGA), ϵ -Caprolactone (PCL), Trimethylene Carbonate (TMC) Copolymer) that is heat set into shape (e.g., at 110 degrees centigrade for an hour).

[0016] Deliverability of the subject implants to certain neurovascular sites (e.g., distal intercranial aneurysms) often requires that they be compressible to pass through a catheter sized for navigating the narrow and tortuous vessels of the brain. Standard neurovascular catheters suitable for such use have 0.021" and 0.027" lumen diameters. Especially for higher wire count balls 0.027" ID (e.g., Cordis Mass Transit Boston Scientific Renegade HI-FLO) or larger (e.g., 0.044" ID Concentric Merci Distal Access Catheter) commercially available micro catheters may be preferred. For devices adapted to address PVO indications in which higher wire counts and/or larger wire diameters are used to ensure anchoring, the implants may require 5 and/or 6 Fr guide catheters for delivery.

[0017] In any of the configurations described, the devices may comprise high-density Nitinol braid that is folded/doubled-back upon itself and heatset to provide an open body having two adjacent layers forming an even denser matrix to occlude blood flow. The folded-back (inverted or everted) section may be closed to define a distal end of the device where a radiopaque feature may be located. At the opposite side of the implant, braid filaments are held in a hub including at least an outer band.

[0018] A port within the hub can receive component(s) of an optional detachable pusher. Alternatively, the implant can be deployed through a catheter using a simple pusher. Braid filaments within the hub(s) may be welded to each other and/or the band. Alternatively, the braid and hub(s) may be secured using biocompatible adhesive.

[0019] In a relaxed state, the implants define an open, preferably rounded, volume. In a delivery catheter, they compress into a substantially cylindrical body. When deployed at a treatment site, they expand to abut surrounding tissue and occlude flow in a clinically relevant timeframe.

[0020] Use of a detachable pusher allows for deploying a device (e.g., in an aneurysm) and checking fit. Deployed in an aneurysm to occlude the aneurysm at its neck, the implant device largely assumes the shape of the aneurysm, with the proximal hub and closely adjacent braid material outside the neck. To achieve such fit, the implants are provided in a range of sizes. These may progress in 0.5 mm to 1 mm diameter increments. For aneurysm treatment at bifurcations, it may also be desirable if the ball (at least in its delivered configuration) assumes a tear-drop shape to assist in a flow-divider/diverter type function as described in Dieck, et al., referenced above.

[0021] Should the selected implant not fit as desired, however, it can simply be withdrawn back into the delivery catheter. If desired fit is achieved (with the first implant or a replacement) as confirmed by medical imaging, the implant is released.

[0022] An electrolytically-releasable GDC-type joint can be used hold the implant secure to the pusher until release. Details regarding suitable electrolytic detachment systems can be appreciated and applied to the current system as taught in U.S. Pat. No. 5,122,136 to Guglielmi and continuing applications thereof—all of which are herein incorporated by reference. Another electrically-powered detachment approach employs a meltable fiber or suture junction connecting the implant to the delivery pusher/guide. In such a system, a polymeric core may be configured with helically wound conducting ribbons held to the core. Upon application of voltage, sufficient current is conveyed through the ribbons to a wire bridge connecting them. Heat generated along the bridge, optionally NiChrome wire, severs the suture that is tied onto or running adjacent to the bridge in order to release the implant. Further details of a suitable suture-melt detachment systems are described in the incorporated provisional applications.

[0023] Yet, mechanical detachment systems may be more preferred. An aspect of the present invention involves pushers in which at least one member provides mechanical interference at/with the implant hub port to releasably lock the implant onto the pusher. In one approach, a wire or ribbon exiting an extension of the pusher threaded through the port produces such interference until it is withdrawn. In another example, a plurality of wires/ribbons are received through the port. One or more (typically two or three) of these wires extend through a pusher catheter body to a proximal handle interface. A final "anchor" wire received through the port may also extend to the handle. The anchor wire includes a head sized to exit the hub port only after the other "control" wires are cleared therefrom. The head is preferably formed by laser or plasma heating/melting. The handle provides a user interface to first remove the control wires, and then (optionally) also pull the final anchor wire.

[0024] To assist in implant recapture should in not be released, a smooth lead-in/trumpet shaped recapture profile may be provided between the hub and main body of the implant. In another approach relevant in a two-layer implant, no such profile is provided. Rather only the outer of braid layer is secured within the hub, and the inner layer "floats". In

this way, only the outer layer must be straightened relative to the hub to retrieve the ball within the catheter/sheath, with the inner layer riding along.

[0025] In order to permit such action, the braid matrix must remain stable and interlocked. Accordingly, when feasible, a one-over-one braid pattern will be preferred. In addition, the braid should be trimmed adjacent the hub where the hub-secured braid is most dense. So configured, the outer braid both serves as a guide and is of such density to prevent loose ends of the inner layer from poking through. Whereas a floating-layer type ball implant would typically only be used for an aneurysm indication due to reduced radial strength, the recapture profile may be used on either an implant intended for aneurysm or PVO use.

[0026] Recapture features aside, when deployed in a vessel for use in parent vessel occlusion, the subject implant is “sausage” shaped. For such purposes, it may be desirable that the compressed length of the ball is minimized relative to its diameter. Proximal and/or distal ends of the ball may be flattened or flatter (such that the ball is more “donut” shaped) for this purpose.

[0027] Oversizing the device relative to the vessel provides adequate radial force to anchor its position against blood flow/pressure. To generate more anchoring force within a vessel for a PVO-dedicated implant (i.e., of a given deployed length), the ball may be formed in a shape having an elliptical cross-section. To offer further improved vessel anchoring, a cylindrical waist may be incorporated in the shape. Edges formed will concentrate stresses on the vessel wall in some cases to improve anchoring. Yet, the bulk shape allows the implant to work within a wide range of vessel sizes. Indeed, one size may fit a wide range of vessel diameters (e.g., a 10 mm ball suitable for 3-5 mm vessels, etc.).

[0028] In either type of implant (i.e., aneurysm or PVO), an advantageous construction involves folding or doubling-back the braid during manufacture to produce a two-layer matrix. A medial crease or fold in the braid is formed that is used in defining one end of the implant.

[0029] The fold may be pre-set in the braid or formed when fixturing the braid for shape setting. In the former case, the bend is pre-set by heatsetting the braid when confined in a tight tubular shape (e.g., by a crimper or at least partially within a hypotube). In the latter case, the braid is tied with suture at a point, a form is inserted in the open end of the braid tube and the braid is stretched, or positioned, over the form with the folded section under compression. When heated to set the shape, the suture burns away as the compression force sets the fold at a minimal radius.

[0030] The fold itself proves useful in a number of ways. In one variation of the invention, the folded section provides an atraumatic end to the implant. The folded section can be left open, or tied closed by a suture, wire (or other material) loop. If not radiopaque itself, the tie may also hold a marker band (knotted, glued or crimped on). If such a marker is provided, it may advantageously be suspended adjacent the top/distal end of the ball within the interior volume.

[0031] Either way, upon compression to a delivery profile, the implant body basically pivots (rather than bends) at the fold, thus minimizing in-catheter/sheath forces. This improves device trackability as well as delivery and the ability to recapture if treatment with another size device is desirable.

[0032] In a PVO-specific implant, a marker band can be held between braid layers adjacent the medial fold. The band

is securely captured and “hidden” without presenting edges or other features. As such, the distal end of the device offers a smooth delivery/tracking profile without need to otherwise secure the band.

[0033] Utilized in any such fashion (i.e., open, tied or banded), joints and other delivery profile-increasing features are avoided at one end of the ball. As such, the fold offers constructional advantages (including improved manufacturability)—as well as reducing areas for failure where ends of the braid would otherwise need to be secured. Moreover, the doubled-over tubular stock achieves excellent density while ensuring consistent compression and shape-recovery performance since the layers are well matched. So-matched, they extend/foreshorten to substantially an equal degree when exiting and (re)entering the catheter.

[0034] One variation of the invention takes advantage of the matched braid layers, and simply eliminates the fold by grinding or otherwise cutting it away after heatsetting (and, optionally, braid hub securement). So-prepared, the implant becomes more radially compliant as may be desirable for aneurysm treatment. And without any additional space taken-up by the bend in the filaments, the ball can be further compressed for delivery through the smallest microcatheters (for a given braid density) to achieve access to more distal treatment sites.

[0035] Another variation of the invention may or may not be constructed using a folded-over approach. To achieve higher braid densities without stacking up additional layers having to fit within the microcatheter lumen, additional “cap” structures can be instead incorporated in the implant. For delivery, these features neck-down or compress in series. Yet, upon exit from the microcatheter, they recover to a position adjacent the main body of the implant.

[0036] The ball body and cap portions of the implant are typically constructed from a continuous section of braid. Intermediate marker sections may be provided between elements. A hub including a delivery system port is provided at the proximal end of the device.

[0037] The proximal caps of braid provide additional braid layers to the device at an end where occlusion of blood flow is critical. The proximal end of a ball placed in an aneurysm contacts the opening and neck of the aneurysm. To achieve greater flow occlusion, the braid caps can be single or double layer braid. One or more braid caps can be placed at the proximal end of the ball (i.e. a braid ball can have up to three braid caps, and more if feasible).

[0038] The braid caps do not function, and are not adapted to function, as anchors for the device. An anchor holds fast or checks motion of an object attached to it. To anchor something is to fix or fasten, or affix firmly an object. The balls implants are not anchored in the aneurysm or parent vessel using the braid caps. Rather, the braid caps are designed to either be adjacent the ball within an aneurysm or to fill only the neck region. In either case, the caps do not substantially engage vascular tissue adjacent the ball. They serve as occlusive elements that enhance the ball’s embolic potential.

[0039] As alluded to, two types of capped braid ball implants are provided. Caps adapted to fit only in the aneurysm neck are typically round (though they may be oval) and may be offered in a variety of sizes to fit different neck sizes just as the ball portion of the implant is offered in different sizes. In other words, across a whole line of implants, each of the cap size and ball size parameters may be varied.

[0040] The caps adapted to fit in an aneurysm adjacent the ball portion of the implant are larger and shaped to conform to the ball-shaped body. Their delivery requires either compressing the ball portion of the implant within the aneurysm and deploying the cap therein, or deploying the cap outside the aneurysm and pushing it into the aneurysm in a deployed state.

[0041] Delivery of the devices with the neck-filling cap(s) or disk(s) is performed substantially the same as braid balls without such feature(s) with the exception that the delivery catheter is withdrawn further to expose the cap(s) or the catheter is stationed outside the aneurysm neck (vs. at the neck) and the implant extruded therefrom. Of course, some combination of such activity may alternatively be employed.

[0042] In any case, if desired fit is achieved, the implant is released. Otherwise, the implant is pulled into the delivery catheter from the proximal hub. The one or more caps compress to the linear profile of the delivery/retrieval sheath, followed by the ball portion.

[0043] In yet another variation of the invention, a braid-ball is used in conjunction with a stent. The ball may be attached to a stent, with them delivered together. Alternatively, a frame or cage may be provided at the end of a stent into which the a braid-ball is delivered after the stent is in place. In either case, the ball and/or frame may be sized to fill substantially all of an aneurysm or only fill the neck. Either way, the stent will serve as an anchor to prevent the ball from migrating. The frame-plus-ball solution offers certain advantages in terms of staged deliverability, whereas the ball-topped stent offers a one-shot solution achievable in a single delivery. In each example, the stent may be either self-expanding (e.g., comprising super-elastic Nitinol) or balloon-expandable (e.g., comprising stainless steel and mounted on a PTCA-type balloon). Regardless, the braid-ball implant employed may be any one of those described in the present filing or those cross-referenced above.

[0044] The present invention includes the subject devices, kits in which they are included, methods of use and manufacture. A number of aspects of such manufacture are discussed above. More detailed discussion is presented in connection with the figures below.

BRIEF DESCRIPTION OF THE FIGURES

[0045] The figures provided herein are not necessarily drawn to scale, with some components and features are exaggerated for clarity. Of these:

[0046] FIGS. 1A and 1B are side-sectional views illustrating braid ball implant variations in bifurcation and side-wall aneurysm locations, respectively, in which a folded section in each implant provides an atraumatic tissue interface;

[0047] FIG. 2 is a blow-up view of the implant pictured in FIG. 1B;

[0048] FIGS. 3A-3C are perspective side views of a folded-section braid ball in progressively larger sizes;

[0049] FIGS. 4A and 4B are side-sectional views illustrating proximal-flap braid ball implant variations deployed within bifurcation aneurysm locations;

[0050] FIG. 5A is a side view of a stent-anchored version of a braid ball implant,

[0051] FIG. 5B is a side view a stent with a cage for receipt of a braid ball implant;

[0052] FIG. 6 is a side view illustrating a folded-section braid ball implant in a PVO application;

[0053] FIG. 7 is a side-sectional view of the implant in FIG. 6;

[0054] FIGS. 8A and 8B are side-sectional views of an implant shown in stages of manufacture;

[0055] FIG. 9 is a side sectional view of an implant in which the folded section is to be utilized at a proximal side of the device;

[0056] FIGS. 10A-10E are side views illustrating stages of a folded-section braid ball implant manufacture;

[0057] FIGS. 11A and 11B are end views diagrammatically illustrating a technique for presetting the shape of the implant fold;

[0058] FIGS. 12A and 12B are side sectional views illustrating folded-section braid ball implants with associated tooling for setting their shape;

[0059] FIGS. 13A and 13B are partial side-sectional views illustrating alternate braid/band affixation approaches;

[0060] FIG. 14 is a partial side-sectional view illustrating a hub-gluing approach;

[0061] FIG. 15 is a partial side view showing a hub-trimming approach;

[0062] FIG. 16 is a side-sectional view illustrating another folded-section braid ball implant variation;

[0063] FIGS. 17A-17D are side views illustrating stages of the FIG. 16 embodiment manufacture;

[0064] FIG. 18 is a side view of a delivery system variation suitable for use in the present invention;

[0065] FIG. 19A is a partial side-sectional view of a distal end of another delivery system variation suitable for use in the present invention;

[0066] FIG. 19B is an end view from within the implant of the system shown in FIG. 19A;

[0067] FIGS. 20A-20F are partial perspective views of implant detachment with a system constructed according to the approach shown in FIGS. 19A and 10B; and

[0068] FIG. 21 is a perspective view providing an overview of a treatment system according to the present invention.

[0069] Variations of the invention from the embodiments pictured are contemplated. Accordingly, depiction of aspects and elements of the invention in the figures is not intended to limit the scope of the invention.

DETAILED DESCRIPTION

[0070] Various exemplary embodiments of the invention are described below. Reference is made to these examples in a non-limiting sense. They are provided to illustrate more broadly applicable aspects of the present invention. Various changes may be made to the invention described and equivalents may be substituted without departing from the true spirit and scope of the invention. In addition, many modifications may be made to adapt a particular situation, material, composition of matter, process, process act(s) or step(s) to the objective(s), spirit or scope of the present invention. All such modifications are intended to be within the scope of the claims made herein.

[0071] Turning to FIG. 1A, it shows a first implant 20 according to the present invention. It is formed from tubular braid stock comprising a resilient material such as Nitinol, that defines an open volume (generally round, spherical, ovalar, heart-shaped, etc.) in an uncompressed/constrained state.

[0072] Implant 20 is set within an aneurysm sac 2 at a vascular bifurcation 4. It is delivered by access through the trunk vessel 8 (e.g., the basilar artery), preferably through a

commercially available microcatheter (not shown) with a delivery system as detailed below.

[0073] The size of the implant may be selected to fill and extend somewhat out the neck **10** of the aneurysm so the proximal end **22** of the device helps direct blood flow along the surface of the braid from which it is constructed to the branch vessels **8**. A distal end of the ball is dome-shaped adjacent a fold **24** in the braid resulting in a two-layer **26, 28** (inner and outer layer, respectively) construction at least where impacted by flow at the neck **10** of the aneurysm. As shown, one or more turns of a coil **30** (e.g., Pt wire) or a band (not shown) may provide a distal radiopaque feature to mark the location of the implant.

[0074] The fold **24** in the braid is set at a tighter radius in the implant **40** shown in FIG. 1B. Here, implant **40** is received within a sidewall aneurysm **12** off of a vessel **14**. A hub **42** of the implant is facing blood from and directed along the line of vascular access and delivery.

[0075] As more easily seen in FIG. 2, implant **40** includes a tie **44** closing an aperture **46** defined by the fold. A radiopaque (e.g., Pt) marker **48** is held by the tie. Such a marker does not interfere with compression of the implant for delivery. Radiographic visibility of the proximal end of the ball may be achieved by virtue of the density of the braid coming together, alone, or a radiopaque (e.g., Pt) band **50** may be added.

[0076] Tie **44** may comprise any biocompatible material including Stainless Steel, Titanium, Nitinol (possibly wire that is martensitic at body temperature—commonly referred to as “muscle wire”), suture, etc. An advantage of utilizing wire is that it may simply be twisted to secure its position, along with the marker. In any case, the tie filament should be thin (e.g., about 0.0015 inch diameter or less) if a minimum-radius fold is desired.

[0077] Another salient feature of implant **40** concerns the region adjacent hub **42**. Specifically, a flared or trumpet-shaped recapture profile **52** is set in the braid to aid in device recapture into the delivery catheter through which the device is advanced. An access port **54** is provided within the hub. This port accepts a delivery system interface. Delivery system construction as well as further optional details of the implant are provided below.

[0078] Of course, FIG. 2 shows a ball in an unconstrained condition. When set within an aneurysm, the implant will instead substantially conform to its shape (e.g., as shown in FIG. 1A). Generally, the implant will be oversized somewhat to exert some small load on the aneurysm wall to help maintain a stable position of the ball. However, the ball may be intentionally undersized, especially in a side-wall application (e.g., as shown in FIG. 1B) should it be desired that any hub feature is able to turn with the ball to trail with the blood flow.

[0079] Depending on the desired fit, the implant selected by the physician may turn out to be exactly the right size upon delivery due to variability of aneurysm morphology and/or limitations of medical imaging. It is then that the recapture profile is most useful by facilitating implant retrieval. The first implant can be discarded in favor of a second with a more appropriate size. FIGS. 3A-3C illustrate implants **60, 62** and **64** in a gradation of sizes. Naturally, the sizing interval may be varied. Likewise, the shape may be varied.

[0080] In the three examples provided, it is notable that a consistent pore size is maintained toward the center of the ball. Generally it will be desirable to minimize overall pore size. However, the density of the braid that can be achieved in braiding a given tube of braid stock is limited by its diameter

and wire size. Accordingly, each of the three balls shown is made of braid incorporating a different number of wires or “ends”. For example, the first implant **62** may be produced from folded-over 72-end material braided over a 6 mm diameter mandrel, the second implant **64** made of folded over 96-end braid from an 8 mm mandrel, and the third implant **64** made of folded-over 144-end braid made on a 10 mm mandrel. Alternately, the larger implants (i.e., those around 10 mm in diameter) may also be made of 96-end braid in order to maintain a lower crossing profile. Specifically, 0.027 inch catheter crossing profile can be achieved when using 96-end braid made of 0.001" diameter wire. Likewise, at the smaller end of the range (e.g., around 5 mm in diameter) 64-end braid may instead be selected to achieve 0.021 inch crossing profiles.

[0081] In any case, braid filaments are shown in pairs within these implant—one from each layer **26, 28**. While the organization of the braid is often more random, the double/dual layer construction—on average—results higher density that might be achieved with a single-layer implant due to limitations on braid density for a given starting diameter of braid.

[0082] The implants **70, 72** shown in FIGS. 4A and 4B, respectively, may also be dual layer construction. In which case, they would share their distal configuration with the previous implants **20/40/60**. As shown, they are single-layer devices in which the distal end takes the form of an inset hub **74**.

[0083] Either way, the implants include unique proximal-end configurations. In addition to a ball or bulbous portion **80**, each implant includes a flap **76, 78** intended to improve its blood flow disruption potential. Flap **76** included in implant **70** is intended for intra-aneurysmal use. To deliver it as shown, the ball or bulbous portion is first delivered into the aneurysm sac **2**. Then, that portion of the device is compressed while still mounted to pusher **100** to deploy the flap section therein. After final positioning is achieved as shown in FIG. 4a, then the pusher locking member(s) received within hub **42** are released. Finally, the pusher is withdrawn into the delivery catheter **110**. To assist in the delivery method, one or more additional radiopaque features (such as a band **50** at the proximal end of ball section **80**) may be provided so that deployment can be visualized at each stage.

[0084] The implant in FIG. 4B requires no such complication in delivery. Because flap **78** is of a size selected only to fill the aneurysm neck, it can be delivered straight-away. Still, intermediate radiopaque features may be desirable to confirm appropriate fit and/or deployment.

[0085] As pictured, the ball-and-disk variation of the implant shown in FIG. 4B may only be applicable to smaller-neck aneurysms as compared to the FIG. 4A “acorn” type variation. Generally, the size of the disc will not be significantly larger than the parent/trunk vessel **6** diameter and or that of the bifurcation region **4**. Otherwise, the vasculature will interfere with deployment. As such, the disk may be limited to about 2.5 to about 5 mm in diameter.

[0086] While understood better in the context of the implant manufacture steps below, flap **78** may be formed using a simple washer or plate over which the braid is heat set. Otherwise, the forming tool may be curved or dish-shaped so that flap **78** better follows the contour of the main implant body.

[0087] Flap **76** in the FIG. 4A variation will typically be formed using a concave/convex form in similar fashion. The size of this flap may vary. As shown, its outer extent is roughly

the same diameter of the ball portion **80** of the device. It may be smaller and/or cover a lesser extent of the proximal side of implant **70**. Generally, flap **70** will cover at least about a third and as much as one-half of body **80**. In this way, adequate neck coverage is better insured when employed to treat wide-neck aneurysms.

[0088] FIG. **5A** is a side view of a stent-anchored version of a braid ball implant. Stent **120** is sized to anchor in the trunk vessel in treating a terminal aneurysm. This way, the ball portion **122** may be sized only to fill the neck of the aneurysm instead of its entire volume. Such an approach may be especially useful for less regularly shaped aneurysms. The device in FIG. **5B** is used in a similar fashion, except that a braid-ball implant is introduced and held by a frame or cage **124**, after the stent section is set in place.

[0089] The frame may comprise a plurality of individual wires **126** secured to a hub **128** of the stent at a proximal end and another hub or platten **130** at the distal end. In another variation, the wires making up the frame are cut from the same tube as the stent cells and any included hub. They may terminate at a distal end within a hub, be swaged within a radiopaque band, welded together, secured by adhesive, or attached by some other means. In any case, they are typically (though not necessarily) attached to form a closed frame. Still, an open frame is contemplated—especially one in which the wires hook backwards (i.e., proximally) to help “catch” the ball when emplaced.

[0090] These devices (i.e., those illustrated in FIGS. **5A** and **5B**) are delivered employing standard techniques, except that “anti-jump”/retrieval features may be incorporated into the stent section. Regardless, at least one row of stent cells **132** is provided in the stent to effect a minimum level of anchoring; however, as many as five or more may be employed—with or without any special delivery anti-jump/control features.

[0091] While the stents advantageously include three support extensions **134** for the ball or ball cage, more or fewer may be employed. However, the use of three offers the minimal stable structure available. And where they come together, they operate much like a universal joint to help end-mounted ball/frame successfully interface with the aneurysm to be treated.

[0092] FIG. **6** illustrates an altogether different use of the subject implants. Namely, an implant **140** is deployed in a vessel (vs. adjacent a vessel within an aneurysm) to occlude flow. As referenced above, for PVO use the distal end of the ball may include a nub or nipple **142**. Indeed, such a feature is advantageous in a construction as illustrated in FIG. **7**.

[0093] In this side-sectional view, the braid matrix is shown inverted (or everted) at fold **24**. A band **144** is set between the inner and outer braid layers. The band closes the end and serves as a marker (especially when it comprises Pt). An adhesive compound **146** (e.g., LOCTITE **3311** or **4014**) may be used to fill any residual lumen within the fold aperture. As with the other implants (including those in FIGS. **4A** and **4B**) the implant may include a recapture profile section **52** at its proximal end, adjacent the hub **42**. Likewise, it may include a hub port **54**.

[0094] Otherwise, both ends of the implant may be closed/plugged with an adhesive or otherwise. Without a delivery system access port, the implant may be delivered using a simple pusher (vs. being fully retrievable and/or repositionable). So-configured, no proximal hub is required either. Indeed, the braid may simply be trimmed and shape set to

come together and/or be secured by welding, adhesive or otherwise at the proximal end.

[0095] Another optional aspect of the invention is illustrated in FIGS. **8A** and **8B**. Namely, a folded layer implant **140** is first formed without taking steps to minimize the bend radius at the braid fold **24**. While still usable, it may instead be desired to trim off the folded layer to produce a modified implant **140'** as shown in FIG. **8B**. Doing so eliminates the bulk, and also changes the implants delivery properties as may be desirable in certain circumstances. The implant becomes more radially compliant and able to fit a wider range of aneurysm sizes because ends **142** of the braid can pass by one another rather than bottoming-out. As such, the same implant **140'** can fill a smaller volume without necessarily extending from the neck of the aneurysm as indicated by dashed in FIG. **8B**.

[0096] In any case, because of the original construction technique utilizing one tube of braid and folding it over the produce two layers, the (now-separated) layers are well matched to predictably expand and contract. Moreover, once any profile-limiting bend are removed (e.g., by cutting, grinding, etc.) the layers can be reconnected if the adjustability feature described above is not desired. A urethane coating layer **144** or other adhesive (advantageously including radiopaque Barium or Tantalum powder) may be used locally to accomplish such action without resulting increase in delivery profile.

[0097] Still, maintaining the fold in an implant offers numerous advantages in other circumstances—especially when it is formed in such a manner that minimizes wire bend radius/profile. Namely, implants including the fold may offer better size integrity and radial force in circumstances when desired, eliminate any loose fibers at an end of the implant without further processing (such as by polymer application), provide a pocket for a marker and/or tie to suspend a marker, etc.

[0098] Moreover, it is to be recognized that the folded end of the implant will not necessarily be set at the distal end of the device. Rather, the folded section **24** may be utilized at a proximal side as shown in FIG. **9**. And the aperture **46** formed by the folded section (when held by a ring, band or tie **150**) provide a delivery system **110** interface. The opposite end of the implant may have an inset hub (e.g., as illustrated in FIGS. **4A** and **4B**) or terminate with trimmed ends **142** much like that shown in FIG. **8B** (with or without incorporated polymer) or be otherwise configured.

[0099] In any case, FIGS. **10A-10D** illustrates one approach to constructing a folded-section implant in which the profile of the fold is minimized. As will be appreciated by those with skill in the art, elements of the method may be applied to various of the implant configurations discussed herein.

[0100] In these figures, FIG. **10A** shows a section of braid **200**, tied with suture **202** upon a mandrel **204**. The tie is offset from where the braid is cut so that when the braid is inverted as shown in FIG. **10B**, the outer layer **28** extends past the inner layer **26**. A loose fold **210** is developed and the braid surrounds the implant shaping form **212**.

[0101] In FIG. **10C**, the braid is stretched and secured by wrap **214** (typically Pt or Stainless Steel wire) around the ball form **212**. Compression forms **216**, **218** are also shown (held by fixturing as indicated by arrows). Fold-side form **216** compresses the fold to a minimum profile during heat setting (e.g., for Nitinol braid at 550° C. for 5 minutes). In this

process, the original tie **202** (if made of suture) burns away removing any impediment for achieving a zero or near-zero radius bend at the fold. Opposite form **218** may define a sharp shoulder section (for when that end of the ball is to be trimmed and used as the distal end, in a “floating-layer” ball as described below, etc.) or shape a recapture profile into the braid.

[0102] After any such shape-setting, a device perform **220** is ready once the internal form is finally removed as illustrated in FIG. **10D**. During this process, the ends of the braid are forced open and typically lose braid integrity/engagement. So that such action does not adversely affect the implant integrity, a “tail” **220** incorporated in the perform **220** should be sufficiently long (i.e., often about 2 cm or more) so as to avoid any damage from unraveled braid ends impacting the intended body **224** of the implant.

[0103] If the implant is formed from braid that includes an oxide layer, the perform is next etched, then passivated. However, if pre-etched wire is employed in braiding and any heatsetting performed in a salt pot, vacuum furnace, or using other equipment to minimize oxide formation, the perform may simply be subject to Nitric acid passivation.

[0104] Even in additional intermediate process steps are employed, FIG. **10E** illustrates a manner in which a band **50** may be added in forming a hub. Specifically, after tying the outer layer **28** with a wrap **226**, the band may be threaded over this section. Without the inner layer underneath, the tied section **228** fits within the band **50** such that the band can be sized to tightly fit around both layers of braid (and an optional mandril **230**—the utility of which is discussed below) when advanced to a point adjacent the implant body **224**.

[0105] As an alternative approach to compression-forming the fold during perform shaping to achieve a minimum radius bends in the braid wire is presented in FIGS. **11A** and **11B**. These figures illustrate a technique for presetting the shape of the implant fold. In FIG. **11A**, wedges **240** of a crimper device (e.g., as available through Machine Solutions, Inc. and others) receive braid **200** that is folded over to define a plurality of bends. A mandrel **242** is advantageously set inside the braid. The mandrel limits compression of the braid tube, requiring the bends radius tighten when the aperture **244** formed by the wedges is closed as indicated in FIG. **11B**. The shape of the fold is set by heat and/or a combination of strain and heat. The heat may be applied by a torch, within a furnace or, advantageously, by running current through the mandrel. In another approach, a multi-element chuck or collet type device is employed in a similar fashion to the crimper wedges illustrated above.

[0106] So-shaped, the overall implant may be formed largely as described in connection with FIGS. **10A-10D** without the use of the suture tie or compression for **216**. Instead, a permanent fine-wire tie that remains throughout the process may be employed to close the folded end of the ball. This tie can be installed simply by flipping back the folded braid to expose the bends. Alternatively, it can be treaded through and around the bend folds with a needle and tied.

[0107] Pre-treating the fold or compression forming it during heatsetting the bulk of the implant is advantageous especially for those cases in which the region adjacent the fold is to be dome shaped. However, when a nubbin is acceptable in the device design given its intended use (e.g., PVO) FIGS. **12A** and **12B** illustrate another approach. Specifically, a hypotube **250** (or other shaped form including a pocket) is placed over the braid where the braid is trapped between a

band **50** and/or the band and mandrel **204** as shown. In addition, as shown in FIG. **12B**, a second hypotube **252** (or surface in a form pocket) can abut the distal bend point **254** to further constrain the braid for precision shape setting.

[0108] As for setting the remaining shape of the implant or its perform **220**, FIG. **12A** illustrates the use of a proximal trumpet shaped form **256** to set a smooth recapture profile. In FIG. **12B**, the proximal form **258** sets tight or sharp radius. Such a shape may be desired to achieve higher radial force in the implant due to greater local bending strain.

[0109] The implant shown in FIG. **12B** seeks to achieve improved anchoring over that in FIG. **12A** by virtue of the other noteworthy feather illustrated in the drawings. Namely, the cylindrical band **260** shape set in the implant along the otherwise ovular device shape produces edges **262** that interact with vascular tissue with increased local stress to improve anchoring.

[0110] Both implants still share a flattened/reduced aspect ratio relative the spherical ball implants previously pictured. Such an aspect ratio allows for greater oversize for anchoring the self-expanding implants in vessel for a resulting length of device. This fact is advantageous given that the focal length of occlusion is often important in treating neurovascular defects in order to inadvertently block adjacent perforator/branch vessels in PVO applications.

[0111] Whatever the form of the implant, when a hub is included to secure the braid filaments, certain affixation challenges must be addressed. The hub must be securely fastened to the braid and it may be necessary to minimize the length of the feature. FIGS. **13A** and **13B** are partial side-sectional views illustrating alternate braid/band affixation approaches. In FIG. **13A**, band **50** is set past a trim line for the braid. The small resulting tail **270** provides a surface across which glue **272** can be applied. Once cured (e.g., by UV application) the adhesive is entrained in the braid and forms an edge **274** over which the band cannot pass. If glue is not used, then the braid may be melted with a laser to similarly form an interference feature for the band. Such laser application may weld the braid to an internal band **276** if one is employed. The laser may be applied in a radial direction around the braid, or axially across the trimmed face of the braid.

[0112] Especially when utilizing laser energy, an alternative approach as illustrated in FIG. **13B** may be employed. Here, by applying laser energy directed axially across the edge of the band(s) and the face of the braid, all of these may be welded together. Even if so-welded, the resulting face may be sealed with polymer adhesive **272**.

[0113] FIG. **14** illustrates yet another approach to hub fixation. Here, wicking is relied upon for glue/adhesive penetration through the braid under the band to form a bond. A bead **280** of glue is applied to an exposed segment of braid **200** adjacent the band **50**. A non-stick (e.g., PTFE coated) mandrel **230** may be situated inside the braid to precisely define a lumen within the glue-impregnated braid. The lumen advantageously operates as a delivery system port. Once the adhesive is cured and the mandrel is removed, a precisely-sized composite wall structure is produced.

[0114] The adhesive may be applied evenly around the braid by rotating the assembly as indicated. Other approaches may be utilized as well. In one such approach a plurality of optional access windows **282** may be included in the band to receive and disperse adhesive. Adhesive is also optionally wicked away from the braid **200** by a paper card or absorptive fiber pad **284** (or removed by other means) so that any excess

of wicking/flowing adhesive utilized to ensure braid lumen coverage and/or band 50 adhesion does not interfere with the self-expanding action of the implant body 224.

[0115] Use of an inner band 276 is also optional. While it occupies space that the braid-and-glue only lumen conserves, including an inner band in the hub assembly 42 may sometimes be desirable for the detachment system interface.

[0116] Use of an adjunct hypotube 286 is also optional. This tube, however, offers a useful grip or handle on which to clamp for subsequent trimming. Especially for such use, a thick-walled (e.g., about 0.005" or greater) tube may be desirable because of additional stability it will yield. As with the band which becomes part of the implant, hypotube 286 may include one or more access windows 282 for adhesive application.

[0117] For trimming an implant perform 220 (however it is shaped), FIG. 15 illustrates an approach that coordinates well with the hub affixation approach illustrated in FIG. 14. Specifically adjunct hypotube is captured in a fixture 290 mounted on a slide 292. Lateral adjustment may be provided for in order to align a saw blade 294 (typically a 0.004-0.010 inch diamond-coated wheel) with a gap 296 established between the band and hypotube 286 grip. Once aligned (the cut line may be at the gap, or the band itself may be cut down) the implant is trimmed-off. To aid in handling, the implant may be at least partially constrained in a sheath 298 as shown. A precision cut/trim allows for a band (as trimmed or initially installed) as short as about 0.010 inch in height. A more conservative size (e.g., about 0.020 inch in height) may however be desired to ensure braid capture and detachment system robustness.

[0118] After the cut is made, the hub length may be further reduced by grinding its face. After mandrel removal (also cut-off in the trimming procedure) and cleaning in an ultrasonic bath, the hub face may be sealed with adhesive.

[0119] Produced using any of the referenced hubbing techniques, another implant variation 300 is illustrated in FIG. 16. Additional steps unique to its manufacture are presented in FIGS. 17A-17D.

[0120] The implant differs from those discussed above in that it includes a layer of braid that is not secured at each end of the device. Rather, the inner layer 26 "floats". Its presence augments implant density, but its fibers adjacent the hub 42 are not forced to bend when the ball is compressed in a sheath for delivery and/or recapture. As such, relatively less force is required for recapture, even when the braid is bent at approximately 90 degrees upon exiting the hub (i.e., without the proximal end of the implant body 224 including a recapture profile in the design).

[0121] To produce a ball with the inner braid ends 302 proximate to the hub where the density of the outer braid is highest and best able to prevent individual filaments from the inner layer poking through the braid matrix, an elegant set of manufacturing steps are carried out. Specifically, after starting with an implant perform 220 as shown in FIG. 17A, the outer layer of braid is pulled or pushed off of the intended body 224 of the implant as shown in FIG. 17B. The inner layer of braid is trimmed as shown in FIG. 17C. Wire cutters, scissors or other means may be employed. Finally, the outer layer is returned to its original position as shown in FIG. 17D and the implant perform is further processed.

[0122] Such further process may include banding/hubbing, trimming and/or tying the fold aperture closed. However,

such tying may advantageously be performed prior to restoring the position of the outer braid while the fold 24 is exposed per FIG. 17B/17C.

[0123] Whatever techniques are employed in their construction, the implants are advantageously mounted to a releasable pusher. Delivery system 310 in FIG. 18 includes a hypotube shaft 312 with cut-out windows 314. The window 312 adjacent the ball hub is critical, the other merely advantageous. A core member 316 (advantageously Nitinol ribbon) exits the proximal window 312 or cutout and re-enters at the second 314. A shoulder/bumper 316 attached to the hypotube abuts a proximal end of the hub 50 to push the implant 40. Alternatively, an external sleeve (not shown) running to the length of the hypotube to a delivery system strain relief 318 and/or hub 320 may be provided. To permit retracting the implant into the delivery catheter (not shown), core member 316 engages the inner surface of the hub lumen (hidden) to retain the implant.

[0124] To allow release, the core member is withdrawn into hypotube 310 clearing each of the windows 312, 314 by pulling finger grip 322. At which point, the hypotube may exit the hub port 54 by withdrawing the pusher.

[0125] Another detachable delivery system 330 is illustrated in FIGS. 19A and 19B. It is a fully co-axial design in which control wires 332 are pulled to release interference of a head 334 mounted on an anchor wire 336 otherwise unable to pass through a hub port or lumen 54. Because the wires are pulled straight out and only position the anchor wire head to ensure interference (clearly illustrated in FIG. 19B) minimal effort is required. EPTFE coating over at least the control wires is also useful.

[0126] The control wires 332 may extend to or past the anchor wire head 334 (the former case illustrated in FIG. 19A). Another option is to limit the control wire length to that of any inner band 276 or overall hub 42 height dimension (as illustrated in FIG. 19B). Note also: FIG. 19A shows a gap between a pusher sleeve 338 and implant hub 50. This representation is for illustration purposes only.

[0127] In any case, each of the pusher sleeve lumen 340 and the implant hub lumen/port 52 are preferably sized so that the wires (control wires 332 and anchor wire 336) are received in a close-packed arrangement. In this manner, the implant and pusher sleeve serve as a guide eliminating loading difficulties associated with the wires becoming braided or entwined. Also for loading the system, the anchor wire is typically tensioned to a very slight degree (prior to simple gluing into a handle or using a bias spring incorporated in the handle design) to ensure any gap between the implant and pusher is closed and remains closed in use.

[0128] FIGS. 20A-20F illustrate a variation of delivery system 330 is use. The distal end of the detachment system is shown with the hub 42 portion of an implant. FIG. 20A shows the pusher interlock engaged. FIGS. 20B-20D illustrate sequential withdrawal of the control wires 332. Anchor wire 336 may also be individually withdrawn as shown in FIG. 20E. However, it may instead be withdrawn with the detachment system sleeve 338. Indeed, it may be affixed to the sleeve. Still further, it is to be recognized that the control wires need not be pulled one at a time. They can be actuated together. In any case, complete implant separation is illustrated in FIG. 20F.

[0129] Finally, FIG. 21 presents an overview of a treatment system 340 including an implant 342 and handle 342. Either one or both of these may be constructed according to the

teachings herein. The handle **342** shown includes three knobs. Two knobs **344** are connected to control wires (hidden from view), and the last knob **346** to an anchor wire (hidden from view). A removable locking cap **348** may be included in the handle design as well as a strain relief section **350**. The catheter/pusher shaft **338** may comprise a simple extrusion (e.g., PTFE, FEP, PEEK, etc.) or may be constructed using conventional catheter construction techniques and include a liner, braid support and outer jacket (not shown). A loading sheath **352** is typically provided over the pusher shaft. Advantageously, the loading sheath is splittable as is model shown.

[0130] After removal from sterile packaging (not shown), the implant is pulled into the loading sheath **350**. The loading sheath is received within the hub of the catheter to be used for implant delivery and the implant is advanced into the catheter. Then, the implant may be advanced to and deployed at a treatment site. Or it may be retrieved in exchange for another size implant, else repositioned if desired prior to ultimate detachment like that illustrated in FIGS. **20A-20F**.

[0131] The subject methods may include each of the physician activities associated with implant positioning and release. As such, methodology implicit to the positioning and deployment of an implant device forms part of the invention. Such methodology may include placing an implant within a brain aneurysm, or at parent vessel targeted for occlusion, or other applications. In some methods, the various acts of implant introduction to an aneurysm or parent vessel are considered.

[0132] More particularly, a number of methods according to the present invention involve the manner in which the delivery system operates in reaching a treatment site, for example. Other methods concern the manner in which the system is prepared for delivering an implant, for example attaching the braid ball to the delivery system. Any method herein may be carried out in any order of the recited events which is logically possible, as well as in the recited order of events, or slight modifications of those events or the event order.

[0133] Also, it is contemplated that any optional feature of the inventive variations described may be set forth and claimed independently, or in combination with any one or more of the features described herein. Reference to a singular item, includes the possibility that there is a plurality of the same items present. More specifically, as used herein and in the appended claims, the singular forms “a,” “an,” “said,” and “the” include plural referents unless specifically stated otherwise. In other words, use of the articles allow for “at least one” of the subject item in the description above as well as the claims below. It is further noted that the claims may be drafted to exclude any optional element. As such, this statement is intended to serve as antecedent basis for use of such exclusive terminology as “solely,” “only” and the like in connection with the recitation of claim elements, or use of a “negative” limitation.

[0134] Without the use of such exclusive terminology, the term “comprising” in the claims shall allow for the inclusion of any additional element irrespective of whether a given number of elements are enumerated in the claim, or the addition of a feature could be regarded as transforming the nature of an element set forth in the claims. Except as specifically defined herein, all technical and scientific terms used herein are to be given as broad a commonly understood meaning as possible while maintaining claim validity.

[0135] The breadth of the present invention is not to be limited to the examples provided and/or the subject specification, but rather only by the scope of the claim language. Use of the term “invention” herein is not intended to limit the scope of the claims in any manner. Rather it should be recognized that the “invention” includes the many variations explicitly or implicitly described herein, including those variations that would be obvious to one of ordinary skill in the art upon reading the present specification. Further, it is not intended that any section of this specification (e.g., summary, detailed description, abstract, field of the invention) be accorded special significance in describing the invention relative to another or the claims. All references cited are incorporated by reference in their entirety. Although the foregoing invention has been described in detail for purposes of clarity of understanding, it is contemplated that certain modifications may be practiced within the scope of the appended claims.

What is claimed:

1. A device for implantation within a vascular defect or aneurysm, comprising:

a self-expanding resilient outer layer having a proximal end, a distal end, a longitudinal axis and further comprising:

a plurality of elongate resilient filaments disposed in a woven structure, the filaments being secured relative to each other at proximal ends and distal ends thereof,

a radially constrained elongated state configured for delivery within a microcatheter with the thin woven filaments extending longitudinally from the proximal end to the distal end radially adjacent each other along a length of the filaments, and

an expanded relaxed state with a globular and longitudinally shortened configuration relative to the radially constrained state with the woven filaments forming the self-expanding resilient permeable shell in a smooth path radially expanded from the longitudinal axis between the proximal end and distal end including a plurality of openings in the shell formed between the woven filaments, the largest of said openings being configured to reduce blood flow velocity through the openings to a velocity below a threshold velocity; and

an inner layer of filamentary members disposed within the resilient permeable shell.

2. The device of claim **1** wherein the largest of the openings in the shell formed between the woven filaments are configured to reduce blood flow velocity through the openings to a velocity below a thrombotic threshold velocity.

3. The device of claim **1** wherein the largest of the openings in the shell formed between the woven filaments are configured to reduce blood flow velocity through the openings to a velocity that achieves hemostasis in the vascular defect or aneurysm.

4. The device of claim **1** wherein filaments of the resilient outer layer comprise a transverse dimension or diameter that is about 0.001 inches to about 0.004 inches.

5. The device of claim **1** wherein filaments of the inner layer comprise a transverse dimension or diameter that is less than about 0.001 inches.

6. The device of claim **1** wherein the resilient outer layer comprises about 70 to about 300 filaments extending from the first end to the second end.

7. The device of claim 1 wherein the inner layer comprises about 70 to about 300 filaments extending from a first end to the second end.

8. The device of claim 1 wherein a major transverse dimension of the resilient outer layer in a relaxed expanded state is about 4 mm to about 30 mm.

9. The device of claim 1 wherein the filaments of the inner layer or outer layer comprise a woven structure forming an enclosed volume.

10. The device of claim 9 wherein the inner layer comprises:

a radially constrained elongated state configured for delivery within a microcatheter with the thin woven filaments of the inner layer extending longitudinally from a proximal end to a distal end radially adjacent each other along a length of the filaments, and

an expanded relaxed state with a globular and longitudinally shortened configuration relative to the radially constrained state with the woven filaments forming a self-expanding resilient permeable shell in a smooth path radially expanded from the longitudinal axis between the proximal end and distal end including a plurality of openings in the shell formed between the woven filaments.

11. The device of claim 9 wherein a proximal end of the inner layer is secured to a proximal end of the resilient outer layer.

12. The device of claim 1 wherein the filaments of the outer layer comprise a first set of filaments, each filament of the first set having a first transverse dimension and a second set of filaments, each filament of the second set having a second transverse dimension different from the first transverse dimension.

13. The device of claim 1 wherein the filaments of the inner layer comprise a first set of filaments, each filament of the first set having a first transverse dimension and a second set of filaments, each filament of the second set having a second transverse dimension different from the first transverse dimension.

14. A device for implantation within a vascular defect or aneurysm, comprising:

a self-expanding resilient outer layer having a proximal end, a distal end, a longitudinal axis and further comprising

a plurality of elongate resilient filaments with a woven structure secured relative to each other at proximal ends and distal ends thereof,

a radially constrained elongated state configured for delivery within a microcatheter with the thin woven filaments extending longitudinally from the proximal end to the distal end radially adjacent each other along a length of the filaments, and

an expanded relaxed state with a globular and longitudinally shortened configuration relative to the radially constrained state with a major transverse diameter, the woven filaments forming the self-expanding resilient permeable shell in a smooth path radially expanded from the longitudinal axis between the proximal end and distal end, and including a plurality of openings in the shell formed between the woven filaments; and

wherein the diameter of the outer layer in an expanded state, number of all filaments and diameter of the small filaments are configured such that the average opening size of the permeable shell in an expanded state is less

than about 0.016 inches with the average opening size defined by the expression $(1.7/N_T)(\pi D - N_T/2 \times d_w)$ where D is a diameter of the permeable shell in the expanded state in inches, N_T is the total number of filaments in the permeable shell, and d_w is the diameter of the smallest filaments in inches; and

an inner layer of filamentary members disposed within the resilient outer layer.

15. The device of claim 14 wherein the filaments of the inner layer comprise a woven structure forming an enclosed volume.

16. The device of claim 14 wherein the inner layer comprises: a radially constrained elongated state configured for delivery within a microcatheter with the thin woven filaments of the inner layer extending longitudinally from a proximal end to a distal end radially adjacent each other along a length of the filaments, and an expanded relaxed state with a globular and longitudinally shortened configuration relative to the radially constrained state with the woven filaments forming a self-expanding resilient permeable shell in a smooth path radially expanded from the longitudinal axis between the proximal end and distal end including a plurality of openings in the shell formed between the woven filaments.

17. The device of claim 15 wherein a proximal end of the inner layer is secured to a proximal end of the outer layer.

18. The device of claim 14 wherein the filaments of the outer layer comprise a first set of filaments, each filament of the first set having a first transverse dimension and a second set of filaments, each filament of the second set having a second transverse dimension different from the first transverse dimension.

19. A device for implantation within a vascular defect or an aneurysm, comprising:

a self-expanding resilient outer layer having a proximal end, a distal end, a longitudinal axis and further comprising

a plurality of elongate resilient filaments with a woven structure secured relative to each other at proximal ends and distal ends thereof,

a radially constrained elongated state configured for delivery within a microcatheter with the woven filaments extending longitudinally from the proximal end to the distal end radially adjacent each other along a length of the filaments, and

an expanded relaxed state with a globular and longitudinally shortened configuration relative to the radially constrained state with a major transverse diameter, the woven filaments forming the self-expanding resilient permeable shell in a smooth path radially expanded from the longitudinal axis between the proximal end and distal end, and including a plurality of openings in the shell formed between the woven filaments; and

wherein the diameter of the permeable shell in an expanded state, number and diameter of large filaments and number and diameter of small filaments are configured such that the permeable shell in a constrained state has an outer transverse diameter of less than about 0.04 inches defined by the expression $1.48 ((N_1 d_1^2 + N_S d_S^2))^{1/2}$ where N_1 is the number of largest filaments in the permeable shell, N_S is the number of smallest filaments in the permeable shell, d_1 is the diameter of the largest filaments in inches, and d_S is the diameter of the smallest filaments in inches; and

an inner layer of filamentary members disposed within the resilient outer layer.

20. The device of claim 19 wherein the filaments of the inner layer comprise a woven structure forming an enclosed volume.

21. The device of claim 19 wherein the inner layer comprises:

a radially constrained elongated state configured for delivery within a microcatheter with the thin woven filaments of the inner structure extending longitudinally from a proximal end to a distal end radially adjacent each other along a length of the filaments, and

an expanded relaxed state with a globular and longitudinally shortened configuration relative to the radially constrained state with the woven filaments forming a self-expanding resilient permeable shell in a smooth path radially expanded from the longitudinal axis between the proximal end and distal end including a plurality of openings in the shell formed between the woven filaments.

22. The device of claim 19 wherein a proximal end of the inner layer is secured to a proximal end of the outer layer.

23. The device of claim 19 wherein the filaments of the outer layer comprise a first set of filaments, each filament of the first set having a first transverse dimension and a second set of filaments, each filament of the second set having a second transverse dimension different from the first transverse dimension.

24. The device of claim 19 wherein the filaments of the inner layer comprise a first set of filaments, each filament of the first set having a first transverse dimension and a second set of filaments, each filament of the second set having a second transverse dimension different from the first transverse dimension.

25. A device for implantation within a vascular defect or aneurysm, comprising:

a self-expanding resilient outer layer having a proximal end, a distal end, a longitudinal axis and further comprising:

a plurality of elongate resilient filaments with a woven structure secured relative to each other at proximal ends and distal ends thereof,

a radially constrained elongated state configured for delivery within a microcatheter with the woven filaments extending longitudinally from the proximal end to the distal end radially adjacent each other along a length of the filaments, and

an expanded relaxed state with a globular and longitudinally shortened configuration relative to the radially

constrained state with a major transverse diameter, the woven filaments forming the self-expanding resilient permeable shell in a smooth path radially expanded from the longitudinal axis between the proximal end and distal end, and including a plurality of openings in the shell formed between the woven filaments;

wherein the diameter of the outer layer in an expanded state, number and diameter of large filaments and number and diameter of small filaments are configured such that the outer layer in an expanded state has a radial stiffness of about 0.014 lbf to about 0.284 lbf defined by the expression $(1.2 \times 10^6 \text{ lbf}/D^4)(N_l d_l^4 + N_s d_s^4)$ where D is a diameter of the outer layer in the expanded state in inches, N_l is the number of large filaments in the outer layer, N_s is the number of small filaments in the outer layer, d_l is the diameter of the largest filaments in inches, and d_s is the diameter of the smallest filaments in inches; and

an inner layer of filamentary members disposed within the resilient outer layer.

26. The device of claim 25 wherein the filaments of the inner layer comprise a woven structure forming an enclosed volume.

27. The device of claim 26 wherein the inner layer comprises:

a radially constrained elongated state configured for delivery within a microcatheter with the thin woven filaments of the inner structure extending longitudinally from a proximal end to a distal end radially adjacent each other along a length of the filaments, and

an expanded relaxed state with a globular and longitudinally shortened configuration relative to the radially constrained state with the woven filaments forming a self-expanding resilient permeable shell in a smooth path radially expanded from the longitudinal axis between the proximal end and distal end including a plurality of openings in the shell formed between the woven filaments.

28. The device of claim 26 wherein a proximal end of the inner layer is secured to a proximal end of the outer shell.

29. The device of claim 25 wherein the filaments of the outer layer comprise a first set of filaments, each filament of the first set having a first transverse dimension and a second set of filaments, each filament of the second set having a second transverse dimension different from the first transverse dimension.

* * * * *