

Oct. 4, 1949.

V. C. GRASSO ET AL
COLLAPSIBLE SHELF

2,483,899

Filed Oct. 31, 1947

2 Sheets-Sheet 1

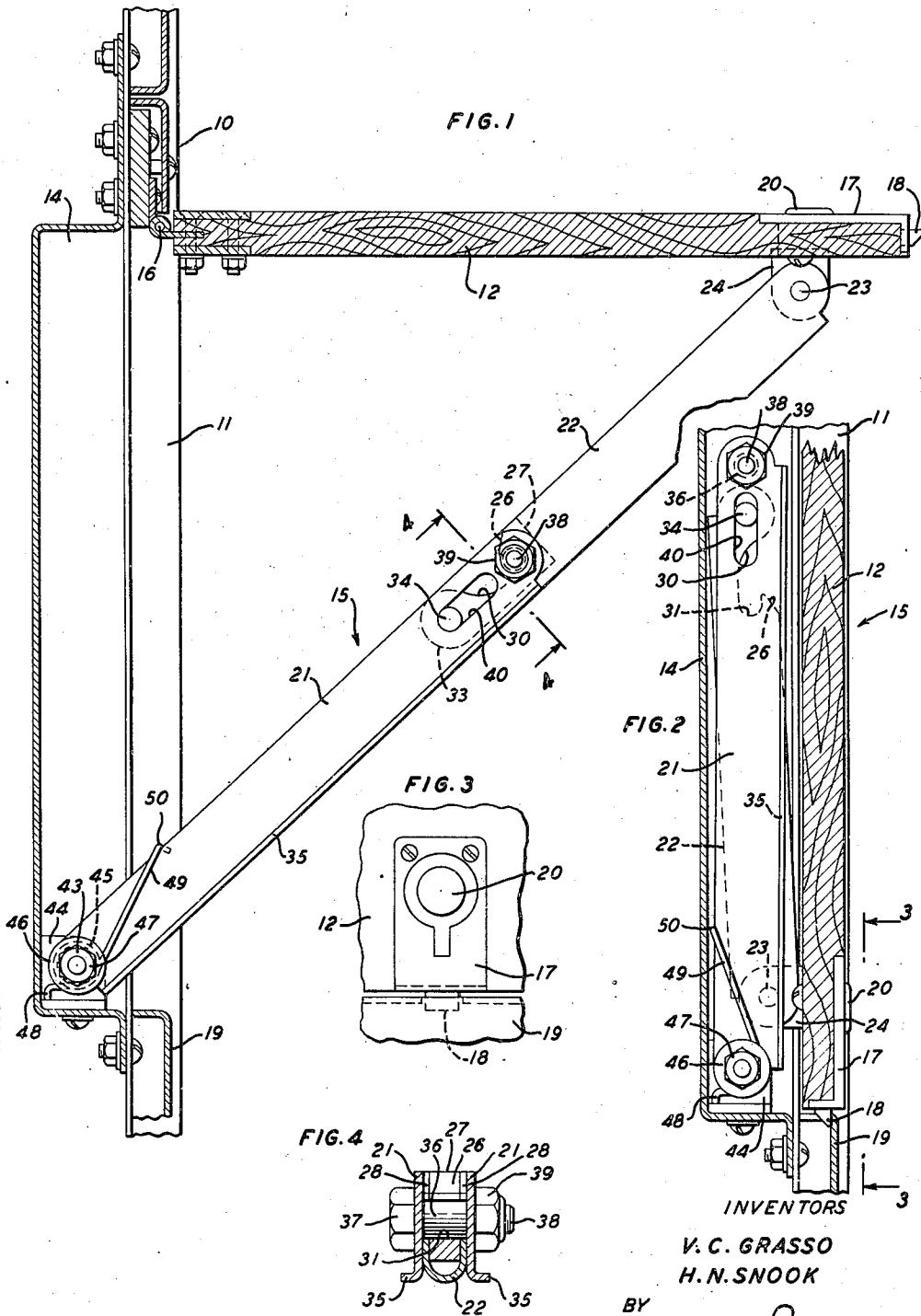

INVENTORS
V. C. GRASSO
H. N. SNOOK

BY *W. J. Farrell*
ATTORNEY

Oct. 4, 1949.

V. C. GRASSO ET AL

2,483,899

COLLAPSIBLE SHELF

Filed Oct. 31, 1947

2 Sheets-Sheet 2

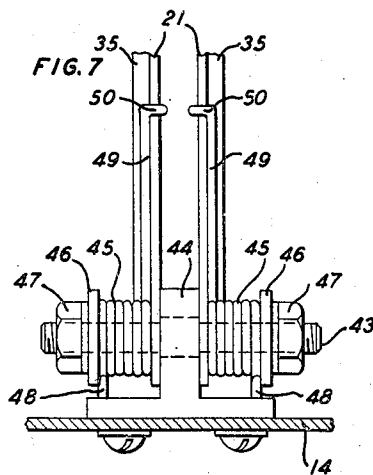
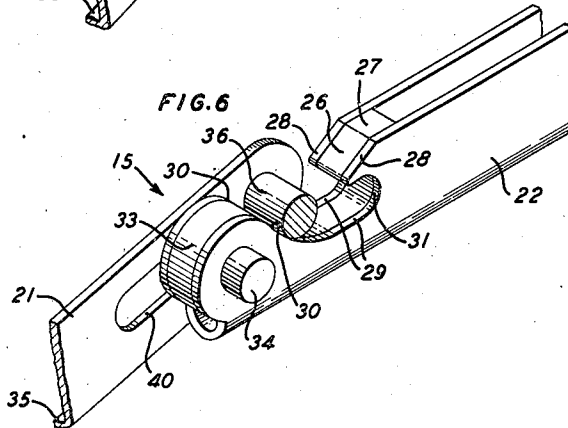
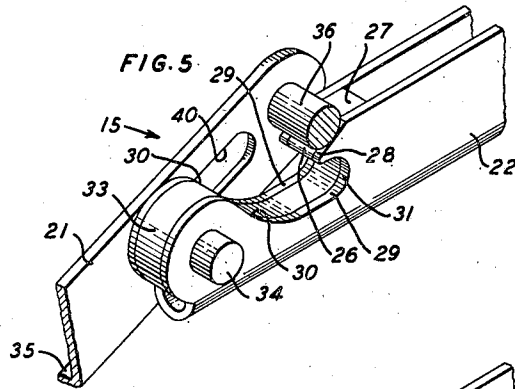

INVENTORS

V. C. GRASSO
H. N. SNOOK

BY

ATTORNEY

UNITED STATES PATENT OFFICE

2,483,899

COLLAPSIBLE SHELF

Vito Carmen Grasso, Bloomfield, and Harry Nelson Snook, Maywood, N. J., assignors to Western Electric Company, Incorporated, New York, N. Y., a corporation of New York

Application October 31, 1947, Serial No. 783,322

5 Claims. (Cl. 211-93)

1

This invention relates to collapsible shelves, and more particularly to a shelf which may be latched in a collapsed position and which will automatically open to a supporting position when unlatched.

Collapsible shelves have been found desirable in many fields, the present need for them being in crowded areas in a factory or laboratory where permanent shelves are undesirable. A particular need for shelves of this type has been found to exist in areas where heavy articles are carried into the area with no available place to put them. Furthermore, collapsible shelves of the commercially known types, which must be manually moved from their collapsed positions into supporting positions, are inadequate in such instances in that the person carrying a heavy article must first find a place to rest it while the shelf is manually opened to receive the article.

An object of the invention is to provide a collapsible shelf which may be normally latched in an out of the way position and which will automatically move into a rigid supporting position upon actuation of a latch.

With this and other objects in view, the invention comprises a frame to pivotally support a shelf having a collapsible arm pivoted at one end to the support and at the other end to the shelf with an intermediate expansible connection between the members of the arm to lock them in open position to form a rigid support for the shelf. A latch of the push button type, carried by the shelf for the support, may be actuated to release the shelf from its collapsed position to render a spring effective to force the arm from its collapsed position into its rigid open position, moving the shelf about its pivot into a supporting position. The intermediate structure of the arm includes a pivot pin carried by one of the arm members and movable in an elongate aperture of the other member, whereby a locking pin, carried by the apertured member, may ride over a cam of the pivot pin supporting member and into a retaining notch provided therefor to rigidly lock the members of the arm in aligned positions to form a rigid support for the shelf.

Other objects and advantages will be apparent from the following detailed description when considered in conjunction with the accompanying drawings wherein

Fig. 1 is a vertical sectional view of the collapsible shelf shown in open or supporting position;

Fig. 2 is a fragmentary vertical sectional view of the shelf in its collapsed position;

2

Fig. 3 is a fragmentary detailed view of the latch taken along the line 3-3 of Fig. 2;

Fig. 4 is an enlarged sectional view of one of the arms taken along the line 4-4 of Fig. 1;

5 Figs. 5 and 6 are enlarged fragmentary perspective views of the intermediate structure of one of the arms shown at different positions during the relative movements of the members thereof into open position; and

10 Fig. 7 is an enlarged fragmentary detailed view of the lower pivotal support for one of the arms and the springs for actuating the arm.

Referring now to the drawings, the support 10 for the collapsible shelf may be any desired structure including a wall, a bench, a desk, or the like. In the present embodiment of the invention, the support 10 is a vertical frame-like structure having an opening 11 to receive the shelf 12 and a housing 14 mounted on the support 10 and extending back of the opening 11 to house the arms, indicated generally at 15. The shelf 12 may be formed of wood or any suitable material, and be of any desired size or contour. The inner or upper edge of the shelf 12 is hinged or pivotally mounted 20 at 16 on the support 10 at the upper edge of the opening 11. A button type latch 17 is mounted adjacent the outer edge of the shelf 12 and positioned to have its plunger 18 engage an apertured member 19 mounted on the support 10 near the bottom of the opening 11. The latch 17 is of the commercially known type of push button latch, including a push button 20 which when pressed inwardly will move the plunger 18 inwardly to free it from the member 19 when the shelf is in the collapsed position shown in Fig. 2.

The desired number of the arms 15 that are employed depend upon the length of the shelf and the weight to be supported thereby. In the present embodiment of the invention two arms 15 are employed, only one arm being seen in Fig. 1 as the arms are mounted in general alignment with each other. The description of one arm will apply to both arms in the present embodiment or any desired number of arms to be employed. The arm 15 is composed of two main members 21 and 22, the member 22 being U-shaped in cross-section, as illustrated in Figs. 4, 5, and 6. The sides of the member 22, adjacent the upper end thereof (Fig. 1), are apertured to receive a pivot 23 supported by a bracket 24 mounted on the under surface of the shelf 12. The inner or lower end of the member 22 is of the contour shown in Figs. 5 and 6, including a cam surface 26 formed of a tapered surface of a filler block 27 and similar tapered surfaces 28 of the side walls

3

of the member 22. The filler block 27 is formed of suitable metal and is held in place by suitable means, such as welding. The cam surface 26 extends toward a cut-away portion 29 in the member 22, that is, the side walls thereof and the filler block 27, including a curved guiding surface 30 and a retaining notch 31. The adjacent end of the member 22 has its sides formed substantially circular to receive an annular portion 33 of the filler block 27 cooperating with the sides of the member 22 to support a pivot pin 34.

The member 21 of the arm 15 is composed of two separate portions parallel with the member 22 and positioned upon each side thereof. The lower edges 35 are bent at right angles to the main portions of the member 21 to add rigidity thereto. The inner ends of the portions of the member 21 are held at the desired spaced positions by a locking bolt 36, having a head 37 to engage one of the portions of the member 21 and a reduced threaded portion 38 extending through an aperture in the other portions of the member 21 and secured thereto by a nut 39.

Elongate apertures 40 are formed in the portions of the member 21 to receive the ends of the pivot pin 34 and in this manner provide a pivotal connection between the members 21 and 22 of the arm 15 which may be extended to allow telescoping of the members within given limits.

The detailed structure of the lower end of the member 21 of the arm 15 is shown in Fig. 7. A pivot or threaded shaft 43, supported at its center by a bracket 44, mounted in the housing 14, extends through apertures in the parallel portions of the member 21. Helical springs 45 have their main portions disposed concentric with the pivot 43 and held thereon by washers 46 and nuts 47. Short ends 48 of the springs 45, having right angle bends therein (Fig. 1), engage the base portion of the bracket 44 while the inner and longer ends 49 of the springs are hooked at 50 to extend around adjacent edges of the portions of the member 21.

It is necessary for manual actuation of the shelf to move it from its open or supporting position, shown in Fig. 1, to its closed or collapsed position, shown in Fig. 2. To accomplish this result, the shelf is raised or moved counterclockwise a distance allowed by the movement of the pivot pin 34 in the elongate apertures 40, during which movement the locking pin 36 is moved free of the notch or notches 31 and caused to climb the inclined or curved surface (Fig. 6), bending the arm portions 21 and 22 inwardly. By continuing movement of the central portion of the arm inwardly about the pivot pin 34, pivoting the outer portions of the members 21 and 22 about their pivots 43 and 23, the shelf may be lowered against the combined force of the springs 45 until it is latched in the collapsed position shown in Fig. 2.

When it is desirable to use the shelf to support an article, the button 20 of the latch 17 may be pressed to release the plunger 18, after which the shelf will be forced automatically into open position. The force for accomplishing this result is inherent in the springs 45, forcing the member 21 of the arm 15 outwardly and causing the member 22 to follow in moving the shelf 12 about its hinge 16.

As the members 21 and 22 of the arm 15 approach their aligned positions, shown in Fig. 1, the locking bolt 36 will first engage the cam

4

surface 26 (Figs. 5 and 6). The continued application of the force of the springs 45 will cause the locking bolt 36 to ride down the cam surface 26, and in so doing, move the member 22 longitudinally until the locking bolt has been moved beyond the cam surface 26 and into the cut-away portion 29. During this action of the arm, or arms, the shelf will have been moved slightly above this supporting position and will drop by gravity when the locking bolt 36 has passed beyond the cam surface 26 and entered the cut-away portion 29 to move the notch 31 down upon the bolt 36. The shelf is now locked in its open or supporting position and cannot be jarred to cause the arms 15 to collapse.

It has been found highly advantageous, over the commercially known collapsible shelves, to provide a shelf which may be collapsed into an out-of-the-way position when not desirable for use, and which may be instantaneously brought into its supporting position for use merely by pressing a button latch when it is desirable to use the shelf. All that is required of the person about to use the shelf is the application of pressure on button 20 of the latch 17. This may be accomplished in many obvious ways while the said person is holding an article which is to be disposed on the shelf with both hands. For example, the button may be pressed by the person's elbow, a thumb, or by a portion of the article he is holding.

It is to be understood that the above-described arrangements are simply illustrative of the application of the principles of the invention. Numerous other arrangements may be readily devised by those skilled in the art which will embody the principles of the invention and fall within the spirit and scope thereof.

What is claimed is:

1. A collapsible shelf comprising a support, a shelf hinged at one edge to the support, an arm having two members, the outer end of one member being pivotally connected to the shelf and the outer end of the other member being pivotally connected to the support, means pivotally connecting the inner ends of the arm members, a latch having cooperating members carried by the support and the shelf to hold the shelf in a collapsed position in the support, and a spring carried by the support and engaging the arm to actuate the arm to move the shelf into a supporting position when the latch is released.

2. A collapsible shelf comprising a support, a shelf hinged at one edge to the support, an arm having two members, the outer end of one member being pivotally connected to the shelf and the outer end of the other member being pivotally connected to the support, means pivotally connecting the inner ends of the arm members, a latch having cooperating members carried by the support and the shelf to hold the shelf in a collapsed position in the support, a spring carried by the support and engaging the arm to actuate the arm to move the shelf into a supporting position when the latch is released, and means to lock the arm members against accidental displacement when the shelf is in its supporting position.

3. A collapsible shelf comprising a support, a shelf hinged at one edge to the support, an arm having two members, the outer end of one member being pivotally connected to the shelf and the outer end of the other member being pivotally connected to the support, a pivot pin carried

5

by the inner end of one arm member and movably disposed in an elongate aperture in the inner end of the other arm member, a latch having cooperating members carried by the support and the shelf to hold the shelf in a collapsed position in the support, a spring carried by the support and engaging the arm to actuate the arm to move the shelf into a supporting position when the latch is released, and a locking element carried by the apertured arm member and receivable in a notch in the other arm member to lock the arm members against accidental displacement when the shelf is in the supporting position.

4. A collapsible shelf comprising a support, a shelf hinged at one edge to the support, an arm having two members, the outer end of one member being pivotally connected to the shelf and the outer end of the other member being pivotally connected to the support, a pivot pin carried by the inner end of one arm member and movably disposed in an elongate aperture in the inner end of the other arm member, a latch having cooperating members carried by the support and the shelf to hold the shelf in a collapsed position in the support, a spring carried by the support and engaging the arm to actuate the arm to move the shelf into a supporting position when the latch is released, a locking element carried by the apertured arm member and receivable in a notch in the other arm member to lock the arm members against accidental displacement when the shelf is in the supporting position, and a cam on the notched member to guide the locking element into the notch.

5

10

15

20

25

30

35

6

5. A collapsible shelf comprising a support having an opening therein, a shelf hinged at one edge adjacent the top of the opening, to the support, an arm having two members, the outer end of one member being pivotally connected to the shelf and the outer end of the other member being pivotally connected to the support, means pivotally connecting the inner ends of the arm members, a latch having cooperating members carried by the support and the shelf to hold the shelf in a collapsed position within the opening closing the opening from one side of the support, and a spring carried by the support and engaging the arm to actuate the arm to move the shelf into a supporting position when the latch is released.

VITO CARMEN GRASSO.
HARRY NELSON SNOOK.

REFERENCES CITED

The following references are of record in the file of this patent:

UNITED STATES PATENTS

Number	Name	Date
687,031	Jeffcott	Nov. 19, 1901
747,570	Pickop	Dec. 22, 1903
965,816	Hill	July 26, 1910
1,199,849	Willoughby	Oct. 3, 1916
1,498,319	Dexter	June 17, 1924
1,583,280	Cummings	May 4, 1926
2,047,401	Whitted	July 14, 1936
2,284,003	Luppert	May 26, 1942