



US00D697002S

(12) **United States Design Patent**
Tanevski

(10) **Patent No.:** **US D697,002 S**

(45) **Date of Patent:** **** Jan. 7, 2014**

(54) **WHEEL OR WHEEL COVER**

(75) Inventor: **Slavche Tanevski**, Stuttgart (DE)

(73) Assignee: **Daimler AG**, Stuttgart (DE)

(**) Term: **14 Years**

(21) Appl. No.: **29/371,292**

(22) Filed: **Dec. 21, 2010**

(30) **Foreign Application Priority Data**

Jun. 22, 2010 (EM) 001722547-0003

(51) **LOC (10) Cl.** **12-16**

(52) **U.S. Cl.**
USPC **D12/209**

(58) **Field of Classification Search**
USPC D12/204-213; 301/37.101, 64.101, 65,
301/64.201
See application file for complete search history.

(56) **References Cited**

U.S. PATENT DOCUMENTS

D608,710 S * 1/2010 Nissl D12/209
D616,800 S * 6/2010 Zhao D12/209

D641,678 S * 7/2011 Elmitt D12/209
D644,976 S * 9/2011 Nissl D12/209
D648,254 S * 11/2011 Barry D12/209
D651,956 S * 1/2012 Ectors et al. D12/209
D660,771 S * 5/2012 Mueller-Stolz D12/211
D663,669 S * 7/2012 Baum D12/209
D664,081 S * 7/2012 Muller D12/209
D671,057 S * 11/2012 Tanevski et al. D12/209

* cited by examiner

Primary Examiner — Stacia Cadmus

(74) *Attorney, Agent, or Firm* — Crowell & Moring LLP

(57) **CLAIM**

The ornamental design for a wheel or wheel cover, as shown and described.

DESCRIPTION

FIG. 1 is a front view of a wheel or wheel cover according to my design; and,
FIG. 2 is a perspective view thereof.
The broken line showing of the rear of the wheel and on the central hub area is included for the purpose of illustrating environment and forms no part of the claimed design.

1 Claim, 1 Drawing Sheet

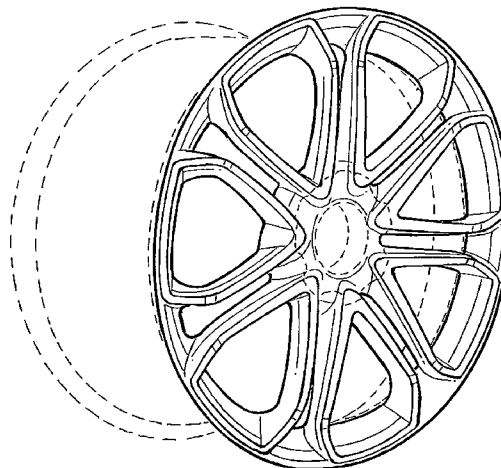
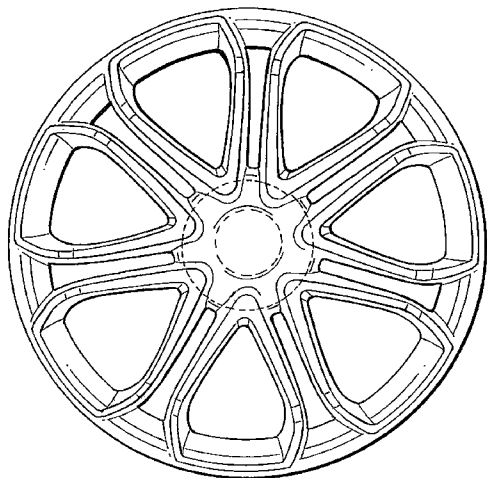

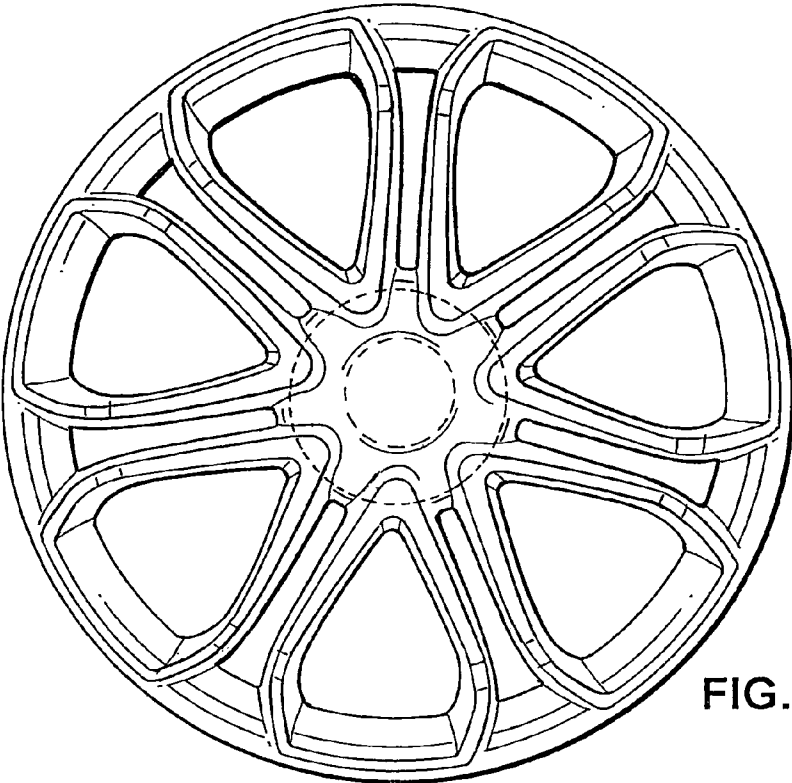

FIG. 1

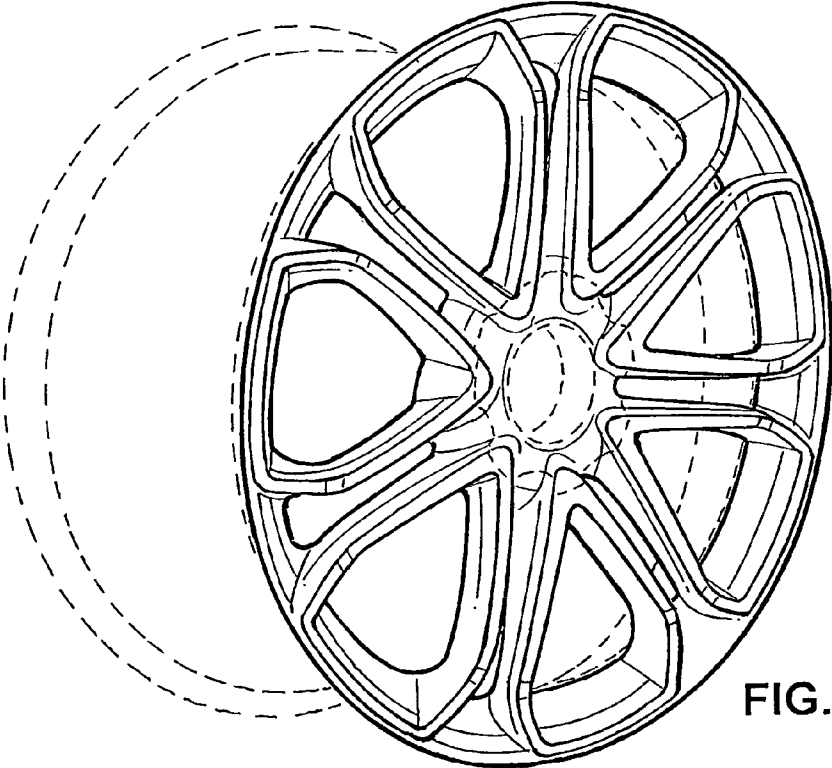

FIG. 2