



US0D1046691S

(12) **United States Design Patent**
Xiao

(10) **Patent No.:** **US D1,046,691 S**

(45) **Date of Patent:** **** Oct. 15, 2024**

- (54) **CARGO TRACTOR**
- (71) Applicant: **NextGen Exchange Group Inc.**, Grand Cayman (KY)
- (72) Inventor: **Fuwen Xiao**, Zhangzhou (CN)
- (73) Assignee: **Nextgen Exchange Group Inc.**, Grand Cayman (KY)

D945,931 S *	3/2022	Kim	D12/93
D977,389 S *	2/2023	Auerbach	D12/196
D977,391 S *	2/2023	Auerbach	D12/196
D978,041 S *	2/2023	Auerbach	D12/196
D981,284 S *	3/2023	Su	D12/93
D981,285 S *	3/2023	Su	D12/93
D990,373 S *	6/2023	Kim	D12/96
D1,008,098 S *	12/2023	Auerbach	D12/96

- (**) Term: **15 Years**
- (21) Appl. No.: **29/849,682**
- (22) Filed: **Aug. 12, 2022**

FOREIGN PATENT DOCUMENTS

CA	169260	*	6/2017
CA	214080	*	12/2023

* cited by examiner

Primary Examiner — Marissa J. Cash
Assistant Examiner — Garreth C. Blackwell
 (74) *Attorney, Agent, or Firm* — Dorsey & Whitney LLP

- (30) **Foreign Application Priority Data**
 Mar. 14, 2022 (CN) 202230128943.8
- (51) **LOC (14) Cl.** **12-08**
- (52) **U.S. Cl.**
 USPC **D12/93**
- (58) **Field of Classification Search**
 USPC D12/93, 96, 99, 173, 196
 CPC B62D 25/10; B62D 25/06; B62D 65/02;
 B62D 25/12; B60Q 1/00
 See application file for complete search history.

(57) **CLAIM**

The ornamental design for a cargo tractor, as shown and described.

DESCRIPTION

FIG. 1 is a left front isometric view of a cargo tractor, showing my ornamental design.
 FIG. 2 is a left rear isometric view of the cargo tractor.
 FIG. 3 is a front elevation view of the cargo tractor.
 FIG. 4 is a rear elevation view of the cargo tractor.
 FIG. 5 is a left side elevation view of the cargo tractor.
 FIG. 6 is a right side elevation view of the cargo tractor; and,
 FIG. 7 is a top plan view of the cargo tractor.
 The broken lines in the drawings depict portions of the cargo tractor that form no part of the claimed design.

- (56) **References Cited**
U.S. PATENT DOCUMENTS
 D425,826 S * 5/2000 Hellhake D12/96
 D650,722 S * 12/2011 Marchi D12/96
 D814,357 S * 4/2018 Milton D12/93
 D825,391 S * 8/2018 Von Holzhausen D12/96
 D825,392 S * 8/2018 Von Holzhausen D12/96
 D859,217 S * 9/2019 Von Holzhausen D12/96
 D860,056 S * 9/2019 Von Holzhausen D12/96

1 Claim, 7 Drawing Sheets

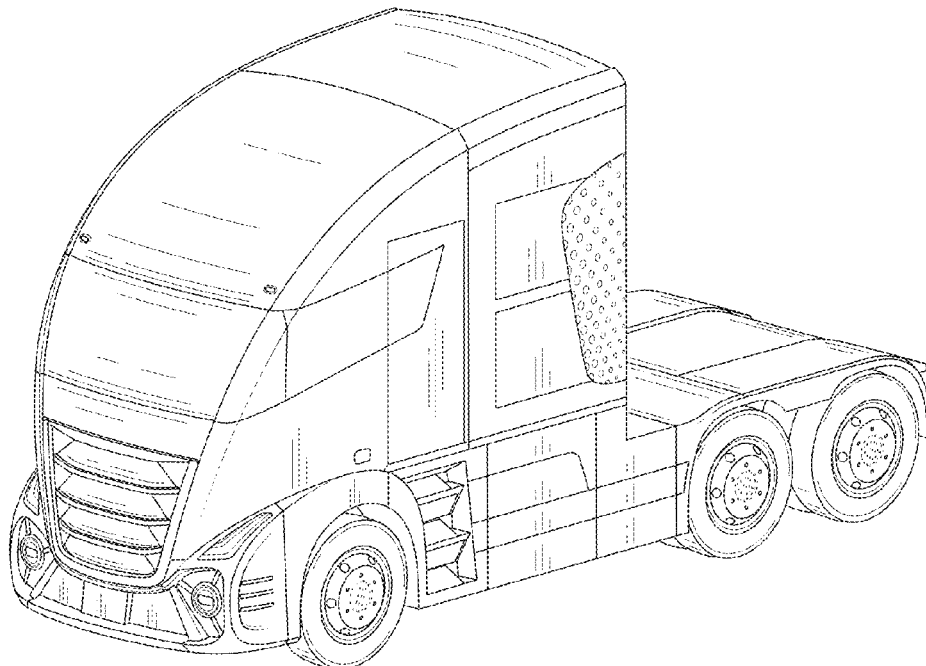

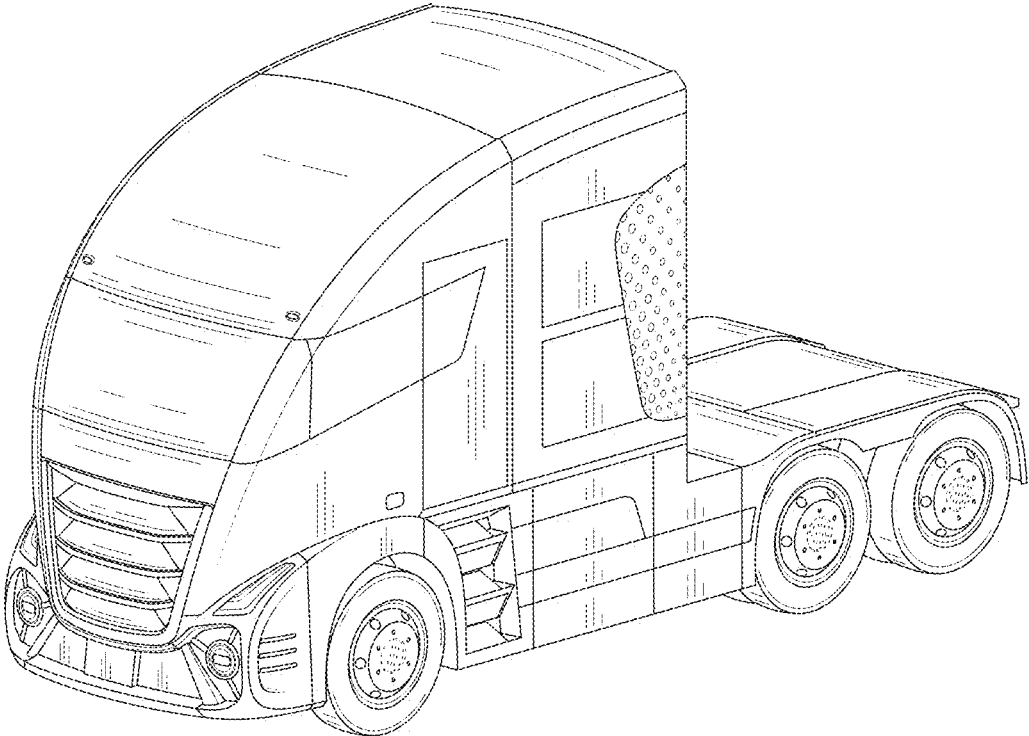

FIG. 1

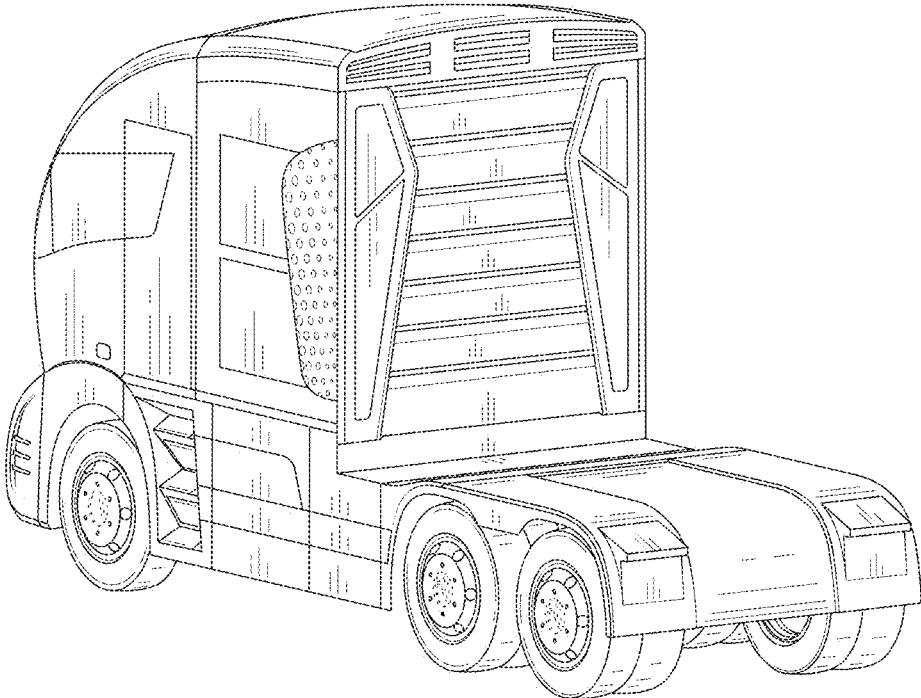

FIG. 2

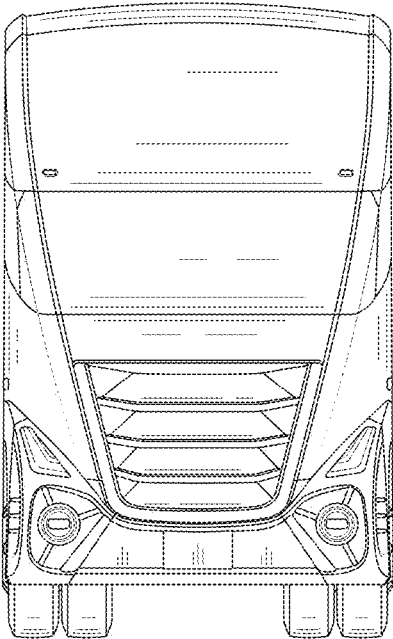

FIG. 3

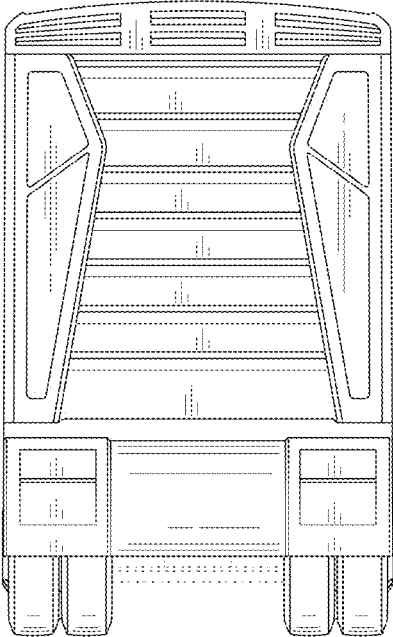

FIG. 4

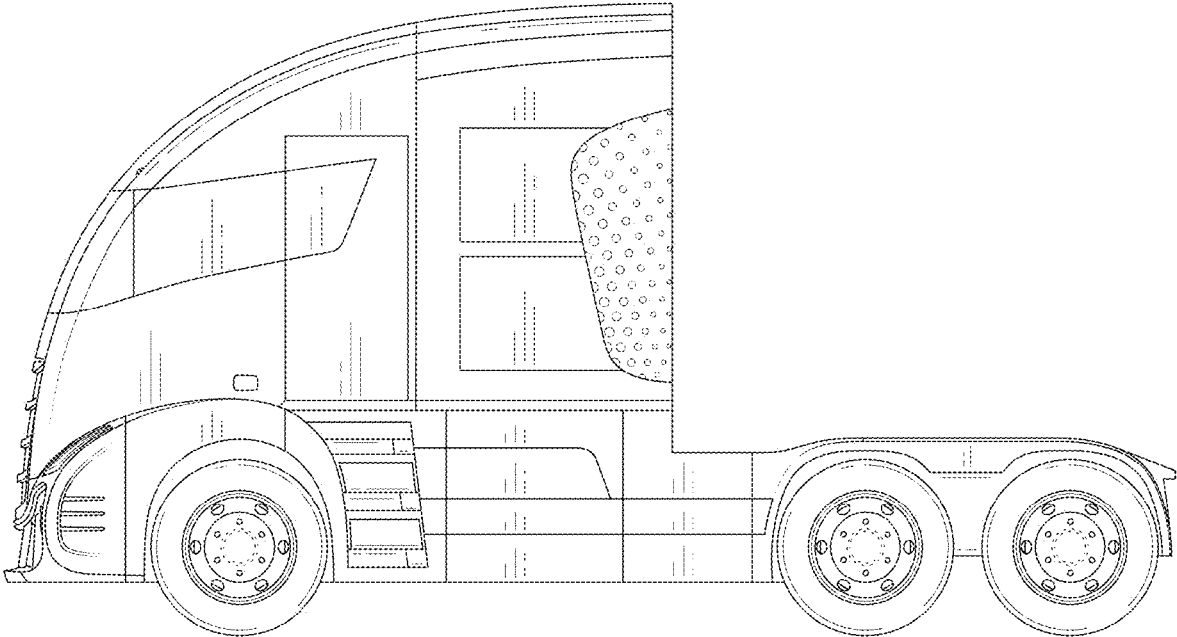

FIG. 5

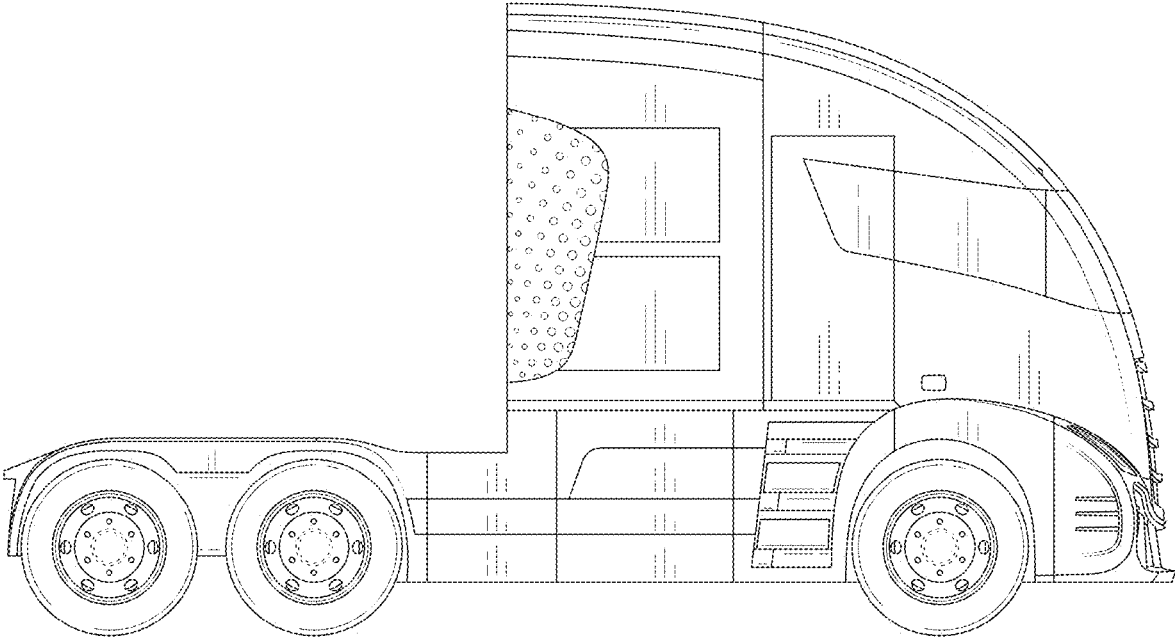

FIG. 6

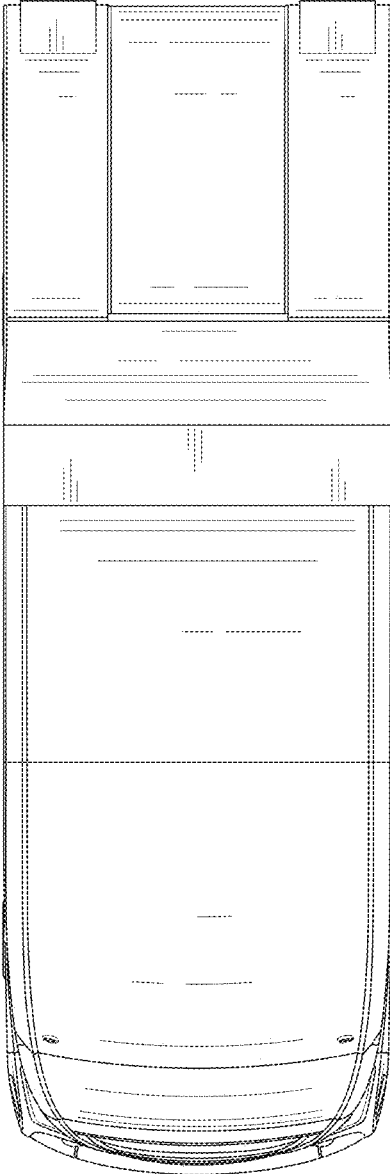

FIG. 7