

(19) World Intellectual Property Organization
International Bureau



(43) International Publication Date
20 April 2006 (20.04.2006)

PCT

(10) International Publication Number
WO 2006/042316 A1

(51) International Patent Classification:

C23G 5/032 (2006.01) CI1D 1/72 (2006.01)
CI1D 3/20 (2006.01) CI1D 1/66 (2006.01)
CI1D 3/43 (2006.01) CI1D 11/00 (2006.01)
CI1D 7/50 (2006.01)

(21) International Application Number:

PCT/US2005/036908

(22) International Filing Date: 12 October 2005 (12.10.2005)

(25) Filing Language: English

(26) Publication Language: English

(30) Priority Data:

60/617,930 12 October 2004 (12.10.2004) US

(71) Applicant (for all designated States except US): PAN-

THEON CHEMICAL, INC [US/US]; 22601 N. 19th Avenue, Suite 121, Phoenix, Arizona 85027 (US).

(72) Inventor; and

(75) Inventor/Applicant (for US only): ZAKI, Nael, Naguib [EG/US]; 10527 W. Patrick Lane, Peoria, Arizona 85383 (US).

(74) Agent: PILLOTE, Cynthia, L.; Snell & Wilmer LLP, One Arizona Center, 400 East Van Buren, Pheonix, Arizona 85004-2202 (US).

(81) Designated States (unless otherwise indicated, for every kind of national protection available): AE, AG, AL, AM, AT, AU, AZ, BA, BB, BG, BR, BW, BY, BZ, CA, CH, CN, CO, CR, CU, CZ, DE, DK, DM, DZ, EC, EE, EG, ES, FI, GB, GD, GE, GH, GM, HR, HU, ID, IL, IN, IS, JP, KE, KG, KM, KP, KR, KZ, LC, LK, LR, LS, LT, LU, LV, LY, MA, MD, MG, MK, MN, MW, MX, MZ, NA, NG, NI, NO, NZ, OM, PG, PH, PL, PT, RO, RU, SC, SD, SE, SG, SK, SL, SM, SY, TJ, TM, TN, TR, TT, TZ, UA, UG, US, UZ, VC, VN, YU, ZA, ZM, ZW.

(84) Designated States (unless otherwise indicated, for every kind of regional protection available): ARIPO (BW, GH, GM, KE, LS, MW, MZ, NA, SD, SL, SZ, TZ, UG, ZM, ZW), Eurasian (AM, AZ, BY, KG, KZ, MD, RU, TJ, TM), European (AT, BE, BG, CH, CY, CZ, DE, DK, EE, ES, FI, FR, GB, GR, HU, IE, IS, IT, LT, LU, LV, MC, NL, PL, PT, RO, SE, SI, SK, TR), OAPI (BF, BJ, CF, CG, CI, CM, GA, GN, GQ, GW, ML, MR, NE, SN, TD, TG).

Declarations under Rule 4.17:

— as to applicant's entitlement to apply for and be granted a patent (Rule 4.17(ii))

[Continued on next page]

(54) Title: COMPOSITION FOR CLEANING AND DEGREASING, SYSTEM FOR USING THE COMPOSITION, AND METHODS OF FORMING AND USING THE COMPOSITION

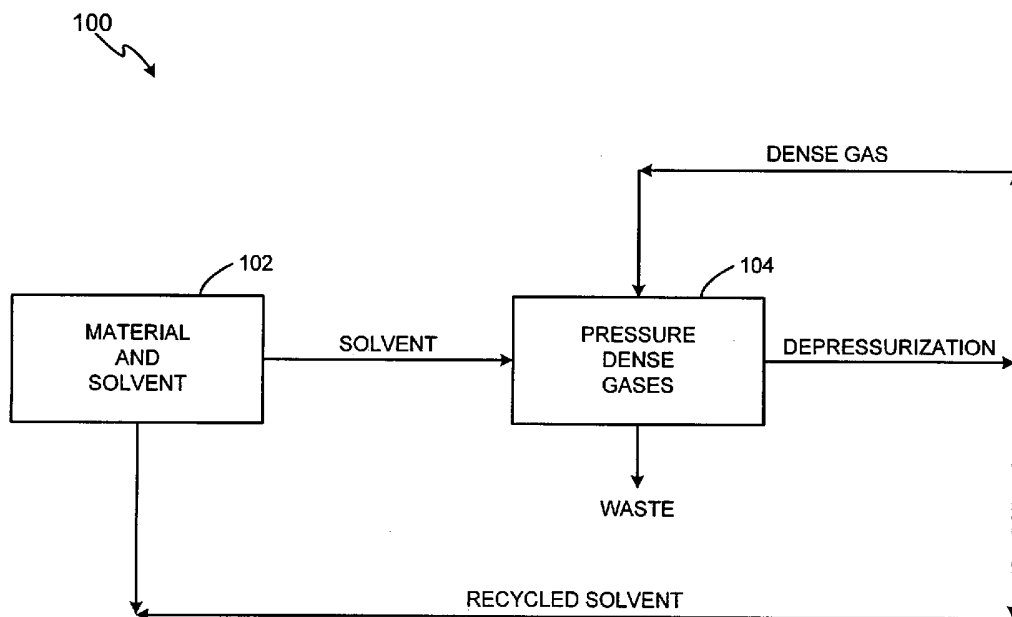

(57) Abstract: A composition for cleaning and degreasing substrates, methods of forming and using the composition, and a system and method for recycling the composition are provided. The composition includes a 2-ethylhexyl ester and may also include co-solvents, diluents, surfactants, and adjuvants.

WO 2006/042316 A1



— *as to the applicant's entitlement to claim the priority of the earlier application (Rule 4.17(iii))*

Published:

— *with international search report*

For two-letter codes and other abbreviations, refer to the "Guidance Notes on Codes and Abbreviations" appearing at the beginning of each regular issue of the PCT Gazette.

**COMPOSITION FOR CLEANING AND DEGREASING, SYSTEM FOR USING
THE COMPOSITION, AND METHODS OF FORMING AND USING THE
COMPOSITION**

Technical Field

The present invention relates, generally, to compositions for cleaning and degreasing substrates, and more particularly to environmentally benign cleaning compositions, including a 2-ethylehexyl ester component, to methods of forming and using the compositions, and to systems and methods of recycling the compositions.

Background of The Invention

Solvents such as diesel fuel have long been used to clean and degrease substrates. For example, diesel fuel is often used to remove products such as crude oil and asphalt from substrates such as equipment used for the manufacture and processing of asphalt materials. Although diesel fuel works relatively well at removing the oil-based products, diesel fuel is not considered environmentally benign and its use as an asphalt cleaner is banned in some countries.

Alternative, relatively environmentally benign solvents, such as d-limonene, have been developed to replace diesel fuel as a solvent. Unfortunately, several of these alternative solvents are generally not as efficient as diesel fuel at cleaning and degreasing, they often include volatile organic compounds, and/or they have an intolerable smell. In addition, several alternative solvent compounds have relatively low flash points, making them generally unsafe to handle. Accordingly, improved compounds and methods for cleaning and degreasing are desired.

In addition, the demand for cleaning and degreasing compounds in various cleaning and manufacturing processes is substantial and generally increasing. Thus, there is also a demand for methods and systems for recycling cleaning and degreasing compositions, to thereby reduce solvent consumption.

Summary of the Invention

The present invention provides a composition for cleaning and degreasing substrates, methods of forming and using the composition, and a method and system for recycling the composition. While the ways in which the present invention addresses the drawbacks of

known cleaning and degreasing solutions will be described in more detail below, in general, the present invention provides an environmentally benign composition that is efficient at cleaning and degreasing.

In accordance with various embodiments of the invention, a composition for cleaning and degreasing substrates includes a 2-ethylhexyl ester. Exemplary ester moieties include benzoate, cinnamate, salicylate, and other like esters.

In accordance with one embodiment of the invention, a composition includes from about 1 to about 100 weight percent 2-ethylhexyl ester, preferably about 20 to about 99.5 weight percent, and more preferably about 30 to about 99 weight percent 2-ethylhexyl ester (e.g., 70 to about 99.5 weight percent). In accordance with various aspects of this embodiment, the composition includes a co-solvent. In this case, the co-solvent is present in an amount of about 0 to about 99 weight percent, preferably about 0 to about 40 weight percent, and more preferably about 0.5 to about 20 weight percent.

In accordance with additional embodiments of the invention, a composition includes a 2-ethylhexyl ester component and a surfactant. The surfactant can be nonionic, for example a nonionic surfactant belonging to the alcohol ethoxylate type of surfactant, or an ionic formulation. In accordance with various exemplary aspects of this embodiment, the 2-ethylhexyl ester component is present in an amount of about 0.1 to about 99 weight percent, preferably about 10 to about 99 weight percent, and more preferably about 70 to about 99 weight percent; and the surfactant is present in the amount of about 1 to about 50 weight percent, preferably about 2 to about 40 weight percent, and more preferably about 5 to about 30 weight percent (e.g., about 10 to about 30 weight percent).

In accordance with yet another embodiment of the invention, a composition includes a 2-ethylhexyl ester component, a co-solvent, a surfactant, and a diluent such as water. In accordance with this embodiment, the 2-ethylhexyl ester component is present in an amount of about 1 to about 99 weight percent, preferably about 5 to about 99 weight percent, and more preferably about 10 to about 90 weight percent; the surfactant is present in an amount of about 0 to about 60 weight percent, preferably about 1 to about 50 weight percent, and more preferably about 10 to about 40; the diluent is present in the amount of about 0 to about 50 weight percent, preferably about 0 to about 40 weight percent, and more preferably about 1 to about 30 weight percent; and the co-solvent is present in the amount of about 1 to about 20 weight percent, preferably about 1 to about 15 weight percent, and more preferably about 1 to about 10 weight percent.

In accordance with additional embodiments of the invention, a composition for cleaning and degreasing is formed by admixing a 2-ethylhexyl ester component with an additional component. In accordance with various aspects of these embodiments, the additional component is a diluent, such as water, a co-solvent, such as bio diesel, or a surfactant such as an alcohol ethoxylate type surfactant.

In accordance with yet another embodiment of the invention, a method of cleaning and degreasing includes providing a substrate and applying a composition including a 2-ethylhexyl ester to the substrate. The method may also include the step of rinsing.

In accordance with another embodiment of the invention, a system for recycling cleaning and degreasing compositions includes a chamber for receiving used cleaning and degreasing solution and pressurized gas. In accordance with various aspects of this embodiment, the system also includes a vessel for cleaning substrates and a depressurization unit. The system can be used to clean substrates and recycle the cleaning and degreasing composition, thereby reducing an amount of composition required to clean and/or degrease the substrates.

In accordance with yet another embodiment of the invention, a method of recycling a cleaning and degreasing composition includes cleaning a substrate using a cleaning and degreasing composition, exposing the spent cleaning and degreasing composition to a pressurized gas to cause waste in the spent cleaning and degreasing solution to become less soluble in the composition, removing the waste, and depressurizing the separated solution.

Brief Description of The Drawings

The exemplary embodiments of the present invention will be described in connection with the appended drawing figures in which like numerals denote like elements and:

Figure 1 illustrates a block diagram of an exemplary system for recycling a cleaning and degreasing composition in accordance with one embodiment of the invention;

Figure 2 illustrates a block diagram of another exemplary system for recycling a cleaning and degreasing composition in accordance with another embodiment of the invention; and

Figure 3 illustrates a block diagram of yet another exemplary system for recycling a cleaning and degreasing composition in accordance with a further embodiment of the invention.

Detailed Description

The present invention provides a composition for cleaning and degreasing substrates, methods of forming and using the composition, and a system for using and recycling the composition. The composition of the present invention can be used to remove substances such as crude oil, asphalt and asphalt constituents such as bitumen and asphaltenes, tar, sludge, grease, inks, hydraulic fluids, lubricating oils, grime, carbon deposits, and other materials from a substrate.

The composition and methods described herein may be used to clean and degrease a variety of substrates. For example, the composition can be used as a degreaser to clean equipment typically used in the manufacture or processing of asphalt, a graffiti remover, an ink remover, a gun cleaner, and an automotive parts cleaner. However, the invention is generally described below in connection with removing asphalt and asphalt constituents from equipment. Those skilled in the art will appreciate that the compositions and methods of the present invention are not limited to the specific examples provided herein. For example, the compositions and methods of the present invention may be used to remove substances from other substrates, such as liquids, solids, semi-liquids, and semisolids. The substrates may be organic or inorganic materials such as sand, metal or ceramic materials.

Exemplary compositions in accordance with embodiments of the present invention are environmentally benign (*i.e.*, non-toxic, biodegradable (about 80% in about 28 days) and have less VOC compared to other similar compositions), have a relatively high flash point, have relatively low odor, and are and relatively efficient at cleaning and degreasing.

The compositions of the present invention include a 2-ethylhexyl ester compound and may include additional constituents such as surfactants, co-solvents, and diluents as set forth in more detail below. In addition, the compositions may include optional adjuvants or inert compounds such as disinfectants—*e.g.*, s ester quats and quaternary ammonium compounds that are non-toxic and readily biodegradable, quaternary ammonium salts of diglycol amine salts with various types of carboxylic acids, and/or salicylic acid, cinnamic acid, benzoic acid, tartaric acid, citric acid, oxalic acid, alginic acid, carboxy methyl cellulose, carboxy ethyl cellulose, and acetic acid, biodegradable food grade colorant, food grade fragrance, and the like.

Exemplary 2-ethylhexyl ester compounds suitable for use with compositions of the present invention include 2-ethylhexylbenzoate, 2-ethylhexylcinnamate, 2-

ethylhexylsalicylate, 2-ethylhexyloleate, 2-ethylhexylpalmitate, 2-ethylhexyladipate, 2-ethylhexylstearate, 2-ethylhexylsuccinate, and other like 2-ethylhexyl ester compounds.

In accordance with one exemplary embodiment of the invention, a composition for cleaning and degreasing includes one or more 2-ethylhexyl ester components and may additionally include a co-solvent. This composition is particularly useful for removing asphalt and sealants from substrates. In accordance with various aspects of this embodiment, the composition includes a co-solvent such as bio diesel, propylene glycol monomethyl ether, dipropylene glycol monomethyl ether, tripropylene glycol monomethyl ether, dipropylene glycol n-propyl ether, tripropylene glycol n-propyl ether, propylene glycol n-butyl ether, dipropylene glycol n-butyl ether, tripropylene glycol n-butyl ether, and dipropylene glycol dimethyl ether; fatty acids methyl esters such as methyl stearate ester, methyl oleate ester, methyl palmitate ester, methyl soyate ester, methyl linoleate ester, and methyl linoleate ester; fatty acid amides with diglycolamine; fatty acids amine salts with diglycolamine; and the like. However, in accordance with an alternative embodiment, the composition includes substantially 100 percent 2-ethylhexyl ester. In accordance with various aspects of the embodiment, the composition includes about 1 to about 100 weight percent, preferably about 80 to about 100 weight percent, and more preferably about 95 to about 100 weight percent 2-ethylhexyl ester—for example, about 98 to about 99.5 weight percent; and about 0 to about 99 weight percent, preferably about 0 to about 20 weight percent, and more preferably about 0.5 to about 2 weight percent of a co-solvent such as bio diesel.

In accordance with another embodiment of the invention, a composition includes a 2-ethylhexyl ester component and a surfactant. The surfactant increases the rinseability of the composition, which may be desirable when the composition is used to clean substrates such as asphalt processing equipment. In particular, it may be desirable to rinse the composition from asphalt or other processing equipment, because the cleaning composition may have deleterious effects—*e.g.*, stripping of bitumen of asphalt—on materials placed in the equipment after cleaning.

Surfactants suitable for use with compositions of the present invention include nonionic and ionic surfactants. Exemplary nonionic surfactants include alcohol ethoxylate type of surfactants, having an alcohol carbon chain length ranging from C₁ to C₂₄ and preferably from C₆ to C₁₈; and more preferably from C₉ to C₁₁ alcohol ethoxylated with from 1 to 28 units of ethylene oxide molecules and preferably from 1 to 10 ethylene oxide

molecules, and more preferably from 1 to 6 ethylene oxide molecules. Other examples of surfactants are ethoxylated sugar alcohols, such as sorbitol and manitol, and the like. Exemplary ionic surfactants include alcohol sulfates, alcohol sulfonates, sulfosuccinates, sulfated fatty acids, and the like.

In accordance with various aspects of this embodiment, the 2-ethylhexyl ester component is present in an amount of about 0.1 to about 100 weight percent, preferably about 10 to about 100 weight percent, and more preferably about 70 to about 100 weight percent; and the surfactant is present in the amount of about 1 to about 40 weight percent, preferably about 1 to about 30 weight percent, and more preferably about 1 to about 25 weight percent.

In accordance with yet another embodiment of the invention, a composition includes a 2-ethylhexyl ester component, a surfactant, a co-solvent, and a diluent. Suitable diluents for use with compositions of the present invention include water.

In accordance with this embodiment, the 2-ethylhexyl ester component is present in an amount of about 1 to about 99 weight percent, preferably about 5 to about 99 weight percent, and more preferably about 10 to about 99 weight percent; the diluent is present in the amount of about 0 to about 50 weight percent, preferably about 0 to about 40 weight percent, and more preferably about 1 to about 30 weight percent; the surfactant is present in the amount of about 0 to about 60 weight percent, preferably about 1 to about 50 weight percent, and more preferably about 10 to about 40 weight percent; and the co-solvent is present in the amount of about 1 to about 20 weight percent, preferably about 1 to about 15 weight percent, and more preferably about 1 to about 10 weight percent.

In accordance with another embodiment of the invention, a method of cleaning a substrate includes applying a composition including a 2-ethylhexyl ester to a substrate. In accordance with various additional aspects of this embodiment, the method includes applying a composition including a 2-ethylhexyl ester and a co-solvent, a 2-ethylhexyl ester and a surfactant, a 2-ethylhexyl ester and a diluent, and various combinations thereof. Methods of cleaning may also further include rinsing the substrate with, for example, water. The following non-limiting examples illustrate specific exemplary compositions in accordance with various embodiments of the invention. These examples are merely illustrative, and it is not intended that the invention be limited to these examples. Compositions in accordance with the present invention may include the ingredients listed

below as well as additional and/or alternative inert materials, surfactants, and other constituents typically found in compositions for cleaning or degreasing.

Example 1

An exemplary composition was formed by admixing about 99 wt% 2-ethylhexyl benzoate and about 1% methyl soyate. The asphalt removal efficiency of this formulation is about 50% better than diesel fuel.

Example 2

Another exemplary composition was formed by admixing about 80 wt% 2-ethylhexyl benzoate and about 20 wt% alcohol ethoxylate surfactant C₉-C₁₁ alcohol ethoxylated with 4 ethylene oxide units. The asphalt removal efficiency of this formulation is about 50% better than diesel fuel and it is rinsable with water.

Example 3

Yet another exemplary composition was formed by admixing about 33.33 wt% 2-ethylhexyl benzoate, about 11.10 wt% dipropylene glycol monomethyl ether, about 55.56 wt% alcohol ethoxylate surfactant C₉-C₁₁ alcohol ethoxylated with 4 ethylene oxide units. This formulation can form a microemulsion with water which can be added up to 60 % water and still be effective in degreasing surfaces from oils and greases.

In accordance with additional embodiments of the present invention, a method and system for recycling a used cleaning composition includes the use of dense gases create an anti-solvent effect. The used solvent is recycled through the use of supercritical fluids/compressed gases which impart a new solubility parameter value for the solvents, for example to expand the used solvent, thus decreasing the ability for the solvents to hold the solute wastes, such as dissolved greases, bitumen, and the like, and leaving the wastes insoluble. The compressed gas/solvent mixture can then be decompressed, resulting in gas separation from the solvent and allowing for recycling of the gas and solvents.

Figure 1 illustrates a system 100 for recycling cleaning compositions in accordance with various embodiments of the invention. System 100 includes a first vessel 102 for cleaning materials, parts and components, such as fabrics, machinery, metal parts and the like and a second vessel 104 for pressurization of the used solvent and wastes with dense

gases. Although illustrated with a first vessel 102, systems in accordance with other embodiments of the invention do not require a cleaning vessel. In such cases, the cleaning composition is pumped or placed directly in pressurized vessel 104.

First vessel 102 can comprise any conventional vessel used for cleaning of materials, parts or components. Exemplary vessels suitable for first vessel 102 include a closed stainless steel vessel for use with fabrics.

Vessel 104 can comprise any pressurized vessel or chamber configuration capable of pressures ranging from approximately 100-3000 psi or more, and operating at a temperature ranging from approximately 10-70 degrees Celsius. For example, vessel 104 may be a countercurrent separation column suitable for operating at these pressures and temperatures.

In operation, system 100, parts are cleaned in vessel 102 and the used cleaner and waste is transferred to vessel 104. Dense gas or a dense gas mixture is then introduced to vessel 104 to a pressure of about 100-3000 psi at a temperature of about 10-70 degrees Celsius. Exemplary dense gases suitable for use with this embodiment include methane, ethane, propane, butane, carbon dioxide, ammonia, or mixtures of these components. The dense gases can also contain traces of alcohols such as ethanol, methanol, iso-propanol, n-propanol, iso-butanol, and n-butanol.

After separation of the waste from the solvent/gas mixture, the solvent can be separated from the dense gas or dense gas mixtures through depressurization, which may be performed in vessel 104. This allows the dense gases to be recycled back to vessel 104 and the cleaning solution to be recycled back for use again in cleaning vessel 102.

System 100 allows for substantially all of the dense gases and solvents to be recovered. For example, depending on the chemical nature of the dense gases and solvents, approximately 97% or more of the gases and solvents can be recycled, with the purity of the solvent reaching about 99.99% of its original state in many applications.

Figure 2 illustrates another system 200 for recycling cleaning solutions in accordance with various embodiments of the invention. System 200 includes a vessel 204 for subjecting the used cleaning composition to compressed gas, a depressurization unit 206, and optionally includes a filter 208 and a separator 210. Vessel 204 may be the same as vessel 104 described above in connection with system 100. Optional depressurization unit 206 may include any vessel suitable for reducing the pressure of the gas/cleaning composition mixture. Optional filter 208 may include any desired filter compatible with the

compositions of the present invention. The separator 210 may include, for example, a spinning band distillation column to further separate the waste from the cleaning solution.

System 200 operates in generally the same manner as system 100. Used cleaning composition with waste is fed to a vessel 204. The composition may be fed directly into vessel 204 or the solution may be filtered using filter 208. Pressurized gas is then fed into vessel 204, which decreases the solubility of waste in the cleaning solution. Waste is removed from the solution at this point. The cleaning solution/gas mixture is then fed to depressurization unit 206 to separately recover the gas and the cleaning solution. Some of the cleaning solution/waste mixture may also be fed to unit 210 to further separate any waste remaining in the cleaning solution.

Figure 3 illustrates yet another exemplary recycling system 300, which includes a first cleaning chamber 302, a pressure chamber 304, a depressurization unit 306, a gas compressor 308, a gas tank 310, a solvent recycling pump 312 and a solvent reservoir 314. System 300 may also comprise various other fluid pumps and control valves configured to perform functions that facilitate recycling.

During operation, the material/object to be cleaned is mixed with the solvent in the cleaning chamber 302 that optionally provides agitation and mixing. After the washing cycle is finished, the cleaning solution plus the wastes that are removed from the material are pumped to pressure chamber 304, where dense gas or gas mixtures are compressed into chamber 304 and mixed with the solvent containing the wastes. The compressed gas dissolves in the cleaning solution leaving the wastes insoluble therein. The wastes can then be removed (*e.g.*, for disposal, incineration, or purification), and the dense gas/cleaning solution mixture is then sent to depressurization chamber 306. In depressurizing chamber 306, the pressure is gradually released, which results in the gas separating from the solvent. The dense gas and mixtures can then be recompressed in gas compressor 308 and returned to gas tank 310 for recycled usage. Similarly, the cleaning composition can be pumped through solvent recycling pump 312 back to solvent reservoir for storage and further use.

The present invention sets forth cleaning compositions that are relatively non-toxic, biodegradable, non-corrosive to most metals, non-explosive, non-flammable, and have minimal or no VOC and HPA and methods of using and recycling the compositions. It will be understood that the foregoing description is of exemplary embodiments of the invention, and that the invention is not limited to the specific illustrative compositions, methods, and systems. Various modifications may be made in the actual compositions and methods set

forth herein without departing from the scope of the invention. These and other changes or modifications are intended to be included within the scope of the present invention.

CLAIMS:

I claim:

1. A composition for cleaning and degreasing, the composition consisting essentially of a 2-ethylhexy ester and one or more components selected from the group consisting of a diluent, a surfactant, and a co-solvent.
2. The composition of claim 1, wherein the 2-ethylhexyl ester is selected from the group consisting of 2-ethylhexylbenzoate, 2-ethylhexylcinnamate, of 2-ethylhexylsalicylate, 2-ethylhexyloleate, 2-ethylhexylpalmitate, 2-ethylhexyladipate, 2-ethylhexylstearate, and 2-ethylhexylsuccinate.
3. The composition of claim 1, wherein the one or more components comprise a co-solvent.
4. The composition of claim 3, wherein the co-solvent includes a compound selected from the group consisting of propylene glycol monomethyl ether, dipropylene glycol monomethyl ether, tripropylene glycol monomethyl ether, dipropylene glycol n-propyl ether, tripropylene glycol n-propyl ether, dipropylene glycol n-butyl ether, propylene glycol n-butyl ether, tripropylene glycol n-butyl ether, dipropylene glycol dimethyl ether, fatty acids methyl esters, and fatty acid amids.
5. The composition of claim 4, wherein the co-solvent is selected from the group consisting of methyl stearate ester, methyl oleate ester, methyl palmitate ester, methyl soyate ester, methyl linoleate ester, and methyl linoleneate ester.
6. The composition of claim 1, wherein the one or more components comprise a surfactant.
7. The composition of claim 6, wherein the surfactant is a nonionic surfactant.
8. The composition of claim 7, wherein the nonionic surfactant comprises an alcohol ethoxylate.

9. The composition of claim 8, wherein the alcohol ethoxylate carbon chain length ranges from C₁-C₂₄.
10. The composition of claim 8, wherein the alcohol ethoxylate carbon chain length ranges from C₆ to C₁₈ and it has from 1 to 10 ethylene oxide units.
11. The composition of claim 7, wherein the nonionic surfactant is a sugar alcohol.
12. The composition of claim 11, wherein the surfactant is selected from the group consisting of sorbitol and manitol.
13. The composition of claim 1, wherein the one or more components comprise a diluent.
14. The composition of claim 13, wherein the diluent is water.
15. A composition for cleaning and recycling comprising:
about 0.5 to about 2 weight percent co-solvent; and
about 70 to about 99.5 weight percent 2-ethylhexyl ester.
16. A composition for cleaning and recycling comprising:
about 5 to about 30 weight percent surfactant; and
about 70 to about 90 weight percent 2-ethylhexyl ester.
17. A composition for cleaning and recycling comprising:
about 0 to about 50 weight percent diluent;
about 1 to 50 weight percent surfactant;
about 1 to about 20 co-solvent; and
about 10 to about 99 weight percent 2-ethylhexyl ester.
18. A method of cleaning a substrate, the method comprising the steps of:
providing a cleaning solution comprising a 2-ethylhexyl ester; and

applying the cleaning solution to a substrate.

19. A system for recycling a cleaning solution, the system comprising:
a cleaning solution comprising 2-ethylhexyl ester; and
a chamber configured to receive the cleaning solution mixed with waste and a pressurized gas.
20. The system of claim 19, further comprising a depressurization unit.
21. The system of claim 19, further comprising a filter.
22. The system of claim 19, further comprising a distillation unit.
23. A method of recycling a cleaning solution, the method comprising the steps of:
providing a 2-ethylhexyl ester solution;
applying the 2-ethylhexyl ester solution to a substrate to create a mixture of 2-ethylhexyl ester and waste;
supplying the mixture to a pressure chamber;
adding pressurized gas to the mixture in the pressure chamber;
removing the waste; and
depressurizing a combination of 2-ethylhexyl ester and gas.

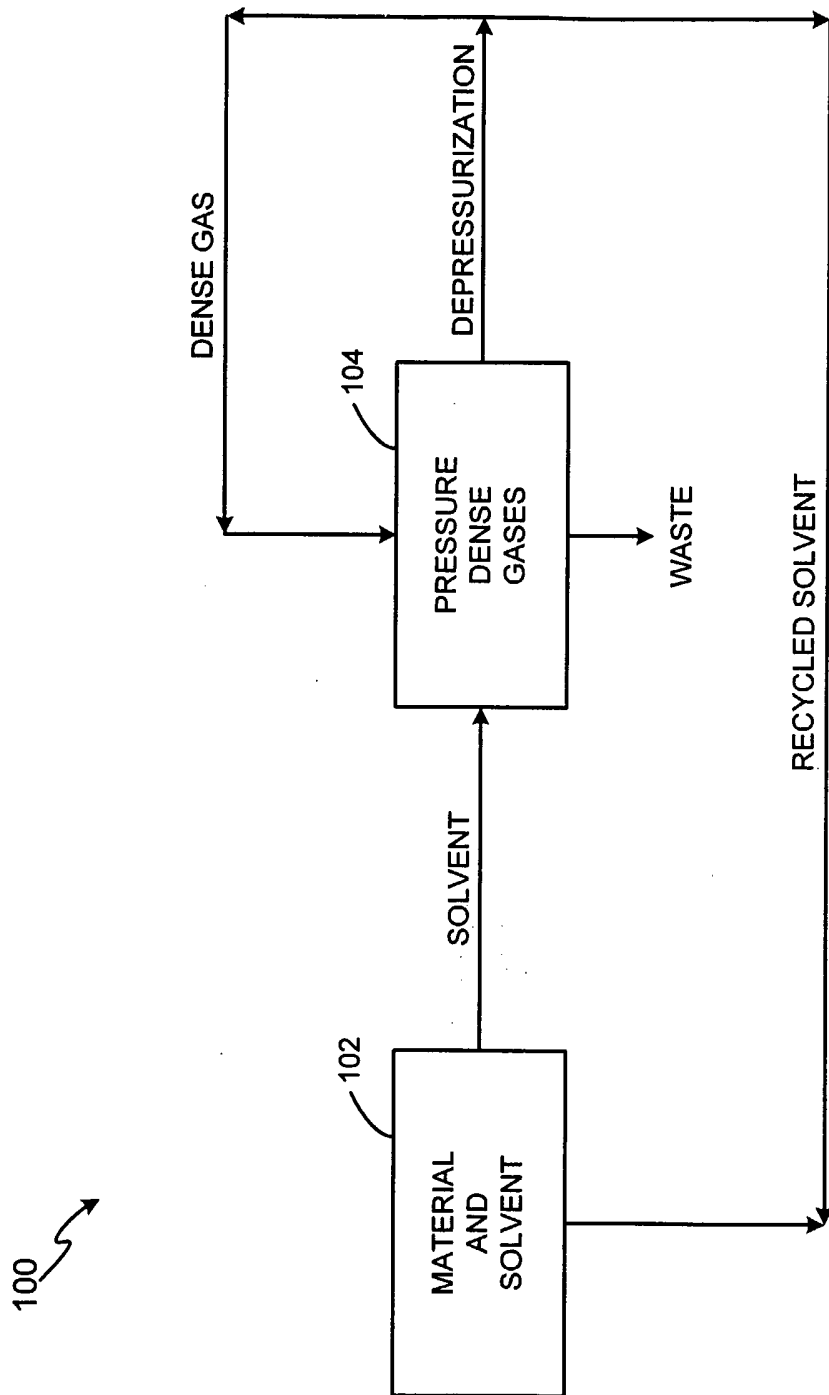

FIGURE 1

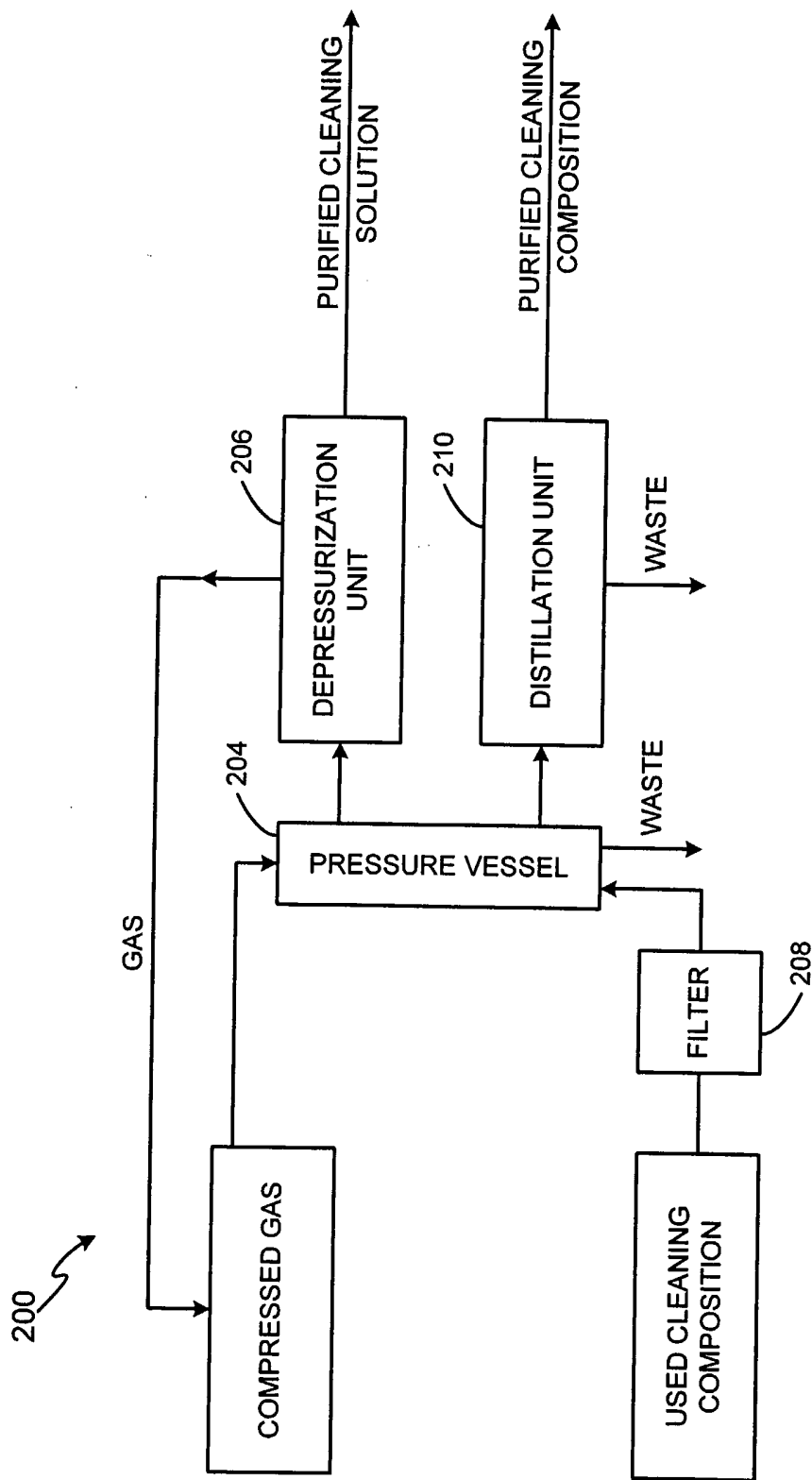

FIGURE 2

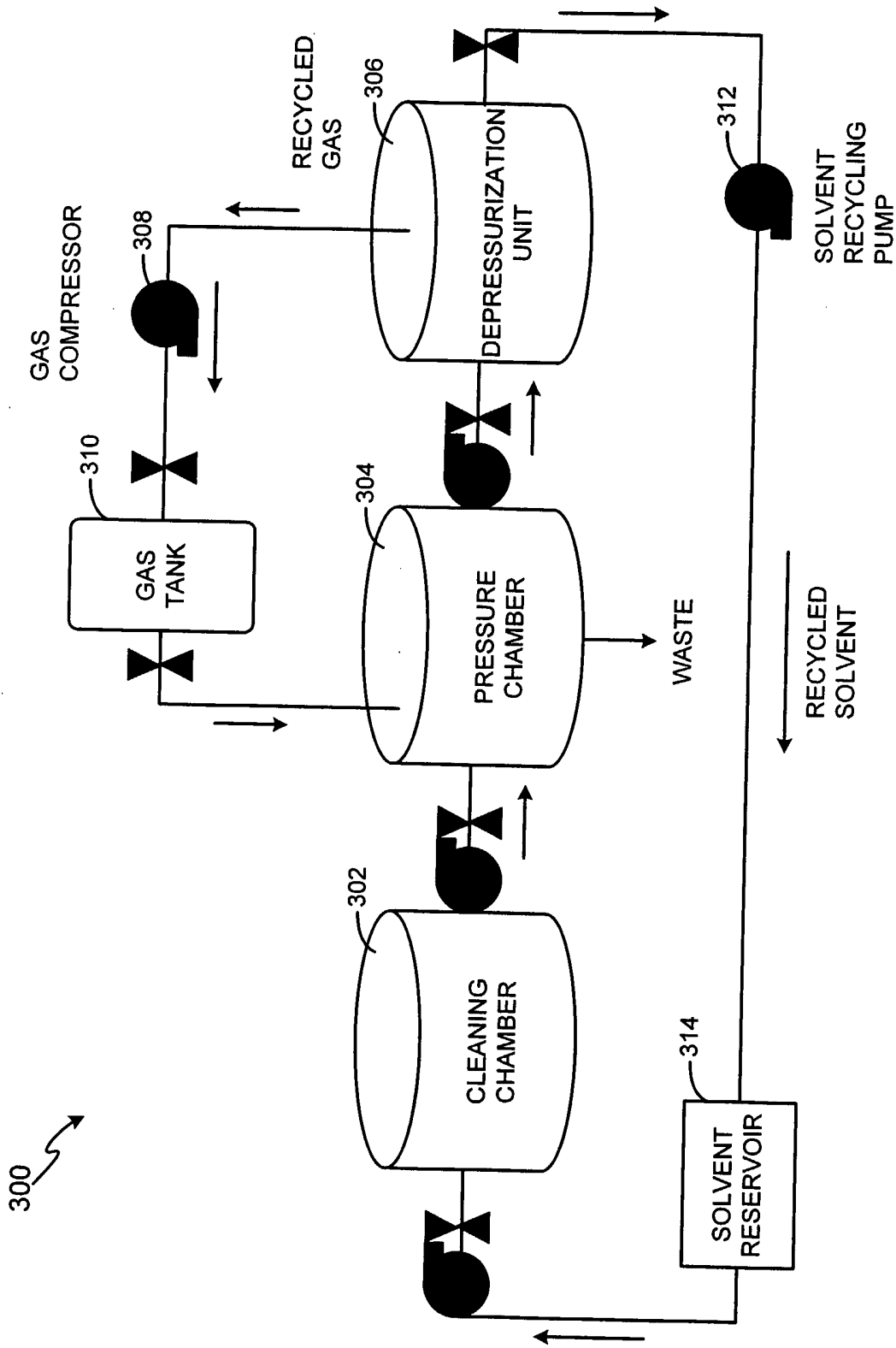

FIGURE 3

INTERNATIONAL SEARCH REPORT

International Application No
PCT/US2005/036908

A. CLASSIFICATION OF SUBJECT MATTER
 C23G5/032 C11D3/20 C11D3/43 C11D7/50 C11D1/72
 C11D1/66 C11D11/00

According to International Patent Classification (IPC) or to both national classification and IPC

B. FIELDS SEARCHED
 Minimum documentation searched (classification system followed by classification symbols)
 C23G C11D

Documentation searched other than minimum documentation to the extent that such documents are included in the fields searched

Electronic data base consulted during the international search (name of data base and, where practical, search terms used)
 EPO-Internal

C. DOCUMENTS CONSIDERED TO BE RELEVANT

Category °	Citation of document, with indication, where appropriate, of the relevant passages	Relevant to claim No.
X	WO 92/20835 A (HENKEL KOMMANDITGESELLSCHAFT AUF AKTIEN) 26 November 1992 (1992-11-26) page 3, line 6 - last line ; table 1 claims 1,-10	1, 3, 4, 6-10, 13-18
X	EP 0 498 545 A (DU PONT LIMITED) 12 August 1992 (1992-08-12) claims 1,5-9; examples 4,7	1,3, 6-14,17, 18
X	US 5 482 645 A (MARUYAMA ET AL) 9 January 1996 (1996-01-09)	1,6,7, 11,12,18
Y	column 2, line 42 - column 3, line 21; claims 1,2,6; tables a,c	19-21,23
	-/--	

Further documents are listed in the continuation of box C. Patent family members are listed in annex.

° Special categories of cited documents :

- *A* document defining the general state of the art which is not considered to be of particular relevance
- *E* earlier document but published on or after the international filing date
- *L* document which may throw doubts on priority claim(s) or which is cited to establish the publication date of another citation or other special reason (as specified)
- *O* document referring to an oral disclosure, use, exhibition or other means
- *P* document published prior to the international filing date but later than the priority date claimed
- *T* later document published after the international filing date or priority date and not in conflict with the application but cited to understand the principle or theory underlying the invention
- *X* document of particular relevance; the claimed invention cannot be considered novel or cannot be considered to involve an inventive step when the document is taken alone
- *Y* document of particular relevance; the claimed invention cannot be considered to involve an inventive step when the document is combined with one or more other such documents, such combination being obvious to a person skilled in the art.
- * & * document member of the same patent family

Date of the actual completion of the international search 17 January 2006	Date of mailing of the international search report 03/02/2006
--	--

Name and mailing address of the ISA European Patent Office, P.B. 5818 Patentlaan 2 NL - 2280 HV Rijswijk Tel. (+31-70) 340-2040, Tx. 31 651 epo nl, Fax: (+31-70) 340-3016	Authorized officer Loiselet-Taisne, S
--	--

INTERNATIONAL SEARCH REPORT

International Application No

PCT/US2005/036908

C.(Continuation) DOCUMENTS CONSIDERED TO BE RELEVANT

Category °	Citation of document, with indication, where appropriate, of the relevant passages	Relevant to claim No.
X	WO 01/90291 A (IMPERIAL CHEMICAL INDUSTRIES PLC; MOTSON, HAROLD, RUSSELL) 29 November 2001 (2001-11-29) page 11, line 13; claims 1-3,5; examples 4.2,4.3,4.5,4.6,4.8,5; tables 4,5 page 9, line 34 - line 38 -----	1-3,6-8, 13,14,18
X	US 6 010 995 A (VAN EENAM ET AL) 4 January 2000 (2000-01-04) claims 1,11; example 25 -----	1,2,6-8, 13,14,18
Y	WO 03/072215 A (NORTH CAROLINA STATE UNIVERSITY; CARBONELL, RUBEN, GUILLERMO; KILPATRI) 4 September 2003 (2003-09-04) page 11, line 1, paragraphs 81,90 - line 2; claims 1-34,50-71,84-103; examples 4,7,22,23 -----	19-21,23

INTERNATIONAL SEARCH REPORT

Information on patent family members

International Application No

PCT/US2005/036908

Patent document cited in search report	A	Publication date	Patent family member(s)	Publication date
WO 9220835	A	26-11-1992	AT 134725 T	15-03-1996
			DE 4116580 A1	26-11-1992
			DK 587594 T3	24-06-1996
			EP 0587594 A1	23-03-1994
			ES 2083742 T3	16-04-1996
			JP 6507673 T	01-09-1994
			US 5421907 A	06-06-1995
			<hr/>	
EP 0498545	A	12-08-1992	AT 128672 T	15-10-1995
			AU 1050692 A	06-08-1992
			BR 9200264 A	06-10-1992
			CA 2060266 A1	30-07-1992
			DE 69205184 D1	09-11-1995
			DE 69205184 T2	07-03-1996
			ES 2080438 T3	01-02-1996
			FI 920358 A	30-07-1992
			IE 920273 A1	29-07-1992
			JP 5246018 A	24-09-1993
			NO 920373 A	30-07-1992
			US 5194173 A	16-03-1993
			ZA 9200518 A	28-10-1992
<hr/>				
US 5482645	A	09-01-1996	JP 7026294 A	27-01-1995
<hr/>				
WO 0190291	A	29-11-2001	AU 6043901 A	03-12-2001
			EP 1287099 A1	05-03-2003
			JP 2003534448 T	18-11-2003
<hr/>				
US 6010995	A	04-01-2000	NONE	
<hr/>				
WO 03072215	A	04-09-2003	AU 2003216422 A1	09-09-2003
			EP 1490469 A2	29-12-2004
<hr/>				