

(12) STANDARD PATENT
(19) AUSTRALIAN PATENT OFFICE

(11) Application No. **AU 2004247143 B2**

(54) Title
Osteoimplants and methods for their manufacture

(51) International Patent Classification(s)
A61F 2/00 (2006.01) *A61F 2/30* (2006.01)
A61F 2/28 (2006.01) *A61F 2/44* (2006.01)
A61F 2/46 (2006.01)

(21) Application No: **2004247143** (22) Date of Filing: **2004.06.10**

(87) WIPO No: **WO04/110308**

(30) Priority Data

(31) Number (32) Date (33) Country
60/478,130 **2003.06.11** **US**

(43) Publication Date: **2004.12.23**

(44) Accepted Journal Date: **2010.09.23**

(71) Applicant(s)
Osteotech, Inc.

(72) Inventor(s)
Morris, John W.;Watson, Kimberly D.;Yoncak, Richard Anthony;Burel, Marc Henry;Quackenbush, David F.;Forsyth, Nanette;Clark, Chris H.;Traianedes, Kathy

(74) Agent / Attorney
Watermark Patent and Trade Marks Attorneys, Level 2 302 Burwood Road, Hawthorn, VIC, 3122

(56) Related Art
US 6,123,731

(19) World Intellectual Property
Organization
International Bureau



(43) International Publication Date
23 December 2004 (23.12.2004)

PCT

(10) International Publication Number
WO 2004/110308 A2

- (51) International Patent Classification⁷: A61F
- (21) International Application Number: PCT/US2004/018618
- (22) International Filing Date: 10 June 2004 (10.06.2004)
- (25) Filing Language: English
- (26) Publication Language: English
- (30) Priority Data: 60/478,130 11 June 2003 (11.06.2003) US
- (71) Applicant (for all designated States except US): OS-TEOTECH, INC. [US/US]; 51 James Way, Eatontown, NJ 07724 (US).
- (72) Inventors; and
- (75) Inventors/Applicants (for US only): BUREL, Marc, Henry [US/US]; 6 James Terrace, Towaco, NJ 07082 (US).

CLARK, Chris, H. [US/US]; 39 Little Street, Matawan, NJ 07747 (US). FORSYTH, Nanette [US/US]; 226 Lakewood Avenue, Bayville, NJ 08721 (US). MORRIS, John, W. [US/US]; 608 Beach Avenue, Beachwood, NJ 08722 (US). QUACKENBUSH, David, F. [US/US]; 9 Briar Hill Drive, Manalapan, NJ 07726 (US). TRAIANEDES, Kathy [AU/AU]; 74 Nirvana Avenue, Malvern East VIC. 3145 (AU). WATSON, Kimberly, D. [US/US]; 55 East Kings Highway, Apt. 603, Maple Shade, NJ 08052 (US). YONCAK, Richard, Anthony [US/US]; 168 Pinetree Court, Howell, NJ 07731 (US).

(74) Agents: DILWORTH, Peter, G. et al.; Dilworth & Barse, LLP, 333 Earle Ovington Boulevard, Uniondale, NY 11553 (US).

(81) Designated States (unless otherwise indicated, for every kind of national protection available): AE, AG, AL, AM, AT, AU, AZ, BA, BB, BG, BR, BW, BY, BZ, CA, CH, CN, CO, CR, CU, CZ, DE, DK, DM, DZ, EC, EE, EG, ES, FI,

[Continued on next page]

(54) Title: OSTEOIMPLANTS AND METHODS FOR THEIR MANUFACTURE

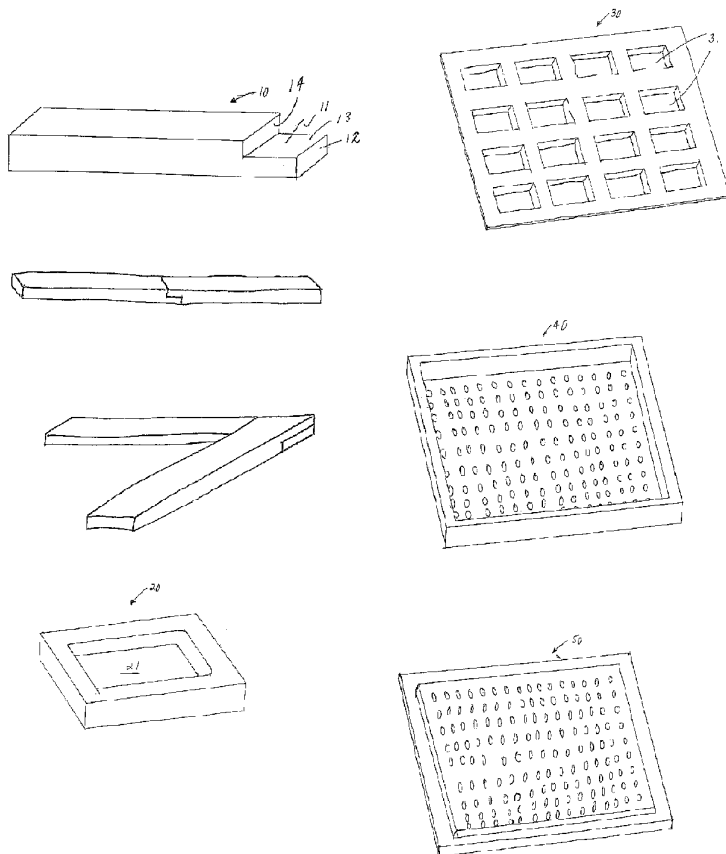

(57) Abstract: An osteoimplant is made up of a coherent aggregate of elongate bone particles.

WO 2004/110308 A2



GB, GD, GE, GH, GM, HR, HU, ID, IL, IN, IS, JP, KE, KG, KP, KR, KZ, LC, LK, LR, LS, LT, LU, LV, MA, MD, MG, MK, MN, MW, MX, MZ, NA, NI, NO, NZ, OM, PG, PH, PL, PT, RO, RU, SC, SD, SE, SG, SK, SL, SY, TJ, TM, TN, TR, TT, TZ, UA, UG, US, UZ, VC, VN, YU, ZA, ZM, ZW.

(84) Designated States (unless otherwise indicated, for every kind of regional protection available): ARIPO (BW, GH, GM, KE, LS, MW, MZ, NA, SD, SL, SZ, TZ, UG, ZM, ZW), Eurasian (AM, AZ, BY, KG, KZ, MD, RU, TJ, TM), European (AT, BE, BG, CH, CY, CZ, DE, DK, EE, ES, FI,

FR, GB, GR, HU, IE, IT, LU, MC, NL, PL, PT, RO, SE, SI, SK, TR), OAPI (BF, BJ, CF, CG, CI, CM, GA, GN, GQ, GW, ML, MR, NE, SN, TD, TG).

Published:

— without international search report and to be republished upon receipt of that report

For two-letter codes and other abbreviations, refer to the "Guidance Notes on Codes and Abbreviations" appearing at the beginning of each regular issue of the PCT Gazette.

OSTEOIMPLANTS AND METHODS FOR THEIR MANUFACTURECROSS REFERENCE TO RELATED APPLICATION

This application claims the benefit of provisional U.S. patent application Serial No.
5 60/478,130, filed June 11, 2003, the entire contents of which are incorporated by reference
herein.

BACKGROUND OF THE INVENTION

1. Field of the Invention

This invention relates to bone-derived implants, or osteoimplants, made up of a
10 coherent aggregate of elongate bone particles and to methods for their manufacture. Among
their many applications, the osteoimplants herein can be fashioned in various configurations
and sizes for use in repairing bone defects, e.g., as strips for use in spinal fusion procedures,
as trough-shaped implants especially useful for PostLateral Fusion ("PLF") procedures, and
as putty-like materials that can be molded on site and packed between fragments of bone
15 fractures, between bony projections and into large cavities.

2. Description of the Related Art

Bone-derived implants have been used extensively to treat various medical problems
in human and animal orthopedic surgical practice. The use of such implants has also extended
to the fields of, e.g., cosmetic and reconstructive surgery, dental reconstructive surgery,
20 podiatry, orthopaedics, neurosurgery and other medical fields involving hard tissue. The use
of autograft bone (where the patient provides the source), allograft bone (where another
individual of the same species provides the source) or xenograft bone (where another
individual of a different species provides the source) is well known in both human and
veterinary medicine. In particular, transplanted bone is known to provide support, promote
25 healing, fill bony cavities, separate bony elements (such as vertebral bodies), promote fusion

(where bones are induced to grow together into a single, solid unit) or st
fractures. More recently, processed bone has been developed into shapes for use in new
surgical applications or as new materials for implants that were historically based on non-
biologically derived materials.

5 Osteoconductive materials are ones that guide bone growth but do not stimulate it.
Examples are bone chips and ceramics. Osteoinductive materials actually cause bone to form
and result in faster and more certain healing. Examples of osteoinductive materials include
cancellous bone, demineralized bone and various growth factors. The most common source
of osteoinductive material is the patient's own bone. Typically, in spinal surgery, this is
10 harvested from the iliac crest in the form of bone chips and marrow. While effective, it
causes secondary damage (to the harvest site) and requires preparation before it can be used.
Furthermore, it is somewhat difficult to maintain in place due to its semi-fluid nature.

 Demineralized bone is an alternative to bone chips and marrow as an osteoinductive
material. Compositions containing demineralized bone come in various forms including gels,
15 pastes, fibers, sheets, and the like. The more fluid compositions such as those made with
bone powder are relatively easy to implant at the repair site but difficult to maintain in place.
Osteoimplants made with elongate bone particles, in contrast to those made from bone
powder, are better able to maintain their implanted shape and mass and to resist or delay
erosion by body fluids and irrigation liquids. Elongate bone particles and methods for their
20 manufacture are described in, *inter alia*, U.S. Patent Nos. 5,314,476, 5,507,813, 5,607,269
and 6,436,138, in pending U.S. patent application Serial No. 10/137,862, filed May 2, 2002
(attorney docket 285-158 PCT CIP) and WO 03/082159.

SUMMARY OF THE INVENTION

 It is an object of the invention to provide osteoimplants derived from elongate bone
25 particles.

It is a particular object of the invention to provide an osteoimplar shape and dimensions made up of a coherent aggregate of elongate bone particles.

It is another particular object of the invention to provide a low density osteoimplant which possesses an open pore structure allowing the osteoimplant to readily absorb fluids
5 such as blood and yet still retain its original shape.

It is another object of the invention to provide an osteoimplant fabricated from elongate bone particles which is flexible when water has been removed and which can be implanted while in the dry state.

It is yet another object of the invention to provide methods for making osteoimplants
10 possessing the aforementioned characteristics.

It is still another object of the invention to provide methods of treating bone defects which utilize osteoimplants possessing the aforementioned characteristics.

Other specific objects of the invention include the provision of an osteoimplant in the form of a strip and the use of the strip, e.g., in a spinal fusion procedure such as one to treat
15 scoliosis.

Yet another specific object of the invention is the provision of an osteoimplant in the form of a putty-like material which can be readily molded by the surgeon during a surgical procedure so as to conform to a bone repair site.

Still another specific object of the invention is the provision of a method for making a
20 trough-shaped osteoimplant.

The term "osteoimplant" as utilized herein is intended to refer to any device or material for implantation that aids or augments bone formation or healing. Osteoimplants are often applied at a bone defect site, e.g., one resulting from injury, defect brought about during the course of surgery, infection, malignancy or developmental malformation. The
25 osteoimplants herein may be suitably sized and shaped as required for use in any of a wide

variety of orthopedic, neurosurgical and oral and maxillofacial surgical procedures, the repair of simple and compound fractures and non-unions, external and internal fixations, joint reconstructions such as arthrodesis, general arthroplasty, deficit filling, discectomy, laminectomy, anterior cervical and thoracic operations, spinal fusions, etc. Therefore, the osteoimplants herein are intended for implantation at a bony site and are made of any biocompatible material(s), e.g., bone or bone particles, biocompatible synthetic materials, combinations thereof, etc, and may be designed for either animal or human use. Specifically, the osteoimplant suitable for use according to the disclosure herein will be any osteoimplant without limitation to the particular material(s) the osteoimplant is made of or the size or shape of the cavity.

The term "biocompatible" and expressions of like import shall be understood to mean the absence of stimulation of an undesired biological response to an implant and is distinguished from a mild, transient inflammation and/or granulation response which can accompany implantation of most foreign objects into a living organism and is also associated with the normal healing response. Materials useful to the invention herein shall be biocompatible if, at the time of implantation, they are present in a sufficiently small concentration such that the above-defined condition is achieved.

The term "particle" as utilized herein is intended to include bone pieces of all shapes, sizes, thickness and configuration such as fibers, threads, narrow strips, thin sheets, chips, shards, powders, etc., that possess regular, irregular or random geometries. It should be understood that some variation in dimension will occur in the production of the particles of this invention and particles demonstrating such variability in dimensions are within the scope in this invention. Particles useful herein can be homogenous, heterogeneous, and can include mixtures of human, xenogenic and/or transgenic material.

The term "human" as utilized herein in reference to suitable sources of implantable

materials refers to autograft bone which is taken from at least one site in implanted in another site of the grafter as well as allograft bone which is bone taken from a donor other than the grafter.

The term "autograft" as utilized herein refers to tissue that is extracted from the intended recipient of the implant.

The term "allograft" as utilized herein refers to tissue intended for implantation that is taken from a different member of the same species as the intended recipient.

The term "xenogenic" as utilized herein refers to material intended for implantation obtained from a donor source of a different species than the intended recipient. For example, when the implant is intended for use in an animal such as a horse (equine), xenogenic tissue of, e.g., bovine, porcine, caprine, etc., origin may be suitable.

The term "transgenic" as utilized herein refers to tissue intended for implantation that is obtained from an organism that has been genetically modified to contain within its genome certain genetic sequences obtained from the genome of a different species. The different species is usually the same species as the intended implant recipient but such limitation is merely included by way of example and is not intended to limit the disclosure here in anyway whatsoever.

The expressions "whole bone" and "substantially fully mineralized bone" refer to bone containing its full or substantially full, original mineral content.

The expression "demineralized bone" includes bone that has been partially, fully, segmentally or superficially (surface) demineralized.

The expression "substantially fully demineralized bone" as utilized herein refers to bone containing less than about 8% of its original mineral content.

The term "osteogenic" as applied to the bone plug and/or elongate bone particle composition thereof shall be understood as referring to the ability of an osteoimplant to

facilitate or accelerate the growth of new bone tissue by one or more mechanisms of osteogenesis, osteoconduction and/or osteoinduction.

The term "osteoinduction" shall be understood to refer to the mechanism by which a substance recruits cells from the host that have the potential for forming new bone and repairing bone tissue. Most osteoinductive materials can stimulate the formation of ectopic bone in soft tissue.

The term "osteoconduction" shall be understood to refer to the mechanism by which a non-osteoinductive substance serves as a suitable template or substrate along which bone may grow.

The term "osteogenesis" shall be understood to refer to cell-mediated bone formation.

The term "device" as utilized herein is intended to refer to any osteoimplant that is manufactured predominately of non-bone materials. Such devices are typically made of those materials commonly used in the manufacture of biocompatible implants, e.g., biocompatible metals such as surgical Bioglass[®], biocompatible polymeric materials, e.g., polylactic acid, polytetrafluoroethylene, etc., or any other suitable biocompatible non-bone material.

The term "shaped" as applied to the aggregate of elongate bone particles herein refers to a determined or regular form or configuration in contrast to an indeterminate or vague form or configuration (as in the case of a lump or other solid matrix of no special form) and is characteristic of such materials as sheets, plates, disks, cones, pins, screws, tubes, teeth, bones, portion of bone, wedges, cylinders, threaded cylinders, and the like, as well as more complex geometric configurations.

The term "coherent" as applied to the aggregate of elongate bone particles refers to the ability of the bone particles to adhere to each other either, e.g., by entanglement, or by the use of a biocompatible binder or adhesive.

The expression "three-dimensional" refers to the ability of the col
elongate bone particles to assume any desired shape and size.

The expression "open pore structure" as it applies to the coherent aggregate of
elongate bone particles constituting one embodiment of osteoimplant herein shall be
5 understood as referring to the low density, absorbent, sponge-like nature of the osteoimplant
in which there are a plurality of accessible pores or openings which are present throughout
the entire volume of the aggregate.

The term "incorporation" utilized herein refers to the biological mechanism whereby
host tissue gradually replaces the osteoimplant of the invention with native host bone tissue.
10 This phenomenon is also known in the scientific literature as "bone remodeling" or "cellular
based remodeling" and "wound healing response". Therefore, the term "incorporation"
utilized herein shall be understood as embracing what is conveyed to those skilled in the art
by the foregoing expressions.

The expression "further treatment" as utilized herein refers to procedures such as, e.g.,
15 lyophilizing, cross-linking treatment, re-mineralization, sterilization, etc., performed either
before, during or after the step of making the osteoimplant as well as post-processing
procedures such as, e.g., machining, laser etching, welding, assembling of parts, cutting,
milling, reactive etching, etc.

Another particularly useful embodiment of the invention herein is an osteoimplant
20 provided as a coherent aggregate, or matrix, of elongate bone particles possessing an open
pore structure and a low bulk density. The open pore structure of the aggregate renders the
osteoimplant highly absorbent of surrounding liquids. The osteoimplant formed from the
aggregate is flexible when dry (e.g., when containing less than about 6 weight percent water)
and does not require time-consuming rehydration prior to implantation. It can assume any
25 desired shape and/or configuration and can be cut to the desired dimensions, e.g., with

surgical scissors, before and/or after the aggregate has absorbed fluid. E
wetted/hydrated state, the osteoimplant will maintain its original shape and coherency and
can be readily handled by the medical practitioner.

Osteoinductivity can be conveniently quantified as the amount of bone formed in an
5 ectopic site in an athymic nude rat. Scores are rated 0 to 4. The osteoimplants of the
invention exhibit osteoinductivities of at least about 2, typically at least about 3, when
measured in an athymic rat assay as described in Edwards JT, Diegmann MH, Scarborough
NL, Osteoinduction of Human Demineralized Bone: Characterization in an Animal Model,
Clin. Orthop. Rel. Res. 357:219 228 (1998).

10 The osteoimplant of the invention can be combined with a wide variety of
biocompatible substances which can be introduced into the porous matrix of the osteoimplant
and/or into large cavities, depressions, and the like, produced in the osteoimplant. Thus, the
implant herein functions as a highly effective carrier and/or delivery vehicle for bone-growth
inducing and/or otherwise medically useful substances.

15 Further provided is a method of fabricating the osteoimplant herein which comprises
providing a quantity of elongate demineralized bone particles, mixing the elongate
demineralized bone particles with an aqueous wetting agent to provide a fluid composition
preferably containing from about 5 to about 40 volume percent swollen, hydrated bone
particles, placing the liquid composition in a mold, and removing a sufficient amount of
20 aqueous wetting agent, e.g., by heating the fluid composition in the substantial absence of
pressure at elevated temperature, to provide an osteoimplant comprising a shaped, coherent
aggregate, or matrix, of elongate bone particles, preferably one of open pore structure and
possessing a low bulk density, e.g., of less than about 3.0 g/cm^3 , preferably less than about
 2.5 g/cm^3 and more preferably less than about 1.5 g/cm^3 .

25 Further provided in accordance with the invention is a method of repairing and/or

treating bone including implanting at a bone repair site an osteoimplant shaped and dimensioned coherent aggregate of elongate bone particles, preferably one of open pore structure and possessing a low bulk density, e.g., on the order of less than about 3.0 g/cm^3 , preferably less than about 2.5 g/cm^3 and more preferably less than about 1.5 g/cm^3 .

The osteoimplant of the invention can be readily applied to virtually any bone repair site in the body and can be utilized alone or in combination with one or more adjunct medical devices and/or procedures. The osteoimplant of the invention finds particular utility in the areas of dental reconstructive surgery and spinal fusion where substantial amounts of body fluid, e.g., saliva and/or blood, are frequently encountered or where autograft (e.g., local bone, marrow or iliac crest, etc.) is incorporated in the osteoimplant. The unique ability of the osteoimplant to absorb body fluids and still retain its original shape represents a significant advance in the medical field. Additionally, the absorbent nature of the bioimplant encourages the wicking up and recruitment of cells which are essential to osteogenesis.

In one aspect the present invention provides an osteoimplant including a coherent aggregate of entangled elongate bone particles mixed with a biocompatible fluid carrier, the osteoimplant being flexible and further being formed as a strip at least one end of which possesses a tab for facilitating combination with another implant.

In another aspect the present invention provides a method of manufacturing a trough-shaped osteoimplant which includes:

- a) providing a quantity of elongate bone particles;
- b) combining the elongate bone particles with an aqueous medium to provide a moldable composition containing swollen, hydrated elongate bone particles;
- c) introducing the moldable composition into a cassette;
- d) impressing upon the exposed surface of the moldable composition a molding surface configured to form one or more depressions within said surface, the molding surface being fabricated from a material which lacks any appreciable adherency for the moldable composition; and,

e) removing aqueous medium from the molded composition to provide a molded osteoimplant including entangled elongate bone particles.

BRIEF DESCRIPTION OF THE SEVERAL VIEWS OF THE DRAWINGS

FIG. 1 illustrates an osteoimplant of this invention in the form of a strip especially adapted for use in a spinal fusion procedure such as scoliosis;

FIGS. 2 and 3 illustrate various combinations of the strips of Fig. 1;

FIG. 4 illustrates a trough-shaped osteoimplant manufactured by the method of the invention; and,

FIGS. 5-7 illustrate a molding surface, perforated cassette and lid that can be used in manufacturing the trough-shaped osteoimplant of Fig. 4.

DESCRIPTION OF THE PREFERRED EMBODIMENTS

The composition of the osteoimplant herein can be made up of from about 5 to about 100 weight percent fully demineralized and/or demineralized elongate bone particles. At least about 50 weight percent, preferably at least about 60 weight percent, and more

preferably at least about 90 weight percent of the bone particles present i
herein are of the elongate variety. Any non-elongate bone particles that are optionally
included in the osteoimplant can possess a wide range of dimensions, e.g., powders, chips,
etc. The elongate bone particles form a coherent aggregate, or matrix, which imparts porosity
5 and absorbency to the osteoimplant.

The bone component of the osteoimplant can be obtained from cortical, cancellous,
and/or corticocancellous allogenic, xenogenic or transgenic bone tissue. In general, allogenic
bone tissue is preferred as the source of the bone component. The bone component can be
fully mineralized or partially or fully demineralized. Porcine and bovine bones are
10 particularly advantageous types of xenogenic bone tissue that can be used individually or in
combination as sources for the bone particles although of course other xenogenic or
transgenic bone tissues can also be used. Combinations of fully mineralized and
demineralized bone can also be used.

The bone particles employed in the fabrication of the osteoimplant of this invention
15 are generally characterized as "elongate", i.e., they possess relatively high median length to
median thickness ratios. In overall appearance, the elongate bone particles can be described
as filaments, fibers, threads, slender or narrow strips, etc. Thus, e.g., the elongate bone
particles can possess a median length of from about 0.05 to about 400 mm, preferably from
about 1 to about 100 mm, a median width of from about 0.05 to about 2 mm, preferably from
20 about 0.08 to about 1.5 mm, and a ratio of median length to median width of from about 10:1
to about 2000:1, preferably of from about 20:1 to about 600:1. If desired, the elongate bone
particles can be graded into different sizes to reduce or eliminate any less desirable size(s) of
particles that may be present.

The elongate bone particles can be readily obtained by any one of several methods,
25 e.g., by milling or shaving the surface of an entire bone or relatively large section of bone.

Employing a milling technique, one can obtain a mass of elongate bone particles at least about 20 weight percent of bone particles coming within at least one of the aforesaid ranges of dimensions.

Another procedure for obtaining the elongate bone particles herein, particularly useful for pieces or sections of bone of up to about 100 mm in length, is the bone-processing mill described in commonly assigned U.S. Patent No. 5,607,269. Use of this bone mill results in the production of long, thin strips which quickly curl lengthwise to provide tubular-like elongate bone particles. These elongate bone particles may then optionally be ground, fractured, shredded or fragmented to yield smaller particles. This may be achieved using a grating device, a mortar and pestle or other conventional procedures for shredding and grating materials. The elongate bone particles and or shredded fragments are optionally subjected to demineralization in accordance with known and conventional procedures in order to reduce their inorganic mineral content. Such demineralization can occur prior to or after forming the elongate particles. Demineralization methods remove the inorganic mineral component of bone by employing acid solutions. Such methods are well known in the art, see for example, Reddi et al., *Proc. Nat. Acad. Sci.* 69, pp1601-1605 (1972), incorporated herein by reference. The strength of the acid solution, the shape of the bone particles and the duration of the demineralization treatment will determine the extent of demineralization. Reference in this regard may be made to Lewandrowski et al., *J. Biomed Materials Res*, 31, pp. 365-372 (1996), also incorporated herein by reference.

As used herein, the expression "superficially demineralized" refers to bone particles which have undergone surface demineralization as a result of which they possess one or more regions of surface-exposed collagen. The expression "partially demineralized bone" refers to bone possessing less than its original mineral content but not less than about 8 weight percent of its original mineral content. As previously stated, "substantially fully demineralized bone"

refers to bone containing less than about 8 weight percent, and usually less than about 1 weight percent, of its original mineral content. Mixtures of one or more of the foregoing types of demineralized bone particles can be employed. Moreover, one or more of the foregoing types of demineralized bone particles can be employed in combination with
5 nondemineralized bone particles, i.e., bone particles that have not been subjected to demineralization. It will be understood by those skilled in the art that fully demineralized bone particles yield a more porous mass compared to whole bone or superficially demineralized bone particles.

When prepared in whole or in part from bone particles that are only superficially
10 demineralized or nondemineralized, the osteoimplant will tend to possess a fairly high compression strength, e.g., one approaching that of natural bone. Accordingly, when an osteoimplant exhibiting rigidity, e.g., a compression strength of on the order of from about 5 to about 200 MPa, preferably from about 20 to about 100 MPa and more preferably from about 25 to about 75 MPa, is desired, superficially demineralized bone particles and/or
15 nondemineralized bone particles are advantageously employed.

In a preferred demineralization procedure, relatively large mineralized bone piece(s) from which demineralized bone particles are subsequently obtained, or fully mineralized bone particles obtained from such relatively large mineralized bone piece(s), are subjected to a defatting/disinfecting step, which is followed by an acid demineralization step. A preferred
20 defatting/disinfectant solution is an aqueous solution of ethanol, the ethanol being a good solvent for lipids and the water being a good hydrophilic carrier to enable the solution to penetrate more deeply into the bone particles. The aqueous ethanol solution also disinfects the bone by killing microorganisms and viruses. Ordinarily, at least about 10 to about 40 percent by weight of water (i.e., about 60 to about 90 weight percent of defatting agent such
25 as alcohol) should be present in the defatting disinfecting solution to produce optimal lipid

removal and disinfecting within the shortest period of time. The preferred range of the defatting solution is from about 60 to about 85 weight percent alcohol and most preferably about 70 weight percent alcohol. Following defatting, the bone particles are immersed in acid over time to effect their demineralization. Acids which can be employed in this step include inorganic acids such as hydrochloric acid and organic acids such as peracetic acid. After acid treatment, the demineralized bone particles are rinsed with sterile water for injection to remove residual amounts of acid and thereby raise the pH. The elongate bone particles used in the manufacture of the plug naturally entangled or may be mechanically entangled employing, e.g., the wet laying procedure, akin to a paper-making process, described in aforementioned U.S. Patent No. 5,507,813 to Dowd et al., to provide a sheet-like coherent mass of bone particles which can thereafter be shaped, e.g., by cutting, molding, etc., before or after drying and/or other processing into configurations corresponding to those desired for the bone plug of this invention.

If desired, the bone particles before or after their being gathered into a coherent aggregate can be modified in one or more ways, e.g., their protein content can be augmented or modified as described in U.S. Patent Nos. 4,743,259 and 4,902,296, the contents of which are incorporated by reference herein. The elongate bone particles can also be admixed with one or more substances such as binders/fillers, plasticizers, biostatic/biocidal agents, surface active agents, drugs, DNA vectors and the like, prior to, during, or after shaping the elongate bone particles into a desired configuration and size. One or more of such substances can be combined with the bone particles by soaking or immersing the elongate bone particles in a solution or dispersion of the desired substance, by physically admixing the elongate bone particles and the desired substance, co-extrusion of the substance and particles, and the like.

Suitable binders/fillers include cyanoacrylates, epoxy-based compounds, dental resin sealants, dental resin cements, calcium phosphate and calcium sulfate self-setting cements,

glass ionomer cements, polymethyl methacrylate, gelatin-resorcinol-form
protein and collagen-based glues, acrylic resins, cellulose, bioabsorbable polymers such as
polyglycolide, polylactide, glycolide-lactide copolymers, polycaprolactone, polyanhydrides,
polycarbonates, polyorthoesters, polyamino acids, polyarylates, polycyanoacrylates,
5 polyhydroxybutyrate, polyhydroxyvalyrate, polyphosphazenes, and polyvinylpyrrolidone,
carbohydrate polymers, polyiminocarbonates, polypropylene fumarates, polyanhydride esters,
polytetrafluoroethylene, hexacryl, Hyaluronic acid, fibrin, fibrin-collagen, polyethylene
glycol glues, mucopolysaccharides, mussel adhesive proteins, fatty acids and fatty acid
derivatives, etc.

10 Other suitable binders/fillers include bone powder, demineralized bone powder, porous
calcium phosphate ceramics, hydroxyapatite, tricalcium phosphate, Bioglass[®] and other
calcium phosphate materials, calcium sulfate or calcium carbonate particles, etc.

Suitable plasticizers include liquid polyhydroxy compounds such as glycerol,
monoacetin, diacetin, hydrogels, etc.

15 Suitable biostatic/biocidal agents include antibiotics, povidone, sugars,
mucopolysaccharides, etc.

Suitable surface-active agents include the biocompatible nonionic, cationic, anionic
and amphoteric surfactants. It will be understood by those skilled in the art that the foregoing
list is not intended to be exhaustive and that other materials may be admixed with bone
20 particles within the practice of the disclosure herein such as disclosed in U.S. Patent No.
5,073,373, the contents of which are incorporated by reference herein.

Any of a variety of bioactive substances can be incorporated in, or associated with,
the bone particles before, during or after fabrication of the osteoimplant. Thus, one or more
of such substances can be combined with the elongate bone particles by soaking or
25 immersing them in a solution or dispersion of the desired substance(s). Bioactive substances

include physiologically or pharmacologically active substances that act locally or systemically in the host.

Representative classes of bioactive factors which can be readily combined with the bone particles include, e.g., trophic factors, analgesics, anti-cancer agents, vaccines, adjuvants, antibodies, neuroleptics, genes and genetic elements for transfection including viral vectors for gene therapy, cells or cellular components, etc. A list of more specific examples would therefore include, collagen, insoluble collagen derivatives, etc., and soluble solids and/or liquids dissolved therein, e.g., antivirals, particularly those effective against HIV and hepatitis; antimicrobials and/or antibiotics such as erythromycin, bacitracin, neomycin, penicillin, polymyxin B, tetracyclines, biotycin, chloramphenicol, and streptomycins, cephalosporins, ampicillin, azactam, tobramycin, clindamycin and gentamicin, etc.; biocidal/biostatic sugars such as dextran, glucose, etc.; amino acids, peptides, vitamins, inorganic elements, co-factors for protein synthesis; hormones; endocrine tissue or tissue fragments, synthesizers; enzymes such as collagenase, peptidases, oxidases, etc., polymer cell scaffolds with parenchymal cells, angiogenic drugs and polymeric carriers containing such drugs; collagen lattices; antigenic agents; cytoskeletal agents; cartilage fragments, modified living cells such as chondrocytes, bone marrow cells, mesenchymal stem cells, natural extracts, genetically engineered living cells or otherwise modified living cells, DNA delivered by plasmid or viral vectors, genes or genetic elements, tissue transplants, demineralized bone powder, autogenous tissues such as blood, serum, soft tissue, bone marrow, etc.; bioadhesives; non-collagenous proteins such as osteopontin, osteonectin, bone sialoprotein, laminin, fibrinogen, vitronectin, thrombospondin, proteoglycans, decorin, beta glycan, biglycan, aggrecan, versican, tenascin, matrix gla protein, hyaluronan, amino acids, amino acid residues, peptides, bone morphogenic proteins (BMPs); osteoinductive factor (OIF); fibronectin (FN); endothelial cell growth factor (ECGF); cementum attachment

extracts (CAE); ketanserin; human growth hormone (HGH); animal growth factor (EGF); interleukin-1 (IL-1); human alpha thrombin; transforming growth factor (TGF-beta); insulin-like growth factor (IGF-1) (IGF-2); platelet derived growth factors (PDGF); fibroblast growth factors (FGF, aFGF, bFGF, etc.); periodontal ligament chemotactic factor (PDLGF); somatotropin; bone digestors; antitumor agents; immunosuppressants; fatty acids (including polar and non-polar fatty acids); permeation enhancers, e.g., fatty acid esters such as laurate, myristate and stearate monoesters of polyethylene glycol, enamine derivatives, alpha-keto-aldehydes, etc.; and nucleic acids; inorganic elements, inorganic compounds, cofactors for protein synthesis, hormones, soluble and insoluble components of the immune system; soluble and insoluble receptors including truncated forms; soluble, insoluble and cell surface bound ligands including truncated forms; chemokines, bioactive compounds that are endocytosed; endocrine tissue or tissue fragments, growth factor binding proteins, e.g., insulin-like growth factor binding protein (IGFBP-2) (IGFBP-4) (IGFBP-5) (IGFBP-6); angiogenic agents, bone promoters, cytokines, interleukins, genetic material, genes encoding bone promoting actions, cells containing genes encoding bone promoting action; growth hormones such as somatotrophin; bone digestors; antitumor agents; cellular attractants and attachment agents; immunosuppressants; bone resorption inhibitors and stimulators; angiogenic and mitogenic factors; bioactive factors that inhibit and stimulate secondary messenger molecules; cell adhesion molecules, e.g., cell-matrix and cell-cell adhesion molecules; secondary messengers, monoclonal antibodies specific to cell surface determinants on mesenchymal stem cells, clotting factors; externally expanded autograft or xenograft cells, nucleic acids and any combination thereof. The amounts and types of such optionally added substances can vary widely with optimum levels and combinations being readily determined in a specific case by routine experimentation.

25 Various shapes of osteoimplant can be made by using extrusion or injection molding

techniques, compression molds, pre-formed molds in which the material obtain its final shape, or pre-formed shapes which can be used to cut desired shape from pre-formed material. Further to this, devices can be used that allow introduction of various agents in to the molding devices or treatments of the molds to assist in the forming of various shapes, such as, but not limited to, cross linking agents or heat or cooling of the molds and/or during the forming process. Employing such procedures, various sizes and shapes of osteoimplant can be provided such as those illustrated in Figs. 1 a-h.

In one embodiment herein, an osteoimplant as previously described is made by forming demineralized elongate bone particles into a coherent aggregate and thereafter either cutting the osteoimplant from the aggregate or, preferably, to reduce waste, molding the aggregate into an osteoimplant of the desired size and configuration. To fabricate the coherent mass of elongate bone particles, a quantity of elongate bone particles with or without one or more optional materials is mixed with a suitable biocompatible fluid component, e.g., water, organic protein solvent, physiological saline, concentrated saline solution, ionic solution of any kind, aqueous sugar solution, liquid polyhydroxy compound such as glycerol or glycerol ester, hydrogel, etc., or mixtures thereof. The suitable biocompatible fluid can optionally contain one or more substances such as binder, filler, plasticizer, biostatic/biocidal agent, surface active agent, bioactive substance, etc., as previously described to form a slurry or paste. Excess fluid is then removed from the slurry or paste, e.g., by applying the slurry or paste to a mesh or screen and draining away excess fluid. Functionally, the biocompatible fluid provides a coherent aggregate of elongate bone particles whose consistency can be described as shape-sustaining but readily deformable, e.g., putty-like.

If desired, the elongate bone particles can be dried, e.g., at from about 30° to about 80°C and preferably from about 40° to about 50°C, for from about 1 to about 3 hours, and

then lyophilized under conditions that are well known in the art, e.g., at :
from about -20° to about -35°C, a vacuum of from about 150 to about 100 mTorr and for a
period of time ranging from about 4 to about 48 hours. The drying and lyophilization steps
will result in the production of a coherent mass of entangled elongate bone particles that is
5 relatively strong when dry and flexible when wetted or hydrated.

In another embodiment of the general method described above, the coherent aggregate
of elongate bone particles can be subjected to a compressive force, e.g., of up to about
100,000 psi, during and/or after the step of removing excess liquid and/or while the drained-
but-still-wet bone particles are being dried. If desired, the compressed coherent mass can be
10 lyophilized to provide an especially strong and rigid mass.

In yet a further embodiment disclosed herein, the elongate bone particles, in
combination with bone particles possessing other geometries such as mineralized and
demineralized bone powders and pieces, can be combined with a wetting agent as described
above to produce a flowable composition containing from about 5 to about 100%, preferably
15 from about 20 to about 60%, volume percent of bone particles of all types, the remainder of
the composition comprising wetting agent. The wetting agent can optionally comprise one or
more biocompatible components as previously described. The wetting agent will cause the
demineralized elongate bone particles to swell and increase in flexibility. The fluid
composition will possess a consistency ranging from a slurry or paste to a wet dough,
20 depending on the amount of wetting agent used. The critical aspect is that the elongate bone
particles be suspended in and evenly distributed throughout the fluid composition. This is to
be contrasted with the “wet laying” procedure of U.S. Patent No. 5,507,813 in which wetting
agent is substantially removed to produce a dense mat of bone particles.

In this embodiment, the fluid composition is formed by mixing the bone particles and
25 wetting agent to form a liquid slurry, stirring the slurry for a suitable period of time sufficient

to allow the wetting agent to penetrate the demineralized elongate bone particles. Removing enough wetting agent, e.g., by draining through a sieve, sufficient to provide a fluid composition containing from about 5 to about 25, preferably from about 10 to about 15, volume percent bone particles. Substantial mechanical entanglement of the elongate bone particles will occur. Suitable wetting agents include biocompatible liquids and/or hydrogels such as previously described. Optionally, the wetting agent can comprise dissolved or admixed therein one or more biocompatible substances such as previously described.

Preferred wetting agents for forming the wetted mass of bone particles include water, liquid polyhydroxy compounds and their esters, and polyhydroxy compounds in combination with water and/or surface-active agents. Specific polyhydroxy compounds of the foregoing type include glycerol and its monoesters and diesters derived from low molecular weight carboxylic acids, e.g., monoacetin and diacetin (respectively, glycerol monoacetate and glycerol diacetate), ethylene glycol, diethylene glycol, triethylene glycol, 1,2-propanediol, trimethylolethane, trimethylolpropane, pentaerythritol, sorbitol, polyethylene glycol, polyoxyalkylenes, e.g., Pluronic[®], and the like. The preferred polyhydroxy compounds possess up to about 12 carbon atoms and, where their esters are concerned, are preferably the monoesters and diesters. Of these, glycerol is especially preferred as it improves the handling characteristics of the bone particles wetted therewith and is biocompatible and easily metabolized. Most preferred are solutions of polyhydroxy compounds in water, with glycerol/water solutions in weight ratios ranging from about 40:60 to about 5:95, respectively, being especially preferred. Mixtures of polyhydroxy compounds or esters, e.g., sorbitol dissolved in glycerol, glycerol combined with monoacetin and/or diacetin, etc., are also useful.

Where the bone particles have a tendency to quickly or prematurely separate or to otherwise settle out from the fluid composition such that formation of a homogeneous

suspension of bone particles in wetting agent is rendered difficult, it can include within the composition a suspension aid. Thus, e.g., where the wetting agent is water and/or glycerol and separation of bone particles occurs to an excessive extent where a particular application is concerned, a thickener such as a solution of polyvinyl alcohol, polyvinylpyrrolidone, cellulosic ester such as hydroxypropyl methylcellulose, carboxy methylcellulose, pectin, xanthan gum, food-grade texturizing agent, gelatin, dextran, collagen, starch, hydrolyzed polyacrylonitrile, hydrolyzed polyacrylamide, polyelectrolyte such as polyacrylic acid salt, hydrogels, chitosan, other materials that can suspend particles, etc., can be combined with the wetting agent in an amount sufficient to significantly improve the suspension-keeping characteristics of the composition. Furthermore, suspension aids that generate gas bubbles inside the fluid composition can be employed. The gas bubbles reduce the tendency of the bone particles to settle out and include peroxides and bicarbonate.

As stated previously, the fluid composition is preferably placed in a mold which optionally is configured and dimensioned at least partially in the shape of the final osteoimplant. Care must be taken to ensure that minimal, if any, pressure is applied to the composition in the mold which would effect compaction of the elongate bone particles. This is in contrast to the wet-lay procedure described in U.S. Patent No. 5,507,813. The composition is then dried at a temperature of from about 30°C to about 80°C, preferably from about 30°C to about 40°C to effect removal of water and provide a shaped material. Following the drying step, the shaped material is dried e.g., freeze-dried, employing a shelf temperature of from about -20° to about -35°C and a vacuum of from about 150 to about 100 mTorr applied for from about 4 to about 48 hours. The resulting shaped material is porous and absorbent and maintains its shape and cohesiveness upon absorption of fluid. The implant can be easily cut with scissors or other cutting tools in either the dry or rehydrated state.

Alternatively, a slurry of demineralized elongate bone particles c
porous tube. The bone particles can be dried and lyophilized in the tube, then removed and
cut to length. Examples of suitable porous tubes are dialysis tubing, sausage casings, and
rigid metal or plastic tubing perforated with a series of small holes (the holes generally being
5 small enough that a few fibers escape, preferably 0.2mm or less). It is also possible to use
rigid tubing with large holes, and line with another tube that will contain the bone particle
slurry such as a flexible dialysis tube. The slurry can be injected into the tube by any suitable
means, for example a disposable plastic syringe or a slurry pump. If a thin, flexible tube is
used to form the osteoimplant, the osteoimplant can be cut to length (after drying) while
10 inside the tube by cutting through both the tube and the material inside. Alternatively, the
dried aggregate elongate bone particles can be removed from the flexible tube (preferably by
cutting the tube away) or from a rigid tube (preferably by pushing the material out of the
tube) and then cut. Cutting is facilitated by using a cutting jig or guide similar to a cigar
cutter or a small double bladed guillotine type of device where the blade spacing equals the
15 desired plug length. Osteoimplants that are dried in a porous tube can have a tougher skin on
their outer circumferential surface due to more rapid water loss from the surface than the
interior. This can be advantageous in that the osteoimplant will resist insertion and handling
forces better. The thickness and toughness of the skin can be influenced by a combination of
drying conditions and tubing porosity.

20 Optionally, the exposed collagen on the surfaces of mutually contacting bone particles
in the osteoimplant can be chemically linked to each other employing techniques such as
those disclosed in U.S. Patent No. 6,294,187, a copy of which is included herewith and is to
be regarded as an integral part of this provisional application. These crosslinking procedures
result in the formation of chemical bonds between the surface-exposed collagen of mutually
25 contacting surface-demineralized and/or substantially completely demineralized elongate

bone particles making up, or contained in, the aggregate of naturally or n
entangled elongate bone particles.

Where a mold is employed to shape the coherent mass of bone particles into the
osteoinplant of this invention, the walls of the mold can be coated with a slurry or paste
5 containing partially and/or fully demineralized bone particles followed by addition of a slurry
or paste containing non-demineralized and/or superficially demineralized bone particles (or
vice versa). The resulting molded osteoinplant contains at least one region, e.g., an outer
surface, composed of partially and/or fully demineralized bone particles and at least one
region, e.g., a core, composed of non-demineralized and/or superficially demineralized bone
10 particles. In this manner, the differential in compressive strength, porosity, osteogenicity and
other properties between partially and/or fully demineralized bone particles on the one hand
and non-demineralized and/or superficially demineralized bone particles on the other hand
can be exploited. For example, where the osteoinplant is employed in a load-bearing
situation, non-demineralized and/or superficially demineralized bone particles can be
15 concentrated in that region of the osteoinplant which will be subjected to an applied load at
the implant site.

The osteoinplants of the invention can vary widely in density, e.g., from about 0.1
 g/cm^3 to about 10g/cm^3 . Low densities, e.g., those not exceeding about 3.0g/cm^3 , are
preferred. More preferred are densities of from about 0.5 to about 2.0g/cm^3 and most
20 preferred are those of from about 0.8 to about 1.2g/cm^3 .

The density (and void volume) of the osteoinplant can be controlled by the amount
(usually described in grams) of bone fibers which are molded within a given mold volume.
Practically speaking, using additional fibers to produce a higher density osteoinplant within a
specified volume mold, will require the application of more pressure. In addition, if excess
25 liquid is not removed prior to pressurization, the extrusion of more liquid must be

accommodated when molding at higher pressures. One preferred embodiment invention features a fixed rectangular mold (mold body) fitted with a cover (mold lid) having a closely fitting lid with a protruding surface extending into the mold. When the mold lid is applied, the protruding surface inserts into the mold body and serves as the upper interior surface of the mold. With the lid in place the interior volume of the mold is defined. (and the ultimate volume of the bioimplant). The height of the mold body will be designed to accommodate the required volume of demineralized bone fibers to be molded. The depth of the protruding surface of the lid is designed to produce the desired interior volume after application and pressurization. Alternately, ridges or other protrusions may be placed in the mold body to create tabs, lips, flanges or other reverse shapes in the final bioimplant.

A specific density osteoimplant is then prepared as follows: following demineralization, the elongated bone particles are suspended in slurry form with aqueous medium. A sample of the slurry is vacuum filtered to remove free residual liquid, and then lyophilized. The weight of wet slurry giving rise to the lyophilized weight is then determined. This conversion is used to determine the wet weight of bone particles required to produce the desired density osteoimplant in the given mold volume. The appropriate amount of bone particles are placed in the mold body and a gentle vacuum is applied to remove residual free solution. The lid is then applied and pressurized molding is performed in the presence of the appropriate amount of heat for the designated amount of time. Following demolding the osteoimplant is lyophilized.

Typically, the lyophilized osteoimplant of this invention, including its putty-like moldable forms, will possess a residual moisture (water) content of from about 0.6 to about 6.0 weight percent. This residual moisture, in combination with other non-volatile biocompatible materials, such as liquids, permits the lyophilized osteoimplant such as the strip of Fig. 1 to form the constructs or combinations shown in Figs. 2 and 3 by slight

pressure, e.g., finger pressure applied to the superimposed tabs.

The foregoing description and embodiments were chosen and described to best explain the principles of the invention and its practical applications, thereby enabling others skilled in the art to best utilize the invention in its various embodiments and with various
5 modifications as are suited to the particular use contemplated. Therefore, the foregoing descriptions of the preferred embodiments of the disclosure herein have been presented for purposes of illustration and description and are not intended to be exhaustive or to limit the invention to the precise forms disclosed. Obviously, many other modifications and variations are possible in light of the above teachings.

10 The following examples illustrate the practice of the present invention and in no way limit the scope of the claims appended hereto.

EXAMPLE 1

This example illustrates the preparation of an osteoimplant of the invention in the form of the generally rectangular strip shown in Fig. 1. Osteoimplant 10 possesses a tab 11
15 of step-like configuration which facilitates combining like strips as shown in Figs. 2 and 3. Tab 11 includes a first face 12, a flat surface 13 and a second face 14. In general, the osteoimplant can possess a length (inclusive of tab 11) of from about 2 cm to about 50 cm and preferably from about 5 cm to about 20 cm, a width of from about 0.2 cm to about 5 cm, and preferably from about 0.5 cm to about 3 cm, and a depth of from about 0.2 cm to about
20 2.0 cm, and preferably from about 0.5cm to about 1.0cm, with a ratio of length to width of from about 1 to about 5, preferably from about 1 to about 10 and most preferably from about 1 to about 20. Specific dimensions of osteoimplant 10 are a length (inclusive of tab 11) of 10 cm or 20 cm, a width of 1.0 cm, a height of 0.8 cm, a height of 0.4 cm for each of faces 12 and 14 and a length of 1.5 cm for flat surface 13.

25 Osteoimplant 10 is initially formed as a single sheet with a predetermined thicknesses, e.g., of about 0.4 cm to about 1.2 cm which, following lyophilization, is cut into strips of the

desired configuration and dimensions. The sheet is prepared by uniform about 250 g to about 350 g of elongate demineralized bone particles with from about 250 ml to about 1750 ml of glycerol and from about 250 ml to about 3500 ml of distilled deionized water to provide a slurry. The volume of glycerol added per 1 gram of bone particle may vary from about 1 ml to about 5 ml of glycerol per gram of bone. The volume of water added per 1 gram of bone particles may vary from about 1 ml to about 10 ml per gram of bone. The elongate bone particles possess a median length of about 1 to about 100 mm, a median width of about 0.08 to about 1.5 mm and a ratio of median length to median width of about 20:1 to about 600:1. The slurry is then introduced into a rectangular cassette (mold) possessing two raised ridges on one or two sides so as to provide the tab feature following the cutting of the resulting sheet into strips. The raised ridge(s) can be from about 0.2 cm to about 1.0 cm, preferably 0.3 cm to about 0.6 cm in height and from about 0.2 cm to about 5.0 cm, preferably from about 0.5 cm to about 2.0 cm, in width. After a period of from about 1 to 8 hours to permit swelling and hydration of the bone particles, the sheet is lyophilized under conventional lyophilization conditions, cut into individual strips and aseptically packaged for storage and/or shipment. In one preferred embodiment the density of the strips based on their dimensions and weight is calculated to be about 0.952 g/cm^3 to about 0.966 g/cm^3 .

Because of their tab feature, several strips can be attached to, an interlocked with, each other as shown in Figs. 2 and 3 while maintaining the same depth dimension. The strips may be sutured together, glued, cemented, clipped, pinned, screwed or otherwise fastened to each other to form virtually any desired length. The length of the strip permits the surgeon to lay it close to the spinous processes of the spine and in the gutters of the spine in a long, continuous and cohesive manner. The strip can also be wrapped around any or all of the posterior elements to permit spinal fusion. This is advantageous because the instrumentation (metal bars, screws and hooks, etc.) attached to vertebrae during many spinal fusion

procedures are not osteoinductive or osteoconductive. The strip herein
osteogenicity, osteoinductivity and osteoconductivity to encourage fusion of the spinous
processes, superior articular processes, transverse processes, mamillary processes (essentially
all posterior elements of the spine), etc. The strip can be used in PostLateral Fusion
5 procedures in smaller patients or in any indication where distances between vertebrae are
smaller. Because of its dimensions, the strip can easily be implanted between screws or
hooks and the vertebral bodies to encourage spinal fusion.

EXAMPLE 2

This example illustrates the preparation of a putty-like, easily moldable osteoimplant
10 composition in accordance with the invention.

Approximately 200 g to about 300 g of the elongate bone particles used in making the
strip-configured osteoimplant of Example 1 are uniformly combined with from about 5 ml to
about 15 ml of glycerol per gram of elongate bone particles and from about 5 mls to about 20
ml of distilled deionized water per gram of elongate bone particles to form a slurry which is
15 permitted to swell and hydrate over a period of from 1 to 8 hours. Optionally, prior to either
the addition of glycerol, water or both, the elongate fibers may be grated or shredded to
reduce any one or more of their overall dimensions. A further optional treatment would be to
knead, blend, grind or shred the elongate fibers after the addition of glycerol, water or both.
Excess liquid is drained from the slurry and the mixture is thereafter lyophilized under
20 conventional lyophilization conditions. The resulting putty-like osteoimplant material is
aseptically packaged for storage and/or shipment.

EXAMPLE 3

This example illustrates the manufacture of the trough-like osteoimplant 20 shown in
Fig. 4. Osteoimplant 20 possesses a generically rectangular shape and features a trough-like
25 rectangular depression 21. A quantity of such osteoimplants can be conveniently formed

using form 30 shown in Fig. 5, cassette 40 shown in Fig. 6 and lid 50 sl

A slurry of swollen, hydrated demineralized elongated bone particles in glycerol and water prepared as described in Example 2 is introduced into cassette 40 of Fig. 6. The perforated base of the cassette permits excess liquid to drain from the slurry. A molding surface in the form of sheet 30 of Fig. 5 having little or no adherency for the slurry and possessing depressions 31 is then impressed upon the exposed surface of the slurry with the application of a gentle amount of pressure so as to provide a molded sheet of substantially uniform thickness (from about 0.5 cm to about 1.0 cm) possessing depressions conforming to the depressions in the molding surface. One suitable molding surface that can be used herein with generally good results is a thermoformed clear polypropylene sheet possessing the desired number, shape and size of depressions 31. With sheet 30 in place, lid 50 of Fig. 7 is placed on top of the cassette-sheet assembly. Lid 50 can be non-perforated or, if desired, perforated as shown.

The cassette-sheet-lid assembly containing molded, drained slurry is then heated at about 35 to about 50°C for about 4 to about 6 hours after which the molded material is lyophilized as in Example 1, lid 50 and sheet 30 are removed, the molded material is removed from the cassette and cut into individual trough-shaped implants 20 as shown in Fig. 4. The individual implants are then aseptically packaged for storage and/or shipment.

THE CLAIMS DEFINING THE INVENTION ARE AS FOLLOWS:

1. An osteoimplant including a coherent aggregate of entangled elongate bone particles mixed with a biocompatible fluid carrier, the osteoimplant being flexible and further being formed as a strip at least one end of which possesses a tab for facilitating combination with another implant.
5
2. The osteoimplant of Claim 1 in which the density of the strip is less than about 3g/cm^3 .
3. The osteoimplant of Claim 1 in which the density of the strip is less than about 1g/cm^3 .
- 10 4. The osteoimplant of Claim 1 in which the strip is of generally rectangular configuration having a length of from about 2 cm to about 50 cm, a width of from about 0.2 cm to about 5 cm and a depth of from about 0.2 to about 2 cm, the ratio of the length to the width being from about 1.0 to about 20.
- 15 5. The osteoimplant of Claim 4, in which the density of the strip is less than about 3g/cm^3 .
6. The osteoimplant of Claim 4 in which the density of the strip is less than about 1g/cm^3 .
- 20 7. The osteoimplant of Claim 1 in combination with at least one other such osteoimplant, a tab of one strip of osteoimplant being superimposed upon and in adherent contact with, the tab of another strip of osteoimplant.
8. The osteoimplant of Claim 1 wherein mutually contacting elongate bone particles are additionally bonded to each other.
9. The osteoimplant of Claim 1 wherein the elongate bone particles represent at least about 50 weight percent of the aggregate.

10. The osteoimplant of Claim 1 wherein the elongate bone particles represent at least about 60 weight percent of the aggregate.

11. The osteoimplant of Claim 1 wherein the elongate bone particles represent at least about 90 weight percent of the aggregate.

5 12. The osteoimplant of Claim 1 wherein the aggregate further includes non-elongate bone particles.

13. The osteoimplant of Claim 1 wherein the elongate bone particles are obtained from cortical, cancellous, corticocancellous allogenic, xenogenic or transgenic bone tissue.

10 14. The osteoimplant of Claim 1 wherein the elongate bone particles possess the capability to facilitate or accelerate new bone growth by at least one of osteogenesis, osteoconduction and osteoinduction.

15 15. The osteoimplant of Claim 1 wherein the median length of the elongate bone particles is from about 0.05 to about 400mm, the median width of the elongate bone particles is from about 0.05 to about 2mm and the ratio of median length to median width is from about 10:1 to about 2000:1.

20 16. The osteoimplant of Claim 1 wherein the median length of the elongate bone particles is from about 1 to about 100 mm, the median width of the elongate particles is from about 0.08 to about 1.5 mm and the ratio of median length to median width is from about 20:1 to about 600:1

17. The osteoimplant of Claim 1 wherein at least some of the elongate bone particles are substantially fully mineralized, substantially fully demineralized, partially demineralized or superficially demineralized.

25 18. The osteoimplant of Claim 12 wherein at least some of the non-elongate bone particles are substantially fully mineralized, substantially fully demineralized, partially demineralized or superficially demineralized.

19. The osteoimplant of Claim 1 wherein elongate bone particles are admixed with one or more of the group consisting of binders/fillers, plasticizers, biostatic/biocidal agents, bioactive substances, surface active agents prior to, during and/or after forming the aggregate into the osteoimplant.

5 20. The osteoimplant of Claim 19 wherein the binder/filler is selected from the group consisting of cyanoacrylates, epoxy-based compounds, dental resin sealants, dental resin cements, calcium phosphate and calcium sulfate self-setting cements, glass ionomer cements, polymethyl methacrylate, gelatin-resorcinol-formaldehyde glues, protein and collagen-based glues, acrylic resins,
10 cellulotics, bioabsorbable polymers such as polyglycolide, polylactide, glycolide-lactide copolymers, polycaprolactone, polyanhydrides, polycarbonates, polyorthoesters, polyamino acids, polyarylates, polycyanoacrylates, polyhydroxybutyrate, polyhydroxyvalyrate, polyphosphazenes, polyvinylpyrrolidone, polyarylates, tyrosine-based polycarbonates and
15 polyarylates, carbohydrate polymers, polyiminocarbonates, polypropylene fumarates, polyanhydride esters, polytetrafluoroethylene, hexacryl, Hyaluronic acid, fibrin, fibrin-collagen, polyethylene glycol glues, mucopolysaccharides and mussel adhesive proteins, fatty acids and fatty acid derivatives.

20 21. The osteoimplant of Claim 19 wherein the binder/filler is selected from the group consisting of bone powder, demineralized bone powder, porous calcium phosphate ceramics, hydroxyapatite, tricalcium phosphate, Bioglass[®] and other calcium phosphate materials, calcium sulfate or calcium carbonate particles.

22. The osteoimplant of Claim 19 wherein the plasticizer is selected from the group liquid polyhydroxy compound.

25 23. The osteoimplant of Claim 22 wherein the liquid polyhydroxy compound is glycerol.

24. The osteoimplant of Claim 19 wherein the biostatic/biocidal agent is selected from the group consisting of antibiotics, povidone, sugars and mucopolysaccharides.

25. The osteoimplant of Claim 19 wherein the surface-active agent is selected from the group consisting of biocompatible nonionic, cationic, anionic and amphoteric surfactant.

26. The osteoimplant of Claim 19 wherein the bioactive substance is selected
5 from the group consisting of trophic factors, analgesics, anti-cancer agents, vaccines, adjuvants, antibodies, neuroleptics, genes and genetic elements for transfection, cells or cellular components, collagen, insoluble collagen derivatives, and soluble solids and/or liquids dissolved therein, antiviricides, particularly those effective against HIV and hepatitis; antimicrobials and/or antibiotics such as
10 erythromycin, bacitracin, neomycin, penicillin, polymycin B, tetracyclines, biomyacin, Chloromycetin, and streptomycins, cephalosporins, ampicillin, azactam, tobramycin, clindamycin and gentamicin; biocidal/biostatic sugars such as dextran, glucose; amino acids, peptides, vitamins, inorganic elements, co-factors for protein synthesis; hormones; endocrine tissue or tissue fragments,
15 synthesizers; enzymes such as collagenase, peptidases, oxidases, polymer cell scaffolds with parenchymal cells, angiogenic drugs and polymeric carriers containing such drugs; collagen lattices; antigenic agents; cytoskeletal agents; cartilage fragments, modified living cells such as chondrocytes, bone marrow cells, mesenchymal stem cells, natural extracts, genetically engineered living
20 cells or otherwise modified living cells, DNA delivered by plasmid or viral vectors, genes or genetic elements, tissue transplants, demineralized bone powder, autogenous tissues, blood, serum, soft tissue, bone marrow, bioadhesives; non-collagenous proteins, osteopontin, osteonectin, bone sialo protein, laminin, fibrinogen, vitronectin, thrombospondin, proteoglycans, decorin, beta glycan,
25 biglycan, aggrecan, versican, tenascin, matrix gla protein, hyaluronan, amino acids, amino acid residues, peptides, bone morphogenic proteins (BMPs); osteoinductive factor (OIF); fibronectin (FN); endothelial cell growth factor (ECGF); cementum attachment extracts (CAE); ketanserin; human growth hormone (HGH); animal growth hormones; epidermal growth factor (EGF);
30 interleukin-1 (IL-1); human alpha thrombin; transforming growth factor (TGF-beta); insulin-like growth factor (IGF-I) (IGF-2); platelet derived growth factors (PDGF); fibroblast growth factors (FGF, aFGF, bFGF, etc.); periodontal ligament

chemotactic factor (PDLGF); somatotropin; bone digesters; antitumor agents; immuno-suppressants; fatty acids (including polar and non-polar fatty acids); permeation enhancers, fatty acid esters, laureate, myristate and stearate monoesters of polyethylene glycol, enamine derivatives, alpha-keto-aldehydes, and nucleic acids; inorganic elements, inorganic compounds, cofactors for protein synthesis, hormones, soluble and insoluble components of the immune system; soluble and insoluble receptors including truncated forms; soluble, insoluble and cell surface bound ligands including truncated forms; chemokines, bioactive compounds that are endocytosed; endocrine tissue or tissue fragments, growth factor binding proteins, insulin-like growth factor binding protein (IGFBP-2) (IGFBP-4) (IGFBP-5) (IGFBP-6); angiogenic agents, bone promoters, cytokines, interleukins, genetic material, genes encoding bone promoting actions, cells containing genes encoding bone promoting action; growth hormones such as somatotrophin; bone digesters; antitumor agents; cellular attractants and attachment agents; immunosuppressants; bone resorption inhibitors and stimulators; angiogenic and mitogenic factors; bioactive factors that inhibit and stimulate secondary messenger molecules; cell adhesion molecules, cell-matrix and cell-cell adhesion molecules; secondary messengers, monoclonal antibodies specific to cell surface determinants on mesenchymal stem cells, clotting factors; externally expanded autograft or xenograft cells, nucleic acids and any combination thereof.

27. The osteoimplant of Claim 1, wherein the osteoimplant is lyophilized.

28. The osteoimplant of Claim 1 wherein the aggregate of elongate bone particles has been subjected to a compressive force of up to about 100,000 psi.

29. The osteoimplant of Claim 28, wherein the osteoimplant is lyophilized.

30. The osteoimplant of Claim 1 wherein exposed collagen of contacting surfaces of the elongate bone particles are additionally chemically linked to each other.

31. The osteoimplant of Claim 1 possessing at least one region of demineralized elongate bone particles and at least one region of nondemineralized elongate bone particles.

5 32. The osteoimplant of Claim 31 wherein the region of demineralized elongate bone particles defines at least a portion of the exterior surface of the osteoimplant and the region of mineralized elongate bone particles defines at least a portion of the interior of the osteoimplant.

33. The osteoimplant of Claim 1 which is swellable upon contact with body and/or irrigation fluids.

10 34. The osteoimplant of claim 1 and substantially as hereinbefore described with reference to the accompanying Figures.

OSTEOTECH, INC.

WATERMARK PATENT & TRADE MARK ATTORNEYS

P26464AU00

Fig. 1

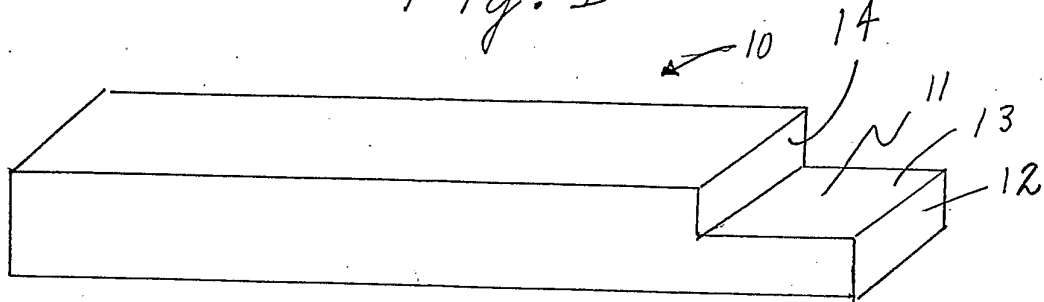

Fig. 2

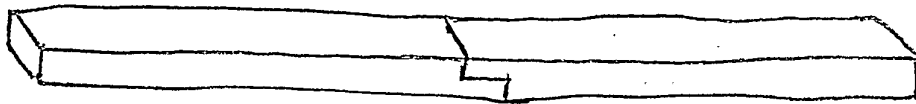

Fig. 3

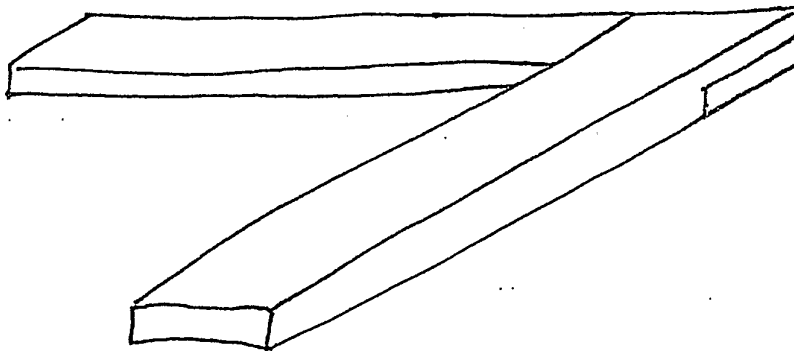

Fig. 4

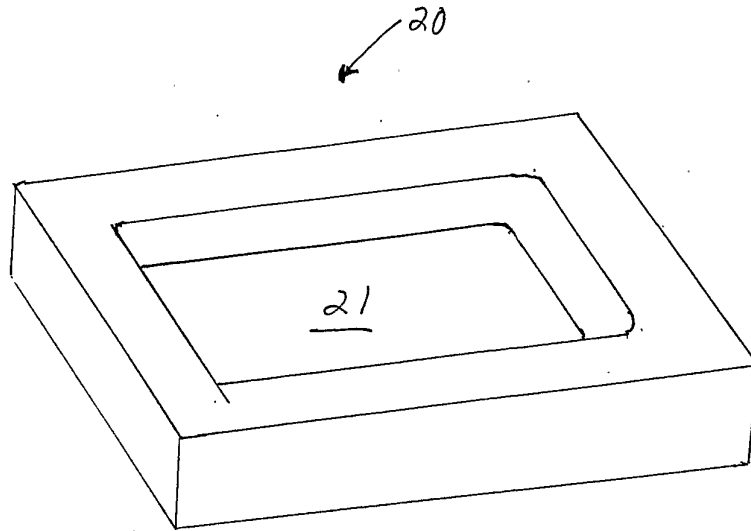

Fig. 5

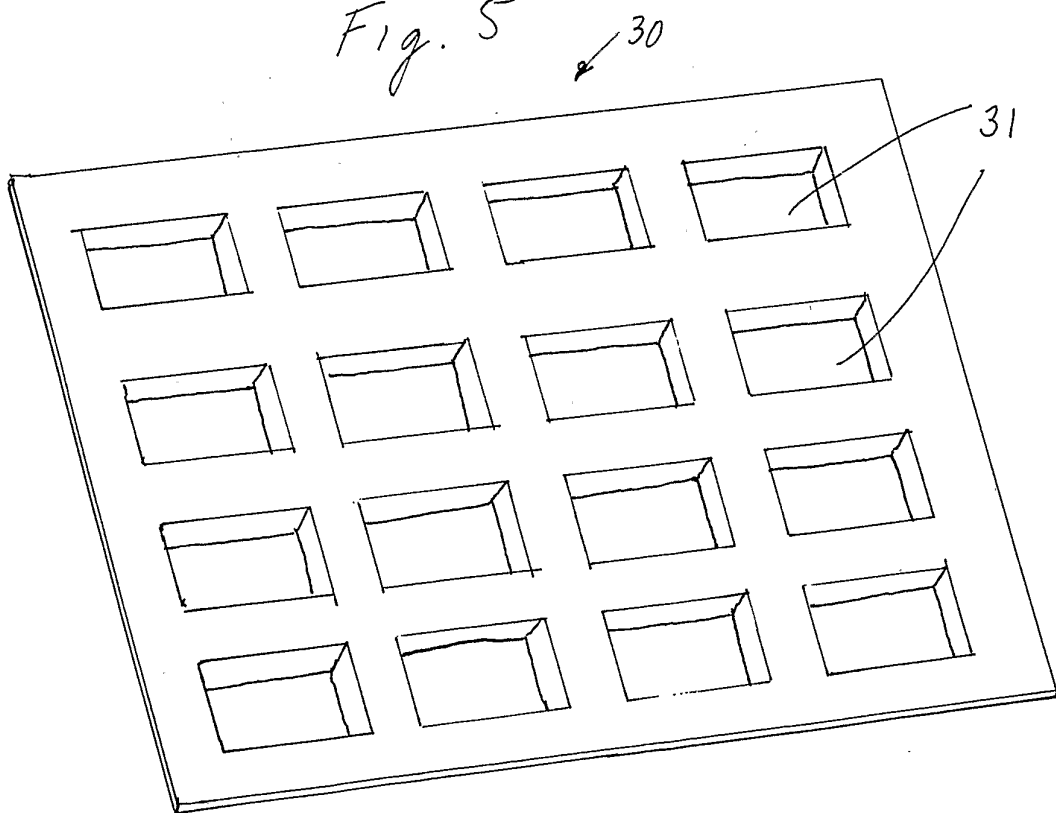

Fig. 6

40

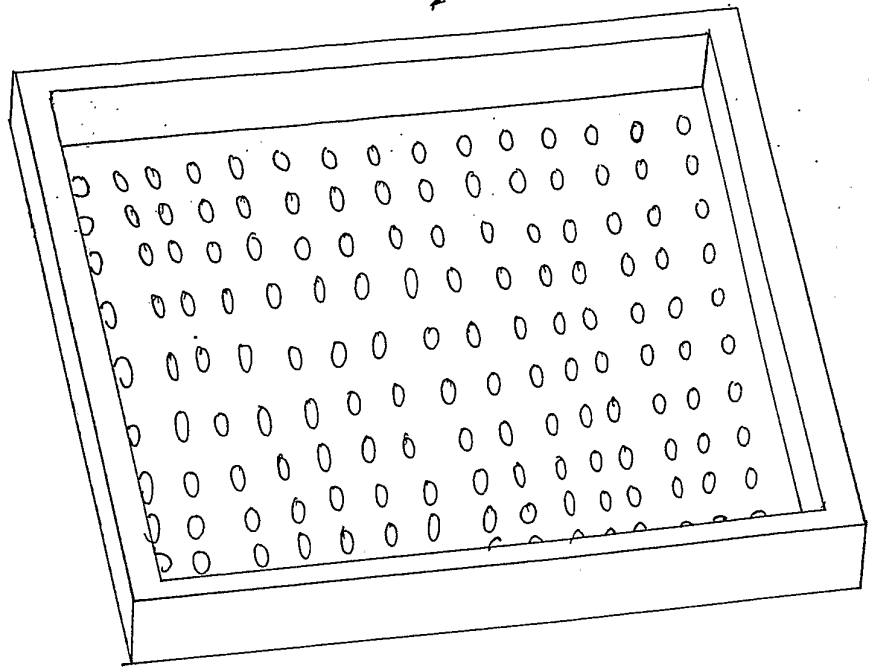

Fig. 7

50

