

(19)
(12)

(KR)
(A)

(51) 。 Int. Cl.7
H01M 2/30

(11)
(43)

2003-0095519
2003 12 24

(21) 10-2002-0032762
(22) 2002 06 12

(71) 1261-3 2 304

(72) 가 483-42

912-201

880 606-1601

(74)

:

(54) 2

2

2 가 , 2 가
1 ; (b) 가 ; (a)
1 ; (c)
1 ; (d) 1 2
; (e) 2 가 2 1 2

5

1 2 .

2a 2 .

2b 2 .

3 2 .

4 2 .

5 4 .

6 4 5 .

7a 7h 2 .

8 2 .

9 8 , .

10 8 .

11 8 1 .

12 8 2 .

13 15 2 .

16 15 2 .

17 2 .

< >

100... 2 110... 120...

130... 141... 143...

145... 147... 171... 1

173... 2 250... 3

2
가 , ,

2
2
PC
가 /
2
2
1 2
1 2 (10) (20) (40)
Unit Cell)(28) (20) , 2a (22)/ (24)/ (26) ((21)/ (23)/ (25)/ (23)/ (21)/
(23)/ (25) (Bi-Cell)(27) 가
1 (20) (12) (14) (12)
(16) (11) (14)
(18) (13) (11)(13)
(15) (15) (17)
1 3 (40) (20) (32) ((34) (16)(18) 2 (38) (17) 1 (34)
(short) () (40) (11)(13)
3 2 (10) , 가
가 (d₁) (34) (d₂) (d) / (12)(14) 2 (38)
(16)(18) (19) 2 (10) (20) 1 (36) (d₃)
2 (38) 가 (Dead Space) 가 2 (12)(14) /
3 (40) (16)(18) (11)(13)가 (19) /
(12)(14) 가 (40)가 2 (10)
(19) 가 (12)(14)
가
가
가
2 2

가 ; (b) 2 가 , (a)

가 ; (a) ; (b)

가 ; (c)

가 ; (a) 1

가 ; (b)

가 ; (c) ; (d) 1 1

가 ; (e) 1 2 가 1 2 가 1 1

가 2 , ,

가 2 , 1 ,

가 2 , 2 1

가 2 , 1 2

가 2 ,

가 / (Fold/Fold) ;

가 ; 가 ,

가 2 /

가 2 ,

가 2 ;

가 2

가 2

2

7a 7h 8

7a 8 (110) (141) (S20) (145) (143) 2 (S3)

10) (141) (143) 1 (S40), (143) 2 (S50)

S10 (141) (110) 1 (116)

7a (110) (141) (141)

(143) (141)

S10 9 7a (110) (150) (141) 7b (141)

(151) (110) 1 (116) 1 (116)

7c 41 (110) 가 7d (160) (1)

S20 (142) (144) (143) 7d (110) (143)

(141) (141) (143) (141) (143) (144) 가

(145) 1.0mm 2.5mm 가 가

가

S30 7f 10 (141) (143)가 (120) (145) (14)

(6 127) (145) (100)가 (147) () 가 가

7) (145) (147) (147) (145) 가 (141)

(143) (141) (145)

S40 7g 11 (110) 1 (116) 2 (118)

(141) 가 2 (118) 1 (171) 11

'A' 1 (171) (147)가 (145) (141)

(147)가 (141) (141)

() (147)

1 (171) (147)

(141) (141)

가 1 (171) (141)가 (147)가

S50 7h 12 (143) 1 (171) 가 1 (116)

(145) 2 (173) 'B' 2 (173)

(145) 1 (171) (145)

(147) (143) (143)가 (145) (171) , 1 (171)
 2 (173) (143) (110) () , 가
 , 1 (171) 2 (173) (147)가 1 (147) (171) (141) , 2
 (173) (143)
 , 4 5 , 2 (100) , (147)
 , 1 (171) 2 (173)가 (141) (143)가 (147) (143)
 (141) (147) (143)
 13 15 2 2
 , 16 15 2
 3 (250) (210) 2 (200) , 1 (220) 2 (240) ()
 210) 2 (200) 3
 3 (211) 가 가 가 , (245) 가
 (/) (230)
 , (243) (242) , 16 13 14 (250)
 (247) (243)가 (247)
 (147)
 17 2
 17 , (310) (311) (313) (3)
 15) 가 (310) (320) (322) (315) () (317)
 2 (300)가
 , (310) 2 ()
 300)
 2 가 .
 , 2 가
 , 가
 , 2 가 (Dead Space)
 가 .
 , 가 .

(57)

1.

(a) ;

(b) 가 2 .

2.

(a) 가 ; 가

(b) ;

(c) 2 .

3.

(a) , 가 가 ;

(b) 1 가 ;

(c) 가 ;

(d) 1 2 가 2 ;

(e) 1 가 1 2 . 2

4.

1 3 , 가 2 .

5.

3 , 1 1,2 2 , 1,2 가 .

6.

3 5 , 2 가 1 1,2 2 .

7.

3 ,
1 2 2
2

8.
2 3 ,

;
;

/ (Fold/Fold)

가

;

2

9.
8 ,

/

(wrapping)

2

10.
2 3 ,

2

11.
1 3 5 7 2 .

12.
10 ;

가

2

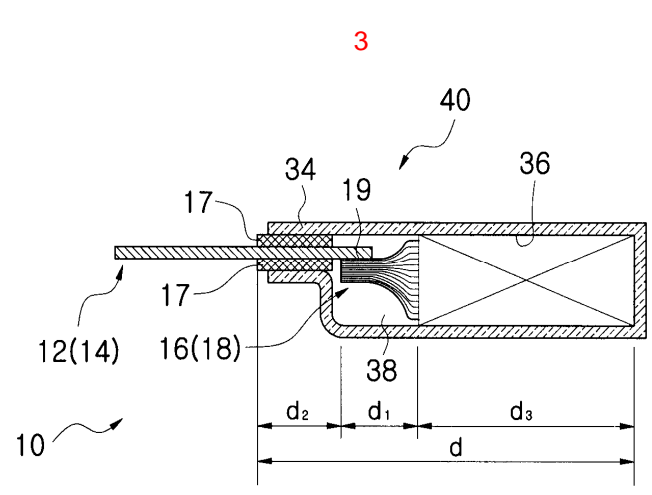
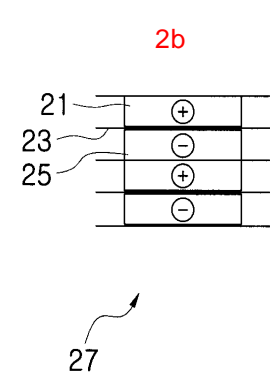
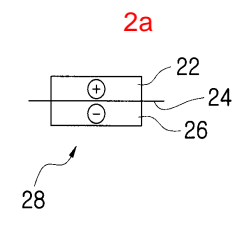
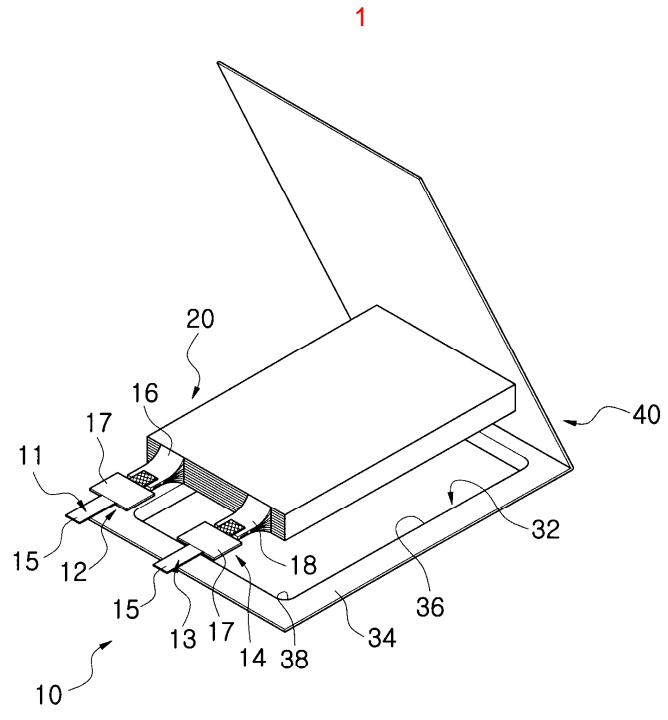

7a

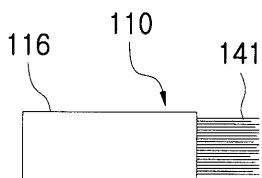

7b

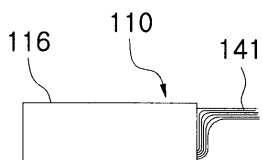

7c

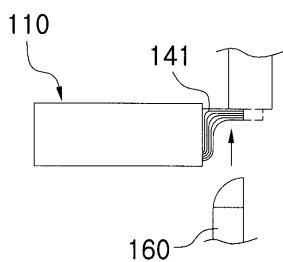

7d

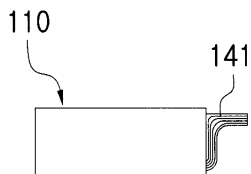

7e

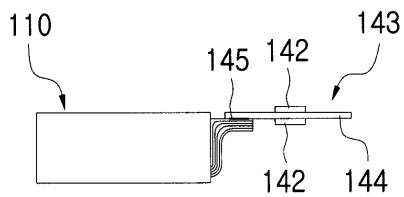

7f

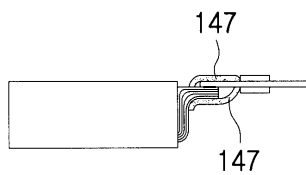

7g

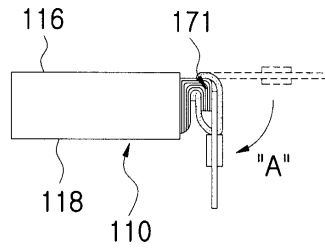

7h

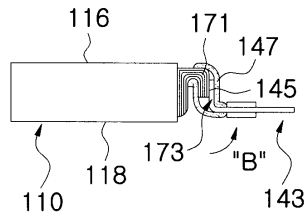

8

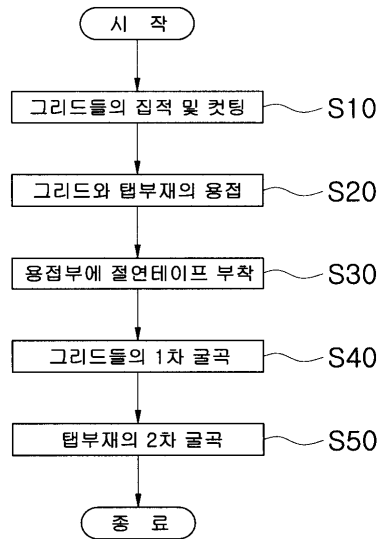

9

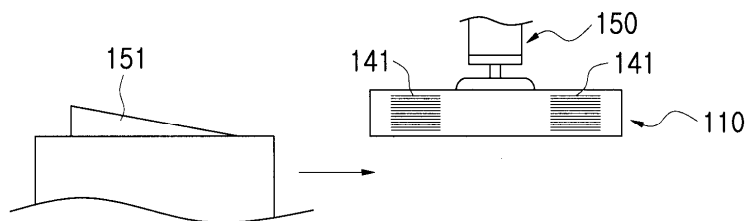

14

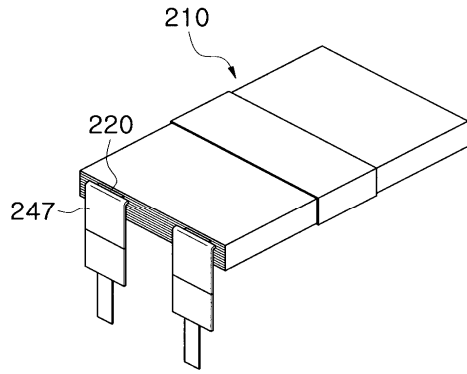

15

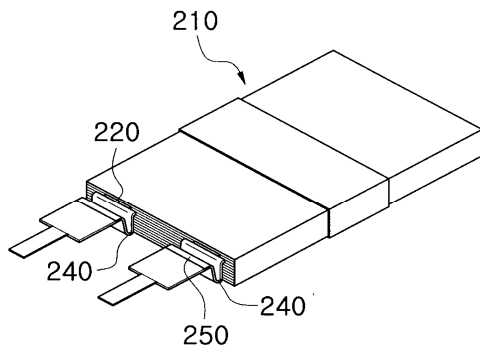

16

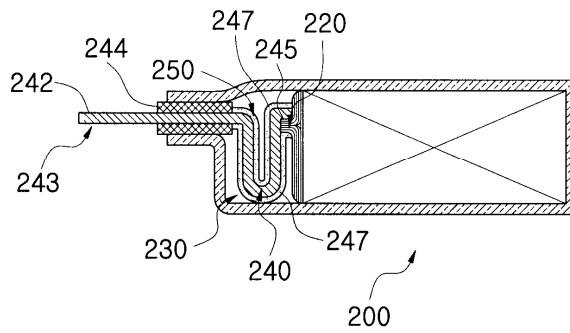

17

