

J. P. JONES.  
BINDING POST.

(Application filed May 7, 1898.)

(No Model.)

Fig. 1.

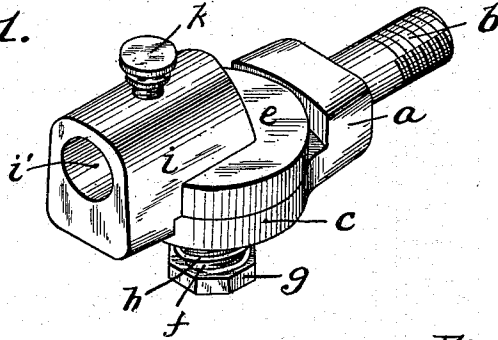

Fig. 2.

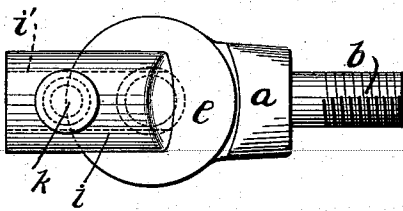

Fig. 3.

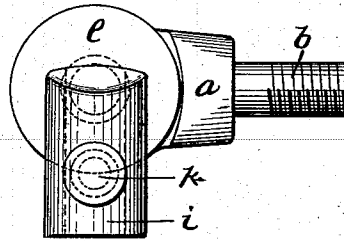

Fig. 4.

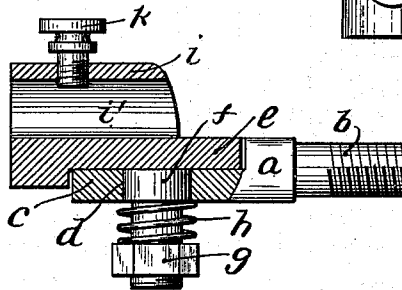
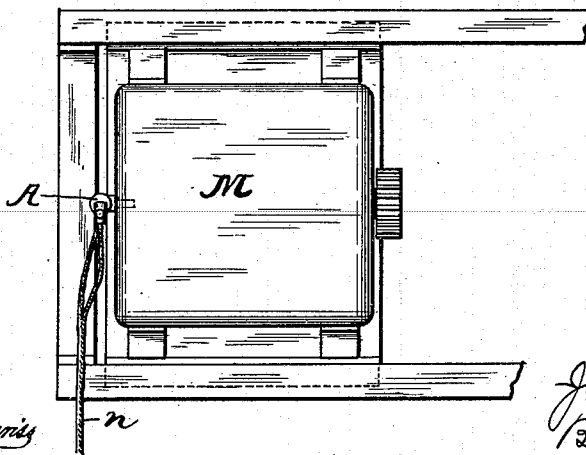

Fig. 5.



Witnesses:

Walter Samsonis  
G.C. Raymond

Inventor:

John P. Jones  
By Kay & Yntema  
Attorneys.

# UNITED STATES PATENT OFFICE.

JOHN P. JONES, OF WEBSTER, PENNSYLVANIA, ASSIGNOR OF ONE-HALF TO  
J. W. BLOWER, OF SAME PLACE.

## BINDING-POST.

SPECIFICATION forming part of Letters Patent No. 615,455, dated December 6, 1898.

Application filed May 7, 1898. Serial No. 680,001. (No model.)

To all whom it may concern:

Be it known that I, JOHN P. JONES, a resident of Webster, in the county of Westmoreland and State of Pennsylvania, have invented a new and useful Improvement in Binding-Posts; and I do hereby declare the following to be a full, clear, and exact description thereof.

My invention relates to binding-posts for electric wires.

The object of my invention is to provide a binding-post especially applicable for use in connection with machines which are shifted from one position to another, so that the binding-post itself will be capable of shifting its position in such manner that the wires leading to the machine will not have to make any abrupt bends, whereby the strain on the wires is relieved and they are not liable to be broken.

To enable others skilled in the art to make and use my invention, I will describe the same more fully, referring to the accompanying drawings, in which—

Figure 1 is a perspective view of my improved binding-post. Fig. 2 is a plan view. Fig. 3 is a plan view showing socket in a different position. Fig. 4 is a sectional view of the socket. Fig. 5 is a plan view of a portion of a mining-machine, showing my invention as applied to the motor for operating same.

Like letters indicate like parts in each of the figures.

The letter *a* designates the body portion of the binding-post, said body portion consisting of the projection *b* and the horizontal circular bearing-plate or seat *c*, having the opening *d*. Mounted to turn on the bearing-plate *c* is the circular plate *e*, said plate having the stud *f*, passing down through the opening *d* in the bearing-plate *c*. A nut *g* engages the threaded end of the stud *f*, and a spring *h* is interposed between the lower face of the bearing-plate *c* and said nut. By screwing up the nut *g* any wear may be taken up and the tension of the spring increased.

The socket *i* is attached to the plate *e* and is preferably formed integral therewith. This socket has the seat *i'*, adapted to receive the wire or cable. A set-screw *k* passes through the socket *i* into the seat *i'*, said set-screw be-

ing adapted to bear against and clamp the wire or cable within the socket.

As my invention has proven to be of great value in connection with mining-machines operated by electric motors, I will describe its operation in connection with such a machine. In Fig. 5 I have illustrated the rear portion of such a mining-machine, with the motor *M* mounted thereon. As is well known, in the ordinary type of these machines the motor is mounted on a carriage or movable frame, which carries the cutter-chain and the feed mechanism for feeding the cutter-chain into the coal, and accordingly the motor travels with said carriage. In the mines there is a main hallway with rooms communicating therewith in which the cutting is done. The hallway is fitted up with the main conductors which supply the current to operate the motor of the machine. The machine is taken into one of these rooms and is placed in position for cutting. Separate sections of cable *n* are then connected up with the main conductors and with the motor *M*. Two of the binding-posts *A* on the motor receive the ends of these cables *n* in their sockets, and they are held therein by the set-screws. As these cables *n* enter the rooms at right angles to the hallway, the socket *i* will turn to correspond to the angle at which the cables *n* enter the room. The consequence is that the cables are not bent where they enter the sockets, as in the case of a rigid socket. As these cables are usually made up of a number of small wires, where they are bent to enter the socket the small wires are liable to break and the full efficiency of the motor is destroyed. Then again the strain on the cables is so great that they have to be soldered into the sockets, so as not to be torn therefrom. This is a matter of much trouble and expense and is entirely obviated by my improved binding-post. As the motor travels with the carriage, the socket *i* moves also and conforms to the changing angle of the cable. All liability of the breaking of the wires of the cable is avoided, and as the pull is greatly reduced the necessity of soldering the cable in the socket is done away with.

What I claim as my invention, and desire to secure by Letters Patent, is—

In a binding-post, a body portion having a bearing-plate with an opening formed therein, a socket having a plate with a stud extending therefrom adapted to enter said opening, a  
5 nut on said stud and a spring interposed between said nut and bearing-plate, substantially as set forth.

In testimony whereof I, the said JOHN P. JONES, have hereunto set my hand.

JOHN P. JONES.

Witnesses:

JNO. M. CAMPBELL,

J. W. BLOWER.