

F. H. SCHLAPBACH.
 SLIDING DOOR AND WINDOW FASTENER.
 APPLICATION FILED JULY 12, 1909.

939,174.

Patented Nov. 2, 1909.

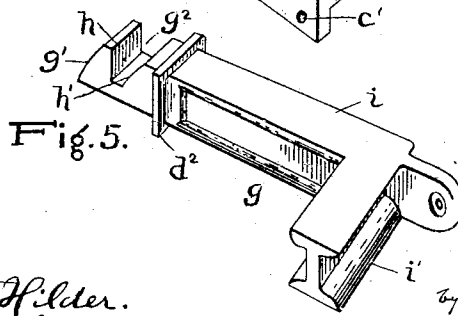
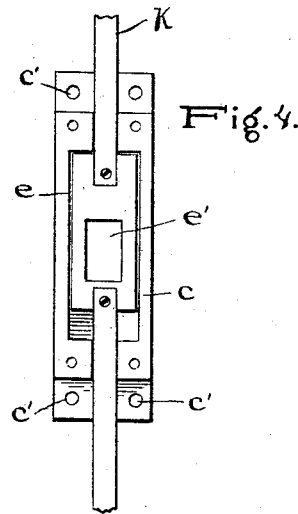
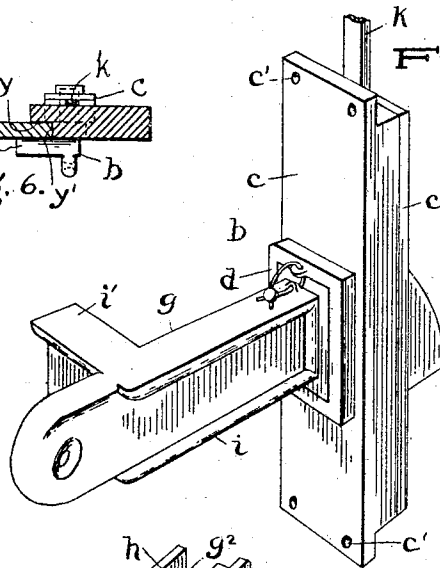
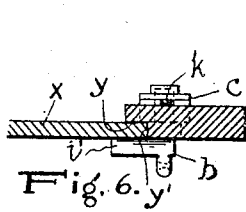
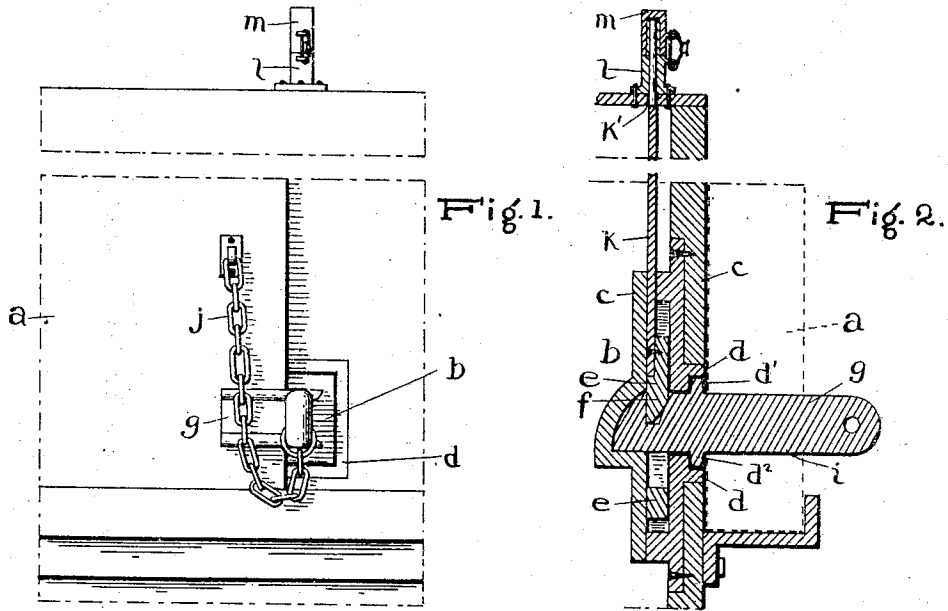

Witnesses
 Stuart Hilder.
 Francis M. Anderson.

Inventor
 F. H. Schlapbach
 E. W. Anderson for
 his Attorneys

UNITED STATES PATENT OFFICE.

FREDERICK H. SCHLAPBACH, OF ROME, GEORGIA, ASSIGNOR OF ONE-HALF TO EDWARD FULLER, OF CEDARTOWN, GEORGIA.

SLIDING DOOR AND WINDOW FASTENER.

939,174.

Specification of Letters Patent.

Patented Nov. 2, 1909.

Application filed July 12, 1909. Serial No. 507,225.

To all whom it may concern:

Be it known that I, FREDERICK H. SCHLAPBACH, a citizen of the United States, resident of Rome, in the county of Floyd and State of Georgia, have made a certain new and useful invention in Sliding Door and Window Fasteners; and I declare the following to be a full, clear, and exact description of the same, such as will enable others skilled in the art to which it appertains to make and use the invention, reference being had to the accompanying drawings, and to letters or figures of reference marked thereon, which form a part of this specification. Figure 1 is a front view of the invention as applied. Fig. 2 is a central vertical section of the same, showing the car door in dotted lines. Fig. 3 is a perspective view of the invention with parts broken away. Fig. 4 is a rear view of the casing with back plate removed to show the keeper plate, which is shown as provided with a downward extending operating rod connection. Fig. 5 is a detail perspective view of the locking bolt. Fig. 6 is a sectional view showing a modified form of the invention.

The invention has relation to locks for railroad car doors having for its object the provision of a lock of simple and efficient character which is designed to be incapable of being picked; for operation from the top of the car where the operator may be readily seen by the watchman on guard; and to guard against the door being wrenched from its track from below.

Other objects and advantages will hereinafter appear.

In the accompanying drawings illustrating the invention, the letter *a*, designates the usual sliding car door, and *b*, is the lock to be applied thereto. This lock comprises a hollow casing *c*, which is bolted to the side of the car at *c'*, *c'*, having an outward projecting hollow boss *d*, shown as of rectangular character and which projects through the car sheathing, lying flush with the outer surface thereof, or it may be slightly inset within the same. Within the hollow casing works a keeper or vertically slidable catch plate *e*, having a central opening *e'*, for the reception of the locking bolt said catch plate having an upper beveled shoulder *f*, with which said bolt engages. The locking bolt *g*, is provided with a beveled head *g'*, designed for engagement with the beveled

shoulder *f*, of the catch plate, and in rear of said head with a notch *g²*, having a straight wall *h*, fitting against the rear wall of the keeper, and an inclined wall *h'*, fitting against the beveled wall of said shoulder, with which it is held in close engagement. This bolt is further provided with an outer shank extension *i*, designed for engagement with the rear edge of the door to prevent its being opened, and a right-angle end-extension *i'*, fitting over the face of the lower rear corner of the door to prevent the door being wrenched outward from its trackway.

The car door being first slid into shut position over the casing *c*, until such casing is exposed at the rear edge of the door, the bolt *g*, which is attached to the side of the door by a chain *j*, is inserted within the opening of the boss *d*, of the casing, located at the lower rear corner of the door frame, into engagement with the beveled shoulder of the keeper aforesaid, which is automatically raised and falls again through force of gravity, effectually confining the bolt against removal. The door is thus prevented from being slid back or opened by abutment of the shank of the bolt against the rear door edge, while the right-angle extension lying over the rear lower corner of the door prevents wrenching open of the door from below. The boss *d*, is provided with a rabbeted seat *d'*, surrounding its opening and in which fits a collar or flange extension *d²*, of the locking bolt, which in connection with the close fit of the bolt in the boss opening effectually prevents entrance of any tool or wire for purpose of picking the lock. The slidable clutch-plate *e*, is provided within the car with an upward extending operating rod *k*, running the height of the car and passing through an opening *k'*, in the car roof, where it passes through a socket piece *l*, bolted to the roof of the car and having a reduced or rabbeted upper end portion over which fits a cap piece *m*, to which the upper end of the operating rod is fixed in any suitable way. Thus when the door is to be released, the operator upon the top of the car lifts the cap piece *m*, and the rod *k*, and keeper plate attached, when the bolt may be removed from its seat and the door opened.

The lock is equally applicable to the sliding cover for a window such as the end window of a car, which requires to be closely guarded, when the lock would be operated

from the inside of the car, by pushing up the sliding keeper plate from below as shown in Fig. 4 of the drawings.

The lock may of course be made of any suitable size and material and applied to any form of door.

In Fig. 6 of the drawings is shown a modified form of the invention, wherein the door or window frame is formed with a rabbeted seat y , for the door or window x , said door or window having abutment against the edge wall y' , of said seat to prevent any sliding movement toward open position, and the right-angle end-extension of the locking bolt which in this form of the invention is shortened, having engagement with the face of the lower corner of the door as before stated for the main form of the invention.

Having thus described the invention, what I claim as new and desire to secure by Letters Patent is:

1. The combination with a hollow structure having an opening provided with a cover, of a locking device for keeping said cover in closed position, comprising a reciprocatory keeper-plate located within the structure, a casing for the keeper-plate having an opening without the structure, a locking bolt having a notched head for engagement with said keeper-plate and an external right-angle end-extension engaging the face of an edge portion of the cover.

2. The combination with a railroad car having a sliding door, of a locking device

for keeping said door in closed position, having an external right-angle end-extension engaging the face of an edge portion of the door, and means for releasing said locking device having a concealed operating rod located within the car and having extension through the roof thereof.

3. The combination with a railroad car having a sliding door, of a locking device for keeping said door in closed position, comprising a sliding keeper-plate located within the car, a casing for the keeper-plate having an external opening, a locking bolt having a notched head for engagement with said keeper-plate and an external right-angle end-extension engaging the face of an edge portion of the door, and a concealed operating rod located within the car and having extension through the roof thereof.

4. The combination with a railroad car having a sliding door, of a locking device located at and having abutment against the rear edge of the door to prevent opening of the same, said locking device having an angular extension engaging the face of the lower rear corner of the door, and means for releasing said locking device accessible only from the top of the car.

In testimony whereof I affix my signature in presence of two witnesses.

FREDERICK H. SCHLAPBACH.

Witnesses:

RICHARD A. CURTIN,
STUART HILDER.