

ADJUSTABLE INTRAOCULAR LENS

CROSS-REFERENCE TO RELATED APPLICATIONS

[0001] This application claims priority to U.S. Provisional Patent Application Serial No. 61/042,293, filed April 4, 2008, and U.S. Provisional Patent Application Serial No. 61/090,339, filed August 20, 2008. The disclosures of these two applications are hereby fully incorporated by reference herein.

BACKGROUND

[0002] The present disclosure relates to methods and devices that are useful for adjusting the optical power of a lens, particularly an intraocular lens that can be implanted in the eye.

[0003] The lens of the eye is used to focus light on the retina. The lens is usually clear, but can become opaque (i.e. develop a cataract) due to age or certain diseases. The usual treatment is to surgically remove the opaque lens and replace it with an artificial or intraocular lens.

[0004] It is desirable to be able to adjust the lens after it has been implanted. Such adjustments are useful in correcting misplacement of the lens during the surgical operation and/or to treat higher order optical aberrations. A common method is to use ultraviolet (UV) activation to induce the change in lens performance, to allow for high spatial resolution of the adjustment (due to the low wavelength of UV). After the lens is adjusted, the lens should not appreciably change in performance over the lifetime of the lens.

[0005] U.S. Patent No. 7,134,755 describes a lens that uses ultraviolet light curable monomers in a silicone polymer matrix. The monomers are selectively polymerized using a digital light delivery system to alter the lens power at specific points.

[0006] There are two distinct effects that alter the lens optical power in this system. First, the polymerization of the UV curable monomers changes the refractive index of the system from $n=1.4144$ to $n=1.4229$, which would increase the optical power of the test lens from 95.1 diopters to 96.7 diopters. This change in the lens power is much

smaller than the change in lens power that was reported in the patent, indicating this is not the primary mechanism of index change in this patent.

[0007] The second effect, which is responsible for the largest component of the change in lens optical power, is a swelling of the lens in the irradiated region. This swelling effect is illustrated in **FIG. 1**.

[0008] In **FIG. 1A**, free monomers (denoted M) are present in a silicone polymer matrix **10**. In **FIG. 1B**, a mask **20** is used to expose only a portion **30** of the lens to UV radiation. The monomers in the region exposed to the UV radiation undergo polymerization, forming polymers P and slightly changing the refractive index. Over time, as seen in **FIG. 1C**, monomers from the un-exposed regions **40**, **50** then migrate into the exposed region **30**, causing that region to swell. This change in the lens thickness then leads to a larger change in the optical power. In **FIG. 1D**, after the migration of the monomer is finished, the whole lens is then exposed to UV radiation to freeze the changes.

[0009] There are several shortcomings to this method. One is that the primary change in the lens optical power is due to diffusion of monomer, which is a relatively slow process. Another shortcoming is that the dependence on diffusion as the operative effect limits the spatial resolution of the changes in the lens optical power. A third shortcoming is that the increase in lens thickness in the exposed region forces a thickness decrease in adjacent regions, as monomer from the adjacent region diffuses into the exposed region. This change in thickness in the adjacent regions is not easily controllable. Lenses without these shortcomings and others are desirable.

BRIEF DESCRIPTION

[0010] Disclosed in various embodiments are devices and methods for adjusting the optical power of a lens. Among other benefits, these lenses do not contain free monomers, so there is no change in lens shape due to diffusion of monomers. There is also no need for a second UV radiation exposure of the total lens to "lock-in" the refractive index changes.

[0011] Disclosed in some embodiments is an intraocular lens comprising: a single polymer matrix having crosslinkable pendant groups, wherein the polymer matrix

increases in volume when crosslinked; and wherein substantially no free monomers are present therein.

[0012] The lens may further comprise a UV absorbing layer on at least one surface of the lens.

[0013] The pendant group may be 3,9-divinyl-2,4,8,10-tetraoxy-spiro[5.5]undecane.

[0014] Disclosed in other embodiments is an intraocular lens comprising a polymer matrix including photobleachable chromophores.

[0015] The photobleachable chromophores may be dispersed within the polymer matrix, or be present as pendant groups on the polymer matrix.

[0016] At least one chromophore may comprise a reactive site which can crosslink with a reactive site on the polymer matrix.

[0017] The photobleachable chromophores may comprise chromophores containing a malononitrile moiety, such as those of Formula (I) or Formula (II):

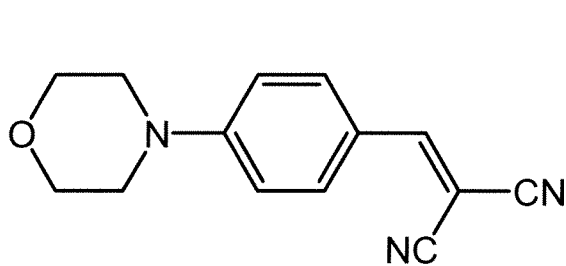

Formula (I)

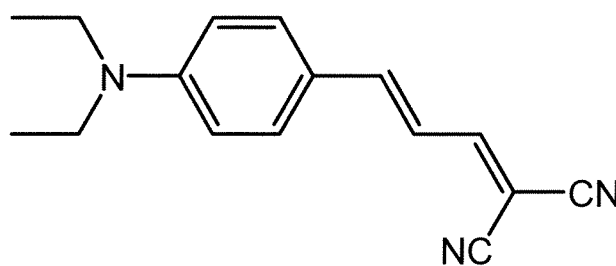

Formula (II)

[0018] Alternatively, the photobleachable chromophores may comprise stilbene chromophores of Formula (III):

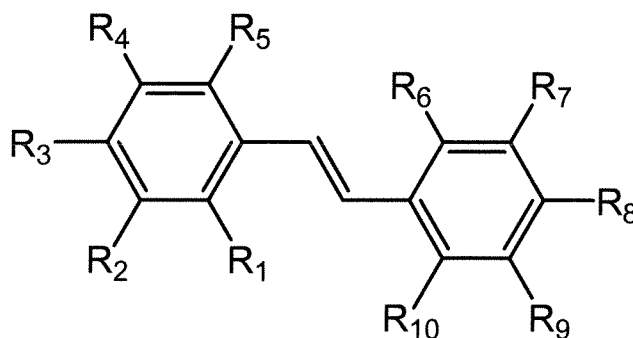

Formula (III)

where R_1 - R_{10} are independently selected from hydrogen, alkyl, substituted alkyl, aryl, substituted aryl, $-COOH$, and $-NO_2$.

[0019] Alternatively, the photobleachable chromophores may comprise azobenzene chromophores of Formula (IV):

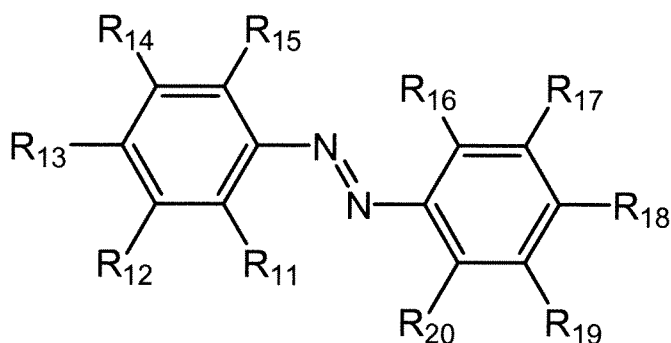

Formula (IV)

where R₁₀-R₂₀ are independently selected from hydrogen, alkyl, substituted alkyl, aryl, substituted aryl, -COOH, -NO₂, halogen, amino, and substituted amino.

[0020] In other embodiments, at least one chromophore must absorb more than one photon for photobleaching of the chromophore to occur.

[0021] Disclosed in still other embodiments is a method of altering the optical power of a lens, comprising: providing a lens comprising: a single polymer matrix having crosslinkable pendant groups, wherein the polymer matrix increases in volume when crosslinked; and wherein the lens is devoid of free monomers; and exposing a portion of the lens to radiation, causing crosslinking to occur in the exposed portion of the lens and increasing the refractive index of the exposed portion of the lens, thereby altering the optical power of the lens.

[0022] The exposed portion of the lens may be in the center of the lens. The radiation to which the lens is exposed may have a wavelength of from about 200 nm to about 600 nm.

[0023] In other embodiments is disclosed a method of altering the optical power of a lens, comprising: providing a lens comprising a polymer matrix having photobleachable chromophores; and exposing a portion of the lens to radiation, causing photobleaching to occur in the exposed portion of the lens and decreasing the refractive index of the exposed portion of the lens, thereby altering the optical power of the lens.

[0024] These and other non-limiting aspects and/or objects of the disclosure are more particularly described below.

BRIEF DESCRIPTION OF THE DRAWINGS

[0025] The following is a brief description of the drawings, which are presented for the purposes of illustrating the disclosure set forth herein and not for the purposes of limiting the same.

[0026] **FIGS. 1A-1D** are illustrations of a conventional method for adjusting lens optical power.

[0027] **FIG. 2** is a graph showing a normalized change in lens optical power as a function of the refractive index of the lens in both air and water.

[0028] **FIGS. 3A-3B** are illustrations of one method of the present disclosure for altering the optical power of a lens.

[0029] **FIG. 4** is a graph showing the change in the refractive index as a function of the change in the volume of a polymer used to make the lens.

[0030] **FIG. 5** is a graph showing the change in the lens optical power as a function of the change in the volume of a polymer used to make the lens.

[0031] **FIGS. 6A-6B** are illustrations of another method of the present disclosure for altering the optical power of a lens.

[0032] **FIG. 7** is a graph of the solar spectrum, showing the amount of energy at each wavelength.

[0033] **FIG. 8** is a graph showing the photon flux and the chromophore lifetime as a function of the wavelength.

[0034] **FIGS. 9A-9C** are three figures describing bleaching via two-photon absorption by a chromophore.

[0035] **FIG. 10** is a cross-sectional view of an exemplary embodiment of a lens of the present disclosure.

[0036] **FIG. 11** is an idealized transmission spectrum for a UV radiation absorbing layer of the present disclosure.

[0037] **FIG. 12** is a graph showing the refractive index of a lens as a function of the amount of time the lens was exposed to UV radiation.

[0038] FIG. 13 is a graph showing the transmission spectrum of a contact lens before application of a chromophore, before bleaching, and after bleaching.

DETAILED DESCRIPTION

[0039] A more complete understanding of the processes and apparatuses disclosed herein can be obtained by reference to the accompanying drawings. These figures are merely schematic representations based on convenience and the ease of demonstrating the existing art and/or the present development, and are, therefore, not intended to indicate relative size and dimensions of the assemblies or components thereof.

[0040] Although specific terms are used in the following description for the sake of clarity, these terms are intended to refer only to the particular structure of the embodiments selected for illustration in the drawings, and are not intended to define or limit the scope of the disclosure. In the drawings and the following description below, it is to be understood that like numeric designations refer to components of like function.

[0041] The modifier "about" used in connection with a quantity is inclusive of the stated value and has the meaning dictated by the context (for example, it includes at least the degree of error associated with the measurement of the particular quantity). When used with a specific value, it should also be considered as disclosing that value. For example, the term "about 2" also discloses the value "2" and the term "from about 2 to about 4" also discloses the range "from 2 to 4."

[0042] References to ultraviolet or UV radiation should be understood as referring to the portion of the light spectrum having wavelengths between about 400 nm and about 10 nm.

[0043] The "refractive index" of a medium is the ratio of the speed of light in a vacuum to the speed of light in the medium. For example, the refractive index of a material in which light travels at two-thirds the speed of light in a vacuum is $(1 / (2/3)) = 1.5$.

[0044] The term "chromophore" refers to a chemical moiety in a molecule that imparts color to the molecule.

[0045] The term “photobleaching” refers to a change in the chromophore induced by photochemical means. Exemplary changes may be the cleavage of the chromophore into two or more fragments, or a change in the bond order of one or more covalent bonds in the chromophore, or a rearrangement of the bonds, such as a transition from a trans-bonding pattern to a cis-bonding pattern.

[0046] The optical power of a simple lens is given by the following Equation 1:

$$\frac{1}{f} = (n - n_0) \left[\frac{1}{R_1} - \frac{1}{R_2} + \frac{(n - n_0)d}{nR_1R_2} \right] \quad (1)$$

where $1/f$ is the optical power of the lens (measured in diopters or m^{-1}), n is the refractive index of the lens material, n_0 is the refractive index of the surrounding medium, R_1 and R_2 are the two radii of curvature of the lens, and d is the thickness of the lens.

[0047] The importance of change in the refractive index is shown in **FIG. 2**, which is a graph showing the normalized change in lens optical power as a function of the refractive index for a lens placed both in water and air (normalized by the lens power at $n=1.5$). The calculations were performed using $R_1=0.00185$ m, $R_2=0.00255$ m, $d=300$ μ m, n_0 for water=1.3374, and n_0 for air=1.0000.

[0048] In some methods of the present disclosure, crosslinking is used to change the refractive index of the lens. The lens thickness may either slightly shrink or increase, but the lens curvature is not appreciably altered. The primary change in lens optical power comes from the change in refractive index, not from the change in lens thickness or curvature. This is illustrated in **FIG. 3**. In **FIG. 3A**, the lens **100** contains a polymer matrix (denoted as P) having crosslinkable pendant groups (denoted as X). A mask **105** is used to expose only a portion **110** of the lens to UV or other radiation. As seen in **FIG. 3B**, crosslinking occurs in the exposed portion **110** of the lens, changing the refractive index of the exposed portion.

[0049] An intraocular lens which is useful in this method may comprise a conventional polymer capable of behaving as a hydrogel, i.e. which can swell upon contact with water. Typically, crosslinking a conventional polymer decreases the volume of the polymer, similar to the decrease in volume upon polymerization (i.e. a

decrease in thickness occurs). This reduction in volume leads to an increased refractive index. However, there are monomers, such as 3,9-divinyl-2,4,8,10-tetraoxy-spiro[5.5]undecane (shown below), which expand under photopolymerization.

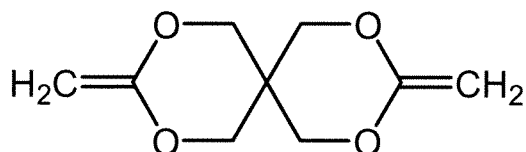

3,9-divinyl-2,4,8,10-tetraoxy-spiro[5.5]undecane

Including similar functional groups as reactive sidechains or pendant groups in the polymer may lead to an increase in volume upon crosslinking. After crosslinking these functional groups, the regions where the polymer volume has increased will have decreased refractive index, while areas where the polymer volume decreases will have increased refractive index. Put another way, the crosslinked regions of the lens have increased refractive index.

[0050] Alternatively, crosslinking a hydrogel controls the degree to which it can swell in the presence of water, preventing an increase in volume. After crosslinking, those regions where the hydrogel has been crosslinked will have an increased refractive index compared to the regions where the hydrogel has not been crosslinked.

[0051] Because the change in lens optical power of such intraocular lenses does not rely on diffusion of free monomers, the change in lens power can be monitored in real time. Millan in *Polymer* 46 (2005), pp. 5556-5568, discloses a crosslinked polystyrene which increases refractive index and thickness after crosslinking.

[0052] One approach to approximate the role of crosslinking on the optical properties of polymers is to use the Lorentz-Lorenz formalism, which expresses the refractive index in terms of a molar refractivity R_{LL} and molar volume V , as in Equation 2:

$$n = \left[\frac{1+2R_{LL}/V}{1-2R_{LL}/V} \right]^{1/2} \quad (2)$$

The effect of crosslinking is then treated as solely altering the molar volume, without changing the molar refractivity. **FIG. 4** shows the change in the refractive index associated with a change in the volume using Equation 2. **FIG. 5** shows the change in the lens power as a function of the change in volume. The calculations were performed using polymethyl methacrylate (PMMA) as the model compound, with $MW=100.117$, $R_{LL}=24.754$, and starting volume of $V=865$ (see van Krevelen, Properties of Polymers, 1976). The volume was systematically decreased and the refractive index was calculated. The lens power calculations were again performed using $R_1=0.00185$ m, $R_2=0.00255$ m, $d=300$ μm , n_0 for water= 1.3374 , and n_0 for air= 1.0000 . The calculated refractive index started at $n=1.48415$, and ended at $n=1.50129$ ($\Delta n=0.01714$, 1.15%).

[0053] **FIG. 5** shows that a change of up to about 10% in lens optical power can occur for a change in volume of less than about 3%, corresponding to a thickness change in the lens of less than about 1%. The calculations are fairly insensitive to whether the volume change is modeled as just corresponding to a thickness change, or is modeled as changing in all 3 dimensions equally.

[0054] In embodiments, the intraocular lens suitable for practicing this method may comprise a single polymer matrix containing crosslinkable pendant groups, wherein the polymer matrix increases in volume when crosslinked. The lens does not contain free monomers that diffuse between regions to increase the volume. Rather, the increase in volume is due to diffusion of water into the exposed (i.e. crosslinked) portion of the lens.

[0055] In embodiments, a method for altering the optical power of a lens comprises providing a lens comprising a single polymer matrix having crosslinkable pendant groups, wherein the polymer matrix increases in volume when crosslinked. The lens is devoid of, i.e. does not contain, free monomers. A portion of the lens is exposed to radiation, such as ultraviolet radiation. This causes crosslinking to occur in the exposed portion of the lens and changes the refractive index of the exposed portion. The refractive index may increase or decrease, and decreases in particular embodiments. In particular embodiments, the exposed portion is in the center of the lens.

[0056] In other methods of the present disclosure, ultraviolet (UV) radiation is used to photobleach the lens material. Certain aromatic groups, such as naphthalene, can degrade under UV radiation exposure. This leads to a decrease in the refractive index in these exposed regions, without any change in lens thickness. **FIG. 6** is a schematic of the photobleaching process. In **FIG. 6A**, the lens **100** contains a polymer matrix (denoted as P) having photobleachable chromophores (denoted as C). A mask **105** is used to expose only a portion **110** of the lens to UV or other radiation. As seen in **FIG. 6B**, the chromophores in the exposed portion **110** of the lens are bleached (denoted as B), lowering the refractive index of the exposed portion compared to the unexposed portions **120**, **130**. Photobleaching has exceptional spatial resolution, commonly on the order of a few microns. There is extensive literature on the design of chromophores to photobleach and on the design of optical materials with enhanced photostability.

[0057] The photobleaching of a material can be described using Equation 3:

$$\frac{B}{\sigma} = \tau n \quad (3)$$

where B is the probability of the degradation event happening, σ is the cross section, n is the photon flux, and τ is the lifetime of the chromophore. B/σ is often referred to as the photostability Figure-of-Merit (FOM). B/σ has strong energy dependence and also strong dependence on the maximum absorption wavelength (λ_{max}) of the chromophore.

[0058] The energy dependence can be approximated with Equation 4:

$$\log \left[\frac{B}{\sigma} \right] = 24 + 5.0 \times (E_{max} - E) \quad (4)$$

where E_{max} is the energy of the chromophore maximum absorption wavelength.

[0059] The next step in the chromophore lifetime calculation is determination of the maximum and average photon flux the lens will be exposed to. The solar spectrum has the form of **FIG. 7**, and is approximated by the solid line. Long wavelength radiation will be ignored in the determination, as it will have no effect on the photodegradation.

[0060] After conversion of the solar spectrum into photon flux, and using the energy dependent FOM expression assuming chromophore absorption maximum of 325 nm, the plot of the chromophore lifetime as a function of the energy in the solar spectrum can be obtained, and is shown as **FIG. 8**. The solid line is the chromophore lifetime, while the dotted line is the photon flux.

[0061] The total chromophore lifetime is obtained from the summation of the inverse lifetimes (the total degradation rate is the sum of the individual degradation rates). In this example, the total chromophore lifetime is calculated to be about 2.1×10^5 seconds. Notably, there is a rapid increase in lifetime as the wavelength increases. Much less than 1% of the photodegradation in this example arises from wavelengths longer than about 400 nm.

[0062] The previous calculation for the total chromophore lifetime assumes that the user stares directly into the noontime sun for the entire lens lifetime, which overestimates the total photon exposure during the lens lifetime. Using an ambient light level of 32,000 lux (average noontime level) for 9 hours, 9 hours of 400 lux (ambient office lighting) and 6 hours of sleep per day, the photon flux is calculated to be overestimated by a factor of 30, leading to a predicted lifetime for the lens of about 6.2×10^6 seconds. This lifetime is still shorter than desired ($\sim 2 \times 10^9$ seconds is desired), but literature precedent shows straight-forward methods to increase the lifetime by more than the three orders of magnitude needed.

[0063] The final issue is the amount of optical power available for the photobleaching. Based on 2006 *Trans. Am. Ophthalmol. Soc.* p. 29, where a power of 12 mW/cm^2 was used for 120 seconds ($\lambda=365\text{nm}$), the photon flux is $2.2 \times 10^{20}/(\text{m}^2 \cdot \text{sec})$, and the total photon exposure is $2.7 \times 10^{22}/\text{m}^2$. Staring into the sun, the photon flux below 400 nm is $7.6 \times 10^{19}/(\text{m}^2 \cdot \text{sec})$, the ambient noontime flux below 400 nm is approximately $2.5 \times 10^{19}/(\text{m}^2 \cdot \text{sec})$, and the average flux is $2.5 \times 10^{18}/(\text{m}^2 \cdot \text{sec})$.

[0064] In embodiments, an intraocular lens suitable for practicing this method comprises a polymer matrix containing photobleachable chromophores. The chromophores may be present as compounds dispersed within the polymer matrix or as pendant groups on the polymer matrix. The chromophores may contain a reactive site which can react with a reactive site on the polymer matrix to allow crosslinking.

[0065] In particular embodiments, the chromophore contains a malononitrile moiety. Exemplary chromophores include those of Formulas (I) and (II), which are also known as VC60 and EC24, respectively:

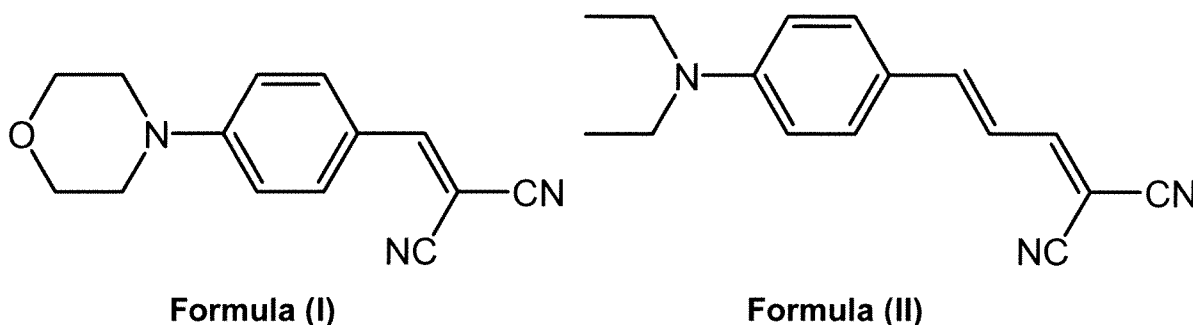

Formula (I) may also be called 4-morpholinobenzylidene malononitrile. Formula (II) may also be called 2-[3-(4-N,N-diethylanilino)propenylidene] malononitrile.

[0066] In other embodiments, the chromophore is a stilbene compound of Formula (III):

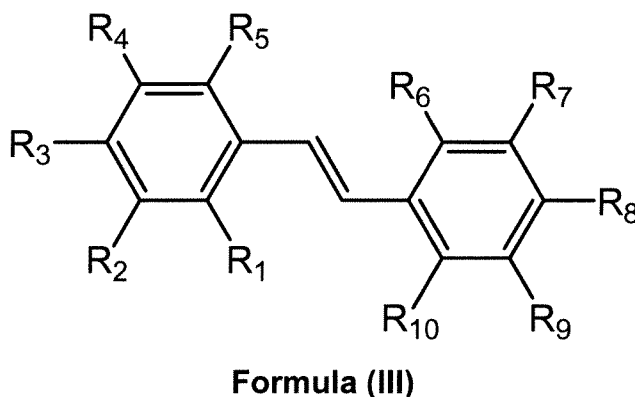

where R_1 - R_{10} are independently selected from hydrogen, alkyl, substituted alkyl, aryl, substituted aryl, $-\text{COOH}$, and $-\text{NO}_2$. The alkyl groups may be substituted with, for example, halogen. The aryl groups may be substituted with, for example, halogen and alkyl. Generally, the substituents R_1 - R_{10} are selected to enhance other properties of the chromophore. For example, R_1 , R_5 , R_6 , or R_{10} could be selected to be a crosslinkable group, such as a carboxylic acid. The substituents may also be selected as to control the absorption maximum and/or the refractive index of the chromophore, such as trifluoromethyl (to lower the refractive index), or a nitro group (to redshift the absorption maximum). The substituents may also be selected to enhance the photostability of the

chromophore. For example, inclusion of a bulky group at the 2 or 2' position, such as phenyl, inhibits trans-cis isomerization.

[0067] In other embodiments, the chromophore is an azobenzene compound of Formula (IV):

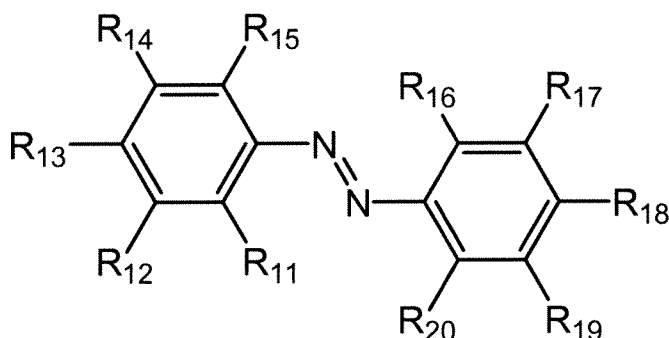

Formula (IV)

where R_{10} - R_{20} are independently selected from hydrogen, alkyl, substituted alkyl, aryl, substituted aryl, $-COOH$, $-NO_2$, halogen, amino, and substituted amino. The alkyl groups may be substituted with, for example, halogen. The aryl and amino groups may be substituted with, for example, halogen and alkyl. Generally, the substituents R_{10} - R_{20} are selected to enhance other properties of the chromophore.

[0068] In still other embodiments, the chromophore must absorb more than one photon for bleaching to occur. **FIG. 9** provides an explanation. As illustrated in **FIG. 9A**, the chromophore molecule has three energy levels, which include the ground state G, the first excited state B which can be accessed from the ground state by the absorption of a single photon ω_{max} , and the second excited state A which cannot be accessed from the ground state by a single photon absorption. Typically, there is an allowed transition between states B and A. The second excited state A is the state where the chromophore bleaches. Analysis of the one and two photon absorption spectra for simple chromophores indicates that the energy of state B relative to the ground state is approximately 0.85 of the energy of state A relative to the ground state (Marius Albota, *Science* 281, p. 1653 (1998)). **FIG. 9B** shows the energy spectrum for a standard two-photon absorption. In this process, two photons ω of the same wavelength are absorbed, when the energy of a single photon is too small to be directly absorbed. In this case, the absorption rate depends on the square of the optical

intensity. It is also possible to have a two photon absorption where the two photons are of different frequencies. This is shown in **FIG. 9C**, where two distinct photons ω_1 and ω_2 are absorbed, even though neither photon alone has sufficient energy to excite the molecule to even the first excited state B. In this case, the absorption intensity is proportional to the product of the intensity of each wavelength.

[0069] In embodiments, a method for altering the optical power of a lens comprises providing a lens comprising a polymer matrix containing photobleachable chromophores. A portion of the lens is exposed to radiation, such as ultraviolet radiation. This causes photobleaching to occur in the exposed portion of the lens and changes the refractive index of the exposed portion. The refractive index may increase or decrease, and decreases in specific embodiments. In particular embodiments, the exposed portion is in the center of the lens.

[0070] After the optical power of the lens is altered, the lens must be stabilized to prevent further undesired changes. Previous lenses which include free monomer(s) typically used partial polymerization, allowed the free monomer(s) to diffuse, then did a complete polymerization to preclude any further change in the shape of the lens or the refractive index. The present disclosure contemplates at least three methods of stabilization.

[0071] First, a UV radiation absorbing layer may be laid over at least one surface of the lens. The UV radiation absorbing layer ideally almost completely absorbs short wavelength photons at low UV intensity, but passes most photons at high UV intensity. An exemplary lens is shown in **FIG. 10**. Here, the lens **200** comprises a polymer matrix **210** and UV radiation absorbing layers **220**, **230** on each surface **212**, **214** of the polymer matrix. An idealized transmission spectrum at the bleaching wavelength and longer is shown in **FIG. 11**. At wavelengths shorter than the bleaching wavelength, the UV absorption layer completely absorbs photons. At the bleaching wavelength and longer, however, the photon absorption depends on the incident flux. At low levels of incident UV intensity, i.e. that of natural illumination, the transmitted flux (i.e. the number of photons passing through the UV absorption layer) is low or zero. At higher levels of incident UV intensity, however, i.e. applied illumination, the transmitted flux increases. This difference allows the lens to be adjusted after implantation by the

application of artificial radiation, then prevent further adjustment during natural use. This UV absorbing layer can be used with both types of intraocular lenses described above.

[0072] The second stabilization method involves crosslinking the chromophore to the polymer matrix, through for example the 2' position. The chromophore can be attached to the polymer matrix as a pendant group or sidechain with a reactive site or group on the chromophore, and a corresponding reaction site or group elsewhere on the polymer matrix. After fabrication, the lens can be stored at a temperature below the T_g of the polymer, greatly slowing the crosslinking reaction. After implantation, the chromophore will slowly crosslink with the polymer matrix, greatly enhancing its photostability. The rate of this crosslinking reaction can be controlled by altering the functionality of the reactive groups, allowing sufficient time for the lens to be adjusted. If the crosslinking occurs through a condensation reaction, water will be the only by-product. After crosslinking, there will be a further reduction in the rate at which the isomerization can occur, further enhancing photostability.

[0073] Crosslinking the chromophore through its 2' position is significant because of the degradation mechanism of, for example, stilbene chromophores. The primary degradation pathway of stilbene chromophores is through oxidation of the central double bond after a trans-cis isomerization. Thus, blocking groups have also shown an increase in the chromophore stability. As shown in the following diagram, the unsubstituted stilbene can undergo trans-cis isomerization, while the substituted stilbene is sterically hindered. By hindering isomerization, stability is increased.

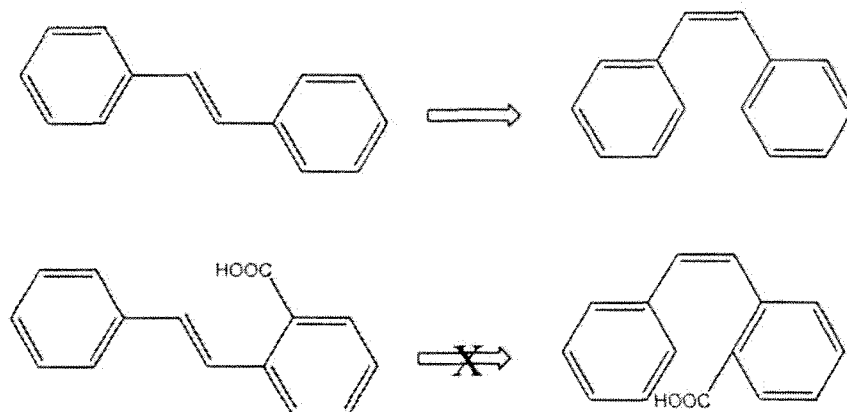

[0074] Finally, the third stabilization method uses a chromophore which bleaches under specific conditions. In particular, a chromophore which requires the absorption of more than one photon to bleach is used. The bleaching process is slow under low-level illumination, but may still occur, particularly during daytime outside exposure. However, judicious selection of the excitation wavelengths of the chromophore can slow this process even further. Referring back to **FIG. 7**, certain wavelengths are filtered from the solar spectrum, due to the presence of specific compounds in the atmosphere. Design of the chromophore so that one of the two wavelengths needed to cause bleaching corresponds to one of the filtered wavelengths will lead to a lens with enhanced stability, as there will be no high-intensity natural radiation at that wavelength to initiate the photodegradation.

[0075] For example, if we assume a chromophore with an absorption maximum of 400 nm, the two-photon absorption would then occur at about 340 nm. If one of the wavelengths is 1300 nm (which is strongly absorbed in the atmosphere), we can calculate that the other wavelength needed would be 460 nm. Thus a combination of a 1300 nm photon and a 460 nm photon could be absorbed, even though neither photon will be absorbed individually. Because the 1300 nm photon is not strongly present in natural outdoor illumination, absorption and continued photobleaching would not occur.

[0076] The photostability of chromophores may also be enhanced in other ways. The chromophores may be attached to the polymer matrix as a polymer side chain or pendant group. Chromophores could be crosslinked to other functional groups on the polymer backbone or sidechains, reducing the conformational movement often needed as part of the photobleaching process. The absorption maximum wavelength could be blue-shifted. The functional groups of the chromophore could be changed to inhibit rotational motion around specific bonds, or block specific photodegradation pathways. For example, inclusion of a trifluoromethyl group at the 2 or 2' position of an azobenzene chromophore can reduce the rate at which photobleaching occurs. Finally, the local environment of the chromophore could be changed, e.g. by changing the local pH.

[0077] Aspects of the present disclosure may be further understood by referring to the following examples. The examples are merely for further describing various aspects

of the devices and methods of the present disclosure and are not intended to be limiting embodiments thereof.

EXAMPLES

[0078] Experimental measurements were performed to verify that the refractive index changed upon crosslinking and without the presence of free monomer. The experiments also showed that the refractive index change was controllable, reproducible, and adjustable.

[0079] A series of experiments were also performed to verify the amount of change in the refractive index possible with photobleaching, and also that photobleaching could occur in an aqueous environment.

EXAMPLE 1

[0080] A solution of 37.5% SARTOMER CN990, 59.4% SARTOMER SR344 and 3.1% DAROCUR 4265 was created (composition was based on weight fraction of the components). SARTOMER CN990 is a siliconized urethane acrylate oligomer. SARTOMER SR344 is a polyethylene glycol diacrylate having a molecular weight of 508. DAROCUR 4265 is a photoinitiator mixture of 50 weight percent diphenyl (2,4,6-trimethylbenzoyl) phosphine oxide and 50 weight percent 2-hydroxy-2-methyl-1-phenyl-1-propanone. DAROCUR 4265 has absorption peaks at 240, 272, and 380 nm in methanol.

[0081] The refractive index of the solution was measured to be 1.4717. The solution was then cast onto a slide and exposed to 10 seconds of UV light from a lamp source. The refractive index of the film was then measured using a Metricon Model 2010 Prism Coupler, and was determined to be 1.4747. Additional UV exposure of 5 seconds gave a refractive index of $n=1.4852$. Further UV exposure of 15 seconds gave a refractive index of $n=1.4868$. In other words, as the amount of UV exposure increased, the amount of crosslinking increased and thus the refractive index increased.

EXAMPLE 2

[0082] The solution of Example 1 was again created, except the DAROCUR 4265 was replaced with IRGACURE 2959, which is sensitive to 254 nm UV. The solution was cast onto a plate and exposed to UV light. After 2 seconds exposure, the refractive index was measured with the prism coupler and found to be $n=1.4668$, with the film not being fully cured in the center. An additional 5 second UV exposure led to the refractive index being measured as $n=1.485$.

EXAMPLE 3

[0083] A third experiment was performed to better evaluate the exposure-dependence of the refractive index. A solution similar to that of Example 1 was prepared and cast onto a slide. The film then underwent several cycles of UV exposure and refractive index measurement. The results are shown in **FIG. 12**. Below 8 seconds exposure, the film was not fully set. The data is also summarized in Table 1.

Table 1.

Time (sec)	Refractive Index
8	1.4799
10	1.4804
15	1.4835
20	1.4887
25	1.489

[0084] The results indicated that the refractive index could be changed by a range of about 0.01 after exposure of about 25 seconds. This value of index change was selected as providing approximately a 10% change in lens power (as shown in **FIG. 2**).

EXAMPLE 4

[0085] A solution of VC60 in polymethylmethacrylate (PMMA) was cast as a film and dried at 80°C for 10 minutes. The refractive index of the film was 1.4909. The film was then exposed to 254 nm radiation for 1 minute. The refractive index was then measured to be 1.5016. After further exposure (30 minutes total) the refractive index was 1.5036.

Absorbance measurements showed ~50% decrease in absorbance due to the chromophore.

EXAMPLE 5

[0086] A solution of EC24 in PMMA was cast as a film and dried at 80°C for 10 minutes. The refractive index of the film was measured as $n=1.5014$. The film was then exposed to 254 nm radiation for 30 minutes. The refractive index was then measured as $n=1.4924$.

EXAMPLE 6

[0087] EC24 was then diffused into an ACUVUE lens (Johnson & Johnson Vision Care, Inc.). The lens was partially masked, then exposed to 254 nm UV light for 30 minutes. The chromophore bleached, but over time the demarcation line between the masked and unmasked portions of the lens blurred. This may be attributable to migration of the chromophore in the lens.

[0088] The experiment was then repeated by diffusing EC24 into two separate ACUVUE lenses. The first lens was kept as a control, and exhibited very uniform red color, consistent with an absorption maximum near 510 nm for EC24 in the lens. The second lens was exposed to the UV light for 30 minutes. At the end of this exposure, the second lens exhibited no color and was completely transparent.

EXAMPLE 7

[0089] The transmission spectra of an ACUVUE lens was measured. EC24 was then diffused into the lens, and the transmission spectrum was measured again. Finally, the lens was bleached and the transmission spectrum was measured a third time. The results are shown in **FIG. 13** and Table 2.

Table 2.

Wavelength (nm)	%T hydrated lens	%T EC24 doped lens	%T bleached lens
350	10.3	4.5	21
360	10.7	11.7	19.4
370	28.4	30.1	36.4
380	63.9	52.6	60.9
390	82.5	62	72.1
400	87	64	72.8
410	87.9	64.4	75.9
420	88.3	64.5	76.4
430	88.4	64.5	76.7
440	88.8	64.2	77.2
450	88.8	64.1	77.6
460	89	63.5	77.6
470	89	62.6	77.8
480	89.1	61.9	78.7
490	89.2	61.3	80
500	89.1	60.6	81.2
510	88.9	60.3	81.6
520	88.8	60.6	82.2
530	88.8	61.1	82.7
540	88.9	62.4	83.5
550	88.9	64.1	83.9
560	88.9	66.2	84.5
570	88.9	67.8	84.9
580	88.9	69.3	85.5
590	88.8	70	86
600	89	70.6	86.6

[0090] Note that the EC24 doped lens shows a transmission minimum close to 510 nm, while the absorption maximum of EC24 in dioxane was measured to be 503 nm. This indicates that the EC24 is present in the doped lens. The photobleached lens has weaker absorption and no longer has the absorption at 510 nm, indicating that the photobleaching process has altered the chemistry of EC24.

[0091] The devices and methods of the present disclosure have been described with reference to exemplary embodiments. Obviously, modifications and alterations will occur to others upon reading and understanding the preceding detailed description. It is intended that the exemplary embodiments be construed as including all such

modifications and alterations insofar as they come within the scope of the appended claims or the equivalents thereof.

CLAIMS:

1. An intraocular lens comprising:
a single polymer matrix having crosslinkable pendant groups, wherein the polymer matrix increases in volume when crosslinked; and
wherein substantially no free monomers are present therein.
2. The lens of claim 1, further comprising a UV absorbing layer on at least one surface of the lens.
3. The lens of claim 1, wherein the pendant group is 3,9-divinyl-2,4,8,10-tetraoxy-spiro[5.5]undecane.
4. An intraocular lens comprising a polymer matrix including photobleachable chromophores.
5. The lens of claim 4, further comprising a UV absorbing layer on at least one surface of the lens.
6. The lens of claim 4, wherein the photobleachable chromophores are dispersed within the polymer matrix.
7. The lens of claim 4, wherein the photobleachable chromophores are present as pendant groups on the polymer matrix.
8. The lens of claim 4, wherein at least one chromophore comprises a reactive site which can crosslink with a reactive site on the polymer matrix.
9. The lens of claim 4, wherein the photobleachable chromophores comprise a malononitrile moiety.

10. The lens of claim 4, wherein the photobleachable chromophores comprise chromophores of Formula (I) or Formula (II):

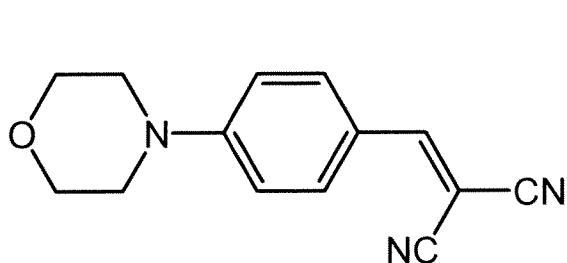

Formula (I)

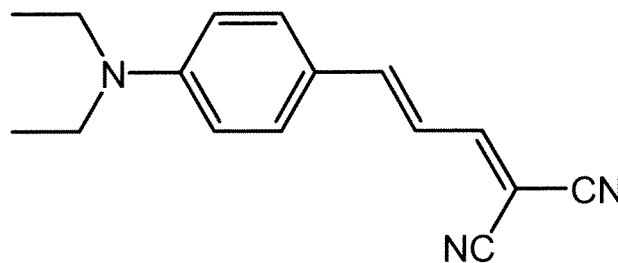

Formula (II)

11. The lens of claim 4, wherein the photobleachable chromophores comprise stilbene chromophores of Formula (III):

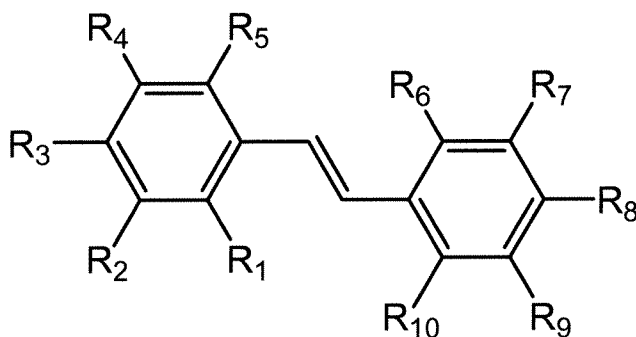

Formula (III)

where R₁-R₁₀ are independently selected from hydrogen, alkyl, substituted alkyl, aryl, substituted aryl, -COOH, and -NO₂.

12. The lens of claim 4, wherein the photobleachable chromophores comprise azobenzene chromophores of Formula (IV):

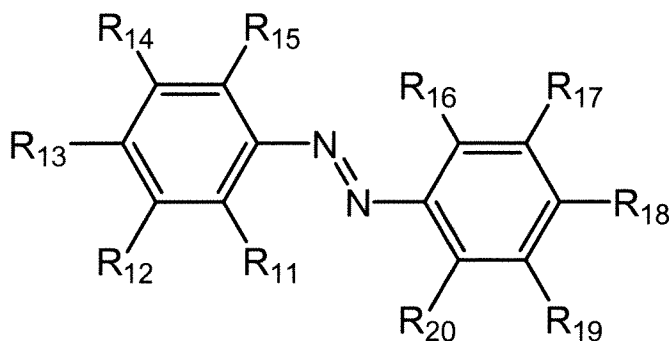

Formula (IV)

where R_{10} - R_{20} are independently selected from hydrogen, alkyl, substituted alkyl, aryl, substituted aryl, -COOH, -NO₂, halogen, amino, and substituted amino.

13. The lens of claim 4, wherein at least one chromophore must absorb more than one photon for photobleaching of the chromophore to occur.

14. A method of altering the optical power of a lens, comprising:
 providing a lens comprising:
 a single polymer matrix having crosslinkable pendant groups,
 wherein the polymer matrix increases in volume when crosslinked;
 and
 wherein the lens is devoid of free monomers; and
 exposing a portion of the lens to radiation, causing crosslinking to occur in the exposed portion of the lens and increasing the refractive index of the exposed portion of the lens, thereby altering the optical power of the lens.

15. The method of claim 14, wherein the exposed portion of the lens is in the center of the lens.

16. The method of claim 14, wherein the radiation to which the lens is exposed has a wavelength of from about 200 nm to about 600 nm.

17. A method of altering the optical power of a lens, comprising:
providing a lens comprising a polymer matrix having photobleachable chromophores; and

exposing a portion of the lens to radiation, causing photobleaching to occur in the exposed portion of the lens and decreasing the refractive index of the exposed portion of the lens, thereby altering the optical power of the lens.

18. The method of claim 17, wherein the exposed portion of the lens is in the center of the lens.

19. The method of claim 17, wherein the radiation to which the lens is exposed has a wavelength of from about 200 nm to about 600 nm.

20. The method of claim 17, wherein the photobleachable chromophores are dispersed within the polymer matrix.

21. The method of claim 17, wherein the photobleachable chromophores are present as pendant groups on the polymer matrix.

22. The method of claim 17, wherein at least one chromophore comprises a reactive site which can crosslink with a reactive site on the polymer matrix.

23. The method of claim 17, wherein the photobleachable chromophores comprise a malononitrile moiety.

24. The method of claim 17, wherein the photobleachable chromophores comprise chromophores of Formula (I) or Formula (II):

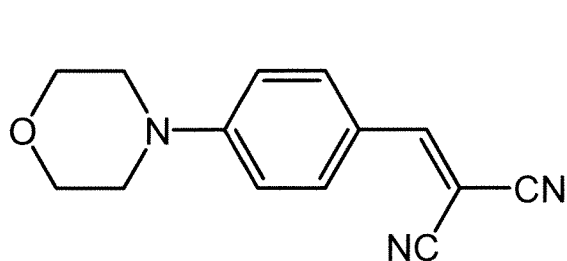

Formula (I)

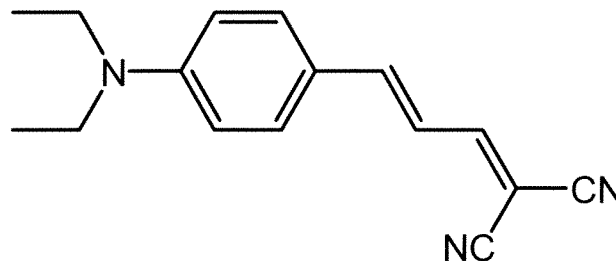

Formula (II).

25. The method of claim 17, wherein the photobleachable chromophores comprise stilbene chromophores of Formula (III):

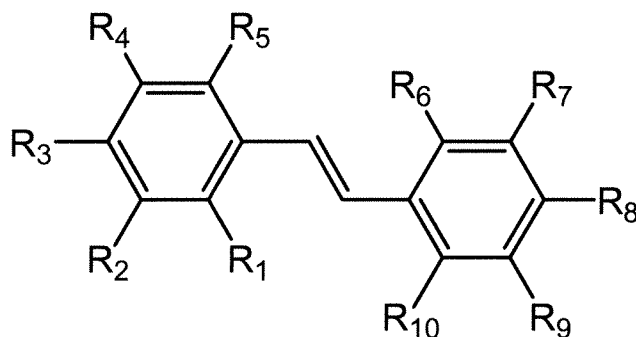

Formula (III)

where R_1 - R_{10} are independently selected from hydrogen, alkyl, substituted alkyl, aryl, substituted aryl, $-COOH$, and $-NO_2$.

26. The method of claim 17, wherein the photobleachable chromophores comprise azobenzene chromophores of Formula (IV):

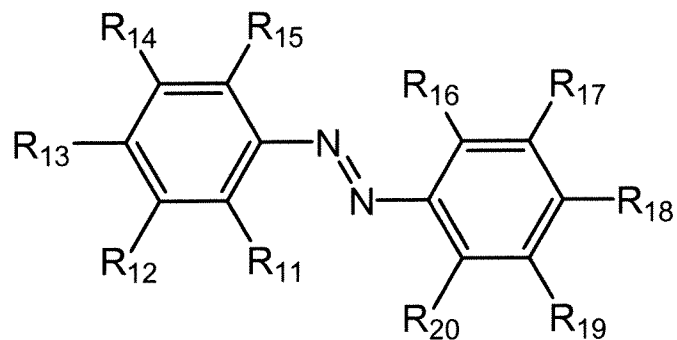

Formula (IV)

where R₁₀-R₂₀ are independently selected from hydrogen, alkyl, substituted alkyl, aryl, substituted aryl, -COOH, -NO₂, halogen, amino, and substituted amino.

27. The method of claim 17, wherein at least one chromophore must absorb more than one photon for photobleaching of the chromophore to occur.

AMENDED CLAIMS**received by the International Bureau on 12 September 2009 (12.09.2009)**

1. An intraocular lens comprising:
a single polymer matrix having crosslinkable pendant groups, wherein the polymer matrix increases in volume when crosslinked; and
wherein substantially no free monomers are present therein.
2. The lens of claim 1, further comprising a UV absorbing layer on at least one surface of the lens.
3. The lens of claim 1, wherein the pendant group is 3,9-divinyl-2,4,8,10-tetraoxy-spiro[5.5]undecane.
4. An intraocular lens comprising a polymer matrix including photobleachable chromophores, wherein the lens is devoid of free monomer.
5. The lens of claim 4, further comprising a UV absorbing layer on at least one surface of the lens.
6. The lens of claim 4, wherein the photobleachable chromophores are dispersed within the polymer matrix.
7. The lens of claim 4, wherein the photobleachable chromophores are present as pendant groups on the polymer matrix.
8. The lens of claim 4, wherein at least one chromophore comprises a reactive site which can crosslink with a reactive site on the polymer matrix.
9. The lens of claim 4, wherein the photobleachable chromophores comprise a malononitrile moiety.

10. The lens of claim 4, wherein the photobleachable chromophores comprise chromophores of Formula (I) or Formula (II):

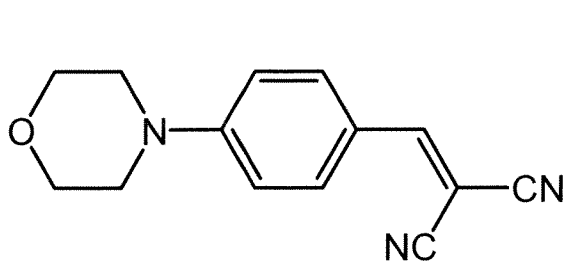

Formula (I)

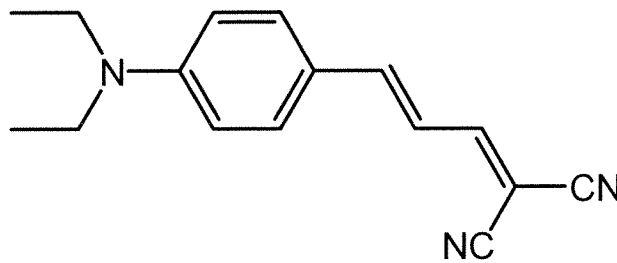

Formula (II).

11. The lens of claim 4, wherein the photobleachable chromophores comprise stilbene chromophores of Formula (III):

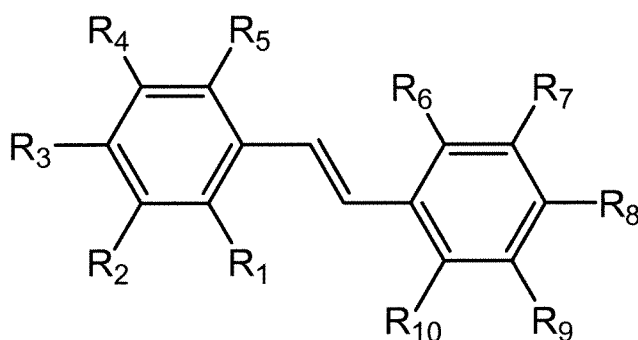

Formula (III)

where R_1 - R_{10} are independently selected from hydrogen, alkyl, substituted alkyl, aryl, substituted aryl, $-COOH$, and $-NO_2$.

12. The lens of claim 4, wherein the photobleachable chromophores comprise azobenzene chromophores of Formula (IV):

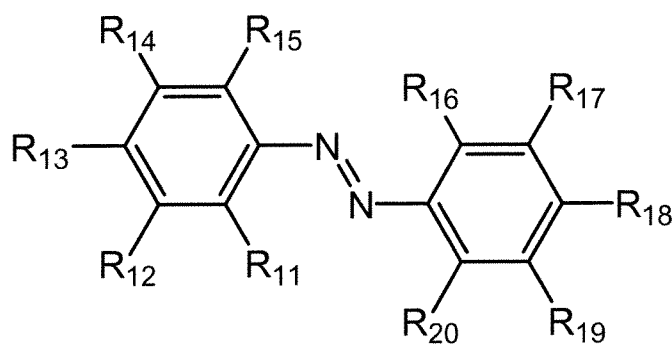

Formula (IV)

where R_{10} - R_{20} are independently selected from hydrogen, alkyl, substituted alkyl, aryl, substituted aryl, $-COOH$, $-NO_2$, halogen, amino, and substituted amino.

13. The lens of claim 4, wherein at least one chromophore must absorb more than one photon for photobleaching of the chromophore to occur.

14. A method of altering the optical power of a lens, comprising:
 providing a lens comprising:
 a single polymer matrix having crosslinkable pendant groups,
 wherein the polymer matrix increases in volume when crosslinked;
 and
 wherein the lens is devoid of free monomers; and
 exposing a portion of the lens to radiation, causing crosslinking to occur in the exposed portion of the lens and increasing the refractive index of the exposed portion of the lens, thereby altering the optical power of the lens.

15. The method of claim 14, wherein the exposed portion of the lens is in the center of the lens.

16. The method of claim 14, wherein the radiation to which the lens is exposed has a wavelength of from about 200 nm to about 600 nm.

17. A method of altering the optical power of a lens, comprising:
providing a lens comprising a polymer matrix having photobleachable chromophores, wherein the lens is devoid of free monomer; and
exposing a portion of the lens to radiation, causing photobleaching to occur in the exposed portion of the lens and decreasing the refractive index of the exposed portion of the lens, thereby altering the optical power of the lens.

18. The method of claim 17, wherein the exposed portion of the lens is in the center of the lens.

19. The method of claim 17, wherein the radiation to which the lens is exposed has a wavelength of from about 200 nm to about 600 nm.

20. The method of claim 17, wherein the photobleachable chromophores are dispersed within the polymer matrix.

21. The method of claim 17, wherein the photobleachable chromophores are present as pendant groups on the polymer matrix.

22. The method of claim 17, wherein at least one chromophore comprises a reactive site which can crosslink with a reactive site on the polymer matrix.

23. The method of claim 17, wherein the photobleachable chromophores comprise a malononitrile moiety.

24. The method of claim 17, wherein the photobleachable chromophores comprise chromophores of Formula (I) or Formula (II):

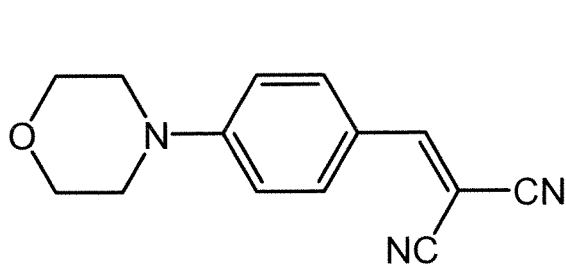

Formula (I)

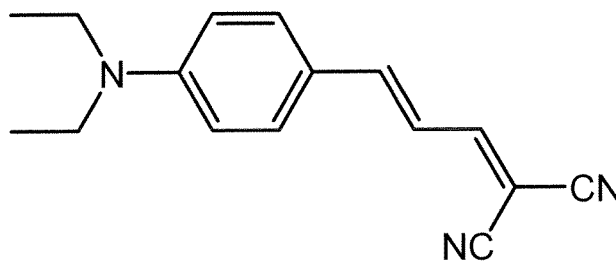

Formula (II).

25. The method of claim 17, wherein the photobleachable chromophores comprise stilbene chromophores of Formula (III):

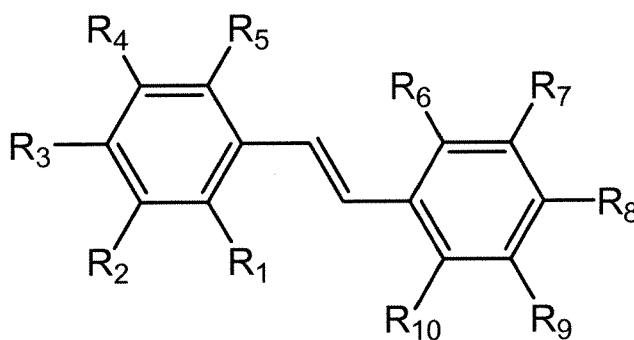

Formula (III)

where R_1 - R_{10} are independently selected from hydrogen, alkyl, substituted alkyl, aryl, substituted aryl, $-COOH$, and $-NO_2$.

26. The method of claim 17, wherein the photobleachable chromophores comprise azobenzene chromophores of Formula (IV):

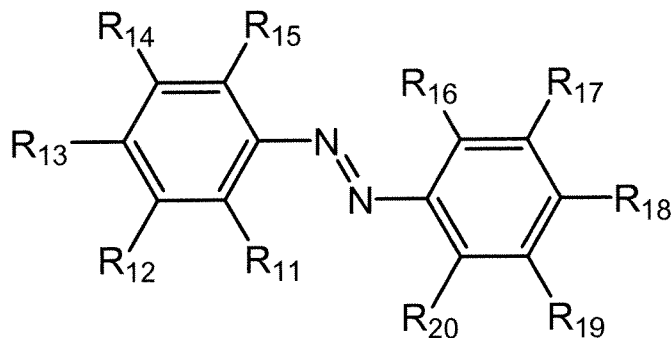

Formula (IV)

where R₁₀-R₂₀ are independently selected from hydrogen, alkyl, substituted alkyl, aryl, substituted aryl, -COOH, -NO₂, halogen, amino, and substituted amino.

27. The method of claim 17, wherein at least one chromophore must absorb more than one photon for photobleaching of the chromophore to occur.

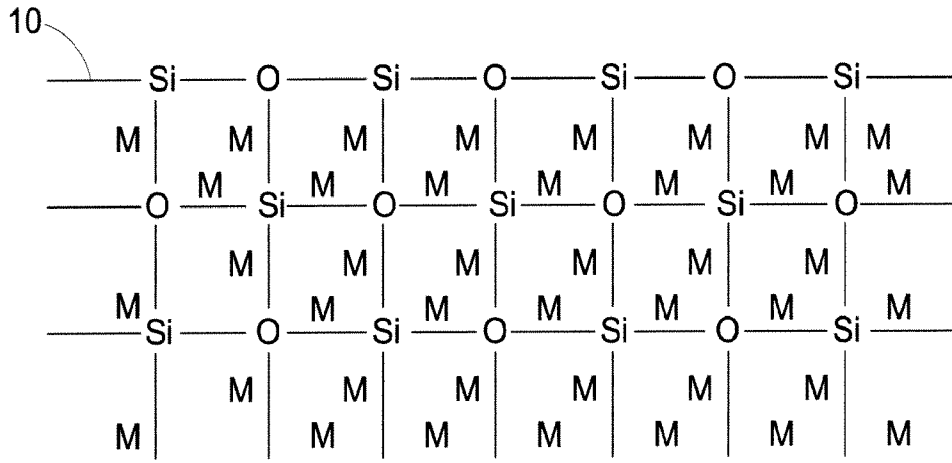

FIG. 1A

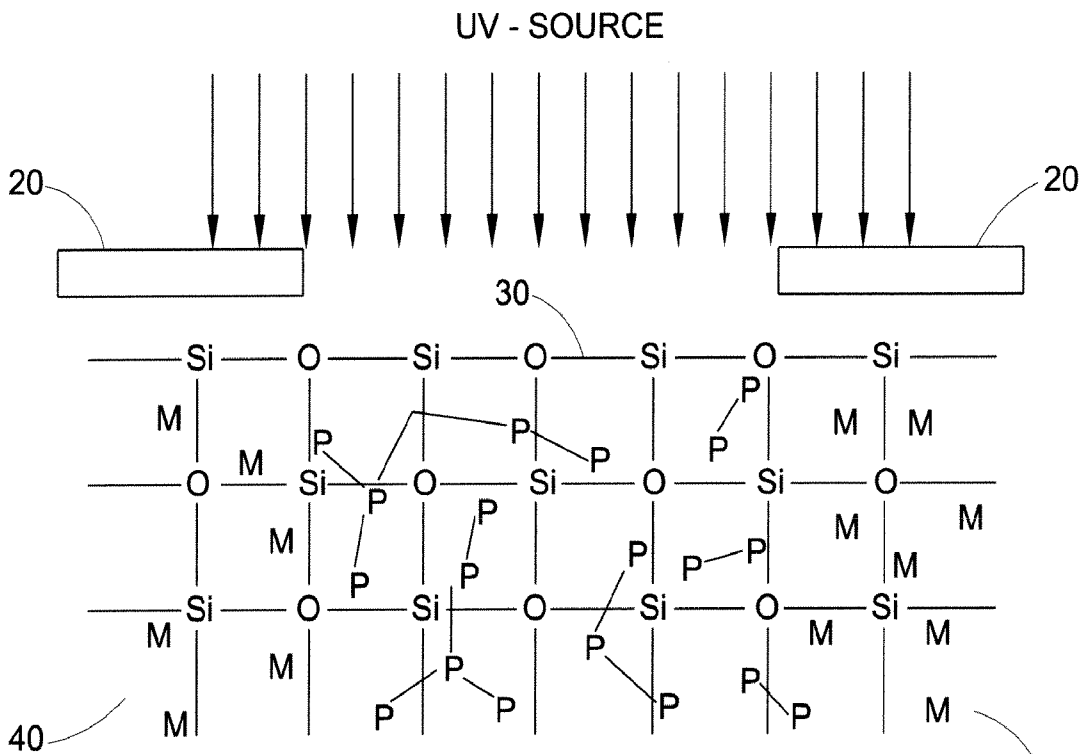

FIG. 1B

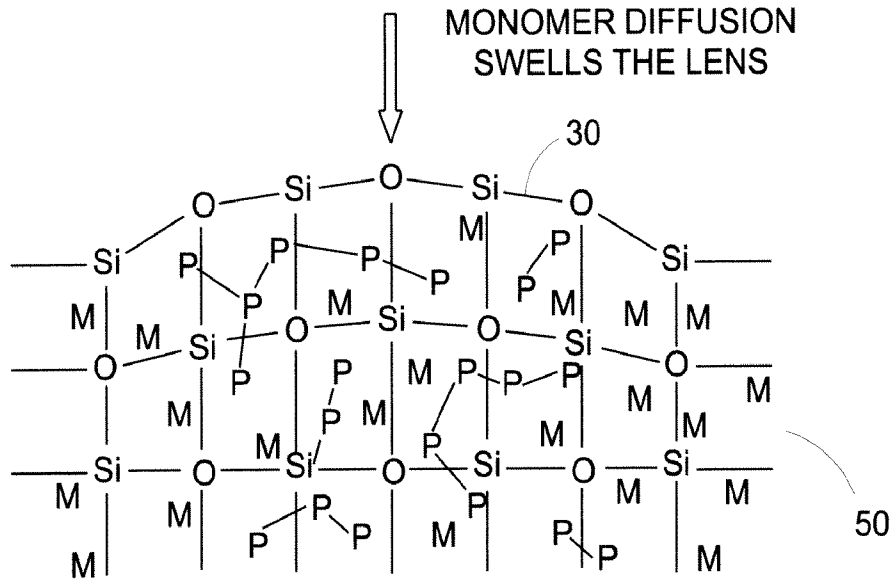

FIG. 1C

UV - SOURCE

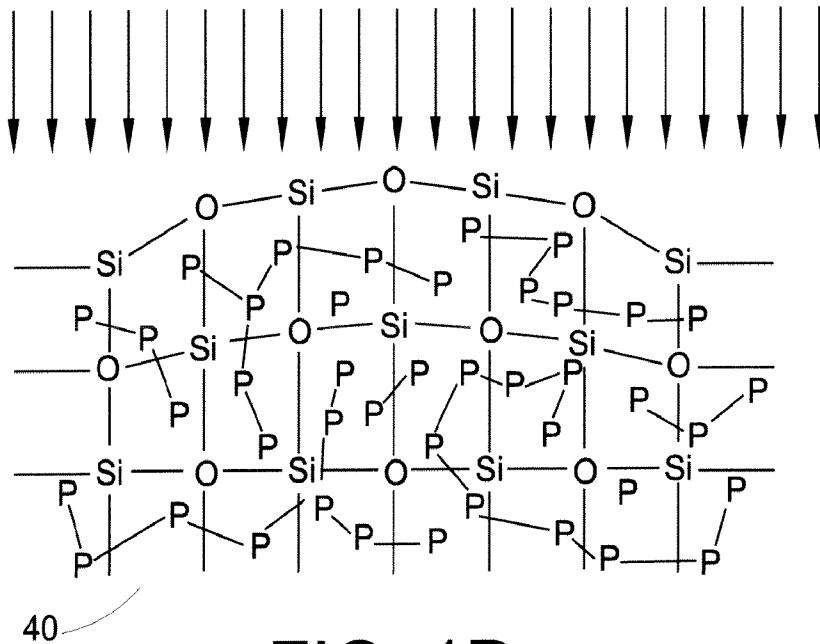
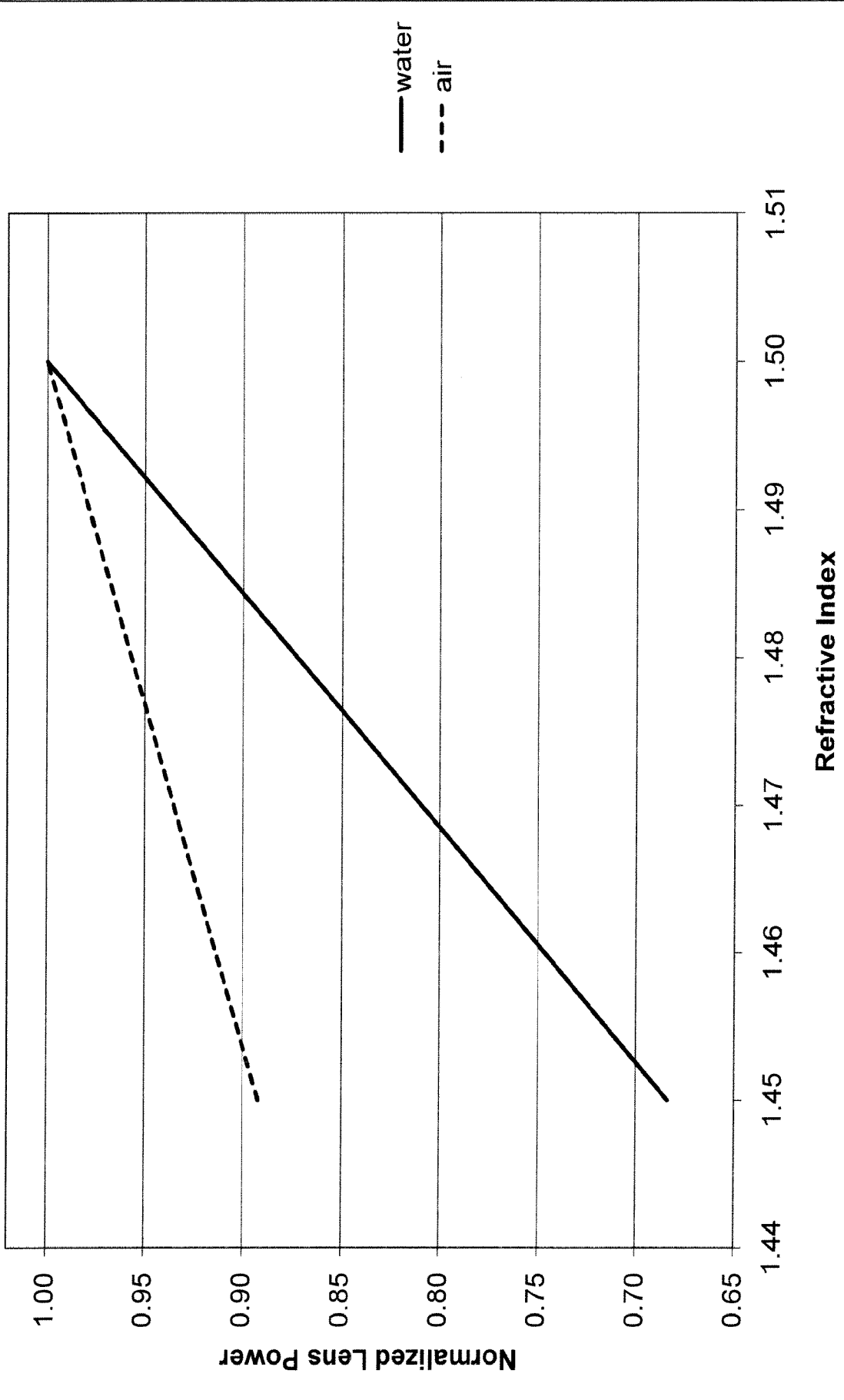

FIG. 1D

FIG. 2.



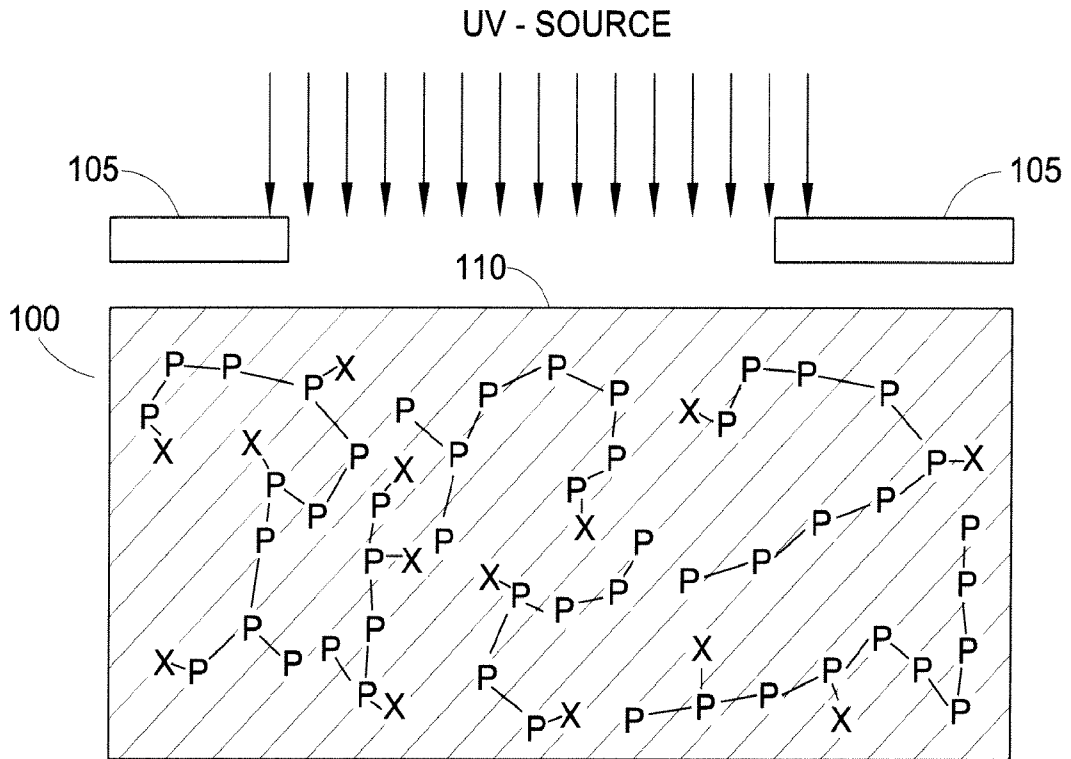

FIG. 3A

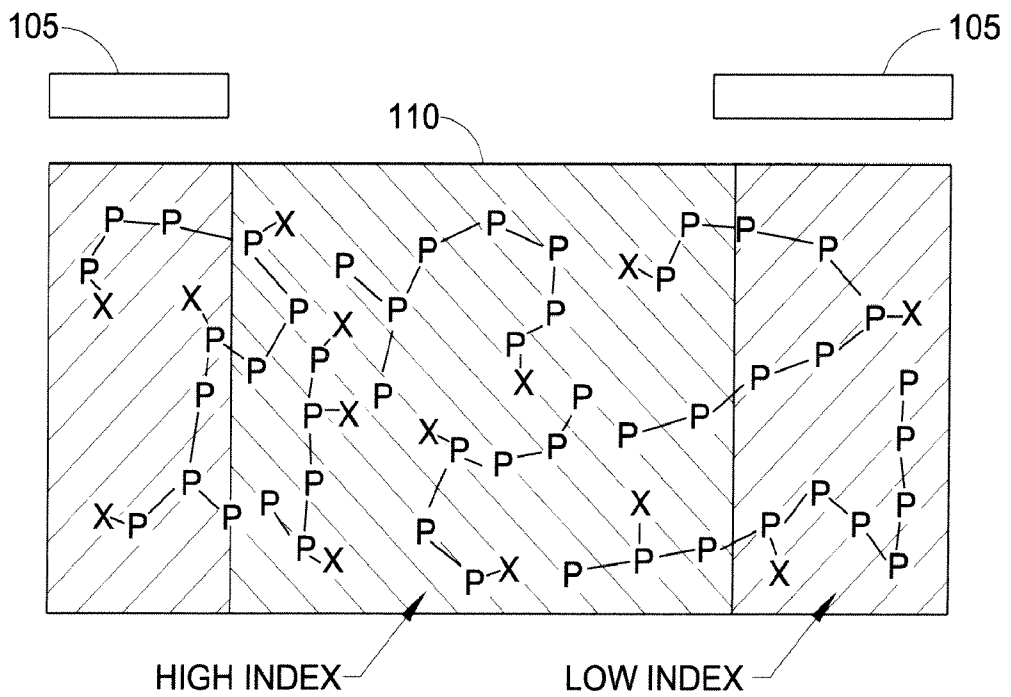

FIG. 3B

FIG. 4.

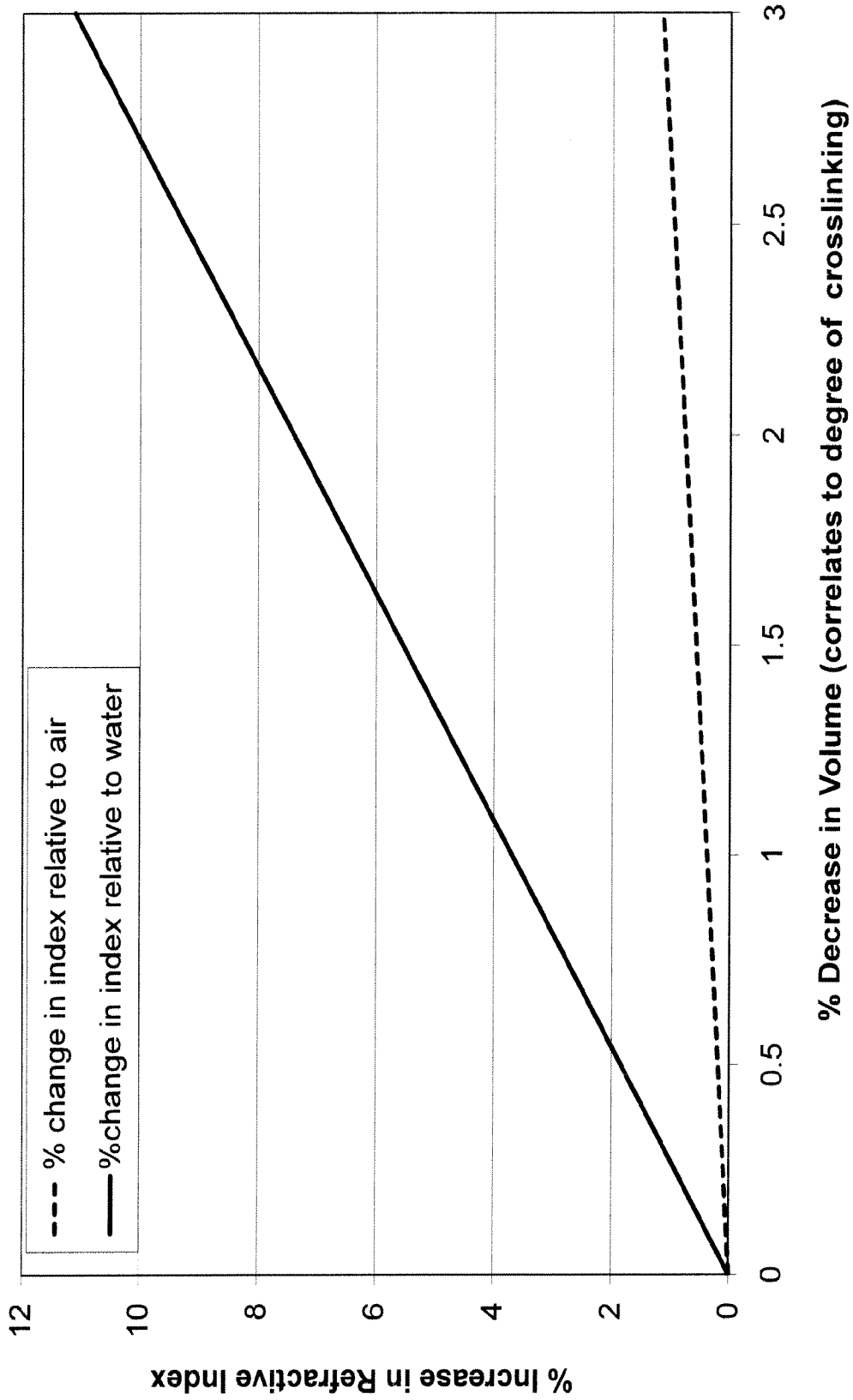
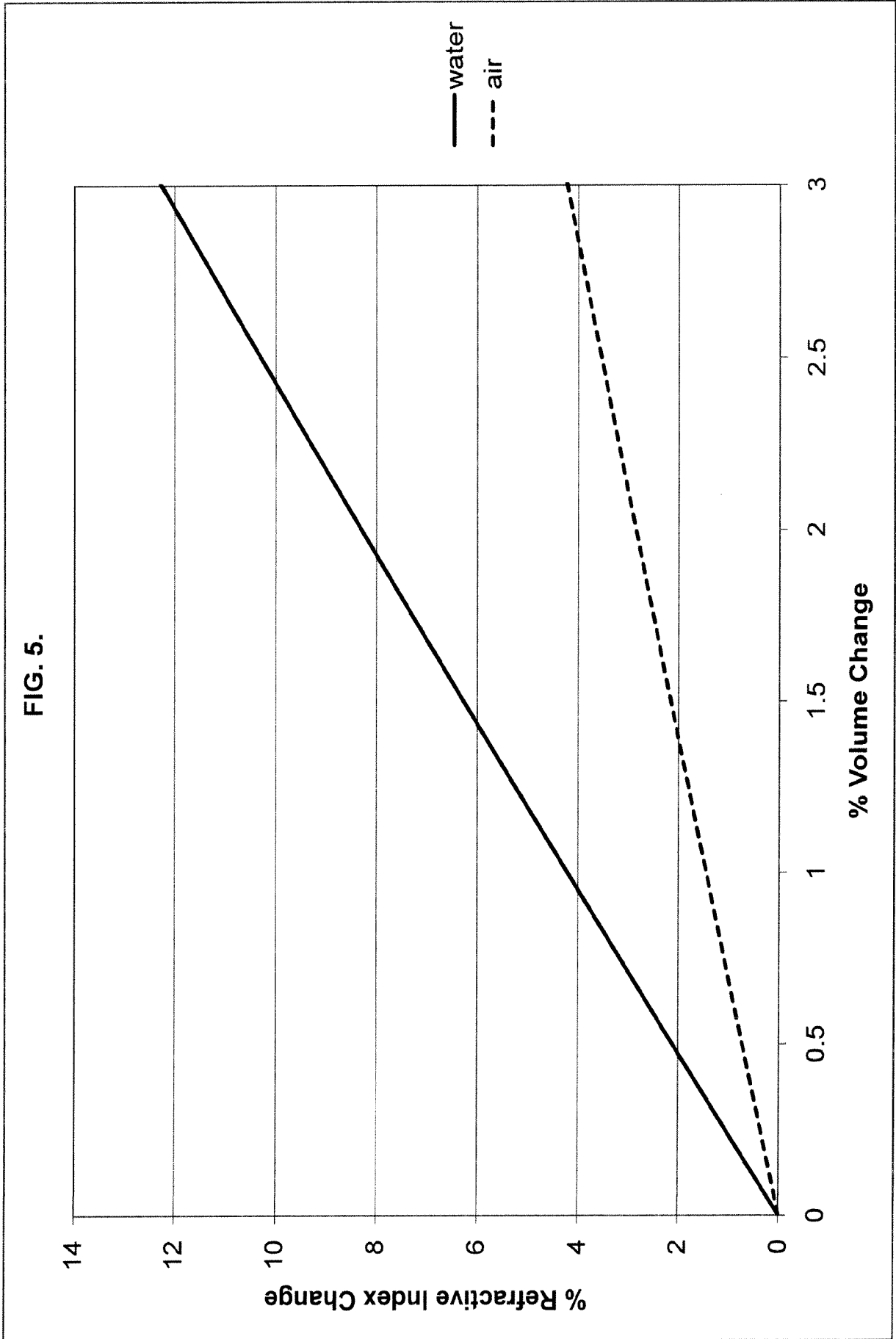
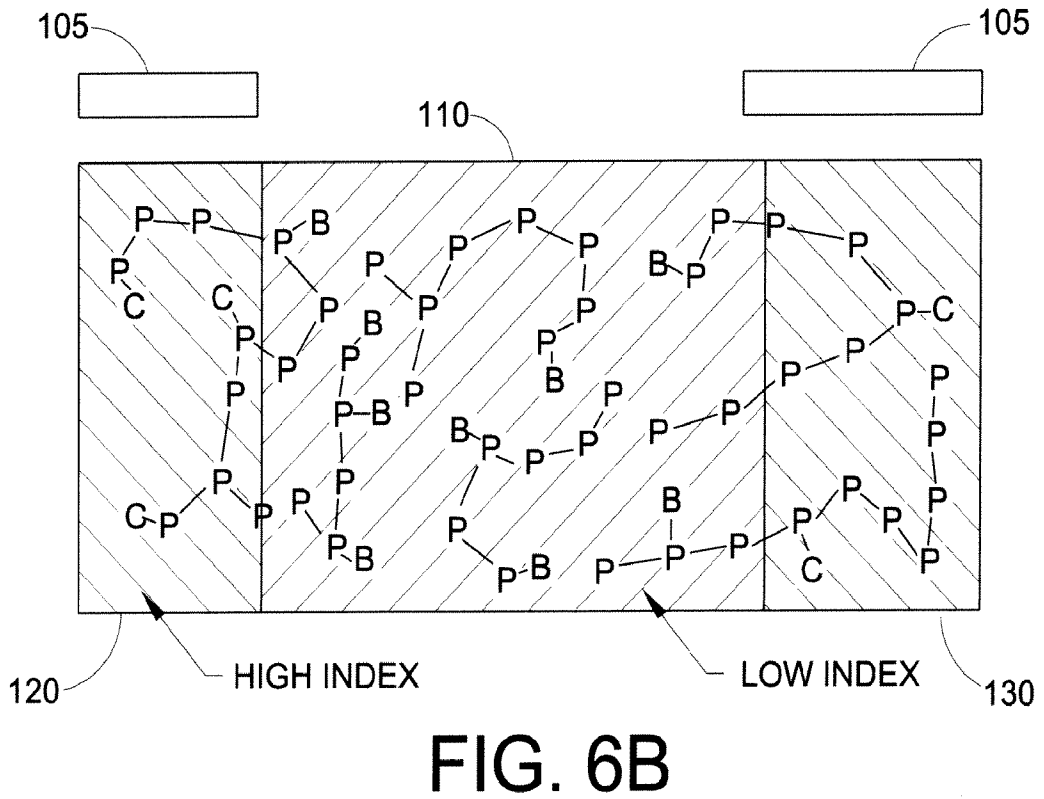
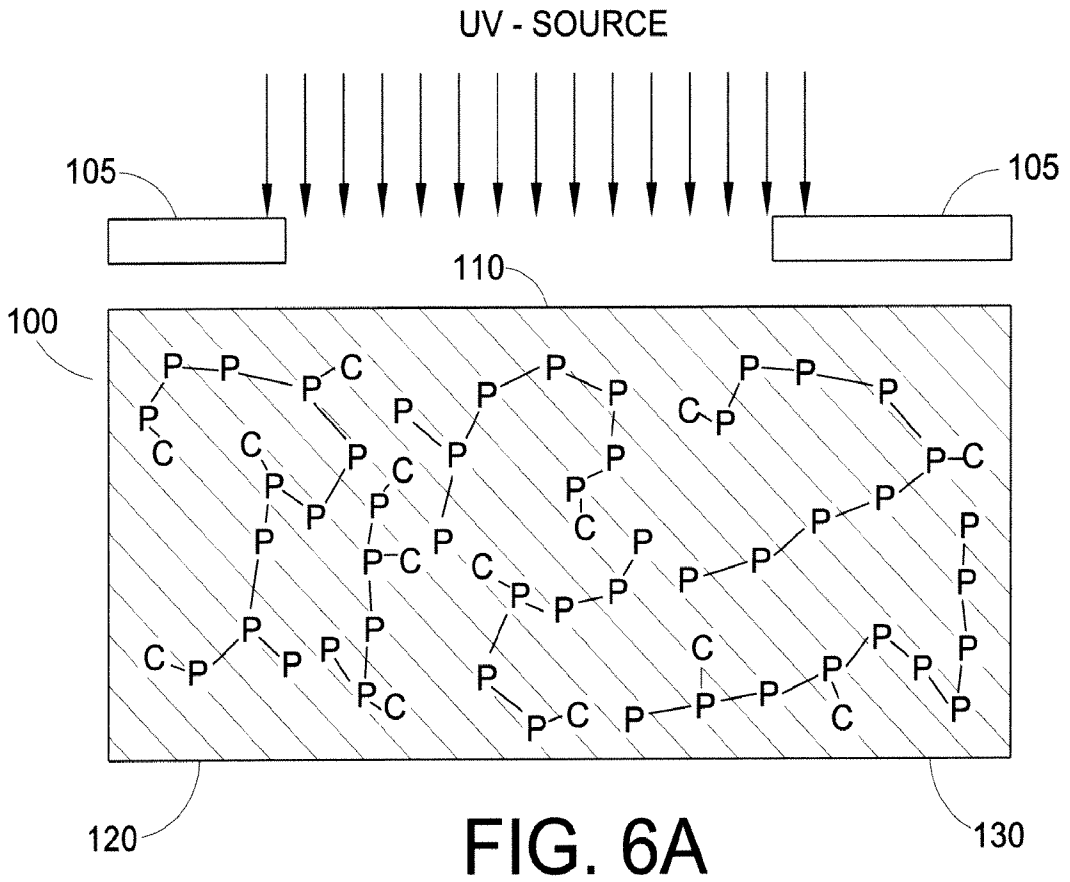

FIG. 5.





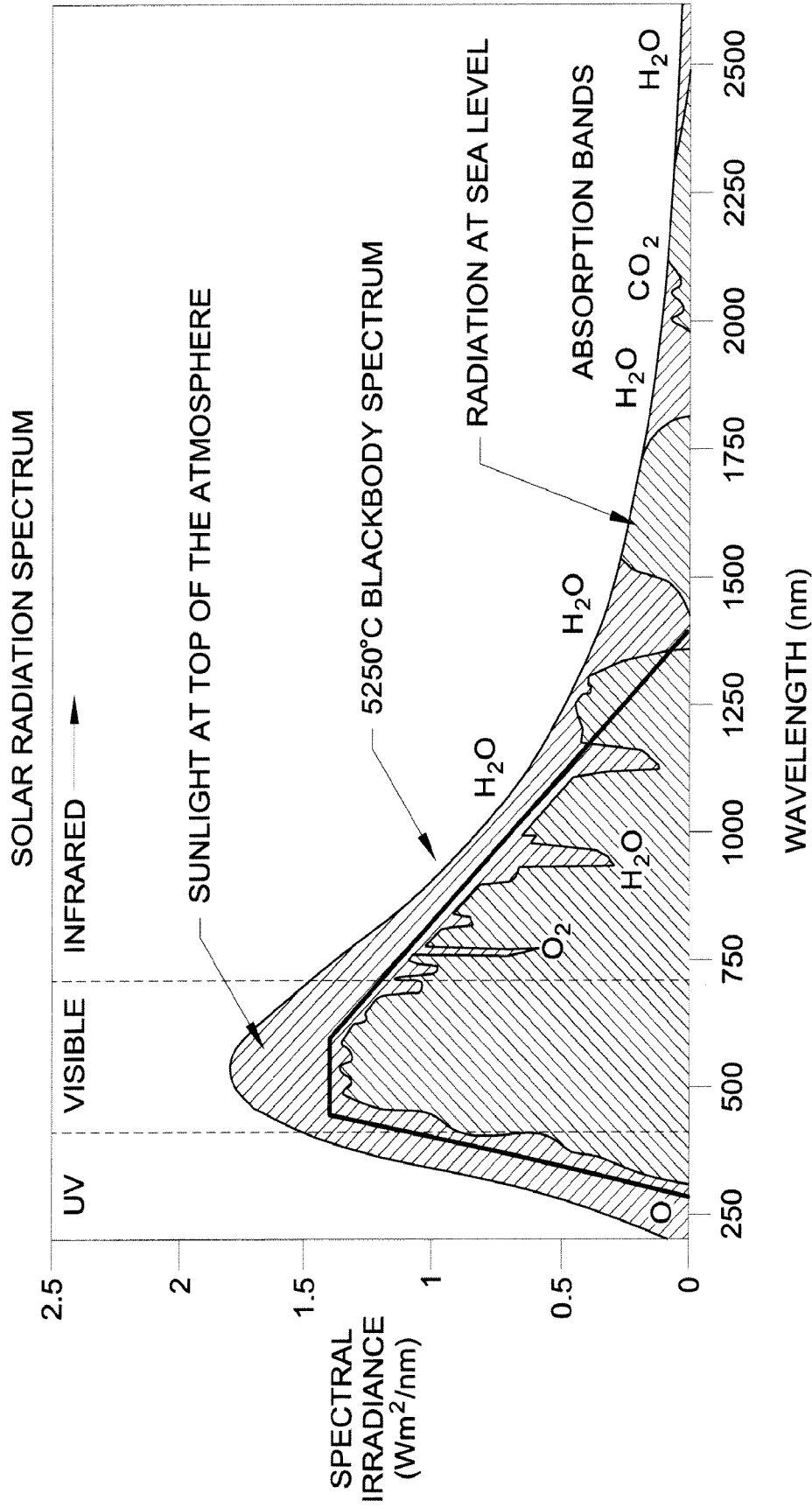
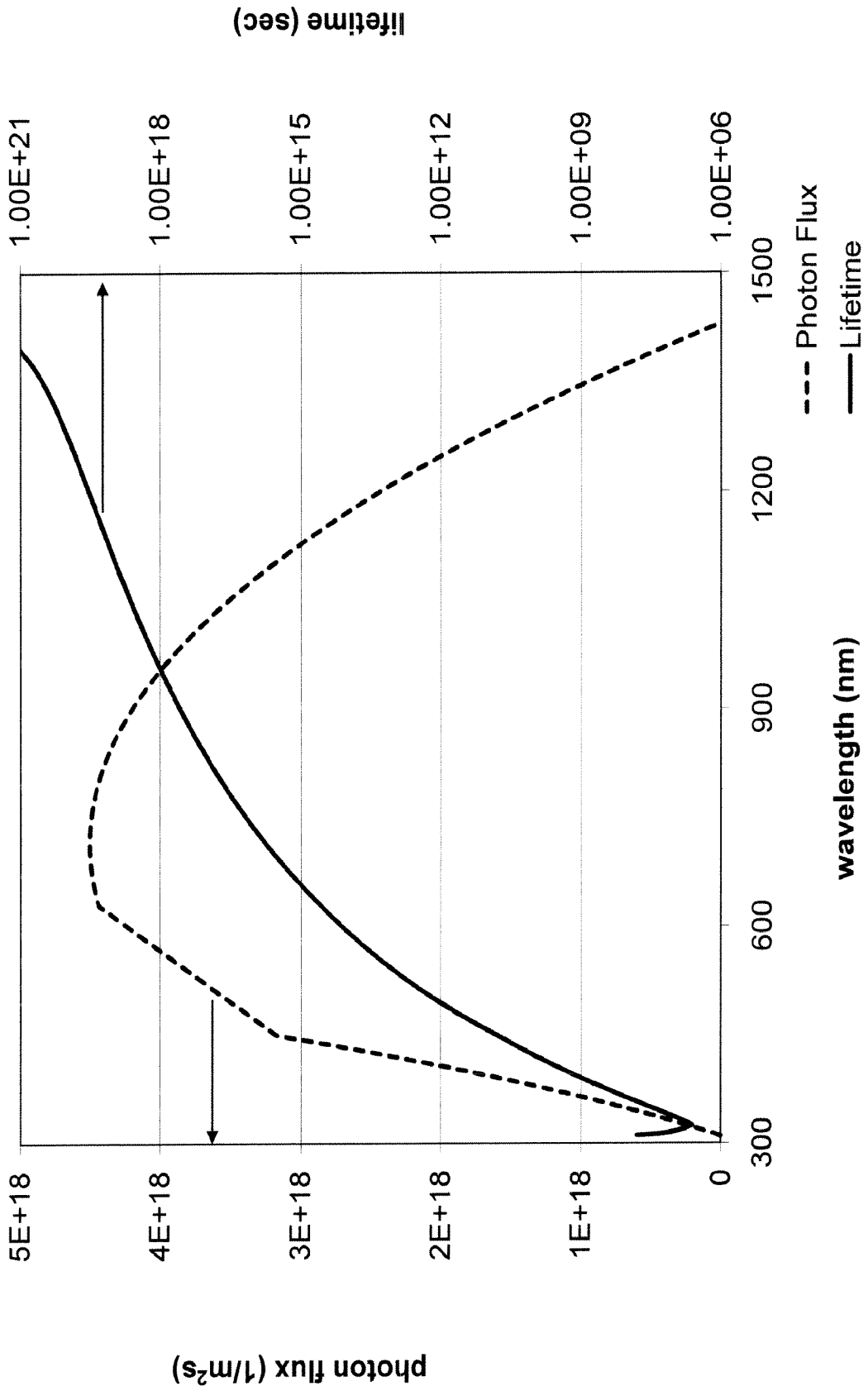

FIG. 7

FIG. 8.



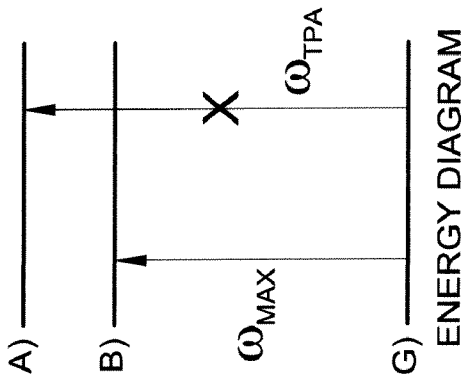

FIG. 9A

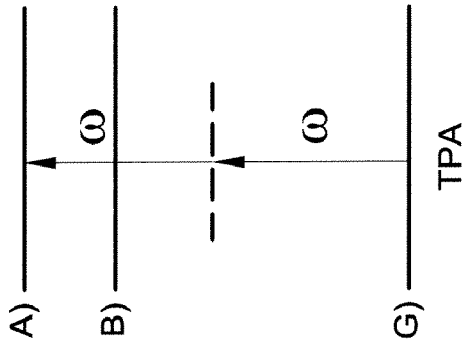

FIG. 9B

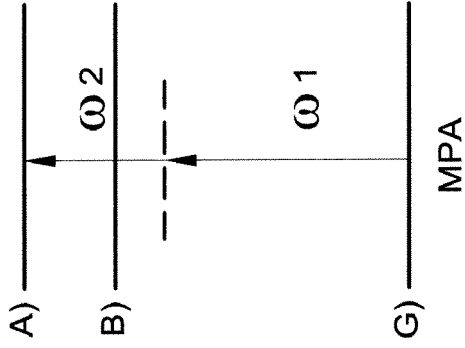

FIG. 9C

200

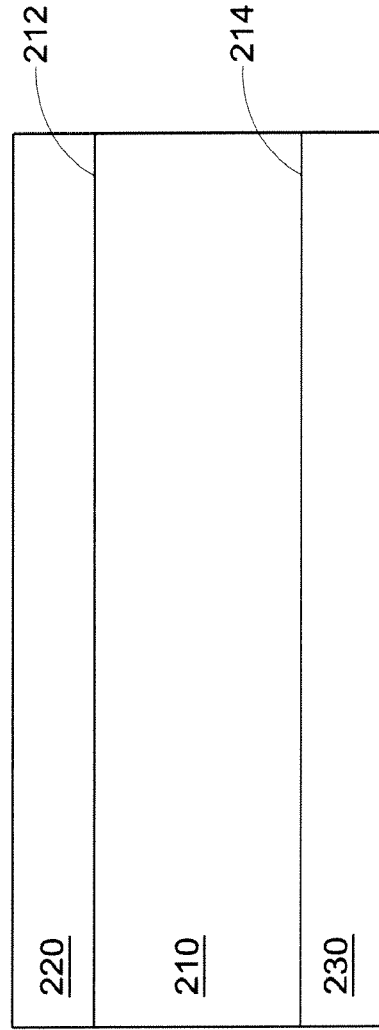

FIG. 10

FIG. 11.

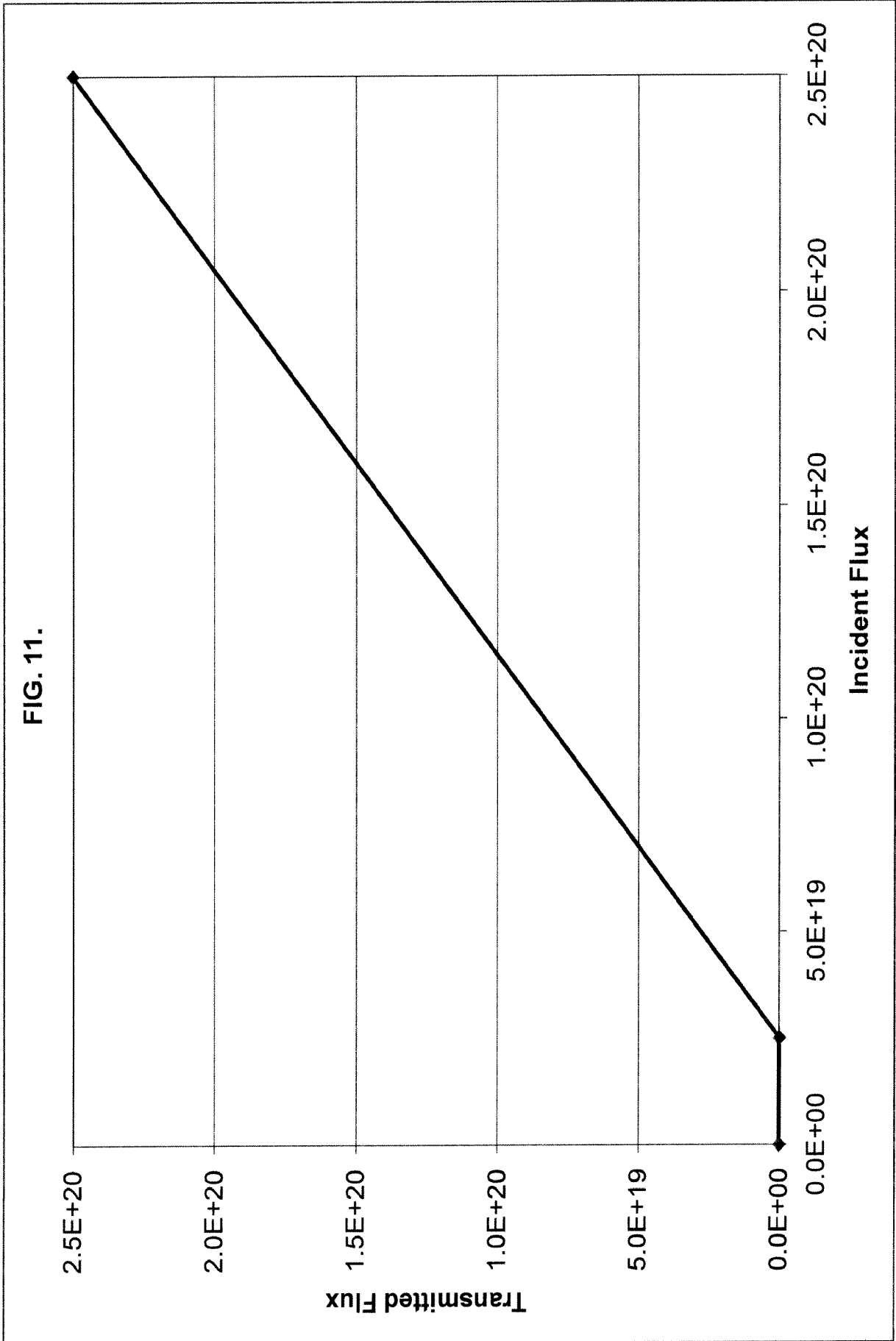

FIG. 12.

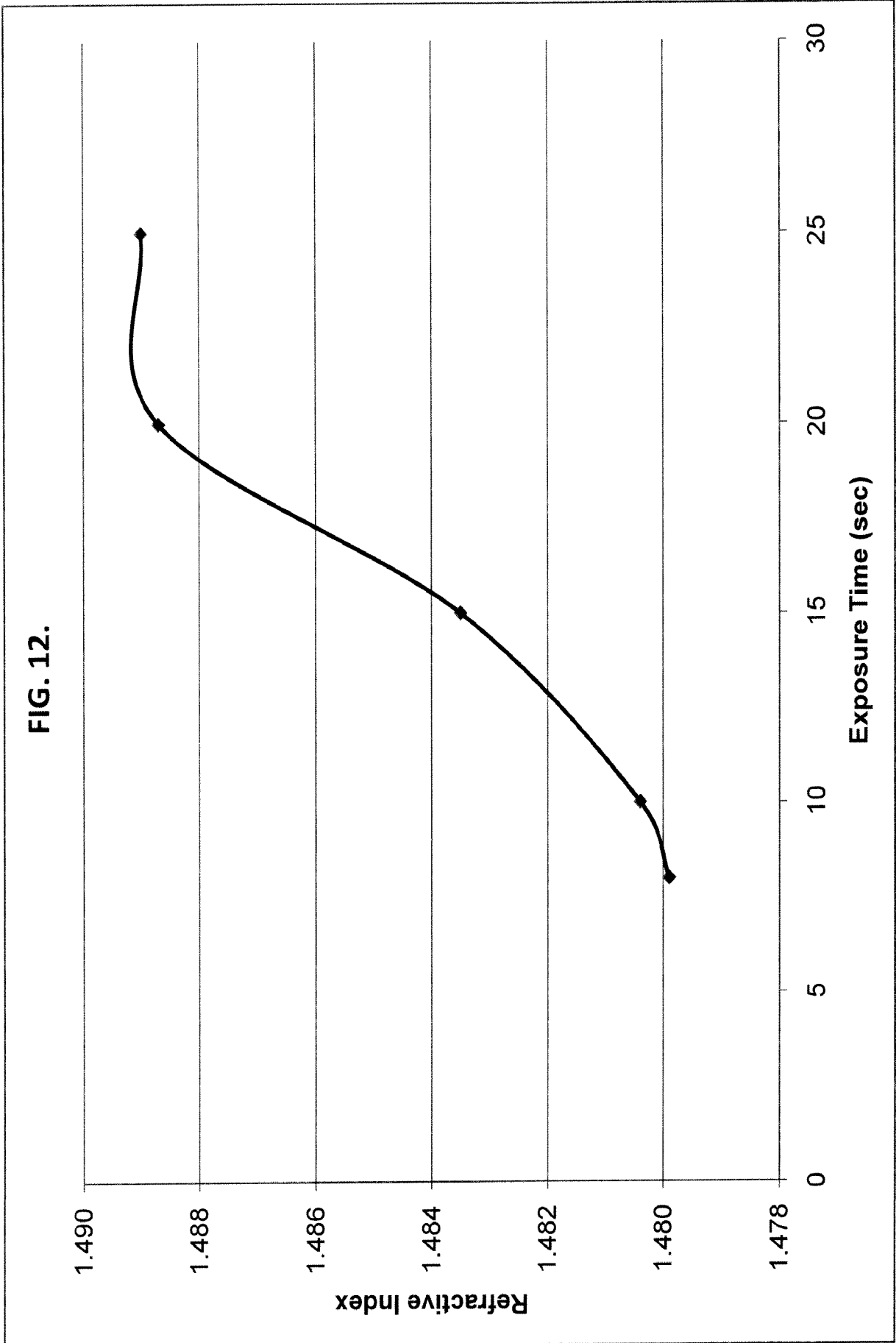
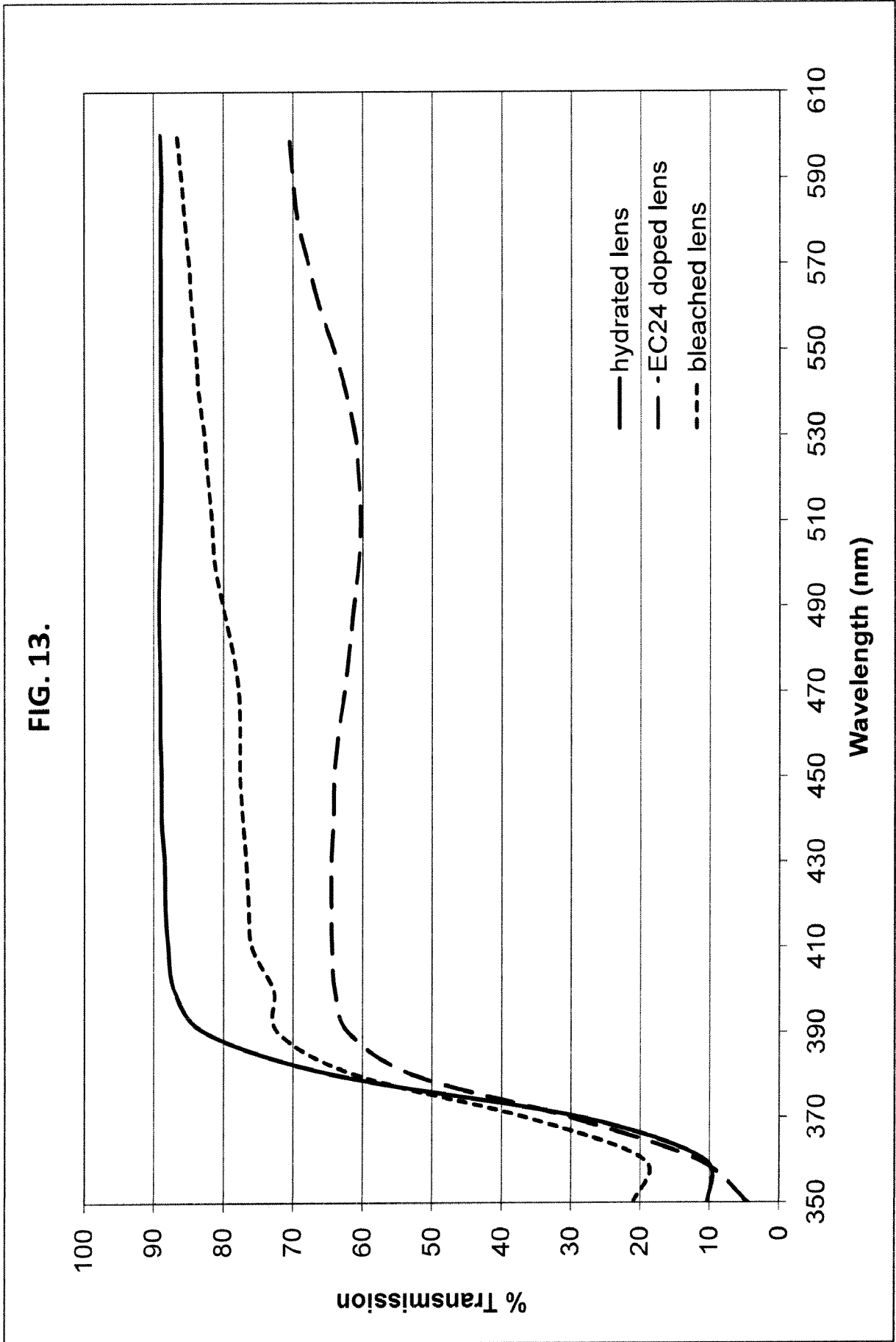

FIG. 13.



INTERNATIONAL SEARCH REPORT

International application No. PCT/US2009/039409
--

A. CLASSIFICATION OF SUBJECT MATTER
 IPC(8) - A61F 2/16 (2009.01)
 USPC - 623/6.17
 According to International Patent Classification (IPC) or to both national classification and IPC

B. FIELDS SEARCHED

Minimum documentation searched (classification system followed by classification symbols)
 IPC(8) - A61F 2/16; G02B 1/10; G02C 7/10 (2009.01)
 USPC - 351/163; 359/581; 523/106; 623/6.17, 6.6, 6.62

Documentation searched other than minimum documentation to the extent that such documents are included in the fields searched

Electronic data base consulted during the international search (name of data base and, where practicable, search terms used)
 PatBase, Google Search

C. DOCUMENTS CONSIDERED TO BE RELEVANT

Category*	Citation of document, with indication, where appropriate, of the relevant passages	Relevant to claim No.
X - Y	US 7,074,840 B2 (CHANG et al) 11 July 2006 (11.07.2006) entire document	1, 4, 6-8, 13-22, 27 ----- 2, 3, 5, 9-12, 23-26
Y	US 6,187,042 B1 (SHEETS, JR. et al) 13 February 2001 (13.02.2001) entire document	2, 5
Y	US 6,458,865 B2 (CHAPPELOW et al) 01 October 2002 (01.10.2002) entire document	3
Y	US 2006/0106262 A1 (MCGINNISS et al) 18 May 2006 (18.05.2006) entire document	9, 10, 23, 24
Y	US 2003/0022105 A1 (PRASAD et al) 30 January 2003 (30.01.2003) entire document	11, 25
Y	US 2007/0100018 A1 (HAGTING et al) 03 May 2007 (03.05.2007) entire document	12, 26

Further documents are listed in the continuation of Box C.

* Special categories of cited documents:

“A” document defining the general state of the art which is not considered to be of particular relevance	“T” later document published after the international filing date or priority date and not in conflict with the application but cited to understand the principle or theory underlying the invention
“E” earlier application or patent but published on or after the international filing date	“X” document of particular relevance; the claimed invention cannot be considered novel or cannot be considered to involve an inventive step when the document is taken alone
“L” document which may throw doubts on priority claim(s) or which is cited to establish the publication date of another citation or other special reason (as specified)	“Y” document of particular relevance; the claimed invention cannot be considered to involve an inventive step when the document is combined with one or more other such documents, such combination being obvious to a person skilled in the art
“O” document referring to an oral disclosure, use, exhibition or other means	“&” document member of the same patent family
“P” document published prior to the international filing date but later than the priority date claimed	

Date of the actual completion of the international search 26 May 2009	Date of mailing of the international search report 04 JUN 2009
--	--

Name and mailing address of the ISA/US Mail Stop PCT, Attn: ISA/US, Commissioner for Patents P.O. Box 1450, Alexandria, Virginia 22313-1450 Facsimile No. 571-273-3201	Authorized officer: Blaine R. Copenheaver PCT Helpdesk: 571-272-4300 PCT OSP: 571-272-7774
---	---