



US 20230332574A1

(19) **United States**

(12) **Patent Application Publication**

HUG et al.

(10) **Pub. No.: US 2023/0332574 A1**

(43) **Pub. Date: Oct. 19, 2023**

(54) **VERTICAL WIND TURBINE COMPRISING ROTOR BLADE-SUPPORTING PITCH MOTOR, AS WELL AS KIT FOR SAME, AND METHOD FOR OPERATING SAME**

F03D 80/70 (2006.01)

F03D 3/00 (2006.01)

(52) **U.S. Cl.**

CPC *F03D 7/06* (2013.01); *F03D 80/60* (2016.05); *F03D 80/70* (2016.05); *F03D 3/005* (2013.01); *F05B 2260/76* (2013.01); *F05B 2260/72* (2013.01); *F05B 2260/79* (2013.01); *F03D 3/068* (2013.01)

(71) Applicant: **AGILE WIND POWER AG**,
Dübendorf (CH)

(72) Inventors: **Thomas Hans HUG**, Weisslingen (CH); **Christian ORAM**, Berg am Irchel (CH); **Johannes WENGER**, Birmensdorf (CH)

(21) Appl. No.: **17/977,633**

(22) Filed: **Oct. 31, 2022**

Related U.S. Application Data

(63) Continuation of application No. 16/625,891, filed on Dec. 23, 2019, now Pat. No. 11,519,387, filed as application No. PCT/EP2018/067582 on Jun. 29, 2018.

(30) **Foreign Application Priority Data**

Jun. 30, 2017 (WO) PCT/IB2017/053972
Jun. 30, 2017 (WO) PCT/IB2017/053974

Publication Classification

(51) **Int. Cl.**
F03D 7/06 (2006.01)
F03D 80/60 (2006.01)

(57) **ABSTRACT**

The present invention relates to a vertical wind turbine (1) with a plurality of vertical blades (7), which are each supported such that they are motor-driven pivotable around a respective blade rotation axis (C_7) independently of one another, and are rotatable on a common circular path (K) around a vertical rotor rotation axis (C_2), and to a method for operating the vertical wind turbine (1), wherein angular positions of vertical blades (7) of the vertical wind turbine (1), which are each supported such that they are rotatable around a respective vertical rotor rotation axis (C_2) and are motor-driven pivotable around a respective blade rotation axis (C_7) independently of one another, are being predetermined. According to the invention, the vertical wind turbine (1) is operated in a particularly efficient and material-protecting way in that the angular positions of the blades (7) are each predetermined by means of at least one pitch motor (27) at least partially supporting the respective blade (7).

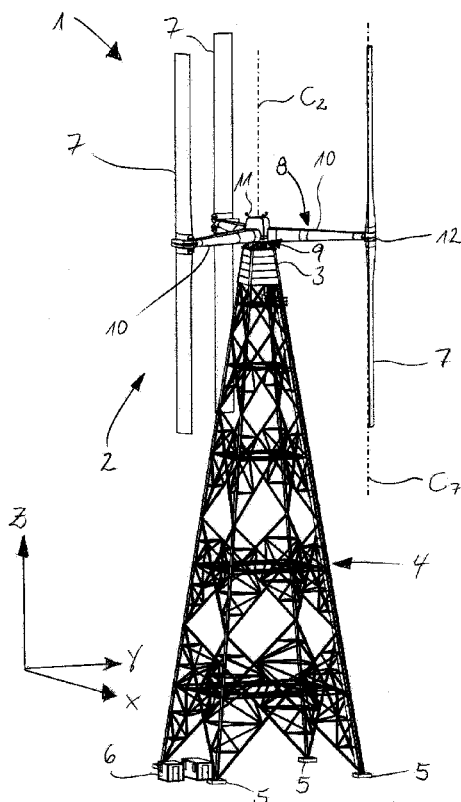

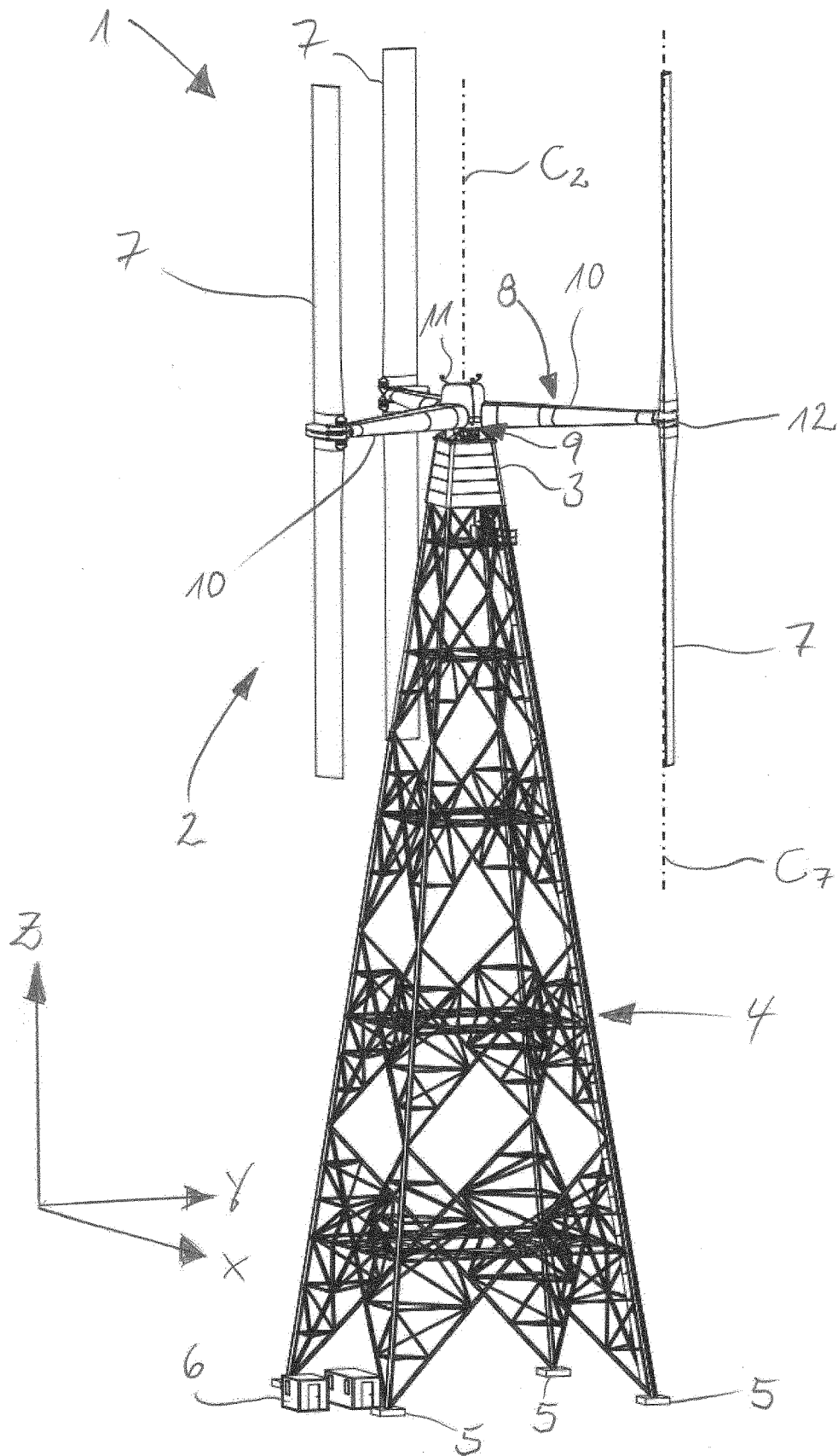

Fig. 1

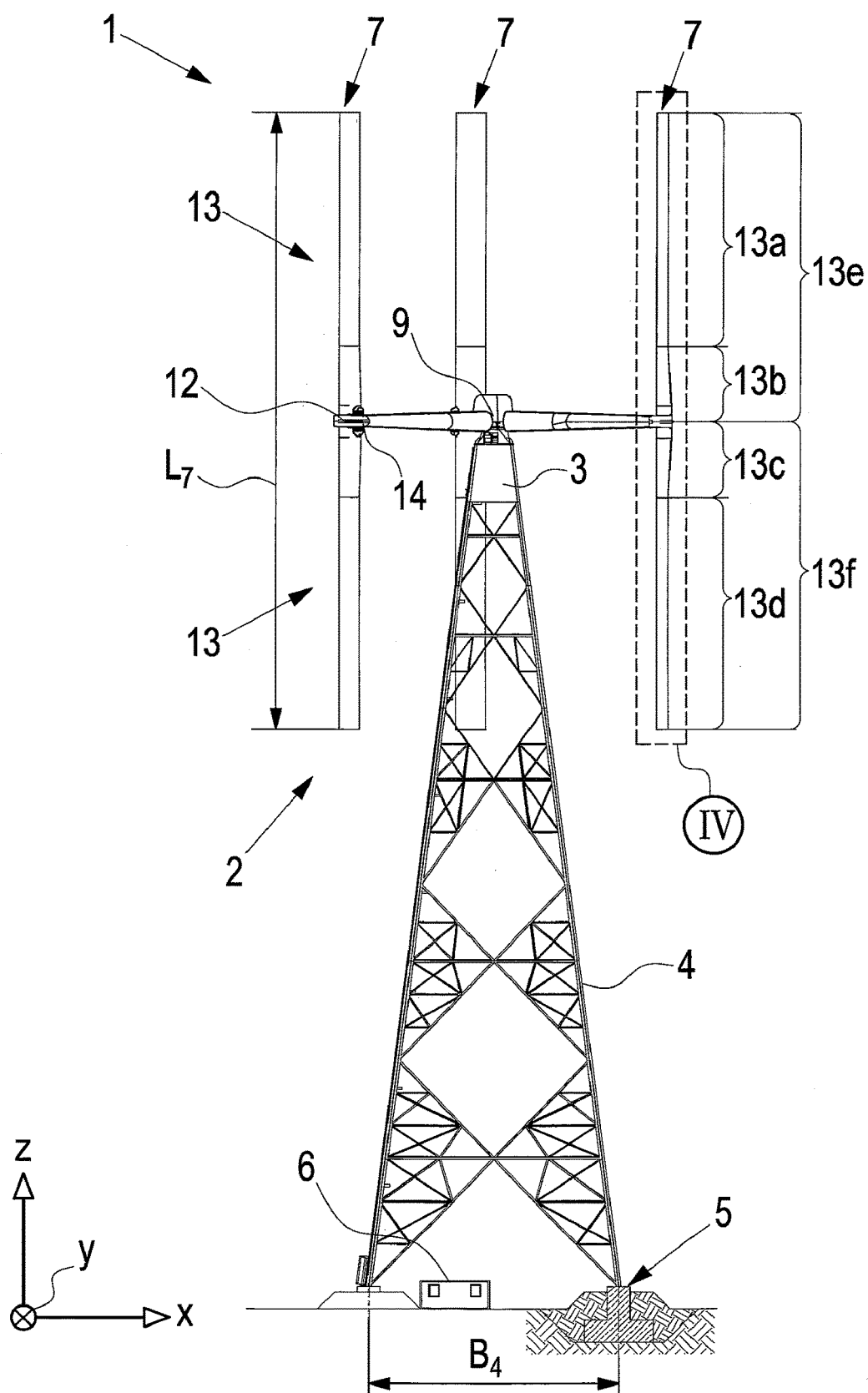

Fig. 2

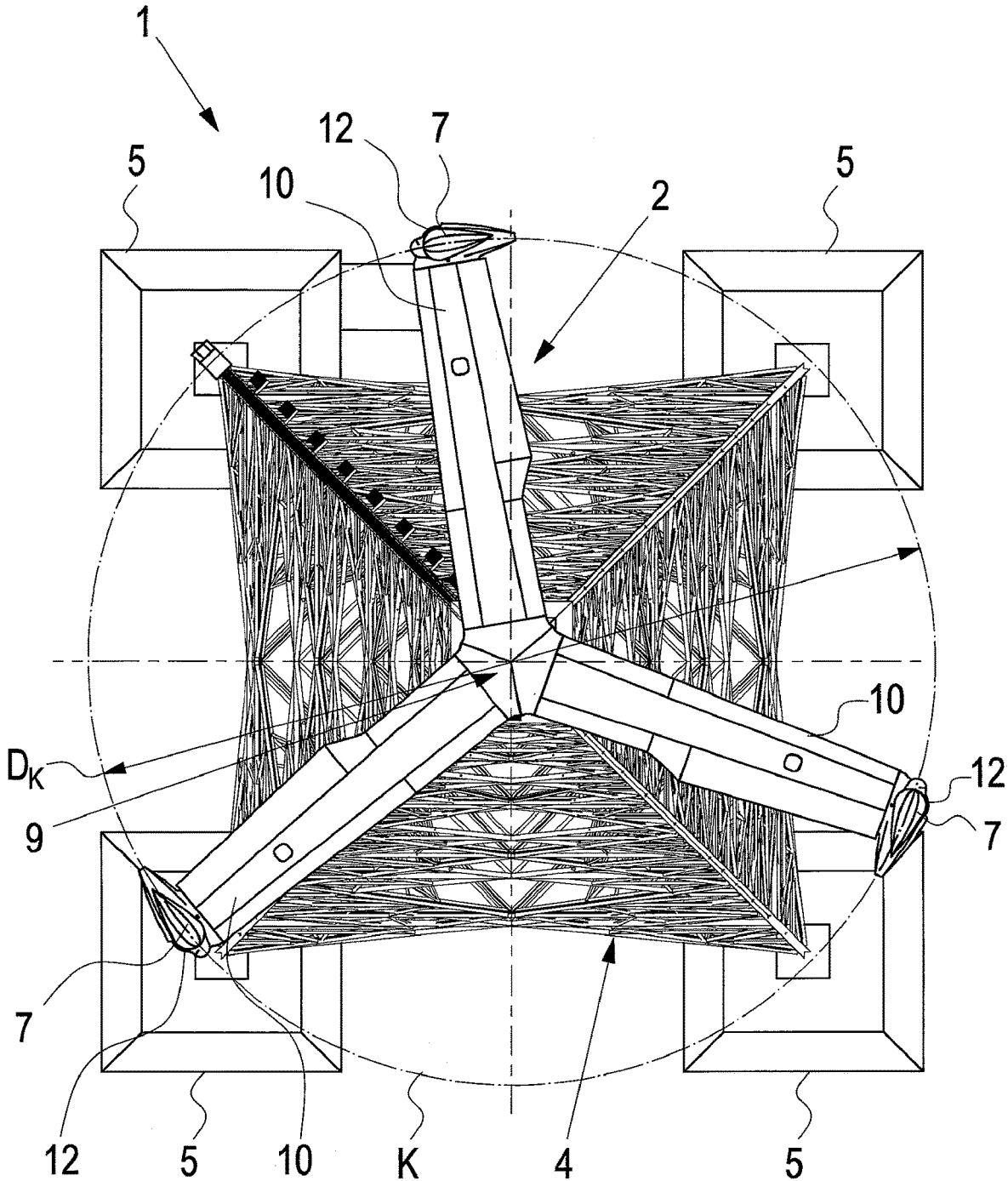

Fig. 3

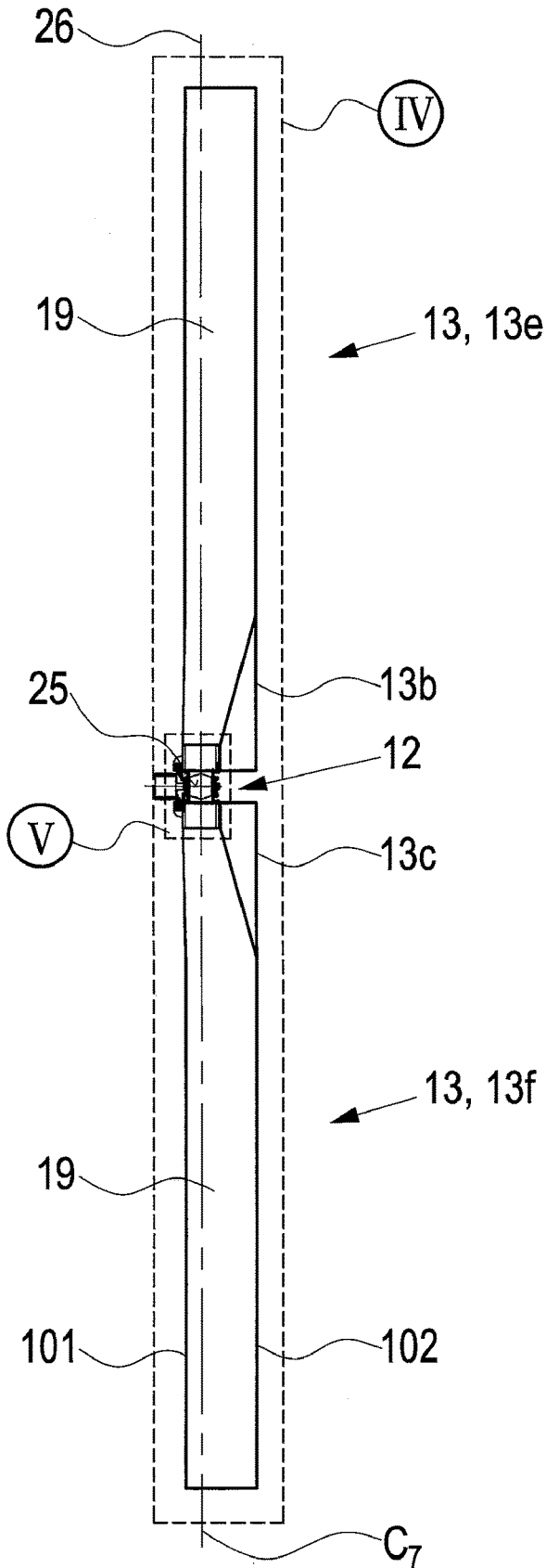

Fig. 4

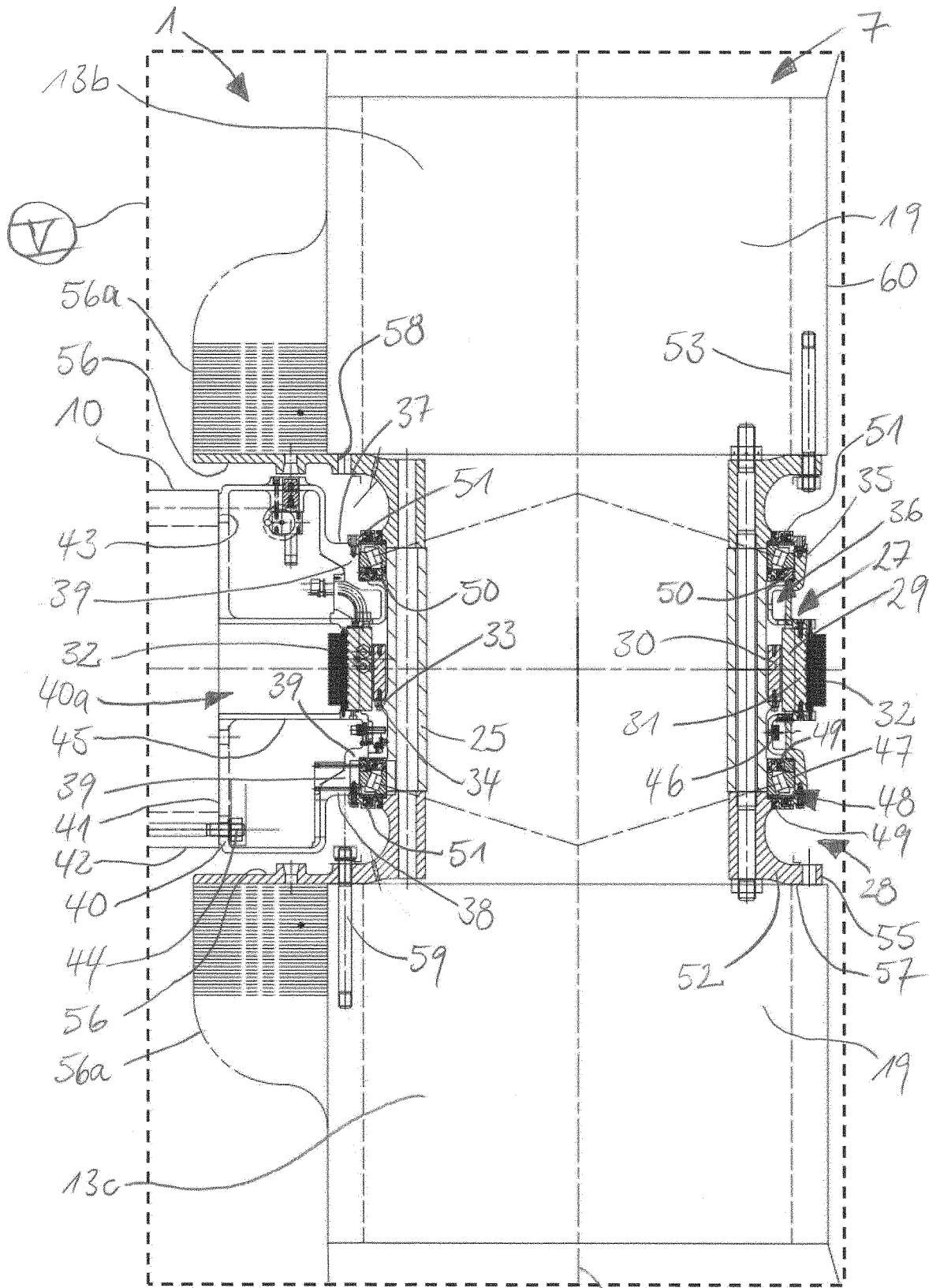

Fig. 5

C7

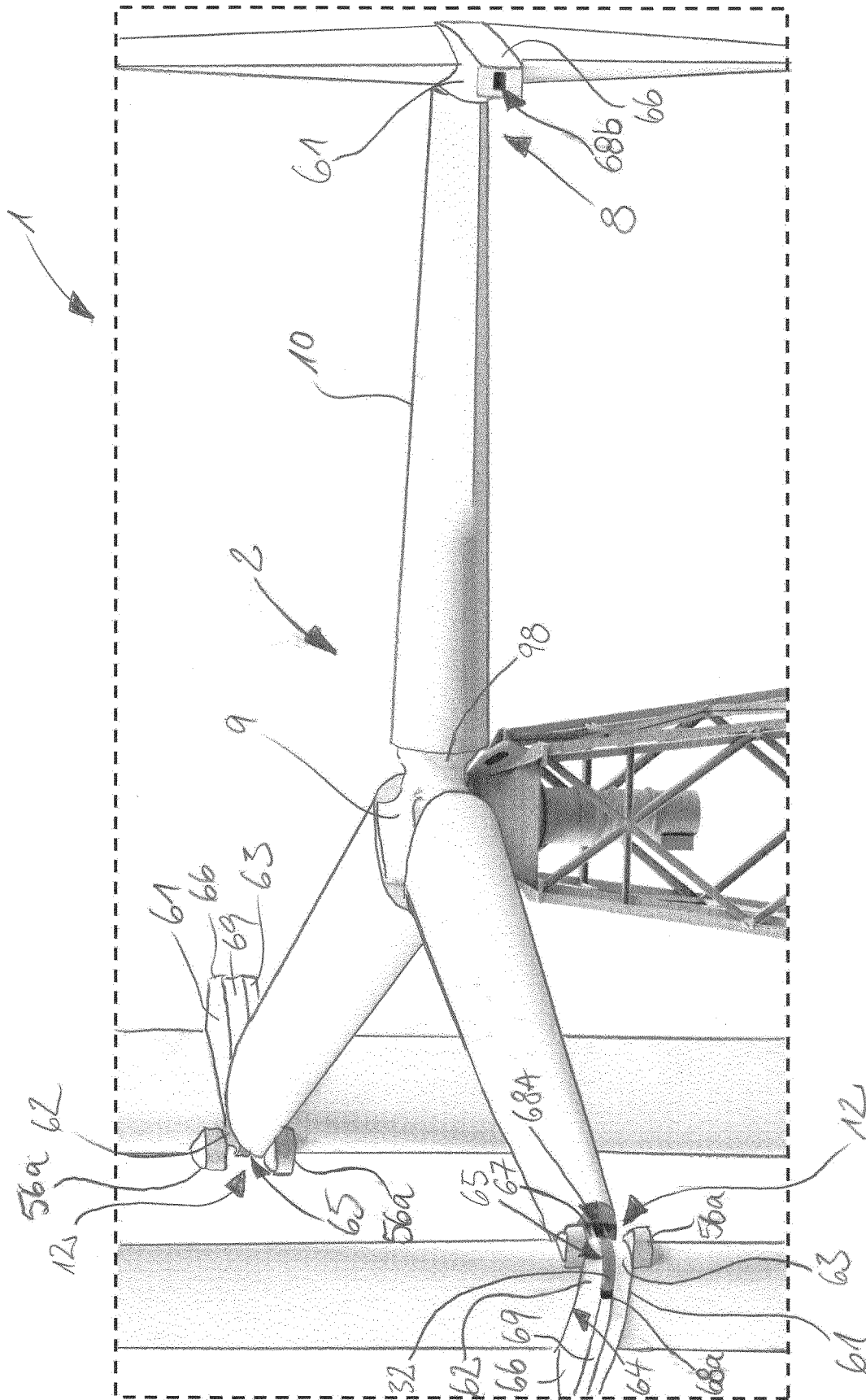

Fig. 6

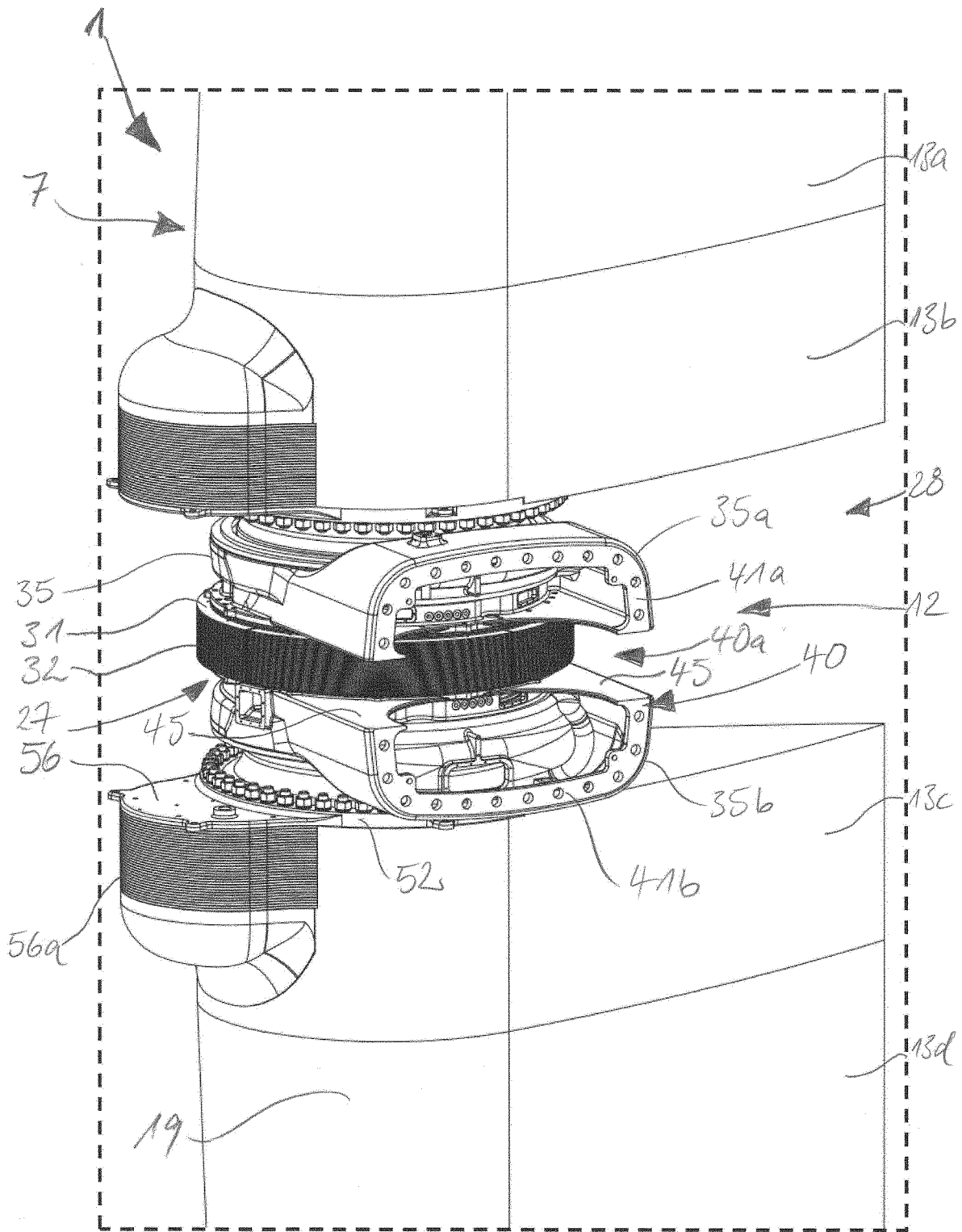

Fig. 7

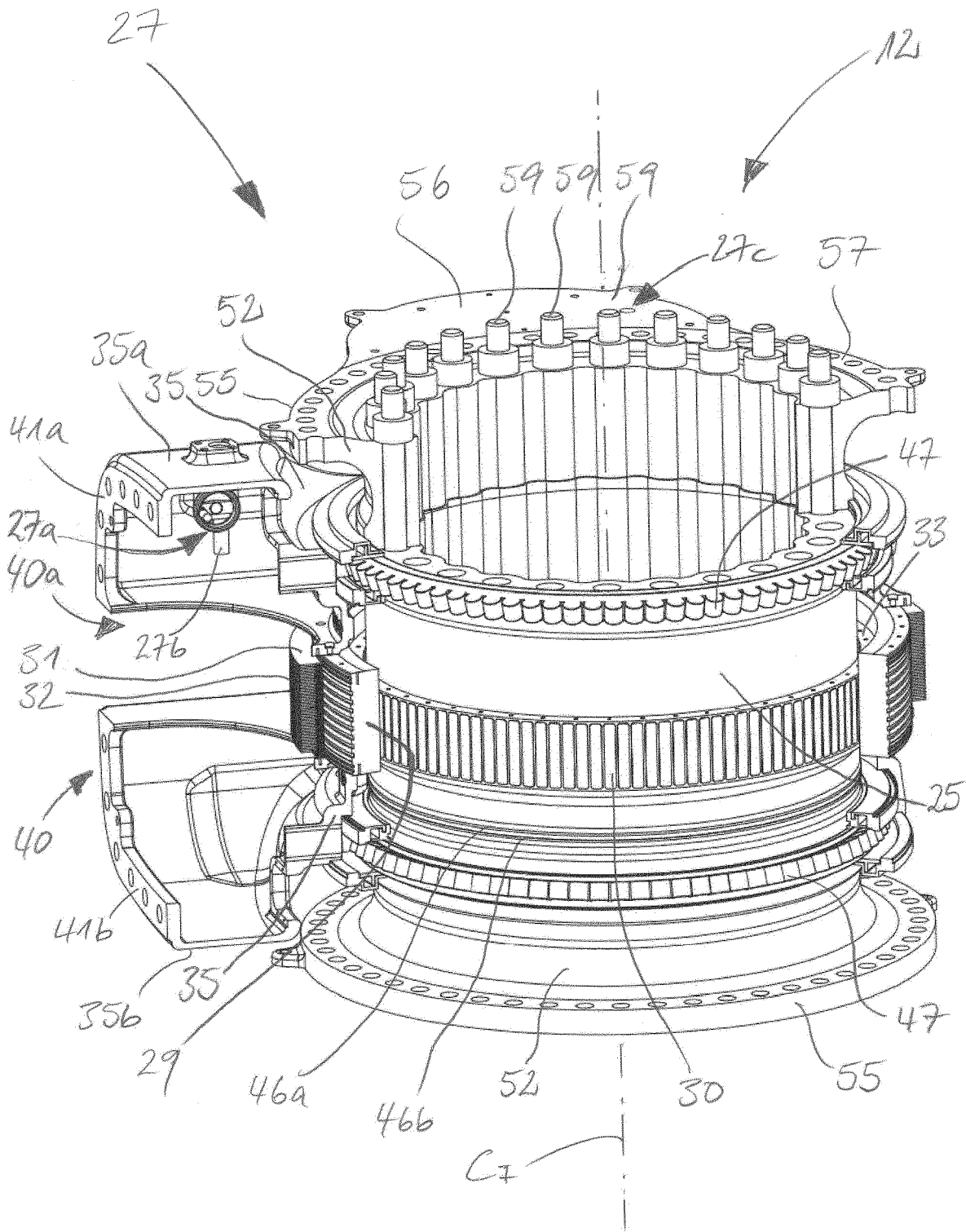

Fig. 8

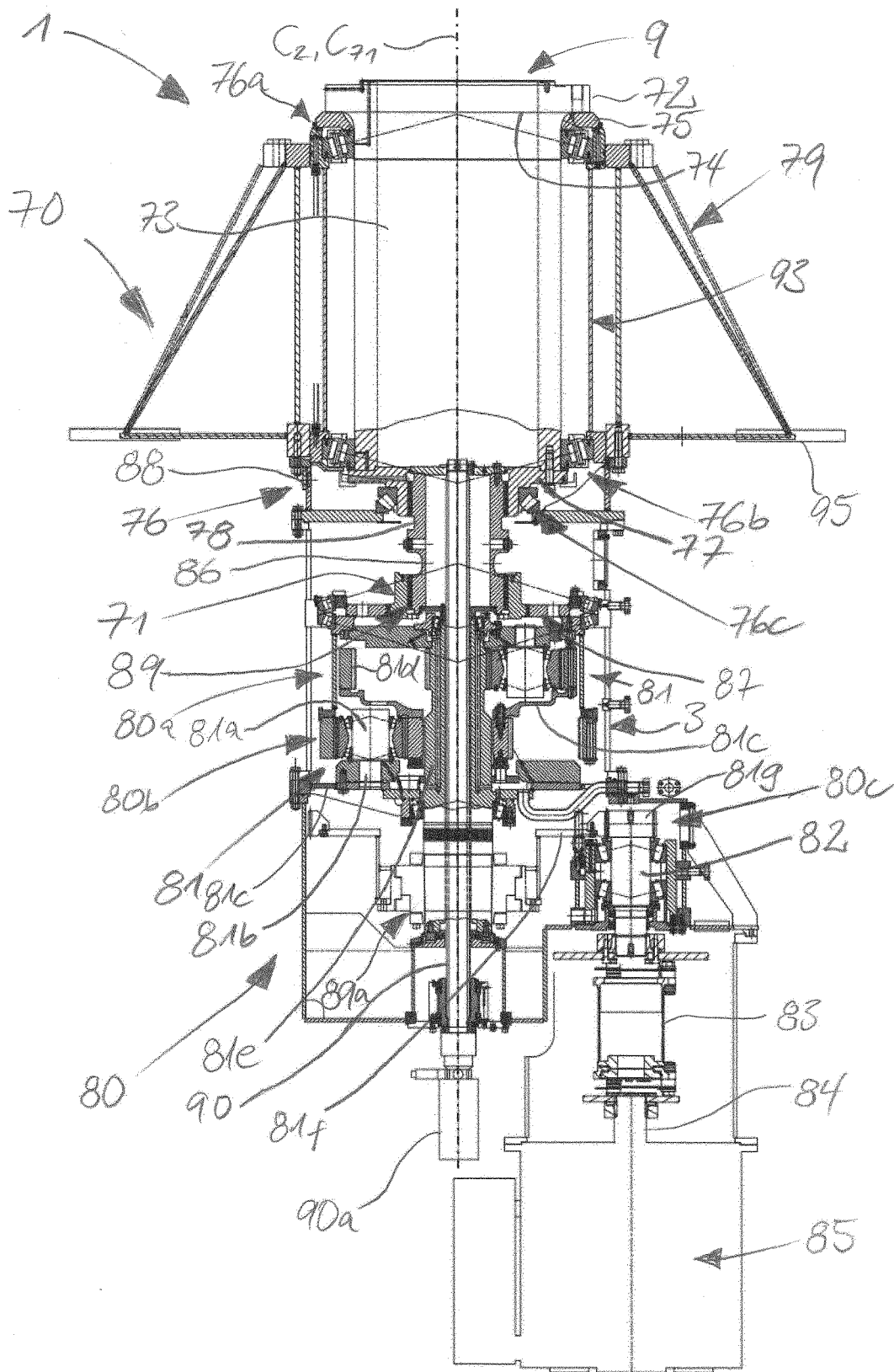

Fig. 9

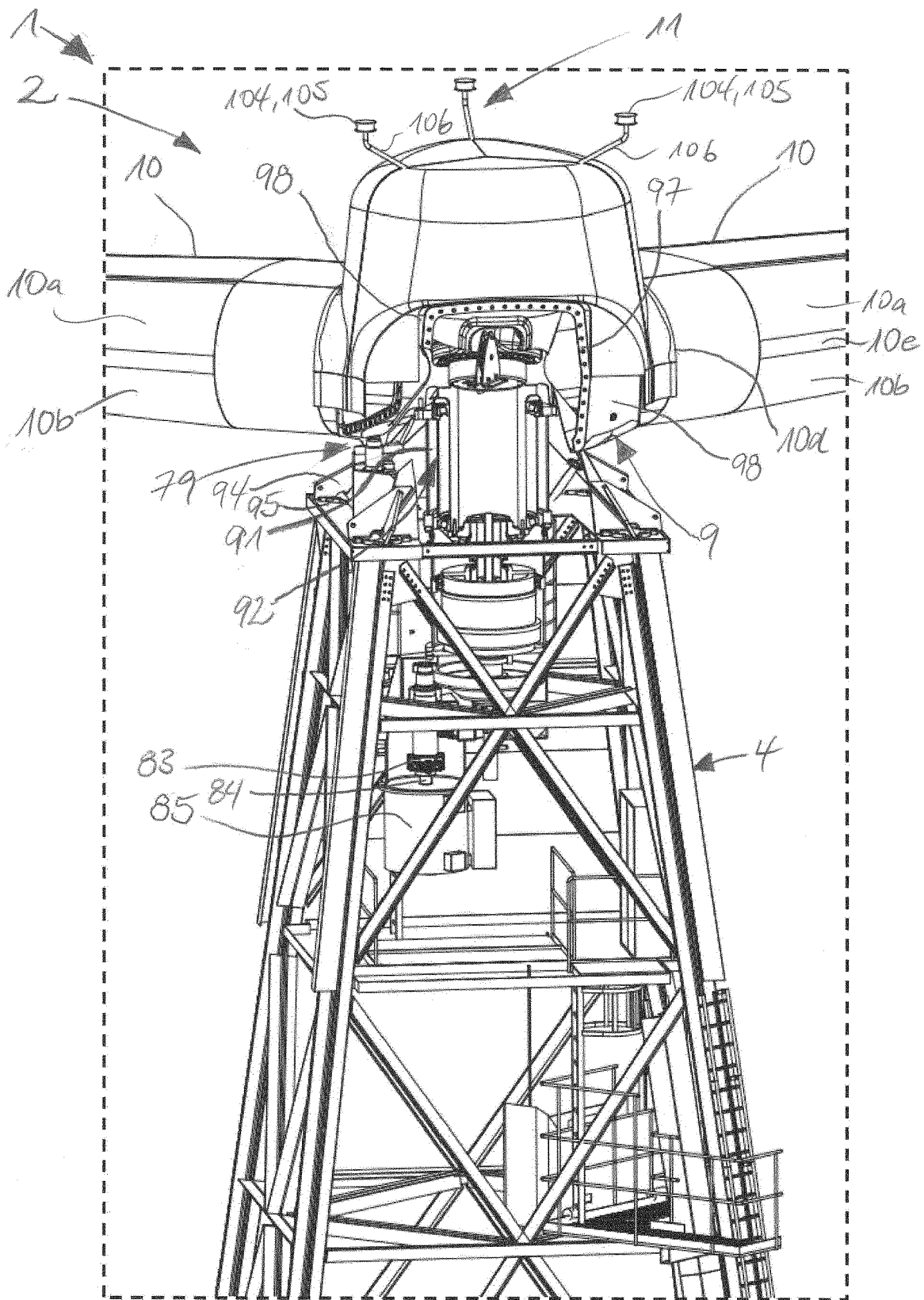

Fig. 10

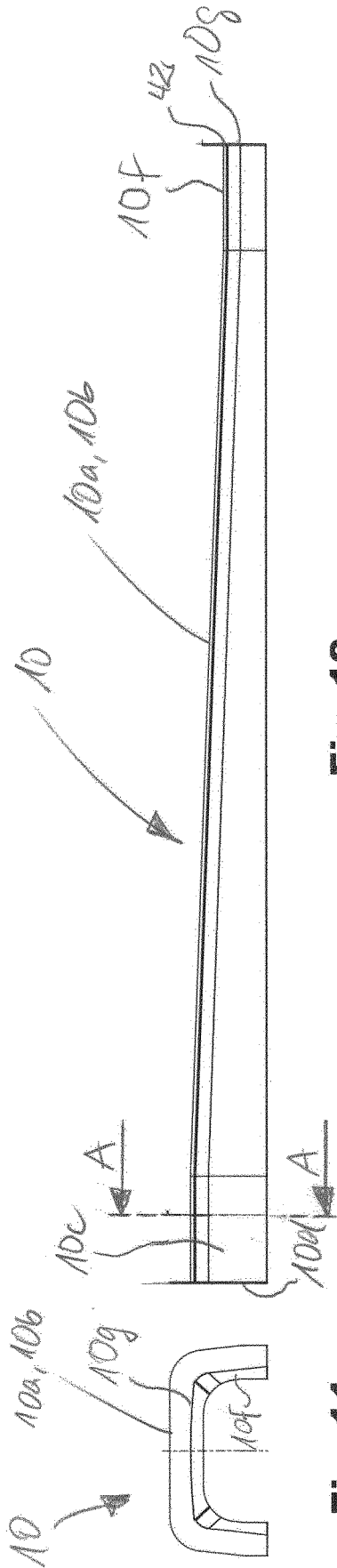

Fig. 11

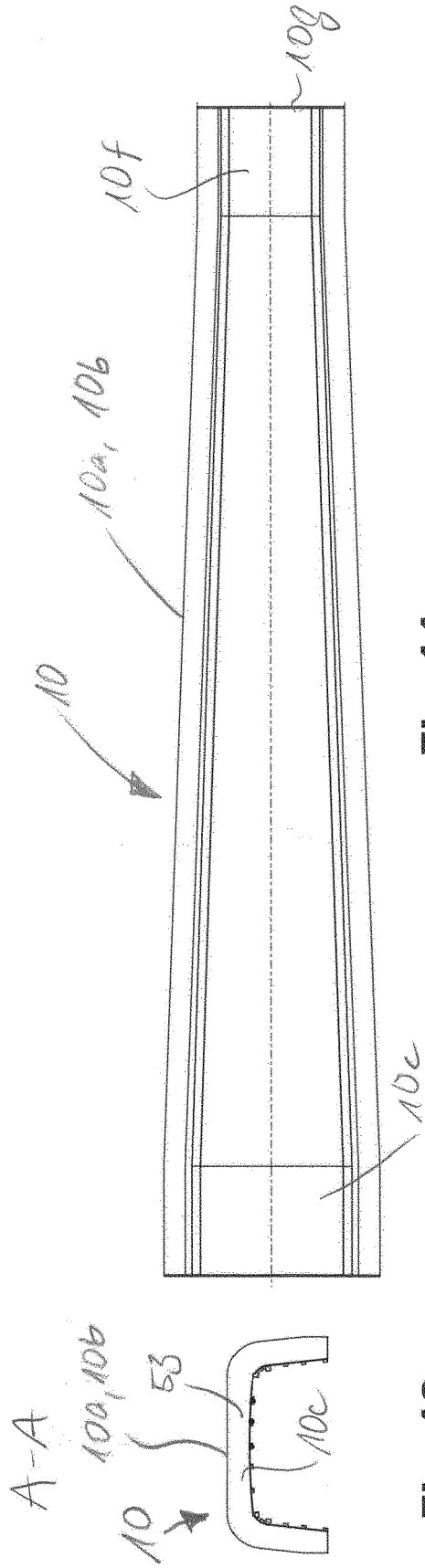

Fig. 13

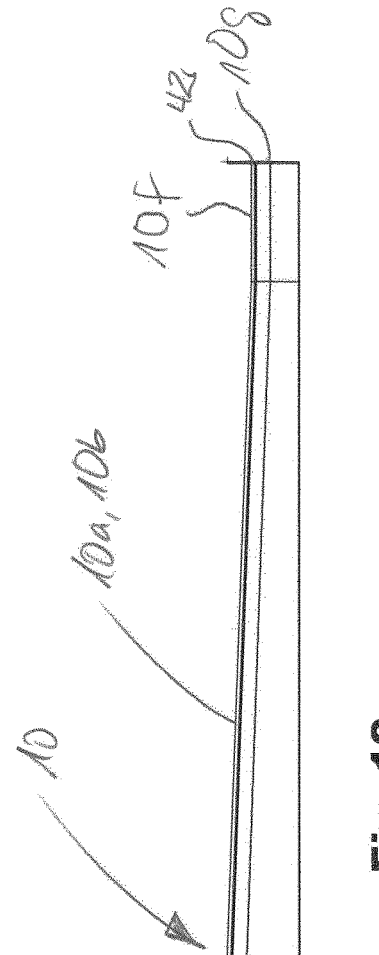

Fig. 12

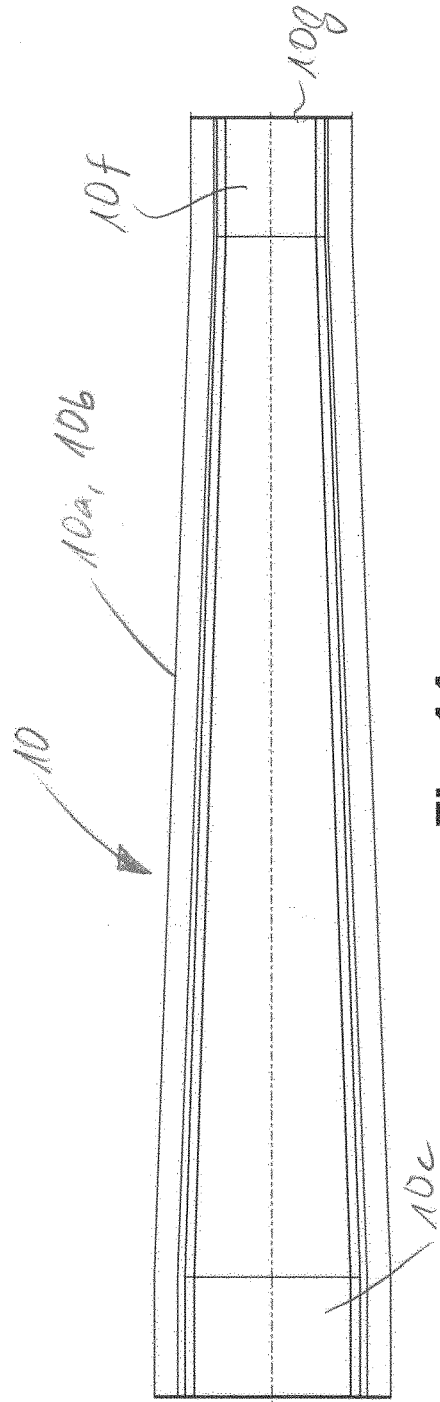

Fig. 14

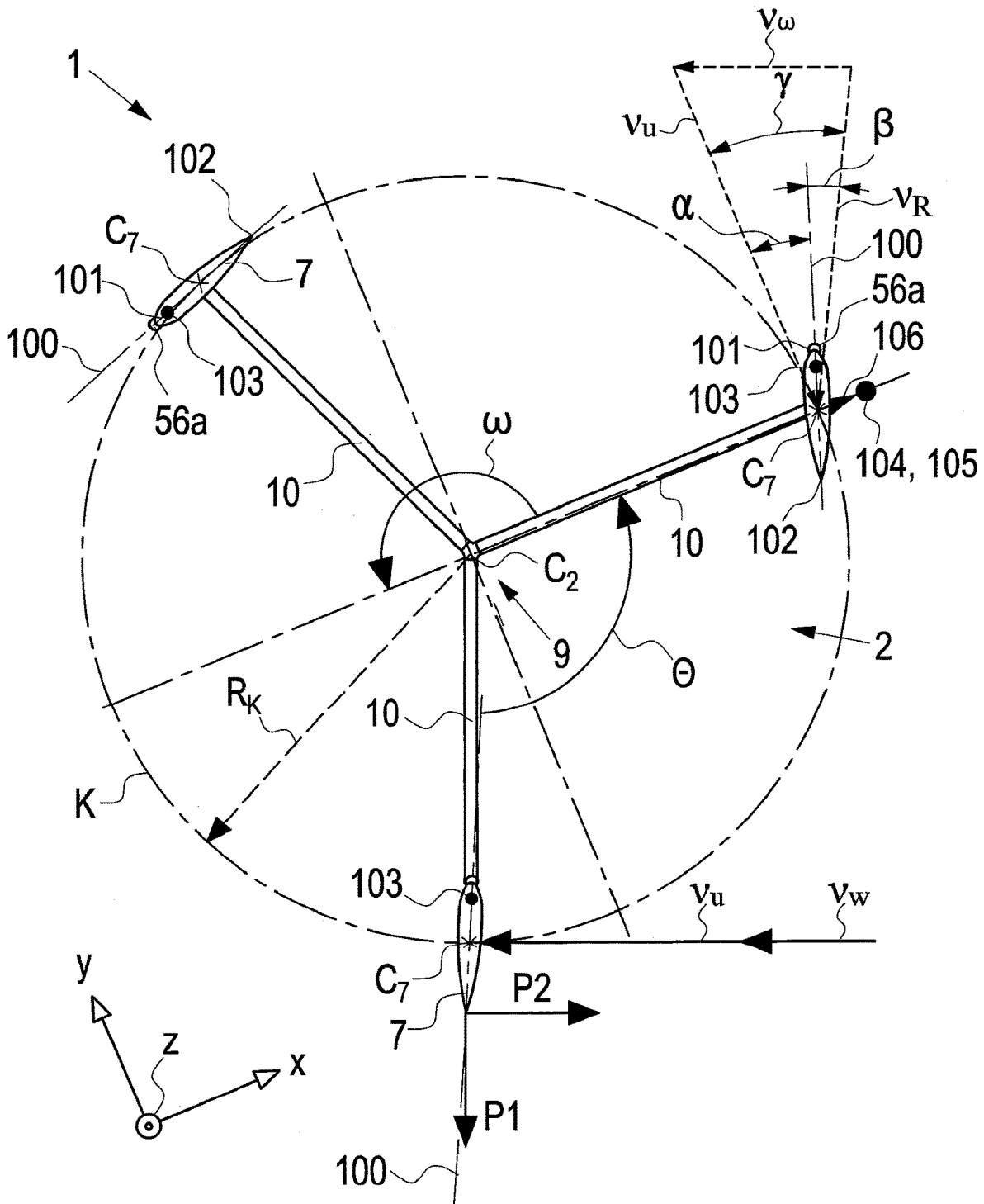

Fig. 15

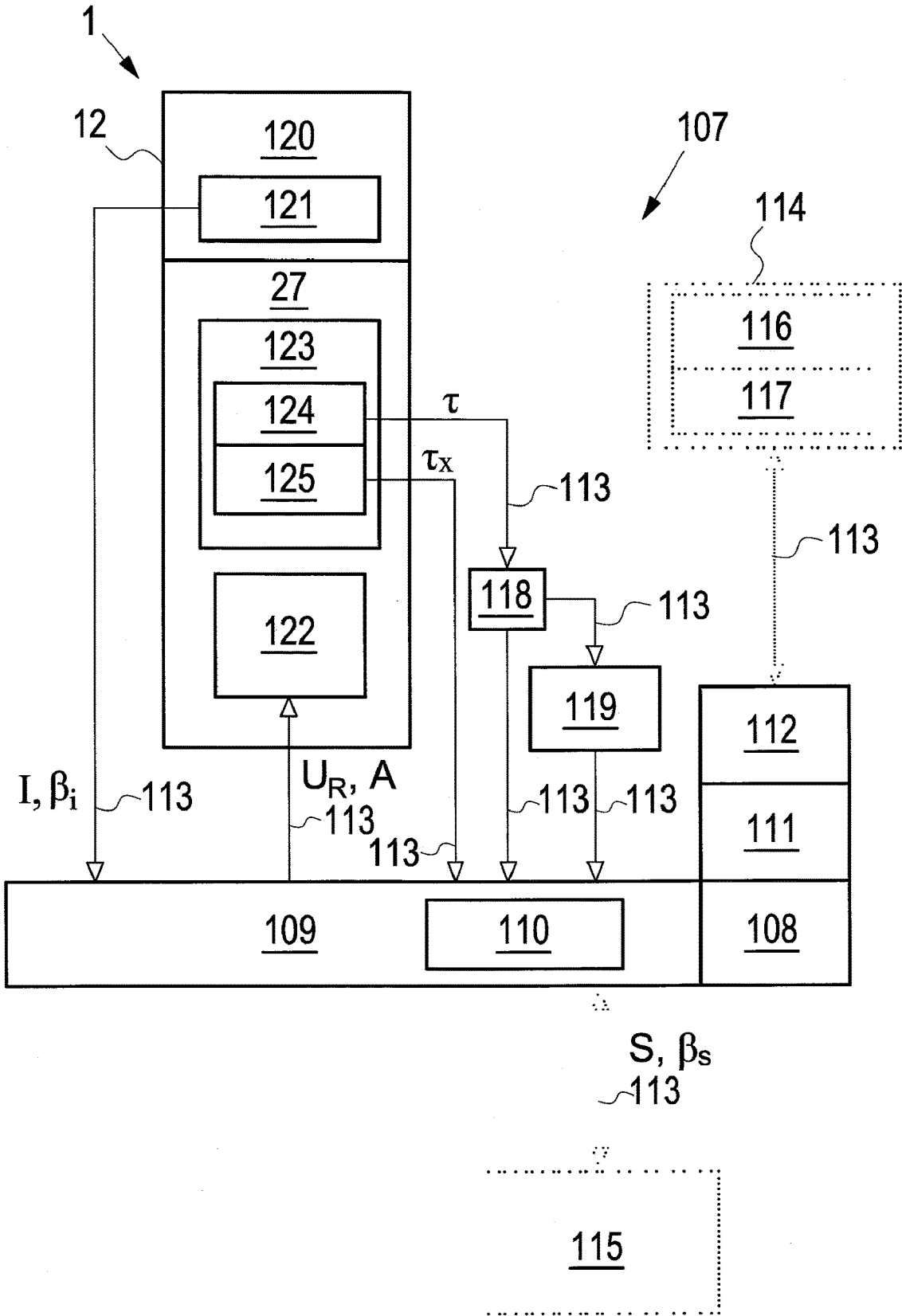

Fig. 16

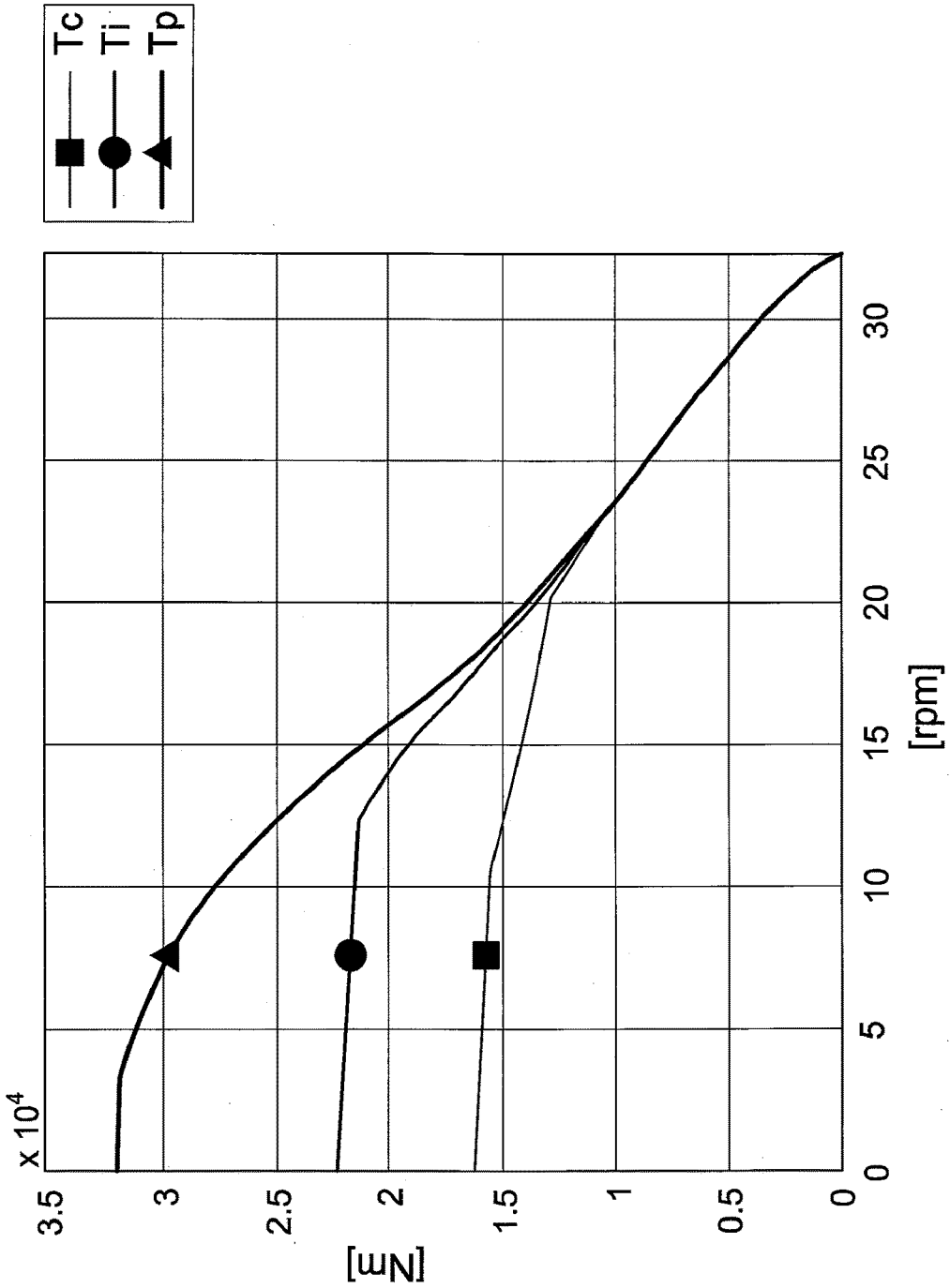

Fig. 17

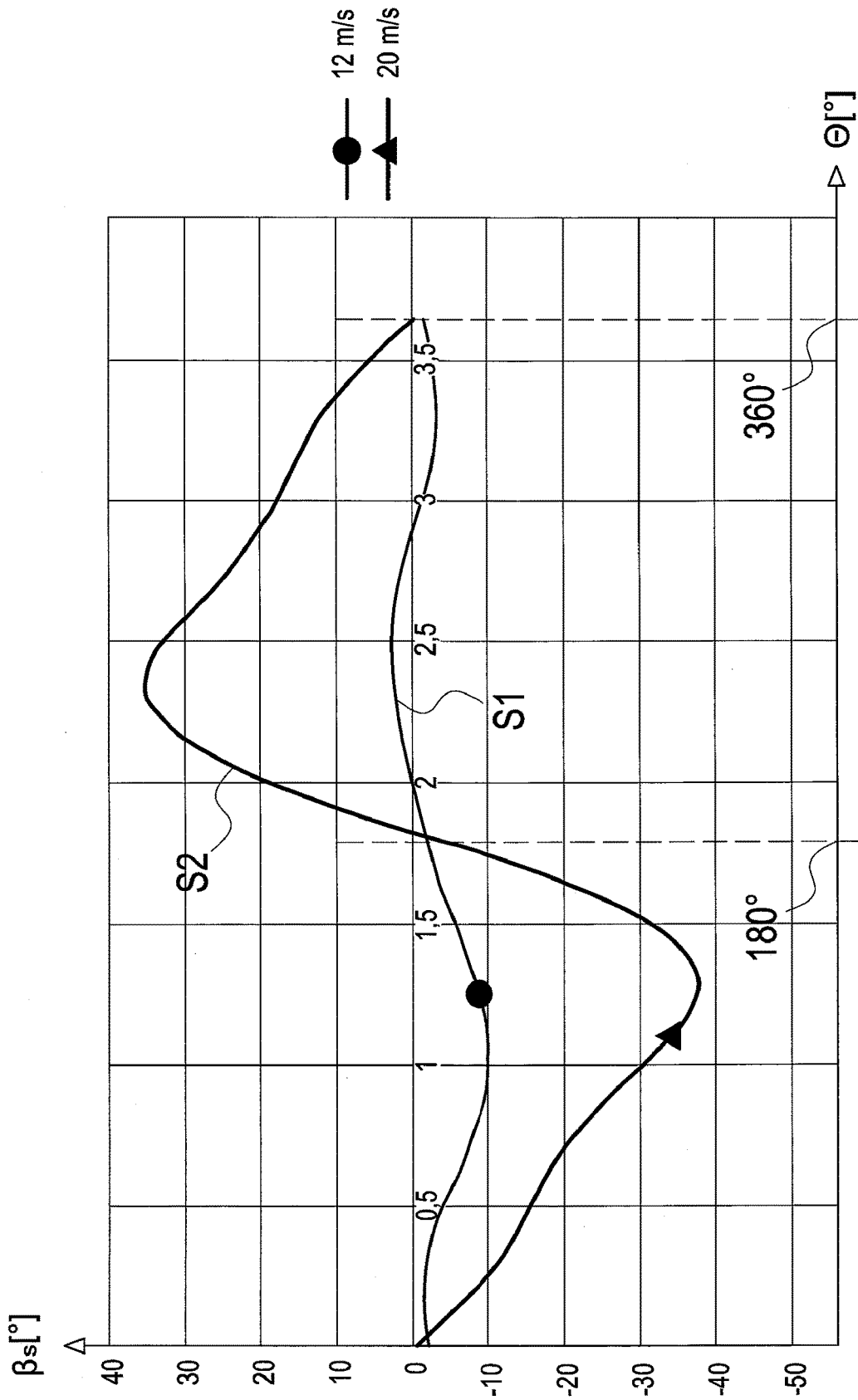

Fig. 18

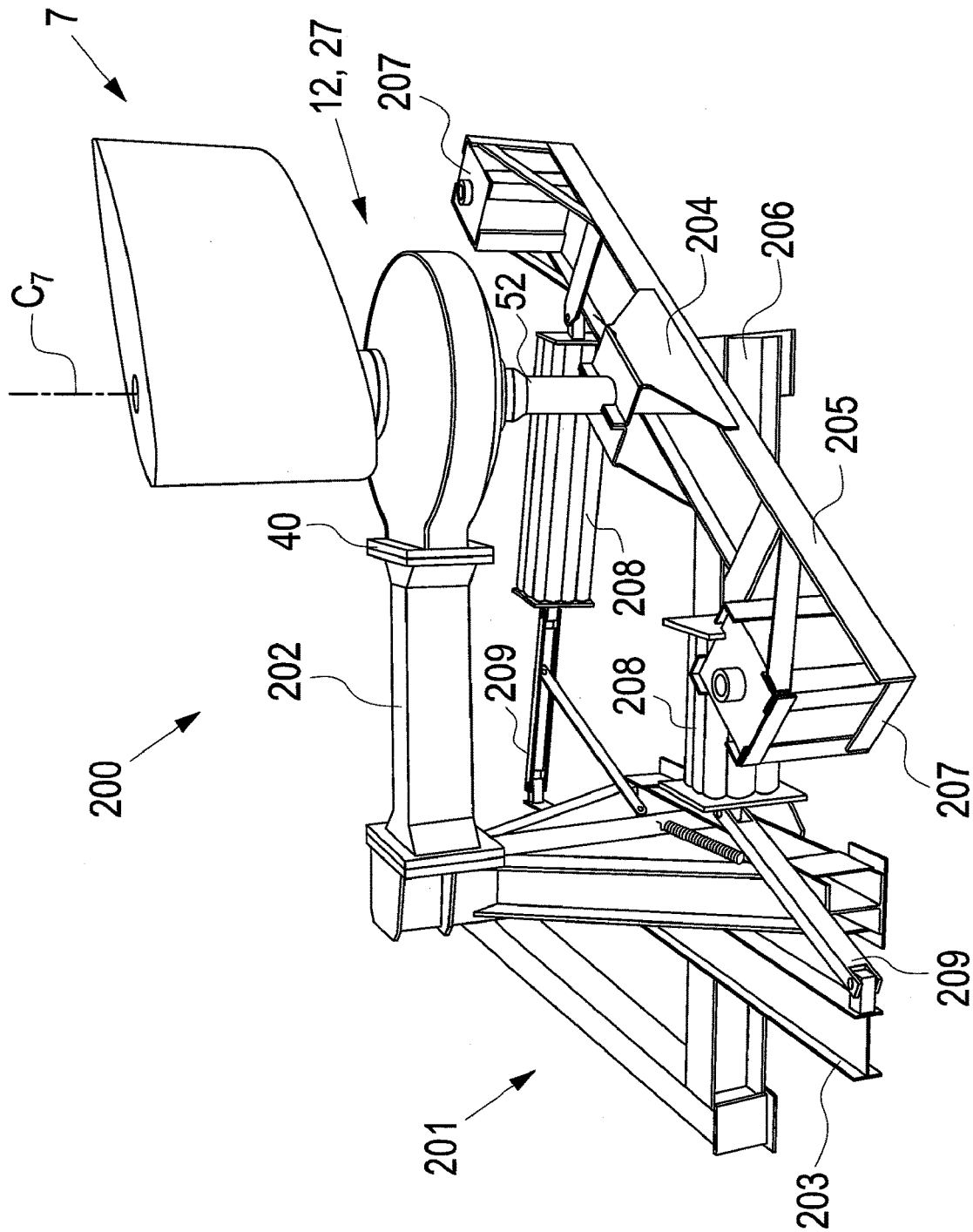

Fig. 19

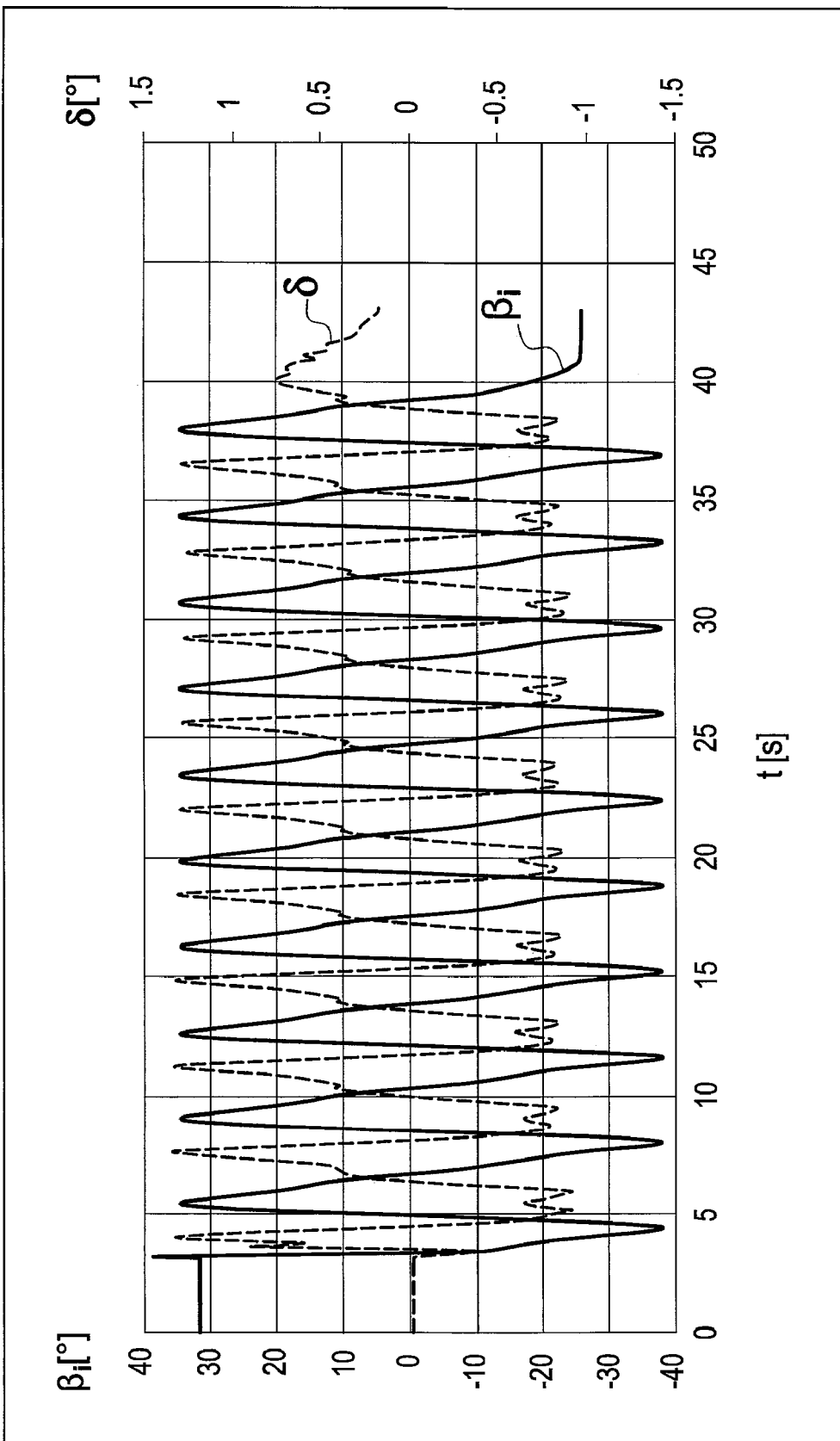

Fig. 20

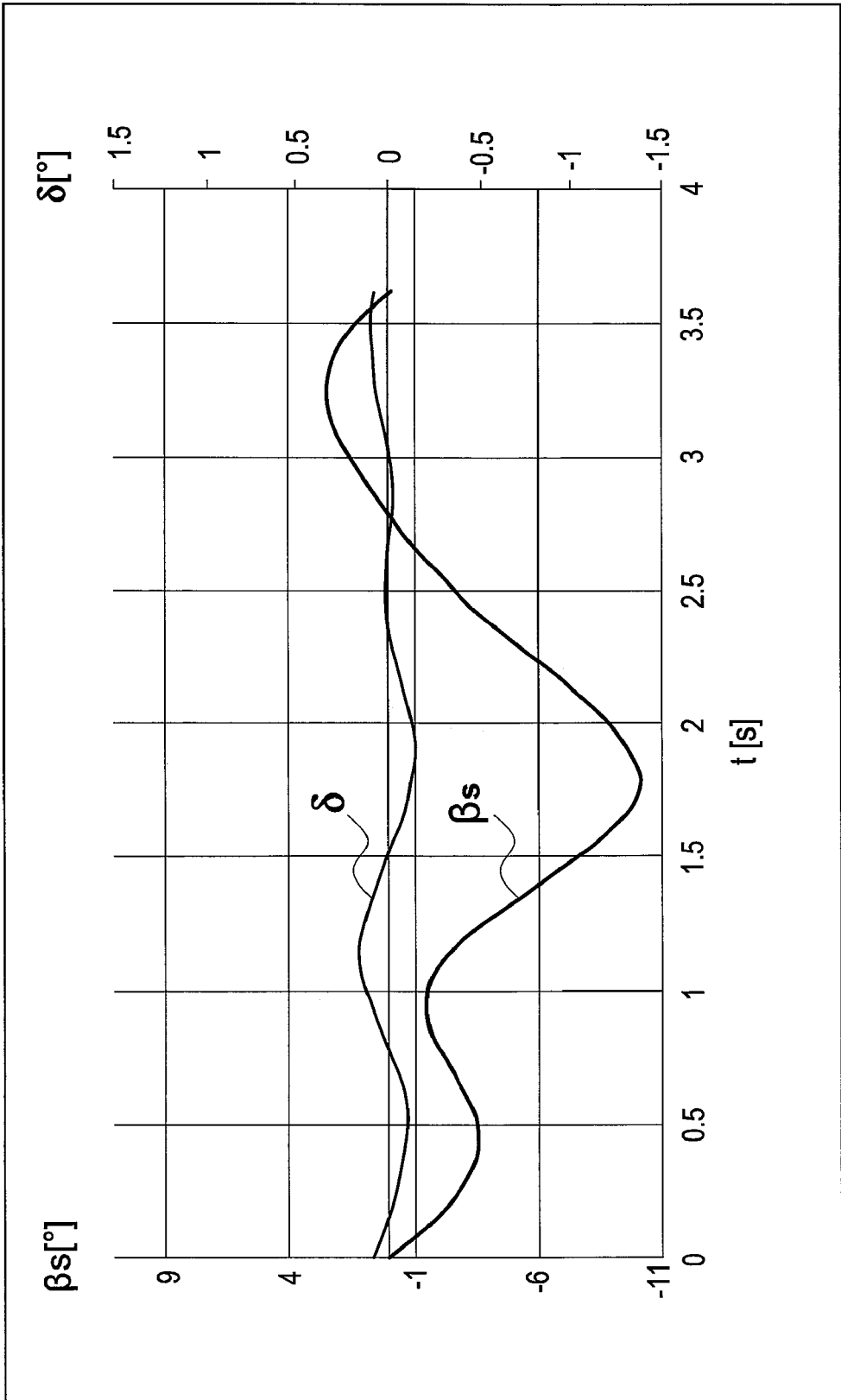

Fig. 21

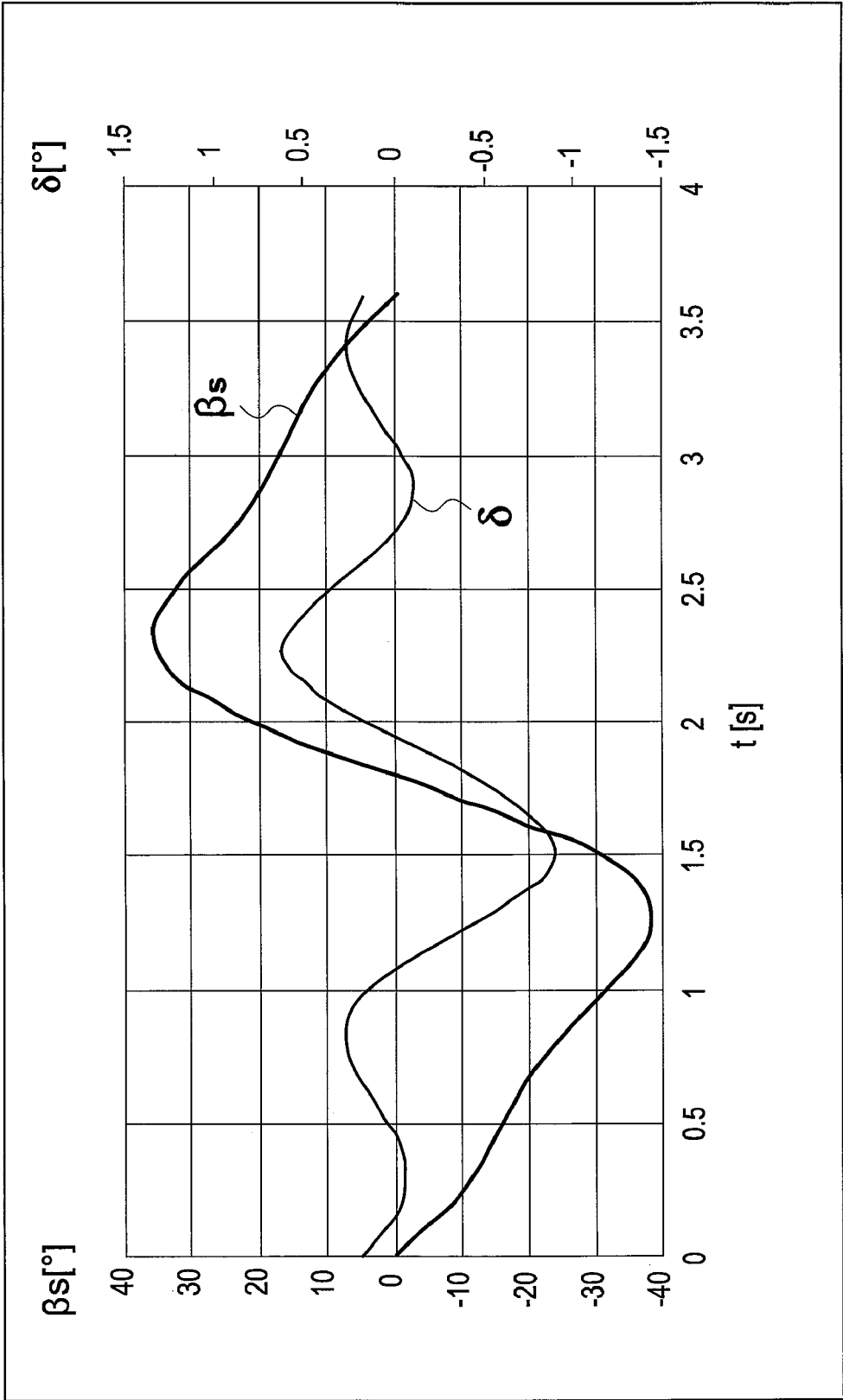

Fig. 22

**VERTICAL WIND TURBINE COMPRISING
ROTOR BLADE-SUPPORTING PITCH
MOTOR, AS WELL AS KIT FOR SAME, AND
METHOD FOR OPERATING SAME**

**CROSS-REFERENCE TO RELATED
APPLICATIONS**

[0001] The present application is a Continuation of U.S. application Ser. No. 16/625,891, filed Dec. 23, 2019, which is a 35 U.S.C. §§ 371 national stage application of International Application No. PCT/EP2018/067582, filed Jun. 29, 2018, PCT Application No. PCT/IB2017/053972, filed Jun. 30, 2017, and PCT Application No. PCT/IB2017/053974, filed Jun. 30, 2017, the contents of which are incorporated herein by reference.

FIELD OF INVENTION

[0002] The present invention relates to a vertical wind turbine, as well as a kit for a vertical wind turbine, and a method for operating a vertical wind turbine.

TECHNOLOGICAL BACKGROUND

[0003] Vertical wind turbines with active blade control are known from the prior art. WO 2015/185299 A1 on behalf of the applicant discloses a vertical wind turbine with vertical blades, that are each driven by a servomotor via a transmission into a predetermined rotational position around their respective axis of rotation, which position can be changed at anytime; virtual cam disks are provided, which respectively determine the course of the blade angle by means of the position of the blade on the circle of revolution, and wherein the active control is carried out in accordance with the virtual cam disks.

[0004] Further, European patent EP 2 235 365 B1 on behalf of the applicant relates to a wind turbine with at least one rotor, which can be rotated around a vertical axis and which, between two horizontal bearing planes disposed at a distance on top of each other, comprises a plurality of rotor blades, which are disposed uniformly distributed on a circumferential circle and can each be pivoted around a vertical pivot axis and the pivot range of which is delimited on both sides by a limit stop.

[0005] Furthermore, the document U.S. Pat. No. 3,902, 072 A discloses a wind powered generator with a horizontal, rotating platform on the outer circumference of which a plurality of vertical blades is positioned, which all revolve coaxially around a central axis and each rotate around an individual axis. The rotation of the vertical blades depends on changes in the wind direction and wind speed and the rotation of each individual blade is controlled so that for $\frac{3}{4}$ of the rotation path of the platform, power is drawn from the wind, while for the rest of the path, the blades are adjusted so that they offer minimal resistance to the wind. The blades are controlled by means of a central transmission mechanism with a shared servomotor.

[0006] The document U.S. Pat. No. 4,410,806 A describes a vertical wind turbine with a rotating structure, which includes a series of rotatable vertical blades positions of which are controlled to maintain a constant rotation speed of the rotating structure, when wind speed is sufficient. A microprocessor controller processes information about the wind speed, wind direction, and rotation speed of the rotating structure and produces an electrical signal for

adjusting the blade position. The control system for the wind turbine includes electrical blade actuators that modulate the blades of the rotating structure. Blade modulation controls the angle of attack, which in turn determines the rotation speed of the rotor. A wind speed sensor provides data for starting or stopping the system and a wind direction sensor is used to keep the blade flip region at 90° and 270° relative to the wind direction. The control system is designed to maintain constant rotation speed at wind speeds of between 19 and 40 miles per hour.

[0007] The document U.S. Pat. No. 4,494,007 A discloses a vertical wind turbine, wherein the orientation of the blades revolving around a common central axis is controlled by a tail vane by means of a shared mechanism during their rotation around the central axis such that if the wind speed changes, the rotation position of the blades is changed.

[0008] The document U.S. Pat. No. 4,609,827 A describes a vertical wind turbine with rotor vanes that are airfoil-shaped. A positive and synchronous vane orientation system is controlled by a mechanism located exterior to its rotor.

[0009] Finally, in “Vertical Axis Wind Turbine with Individual Active Blade Pitch Control”; College of Mechanical and Electrical Engineering; Harbin Engineering University; Harbin, China; 2012 IEEE, Lixun Zhang, Yingbin Liang, Erxiao Li, Song Zhang, and Jian Guo describe a vertical wind turbine with individually active blade control, wherein servomotors are mounted on the arms supporting the blades and each by means of a belt drive, are intended to perform a pitch angle adjustment of the blades in accordance with their azimuth angle.

[0010] In “H-Darrieus Wind Turbine with Blade Pitch Control”; International Stud of Rotating Machinery, vol. 2009, Ion Paraschivoiu, Octavian Trifu, and F. Saeed address a variation of the pitch angle of the blades of a vertical wind turbine in accordance with the azimuth angle in order to maximize a torque output by the rotor of the vertical wind turbine.

[0011] In “A Straight-bladed Variable-pitch VAWT Concept for Improved Power Generation”; ASME 2003, Wind Energy Symposium, vol. 2003, pp. 146-154; January 2003, Y. Staelens, F. Saeed, and I. Paraschivoiu describe experiments for improving the performance of vertical wind turbines with blades, a pitch angle of which is variable. At each blade, the tangential force should be optimized by varying the pitch angle in the respective rotational position in accordance with the azimuth angle. Different blade profiles are studied.

[0012] In vertical wind turbines that are known from the prior art, it is disadvantageous that the blade control and blade drive do not enable a satisfactory energy yield and reasonable efficiency. In addition, the blade drive consumes too much energy and is susceptible to wear, which minimizes the efficiency and service life of the systems in an unsatisfactory way.

DISCLOSURE OF THE INVENTION

[0013] One object of the invention is to avoid at least some of the disadvantages of the prior art. In particular, the efficiency and service life of vertical wind turbines should be improved in comparison to the prior art. This object is achieved by the features of the independent claims.

[0014] In particular, the disadvantages of the prior art are overcome by means of a vertical wind turbine according to the invention with a plurality of vertical blades, which are

each supported such that they are motor-driven pivotable around a respective blade rotation axis independently of one another, and are rotatable on a common circular path around a vertical rotor rotation axis, wherein the blades are each held fastened to at least one pitch motor for motor-driven pivoting of the blades around their respective blade rotation axis.

[0015] In other words, the blades are each supported directly at the pitch motor. For example, the blades are each fastened to a respective vertical blade axis independently of one another, can be motor-driven to pivot around a respective blade rotation axis, and are supported so that they are able to rotate on a common circular path around a vertical rotor rotation axis; wherein the blade axes are each provided with at least one pitch motor for motor-driven pivoting of the blades, a motor shaft of which extends concentrically to the respective blade rotation axis.

[0016] With a method according to the invention, the disadvantages from the prior art are overcome by predetermining angular positions of vertical blades of the vertical wind turbine, which are supported such that they are rotatable around a respective vertical rotor rotation axis, and are motor-driven pivotable around a respective blade rotation axis independently of one another, wherein the angular positions of the blades are each predetermined by means of at least one pitch motor at least partially supporting the respective blade.

[0017] In other words, a pitch motor carrying the respective blade predetermines the angular position. The blades can each be carried exclusively at a single pitch motor, which provides mechanical certainty and thus a very advantageous vibration behavior to the entire wind turbine, considered as a system. It is thus possible for a vibration frequency of the vertical wind turbine during operation to always be kept below its resonant frequency, which helps to minimize dynamic loads on the wind turbine resulting from any vibrations and thus makes it possible to increase the maintenance interval lengths and service life thereof. For example, angular positions are predetermined for vertical blades of the vertical wind turbine that are driven around a respective vertical blade axis, the angular positions being continuously controlled by means of a direct drive of each of the blades by means of a respective pitch motor positioned concentrically to the blade axis.

[0018] The solution according to the invention has the advantage that it enables a very precise and energy-saving driving of the blades in accordance with pitch cam disks. The angular positions of the blades can be optimally set without delay and taking into consideration the varying system conditions (wind speed, wind direction, rotor rotation, power output, etc.) at a power consumption of the pitch motors of at most less than 10% to preferably less than 0.5%, for example 0.3%, of a generator output power of the vertical wind turbine.

[0019] By means of the solution according to the invention, it is possible to satisfy an existing requirement for vertical wind turbines of selecting the tip speed ratio A such that the angle between the incidence vector of the wind and the rotor blade chord (the so-called angle of attack) does not exceed a value at which the flow separates from the profile. The tip speed ratio A is defined by the ratio of the rotational speed of the rotor to the wind speed. Up to a nominal speed, vertical wind turbines according to the invention have a tip speed ratio λ of 2 to 2.5, preferably approx. 2.3, which is

determined by a circumferential speed of the blades of approx. 27.6 m/s at a wind speed of 12 m/s during nominal operation ($\lambda=27.6/12=2.3$).

[0020] The higher the tip speed ratio, the smaller the angle of attack relative to the profile. In reality, this means that vertical wind turbines are generally operated with tip speed ratios A of greater than 4. This necessarily results in high rotation speeds or high rotor radii in order to achieve the circumferential speed that is required for the tip speed ratio. High circumferential speeds in turn increase parasitic losses, which are caused by the aerodynamic drag of rotor arms and guys, for example. Such losses influence the energy output by the cube of the circumferential speed.

[0021] A continuous pitch control of the blades according to the invention helps keep the tip speed ratio as optimally constant as possible and compensates for negative effects of strongly and quickly changing wind conditions. Thereby, an optimal energy yield in partial load operation is achieved. Consequently, vertical wind turbines according to the invention make it possible to utilize wind energy in an economically efficient way even in locations with widely varying wind conditions.

[0022] In addition, high circumferential speeds contribute to a high noise emission and to high centrifugal accelerations. Through a continuous control of the rotor blades of the kind that is implemented in vertical wind turbines according to the invention, in principle any tip speed ratio can be used with the optimal pitch angle. In other words, a stall can be avoided even with low tip speed ratios. It is thus possible for the optimal operating range to be evaluated in a way that takes into account parasitic resistances.

[0023] Numerical simulations with a DMS model (double multiple stream-tube) for vertical wind turbines according to the invention in accordance with an exemplary embodiment show a maximum energy yield at a tip speed ratio of for example $\lambda=2.3$. Including geometrical dimensions of vertical wind turbines according to the invention, this yields circumferential speeds of approx. 100 km/h, which leads to significantly lower noise emissions than in conventional horizontal wind turbines and vertical wind turbines that are known from the prior art because the circumferential speed affects the acoustic power to the sixth power.

[0024] Furthermore, in connection with a wind farm efficiency of vertical wind turbines, which is approx. 20% and is thus more advantageous than a wind farm efficiency of horizontal wind turbines, which is approx. 10%, vertical wind turbines that are configured and operated according to the invention can be operated more efficiently and economically than horizontal wind turbines, particularly in wind farms, or more precisely stated, can be operated at twice the wind farm efficiency. In addition, unlike horizontal wind turbines, vertical wind turbines according to the invention can be operated in a power range of for example 750 kW generator output power, which is ideal for the rapidly growing sector of the "distributed wind market" in which environmentally friendly and socially responsible solutions are very relevant (populated areas, logistically challenging wind locations).

[0025] In addition, vertical wind turbines according to the invention have an advantageous wake behavior. Since the blades are held in their angular position in a variable manner by means of the pitch motors, which helps prevent stalls, this minimizes turbulence in the wake. A resulting low turbulence intensity in the wake allows for shorter distances

between vertical wind turbines according to the invention and thus further improves their wind farm efficiency.

[0026] As a result of relatively small and/or lightweight parts and components, in contrast to horizontal wind turbines, it is possible to set up vertical wind turbines without heavy transport even in difficult terrain. In normal terrain, all of the components of a vertical wind turbine (even heavy ones) can be transported using a conventional truck without special transport. In mountainous terrain, the components can be transported by a light helicopter and the few heavy components can be transported by an off-road vehicle.

[0027] Vertical wind turbines according to the invention can be installed using a self-assembly system without the use of additional heavy-duty cranes. The self-assembly system includes a central crane that grows along with a tower or tower system of a vertical wind turbine according to the invention and heavy-duty lifting rollers that are positioned in the tower and/or on arms of the vertical wind turbine. All of the heavy main components can be hoisted to their respective installation heights by means of a mobile cable winch on the ground and deflection sheaves in the tower.

[0028] For repair-related disassembly and assembly work on the rotor blades and blade bearings, only a small crane is temporarily positioned at the very top of the respective rotor arm with the aid of a helicopter. For simple maintenance and repair work on the rotor, the rotor is locked in position by positive-fit engagement. In the case of rotor bearing damage, generator damage, or transmission damage, disassembling the rotor does not require removal thereof. When stopped, it is mechanically secured to a lifting device on the tower and a thrust bearing supporting the rotor is thus freed of the rotor load. This securing can withstand gale forces. The components possibly requiring repair can then be lowered without a crane, using a cable winch and deflection sheaves in the tower and can be directly loaded onto a truck at the bottom.

[0029] Finally, with regard to their environmental impact, the vertical wind turbines according to the invention are also advantageous in that the silhouette of the vertically oriented rotor is more visible to birds and bats than a horizontally rotating three-blade rotor. In addition, at a maximum of 100 km/h, the rotor blade speeds are significantly lower than with horizontal wind turbines in which blade tip speeds of 300 to 400 km/h occur. In contrast to horizontal wind turbines, the relatively slowly rotating rotor system of the vertical wind turbine according to the invention has a calm shadowing and a small ice throwing range. The appearance of a vertical wind turbine according to the invention, with its predominantly vertical lines, integrates well into the surrounding landscape.

[0030] The solution according to the invention can be arbitrarily enhanced and further improved by means of the following embodiments, which are each advantageous in and by themselves; a person skilled in the art will easily recognize in a clear and unambiguous way that apparatus features of a vertical wind turbine according to the invention constitute the basis for corresponding steps of a method according to the invention and vice versa. The disclosure content of the applicant's international patent application numbers PCT/IB2017/053972 and PCT/IB2017/053974 is fully incorporated into the present disclosure by reference.

[0031] According to a first further embodiment of a vertical wind turbine according to the invention, the pitch motor is embodied as a torque motor with at least one rotor ring

that is rotationally coupled to the respective blade. For this purpose, the pitch motor can be embodied as a torque motor with at least one rotor that is torsionally rigidly coupled to the blade axis. For example, the torque motor can be embodied as a permanently excited brushless DC motor with an internal-rotor design. The rotor, which is thus surrounded along its outer circumference by a stator of the pitch motor, can be torsionally rigidly coupled in a simple and effective way to a motor shaft of the pitch motor with the aid of a clamping set.

[0032] According to another embodiment, the rotor ring rests against the outer circumference of a motor shaft of the pitch motor. Thus, a torque produced by the pitch motor can be transmitted directly to the motor shaft and thus to the blade. In other words, the blade is advantageously driven directly by the motor. For example, the blade axes are supported on motor bearings in the pitch motor. In other words, the blades can be secured in rotary fashion in the pitch motor. For example, the bearing can be implemented by means of tapered roller bearings, rolling bearings, or conical roller bearings, which are positioned in an axially prestressed fashion between the blade axis and motor on the one hand and the stator on the other in order to absorb both axial forces and radial forces. This enables a precise positioning of the blade axes with a long service life and a highly efficient driving of the blade axes by means of the pitch motor with low friction losses.

[0033] According to another embodiment, the blades are borne supported on motor bearings in the pitch motor. Consequently, both horizontal forces and vertical forces originating from the blades, including a weight force of the blades, can be absorbed in the motor bearings. For example, the motor bearings are positioned in a bearing receiving chamber that is sealed up in against the surroundings of the vertical wind turbine with the aid of sealing elements. The bearing receiving chamber can contain lubricant such as grease for lubricating the motor bearings. Preferably, the bearing receptacle is filled with the lubricant, which is replaced or refilled every 5 years, depending on the requirements. This achieves an effective lubrication of the motor bearings, which helps to further maximize the service life of a vertical wind turbine according to the invention.

[0034] The bearing receiving chamber can in turn be sealed up relative to a motor interior with the aid of additional sealing elements so that the motor interior is protected from harmful environmental influences in an essentially hermetically sealed way. The motor interior can be at least partially formed by a motor housing and/or enclosed by it.

[0035] An expansion or compensation vessel can be connected to the hermetically sealed motor interior in a fluid-conducting manner via at least one fluid line and can constitute a changeable expansion or compensation volume in order to compensate for temperature-induced volume changes of fluids, in particular air, contained in open spaces inside the motor chamber. To avoid the presence of open spaces in the motor interior, space-filling elements can be positioned in the motor chamber, which can be formed of foam material, for example. The expansion vessel and space-filling elements on the one hand help to prevent humidity from condensing in the motor interior. On the other hand, expansion vessel and space-filling elements prevent

bearing lubricant and/or motor lubricant such as grease from being displaced or escaping when pressure fluctuations occur.

[0036] According to another embodiment, the blades include an upper blade section and a lower blade section and the pitch motor is positioned between the upper and lower blade sections. The pitch motor can thus support both blade sections, with the upper blade section extending upwardly away from the pitch motor and the lower blade section extending downwardly. Consequently, torques or positioning forces that are produced by the pitch motor and act on the blades can be introduced into the blades as symmetrically as possible in relation to the longitudinal span of the blades in the vertical direction.

[0037] Alternatively, or additionally, the blades can be supported rotatable around their blade rotation axis at at least one additional bearing point arranged at a distance from the pitch motor. In this way, the pitch motor can, for example, be positioned between two additional bearing points. There are thus two respective blade sections per blade, namely a blade section between the upper bearing point and the pitch motor and a blade section between the pitch motor and the lower bearing point.

[0038] Preferably, a bearing unit is positioned at each of the outer ends of the blade pointing away from the pitch motor. The bearing unit includes a housing, two roller bearings, and a hollow shaft that connects the rotor blades of the blades to one another. At the additional bearing points, spherical roller bearings can be used, which absorb high radial forces occurring mainly at the blade ends and help to stiffen the rotor system as a whole. By contrast, the motor bearings can include, for example, two axially prestressed conical roller bearings that absorb the entire weight force of the blades.

[0039] According to another embodiment, the blades are flange-mounted to the pitch motor. To that end, a flange section of the blade can be fastened directly to the motor shaft or to the rotor of the pitch motor. Torques or positioning forces that are produced by the pitch motor can thus be transmitted directly to the blades. Alternatively, or additionally, the blades or blade axes can each include a vane axis section in the region of a vane of the blade and a transition section positioned between the vane axis section and the motor shaft. The transition section and motor shaft can, for example, be integrally formed of a single piece of metal. The transition section allows for an optimal connection between the motor shaft and the vane axis section. The transition section can taper in the direction extending away from the motor shaft. For example, the transition section can be shaped in the form of a stud. An outer diameter of the motor shaft can be greater than an inner diameter of the vane axis section. The transition section thus helps to overcome dimensional differences between the motor shaft and the vane axis section and to connect them to each other in a precisely fitting way.

[0040] According to another embodiment, the pitch motor includes at least one rotary position transducer for determining a rotation position of the blade. The rotary position transducer preferably includes an absolute position transducer and a relative position transducer. For example, the absolute position transducer includes a magnetic ring or strip, which extends along the outer circumference of the motor shaft and has increments of different magnetization with irregular distances between one another along the outer

circumference or more precisely stated, irregular lengths. For example, the relative position transducer includes a magnetic ring or strip, which extends along the outer circumference of the motor shaft and has increments of different magnetization with regular, i.e. equal distances between one another along the outer circumference or more precisely stated, regular or uniform lengths.

[0041] According to another embodiment, the pitch motors each have a motor housing at which a rotor arm is fastened that connects the blades to a rotor hub of the vertical wind turbine. In other words, the pitch motors can thus each have a motor housing to which a blade mount is mounted that connects the blades to a rotor hub of the vertical wind turbine. The blade mount can alternatively or additionally include a plurality of struts, for example. At least one of these struts can be directly connected to the pitch motor in order to secure the respective blade.

[0042] According to another embodiment, the rotor arm is flange mounted to the motor housing. To that end, the motor housing can be provided with a motor flange onto which the arm is mounted. The motor housing has at least two housing shells, for example an upper and lower housing shell. Both of the housing shells can have a respective flange half of the motor flange formed onto them.

[0043] Alternatively, or additionally, the blade mount can have a plurality of struts, with at least one strut respectively flange-mounted to the motor housing. On the outside of the motor housing in the region of an outer circumference of the stator, each strut can be advantageously flange-mounted to the end of the pitch motor. This permits a weight-reducing, highly stable design of the rotor as a whole since the pitch motor simultaneously functions as a driving point, bearing point, and connecting point between the blade mount and the blade.

[0044] According to another embodiment, a stator ring of the pitch motor is positioned between two flange halves of a mounting collar of the motor housing and/or between an upper shell and lower shell of a casing that at least partially cases-in the pitch motor. The pitch motor is thus preferably covered with a casing that is shaped in accordance with aerodynamic aspects. On the one hand, the casing helps to reduce an aerodynamic drag of the pitch motor. On the other hand, the casing helps to avoid or at least reduce the presence of a gap between the pitch motor and the vanes and thus the pressure losses that occur at such a gap between the two lateral surfaces of the blade at the end of the respective vane oriented toward the pitch motor. It is thus possible to further increase the efficiency of a vertical wind turbine according to the invention.

[0045] Alternatively, or additionally, the motor housing can include support ribs, which extend radially to the motor shaft and connect a bearing seat of the pitch motor on the outer circumference to a wall of the pitch motor housing facing in the axial direction. Support ribs of this kind help to reliably transmit forces that the motor shaft introduces onto the motor housing via the bearing points to a connection point of the blade mount on the motor housing, for example the above-mentioned motor flange. The rigidity of the motor housing is increased while its weight is kept as low as possible.

[0046] According to another embodiment, the casing forms at least one intake socket and at least one discharge opening in order to convey cooling air between the intake socket and the discharge opening along at least part of a

cooling body that is mounted on the stator ring. An air duct formed between the intake socket and the discharge opening helps to prevent stalls from occurring in the cooling air conveyed along the cooling body and thus to prevent stalls from producing wakes in the cooling air. It is thus possible to increase the cooling capacity of the cooling air on the cooling body, which helps to avoid an overheating of the pitch motor.

[0047] As already mentioned above, the pitch motor is preferably cased-in with a casing that is designed in accordance with aerodynamic aspects. The casing can minimize an aerodynamic drag caused by the pitch motor, which helps to further increase the efficiency of a vertical wind turbine according to the invention. In addition, the casing helps to minimize any intermediate spaces between the blade sections and between the blade sections and the motor and thus to prevent a pressure compensation in the intermediate spaces. In a similar way, casings or covers can also be provided in the region of the additional bearing points or bearing units between the blade sections in order to counteract pressure compensation and the efficiency loss that this entails.

[0048] According to another embodiment, the vertical wind turbine has a transmission that couples a rotor of the vertical wind turbine, which is able to rotate around the rotor rotation axis, to a generator of the vertical wind turbine; wherein at least one transmission stage of the transmission is embodied as a planetary gear or planetary gear stage. For example, the transmission can include at least one planetary gear and an additional spur gear pair. Preferably, the transmission has two planetary gear stages, which are positioned one above the other in the axial direction of the rotor rotation axis. The transmission therefore has a compact design with the greatest possible efficiency and longevity.

[0049] According to another embodiment, at least one planet gear of the planetary gear or planetary gear stage is connected by means of a flexible pin to a strut of the planetary gear or planetary gear stage. Such a flexible pin enables minimal deflections of the planet gear. Preferably all of the planet gears are supported on flexible pins. Flexible pins help to minimize loads on the transmission due to uneven loads of the planet gears and their tooth flanks. The flexible pins ensure a uniform distribution of the transmission load among the planet gears. The planet gears supported on the flexible pins can, so to speak, divide the load among themselves. It is thus possible to further increase the maintenance interval lengths and service life of a vertical wind turbine according to the invention.

[0050] By contrast, with a rigid support of the planet gears, unilateral loads on certain planet gears can occur, which not only increases wear on these planet gears, but also requires the transmission as a whole to be dimensioned larger than is the case with flexible pins because the rigidly supported planet gears are subjected to higher loads than the planet gears that are supported on flexible pins. The flexible pins therefore make it possible to reduce the size of the transmission as a whole, which helps to reduce material consumption, production complexity, and costs.

[0051] According to another embodiment, the vertical wind turbine has a control device for control of the pitch motors, that is connected in a signal-transmitting manner to the pitch motors and to at least one wind speed sensor and/or at least one wind direction sensor. The control device calculates a set-point angle of the blades for each pitch

motor, for example cyclically, and transmits it via a communication device to a control section of an inverter system, which in addition to the control section, also has a supply section for each pitch motor. The control section carries out a position control of the blades in order to set a desired angular position in accordance with the set-point angle. To that end, the power section continuously inverts an electric current of for example $150 A_{RSM}$ and briefly outputs a peak current of $210 A_{RMS}$ in order to achieve a maximum torque of the pitch motors. The control device in this case monitors a precision of the blade adjustment and a state of the drive control and is able to influence them.

[0052] According to another embodiment, the at least one wind speed sensor and/or the at least one wind direction sensor is arranged in the region of at least one of the pitch motors. For example, the at least one wind speed sensor and/or the at least one wind direction sensor can be mounted on a rod, which is fastened to the pitch motor or in the region of the pitch motor and protrudes beyond an outer edge of the blade. In particular, the at least one wind speed sensor and/or the at least one wind direction sensor can be mounted on a distal end of the rod oriented away from the blade. As a result, the at least one wind speed sensor and/or the at least one wind direction sensor is preferably situated outside of an influence region of the blade in which air flow changes and turbulence caused by the blade could occur. Alternatively, or additionally, sensors such as a wind speed sensor and/or wind direction sensor as well as other signaling and measuring means can be positioned on a mast positioned centrally on the rotor hub and preferably protruding in the vertical direction beyond an upper end of the blades.

[0053] Alternatively, or additionally, at least one wind speed sensor and/or wind direction sensor can be positioned in the region of the motor hub. For example, the number of wind speed sensors and/or wind direction sensors used can coincide with the respective number of blades and arms of the vertical wind turbine. Wind speed sensors and/or wind direction sensors in the region of the motor hub can be fastened to ends of rods extending away from the rotor hub. The wind speed sensors and/or wind direction sensors in the region of the motor hub can preferably be positioned between the blades or their arms, in other words offset from the blades, in order to avoid a wind shadowing of the wind speed sensors and/or wind direction sensors in the region of the motor hub by the blades.

[0054] According to another embodiment, a vertical wind turbine according to the invention is provided in the form of a kit. As has already been mentioned above, such a kit, which essentially includes all of the components and parts of the vertical wind turbine and tools for the installation thereof, such as cranes, winches, and the like, makes it possible to install a vertical wind turbine according to the invention in sites that are not accessible or hardly accessible for horizontal wind turbines. A preparation of a vertical wind turbine according to the invention in the form of a kit also helps to ensure that all of the components, parts, and tools that are required for the installation, operation, and maintenance of the vertical wind turbine stem from verified supply sources and satisfy desired safety and quality requirements.

[0055] According to another embodiment, a method according to the invention for operating a vertical wind turbine can be improved by predetermining the angular positions by means of pitch cam disks. Thereby, set-point values for adjusting the angular position are provided for

essentially every azimuth angle. Different pitch cam disks can be provided for different wind speeds.

[0056] According to another embodiment of a method according to the invention, a wind speed, wind direction, and rotor rotation of a vertical wind turbine rotor comprising the blades are included in the continuous control. It is thus possible for a vertical wind turbine according to the invention to be operated with the smallest possible set-point deviations of the angular positions and thus in an extremely efficient way.

[0057] Further, the disadvantages from the prior art are overcome by means of a vertical wind turbine according to the invention with a plurality of vertical blades, which are each fastened to a respective vertical blade axis such that they are pivotable independently of one another around a respective blade rotation axis, and are supported rotatable on a common circular path around a vertical rotor rotation axis, wherein the vertical wind turbine is configured to control a pitch angle of the blades at least in a partial load mode of the vertical wind turbine, such that the blades rotate with an essentially constant tip speed ratio λ .

[0058] With a method according to the invention, the disadvantages of the prior art are further overcome by predetermining pitch angles of vertical blades of the vertical wind turbine that are driven around a respective vertical blade axis; wherein at least in a partial load mode of the vertical wind turbine, the pitch angles are controlled such that the blades rotate with an essentially constant tip speed ratio λ .

[0059] According to a further embodiment of a vertical wind turbine according to the invention, the vertical wind turbine is designed to operate in the partial load mode in a range of wind speeds that at least partially lie between 3 and 12 m/s. Such a partial load range is suitable for both inland and coastal sites and ensures a high energy yield as well as a relatively large number of full load hours per year. With a low starting speed of 3 m/s, the partial load range also ensures that a vertical wind turbine according to the invention is able to supply power even in a light wind.

[0060] According to another embodiment, the constant tip speed ratio amounts to between 2 and 2.6, preferably between 2.2 and 2.4, and most preferably essentially 2.3. A value range of this kind for the constant tip speed ratio results in relatively low rotation speeds of the rotor and therefore relatively low blade speeds. As a result, a vertical wind turbine according to the invention, as already mentioned above, can be operated with advantageously low environmental influences.

[0061] According to another embodiment, the vertical wind turbine is configured to control the pitch angle so that in a nominal operation mode of the vertical wind turbine, the blades rotate with a variable tip speed ratio. A pitch control according to the invention can thus contribute to limiting the output of a vertical wind turbine according to the invention. This prevents damage to the material of a vertical wind turbine according to the invention and thus reduces wear on it and extends its service life.

[0062] According to another embodiment, the vertical wind turbine is configured to control the pitch angle so that in the nominal operation mode, the blades rotate at an essentially constant nominal speed. As a result, the rotor rotates in a nominal speed range. This helps to avoid load peaks on components of the vertical wind turbine and

therefore helps to prevent damage to the material of a vertical wind turbine, reduce wear, and increase service life.

[0063] According to another embodiment, at a first cut-out wind speed v_3 of the vertical wind turbine, the variable tip speed ratio λ amounts to between 1 and 1.8, preferably between 1.3 and 1.5, most preferably essentially 1.38. For example, the cut-out wind speed v_3 can be in the range of 20 m/s. Particularly at such a relatively high wind speed, the relatively low value range of the variable tip speed ratio helps to keep the circumferential speed of the blades as low as possible and thus to ensure that a vertical wind turbine according to the invention is very environmentally friendly.

[0064] According to another embodiment, the vertical wind turbine is configured to control the pitch angle in a start-up mode so that starting from a resistance mode with tip speed ratios of $\lambda \leq 1$, the blades transition into a fast mode with tip speed ratios of $\lambda > 1$. It is thus possible, particularly when starting the vertical wind turbine from a rotor standstill, to make optimal use of the energy absorbed by the blades based on their wind resistance and to maximize a start-up torque on the rotor. As soon as the rotor has reached a certain rotation speed, a smooth transition to the fast mode of the blades can be carried out. This helps to shorten the overall start-up times of a vertical wind turbine according to the invention and thus helps to increase the energy yield.

[0065] According to another embodiment, the control of the pitch angle is based on at least one cam disk, which determines the pitch angle in an essentially continuous manner for an entire rotation of the rotor. A continuous determination of the pitch angle enables the gentlest, smoothest possible control and regulation of a vertical wind turbine according to the invention with the least number of parameter jumps of the kind that can occur when pitch angles are predetermined in rough, discrete steps. Different cam disks can be specified for different wind speeds. Each of the cam disks can be optimized with regard to the respective wind speed and with regard to the resulting flow conditions at the blades.

[0066] According to another embodiment, a maximum value of the pitch angle for windward positions of the blade is generally greater than for leeward positions of the blade, with respective regard to the rotor rotation axis. In other words, for azimuth angles of less than 180° , the pitch angle can generally be less than for azimuth angles of between 180° and 360° . The pitch control thus takes into account the respective flow conditions at the blades as a function of the azimuth angle. In particular, this therefore takes into account leeward flow effects caused by the rotor and blades themselves such as turbulence and wakes, making it possible to further improve the energy yield of a vertical wind turbine according to the invention.

[0067] According to another embodiment, for wind speeds in the range of a nominal wind speed, at an azimuth angle of 0° measured from a zero line oriented perpendicular to the wind direction, the pitch angle is less than zero. In other words, the blade is thus rotated into the wind with a pitch angle of less than 0° or more precisely stated, changes from leeward to windward. This contributes to improved dynamics of a vertical wind turbine according to the invention and thus to an increased energy yield.

[0068] According to another embodiment, at least for wind speeds in the vicinity of the nominal wind speed, with azimuth angles of 0° to 90° measured from a zero line oriented perpendicularly to the wind direction, there is a

local maximum of the pitch angle. Thereby, the dynamics and energy yield of a wind turbine according to the invention are further improved.

[0069] According to another embodiment, the vertical wind turbine has at least one wind speed sensor and/or at least one wind direction sensor, which is positioned on at least one of the blades and is connected in a signal-transmitting manner to a control device for determining a setpoint of the pitch angle. As a result, wind speed and/or wind direction as relevant measurement variables can be advantageously determined at the blade and, can be determined as close as possible to a closed loop control system for adjusting the pitch angle, which system includes the blade and for example a pitch drive mounted on it or positioned in the vicinity thereof. This promotes a pitch control that is as precise and error-free as possible.

[0070] According to another embodiment, at wind speeds from still air up to a further cut-off speed of the vertical wind turbine, an amount of a positioning error in the control of the pitch angle is essentially always less than 5°, preferably less than 3°, most preferably less than 1.5°. By means of such low positioning errors it is possible on the one hand to increase the energy yield of a vertical wind turbine according to the invention. On the other hand, this also makes it possible to minimize undesirable incorrect loading as well as vibrations and the like of the vertical wind turbine because largely without deviation, the rotation of the blades corresponds to a predetermined set-point value or set-point pitch angle.

DESCRIPTION OF FIGURES

[0071] Exemplary embodiments of the invention will be described below based on the following figures. In the drawings:

[0072] FIG. 1 shows a schematic perspective view of a vertical wind turbine according to the invention;

[0073] FIG. 2 shows a schematic side view of a vertical wind turbine according to the invention;

[0074] FIG. 3 shows a schematic top view of a vertical wind turbine according to the invention;

[0075] FIG. 4 shows a detail IV indicated in FIG. 2 of a blade of a vertical wind turbine according to the invention;

[0076] FIG. 5 shows a detail V indicated in FIG. 4 of a blade of a vertical wind turbine according to the invention with a pitch motor according to the invention in a schematic cross-sectional view along a rotation axis of the blade;

[0077] FIG. 6 shows a schematic perspective view of aerodynamically cased-in pitch motors of a vertical wind turbine according to the invention;

[0078] FIG. 7 shows a schematic perspective view of a pitch motor together with blades mounted on it, particularly showing a motor flange of the pitch motor for fastening the pitch motor together with the blades to an arm of a rotor of a vertical wind turbine according to the invention;

[0079] FIG. 8 shows a schematic partial cross-sectional view of a pitch motor according to the invention;

[0080] FIG. 9 shows a schematic cross-sectional view of a drive train of a vertical wind turbine according to the invention along a drive shaft of the drive train;

[0081] FIG. 10 shows a schematic perspective view of a first embodiment according to the invention of a hub connection of a vertical wind turbine according to the invention;

[0082] FIG. 11 shows a schematic front view of a section of an arm of a rotor of a vertical wind turbine according to the invention;

[0083] FIG. 12 shows a schematic side view of the section shown in FIG. 11 of an arm of a rotor of a vertical wind turbine according to the invention;

[0084] FIG. 13 shows a schematic cross-sectional view of the section shown in FIGS. 11 and 12 of an arm of a rotor of a vertical wind turbine according to the invention along the cross-sectional line A-A shown in FIG. 12;

[0085] FIG. 14 shows a schematic top view of the section shown in FIGS. 11 to 13 of an arm of a rotor of a vertical wind turbine according to the invention;

[0086] FIG. 15 shows a schematic top view of a vertical wind turbine according to the invention during operation to illustrate angular positions and force conditions at blades of the vertical wind turbine;

[0087] FIG. 16 shows a schematic diagram to illustrate the function of a control device according to the invention belonging to a vertical wind turbine according to the invention;

[0088] FIG. 17 shows a schematic diagram with a sample torque characteristic curve of a pitch motor according to the invention for a vertical wind turbine according to the invention;

[0089] FIG. 18 shows a schematic diagram with sample cam disks for controlling a pitch motor for a vertical wind turbine according to the invention;

[0090] FIG. 19 shows a schematic perspective view of a test bench for determining a positioning error of a pitch motor of a vertical wind turbine according to the invention;

[0091] FIG. 20 shows a schematic diagram of a positioning error of a pitch motor according to the invention, which has been determined by means of the test bench shown in FIG. 19, over a plurality of control cycles;

[0092] FIG. 21 shows a schematic diagram of a positioning error of a pitch motor according to the invention over one control cycle at a; and

[0093] FIG. 22 shows a schematic diagram of a positioning error of a pitch motor according to the invention over one control cycle at a cut-out wind speed.

IMPLEMENTATION OF THE INVENTION

[0094] For better comprehension of the present invention, reference is made to the drawings in the following. The drawings merely show exemplary embodiments of the subject-matter of the invention; as described above, features can be arbitrarily combined with one another or also omitted, depending on the respective requirements.

[0095] FIG. 1 shows a schematic perspective view of a vertical wind turbine according to the invention 1. The vertical wind turbine 1 extends along a longitudinal direction X, a transverse direction Y, and a vertical direction Z, which together define a Cartesian coordinate system. The vertical wind turbine 1 includes a rotor 2, a nacelle 3, a tower system 4, footings 5, and a container-like switchgear box 6.

[0096] The rotor 2 includes a plurality of vertical blades 7, which are fastened by means of a blade mount 8 to a rotor hub 9, which is supported in the nacelle 3 so that it is able to rotate around a rotor rotation axis C₂ that is vertically oriented, i.e. extends parallel to the vertical direction Z. The blade mount 8 includes rotor arms 10, which extend between

the blades 7 and the rotor hub 9. A signaling and/or measuring unit 11 is positioned on the rotor hub 9 concentric to the rotor rotation axis C_2 .

[0097] As a rule, the nacelle 3 is positioned at the top of the tower system 4, is cased-in in a sound-absorbing way, and contains a drive train of the vertical wind turbine 1 (generator, rotor bearing system, transmission, mechanical brake, and cooling/lubricating system, see FIG. 9). The tower system 4 is preferably embodied as a lattice mast tower. The footings 5 are preferably concrete footings, which absorb the load of the tower system 4, the nacelle 3, and the rotor 2. Other components such as electrical transformers, switch components, and a control device (see FIG. 16) of the vertical wind turbine 1 are preferably accommodated in the switchgear box 6.

[0098] The blades 7 are supported so that they are able to rotate around a blade rotation axis C_7 , which likewise extends essentially parallel to the vertical direction Z. For the rotation of each of the blades 7 around its respective blade rotation axis C_7 , they are each provided with at least one pitch drive 12. At least one of the rotor arms 10 is connected to the pitch drive 12, which can thus help absorb a load of the blade 7.

[0099] FIG. 2 shows a schematic front view of the vertical wind turbine 1. Here, it becomes clear that the blades 7 have a plurality of blade sections 13, namely an upper end section 13a, an upper middle section 13b, a lower middle section 13c, and a lower end section 13d. The upper end section 13a and upper middle section 13b together constitute an upper blade section 13e. The lower middle section 13c and lower end section 13d together constitute a lower blade section 13f. The pitch drive 12 is positioned between the upper middle section 13b and lower middle section 13c, i.e. between the upper blade section 13e and lower blade section 13f. Between the upper end section 13a and the middle end section 13b as well as between the lower middle section 13c and the lower end section 13d, respective cross-sectional change of a profile of the blades 7 is provided, respectively.

[0100] At bearing points 14 between the upper blade section 13e and lower blade section 13f, the blades 7 are each connected by means of one of the arms 10 to the rotor hub 9, which is designed to transmit forces acting radially and axially relative to the rotor rotation axis C_2 , said forces therefore acting essentially in a horizontal plane, which is defined parallel to the longitudinal direction X and transverse direction Y, and along the vertical direction Z. At the pitch drive 12, between the upper middle section 13b and lower middle section 13c of the blades 7, forces are absorbed, which act both radially and parallel to the rotor rotation axis C_2 . Consequently, the entire weight load of the rotor 2 is absorbed at the pitch drive 12.

[0101] Further, it is illustrated in FIG. 2 that the rotor hub 9 and the tower system 4 are each embodied as a tubular lattice structure. At the top of the tower system 4 embodied as a lattice mast tower, it tapers in the direction toward the nacelle 3 and at this location, absorbs all of the static and dynamic loads generated by the rotor 2. At the bottom of the tower system 4, the loads are transferred to the ground by means of the footings 5. The nacelle 3 can be accessed by means of a ladder (see FIG. 10).

[0102] A maximum width B_4 of the tower system 4 measured parallel to the longitudinal direction X at the footings 5 is 22 m, for example. A length L_7 of the blades 7 measured parallel to the vertical direction Z is 54 m, for example. An

overall height of the vertical wind turbine 1 measured to include a height of the footings extending above the ground is 105 m without the signaling and/or measuring mast 11, for example.

[0103] FIG. 3 shows a schematic top view of the vertical wind turbine 1. Here, it becomes clear that the blades 7 have a blade profile and move on a circular path K around the rotor rotation axis C_2 . A diameter D_K of the circular path K is 32 m, for example, and approximately corresponds to a maximum diameter of the tower system 4.

[0104] FIG. 4 a detail IV indicated in FIG. 2 of one of the blades 7 of the vertical wind turbine 1. The blade 7 has vanes 19. Between the upper middle section 13b and lower middle section 13c, i.e. between the upper blade section 13e and lower blade section 13f, the blade 7 is supported in the pitch drive 12 on a motor shaft 25 of the pitch drive 12. Together with the motor shaft 25, the vanes 19 form a blade axis 26, which passes through the entire length of the blade 7 and the vanes 19 are supported so that they are able to move in rotating fashion around this axis. For example, the vanes 19 can be manufactured having a shell construction. To this end, the vanes 19 have a vane axis section and an outer skin for absorbing normal forces, flexural forces, and torsional forces as well as torques (see FIG. 5).

[0105] FIG. 5 shows a detail V indicated in FIG. 4 of the blade 7 with the pitch drive 12 in a schematic cross-sectional view along the blade rotation axis C_7 . The pitch drive 12 has a pitch motor 27, which is positioned in a clearance 28 between the upper middle section 13b and lower middle section 13c of the blade 7. The pitch motor 27 is embodied as an electronically controlled, transmissionless, air-cooled torque motor and has a stator ring 29 and a rotor ring 30 that is circumferentially surrounded by the stator ring 29 and is spaced apart from it by a gap. A cooling body 31 with cooling fins 32 is fastened to an outer circumference surface of the stator ring 29 so as to be able to dissipate waste heat of the pitch motor 27.

[0106] The rotor ring 30 of the pitch motor 27 is mounted on a rim 33, which is embodied as a kind of collar that is of one piece with the motor shaft 25, at which rim the rotor ring 30 is connected in a rotationally coupled fashion to the essentially cylindrical motor shaft 25 with the aid of fastening elements 34 in the form of bolts. The rotor ring 30 extends essentially on the outer circumference side along the motor shaft 25 and is positioned so that it is spaced radially apart from the motor shaft 25 by at most a small gap. By means of the rim 34, a drive torque of the pitch motor 27—which is electromagnetically generated between the stator ring 29 and the rotor ring 30 and acts in a direction oriented around the blade rotation axis C_7 —is transferred from the rotor ring 30 to the motor shaft 25.

[0107] A motor housing 35 of the pitch motor 27 forms a motor interior 36 in which the rotor ring is accommodated. The motor housing 35 has a top 37 and a bottom 38, which extend in a disk shape along and essentially parallel to the rim 33. On their inner circumference sides, the top 37 and bottom 38 are each respectively connected to a bearing seat 39. The top 37 and bottom 38 are connected to the stator ring 29 and cooling body 31 by means of walls of the motor housing 35 and, on a side of the pitch motor 27 facing the rotor arm 10 that supports the blade 7, are connected to a motor flange 40 of the pitch drive 12.

[0108] The motor flange 40 provides end surfaces 41 at which the rotor arm 10 is connected to the motor flange 40

by means of a mounting collar **42** connected to the rotor arm **10**. The mounting collar **42** provides a counterpart end surface **43** that faces radially away from the rotor rotation axis C_2 in the direction toward the circular path K of the blades **7**. The motor flange **40** and mounting collar **42** are connected to each other by means of connecting elements **44**, which are embodied for example in the form of detachable connecting elements **44** such as bolted connections. Between the end surfaces **41** of the motor flange **40**, there is an open space **40a** in order to provide sufficient space in the region of the cooling fins **32** for heat dissipation or more precisely stated, to prevent a heat buildup.

[0109] Reinforcing ribs **45** extend between the bearing seat **39** and motor flange **40** in order to be able to transmit the static and dynamic loads, which originate from the blade **7**, from the bearing seat **39** via the motor housing **35** to the motor flange **40** with as little distortion of the motor housing **35** as possible. The reinforcing ribs **45** are each advantageously embodied of one piece with the motor housing **35**, for example during the casting, and/or are connected by means of welding to the top **37**, bottom **38**, bearing seat **39**, and motor flange **40** or to the top **37**, bottom **38**, and bearing seat **39**; they extend away from the top **37** and bottom **38** in strut-like fashion. In addition to their reinforcing action, the reinforcing ribs **45** also contribute to the cooling of the pitch motor **37** through heat dissipation via the motor housing **35**.

[0110] At least one sensor element **46**, for example in the form of an induction sensor, is provided in the wall of the motor housing in order to detect a rotation position of the motor shaft **25** and thus of the blade **7** for the control or regulation of the vertical wind turbine **1**. Respective motor bearings **47** are positioned between the two bearing seats **39** and the motor shaft **25**. For example, the motor bearings **47** are embodied in the form of spherical roller bearings. They transmit high radial forces from the blades **7** to the rotor arms **10** and also stiffen the rotor **2** as a whole. In order to protect the motor bearings **47** from harmful environmental influences, the motor bearings **47** are each accommodated in a bearing receiving chamber **48**, which, to the greatest extent possible, is hermetically sealed by means of sealing elements **49**.

[0111] The sealing elements **49** seal the bearing receiving chamber **48**, both in relation to the motor interior **36** and in relation to the surroundings of the vertical wind turbine **1**. Toward the motor interior **36**, the bearing receiving chamber **48** is sealed by means of inner rings **50**, which—resting against the motor bearing **47** and, on the outer circumference side, against the sealing element **49** in the axial direction of the blade **7**, both in and away from the upward direction Z , respectively— isolate the bearing receiving chamber **48** from the motor interior **36**. The bearing receiving chamber **48** is sealed in relation to the surroundings of the vertical wind turbine **1** by means of outer rings **51**, which respectively rest against the outside of the bearing seat **39** and enclose the sealing element **49** on the inner circumference.

[0112] At its ends oriented toward the vanes **19**, the motor shaft **25** is connected to a transition section **52** or transitions into it in integral fashion. The transition section **52** widens as it extends away from the pitch drive **12** and is mounted in a vane axis section **53**, which rotationally couples the transition section **52** to the blade **7** in adapter fashion. To that end, connecting ends **55** of the transition section **52** extending in the direction along the blade rotation axis C_7 are embodied in flange-like fashion and are additionally pro-

vided with a compensation weight holder **56** for holding a compensation weight **56a** for the vane **19** so that they have flange sections **57** oriented axially away from the connecting ends **55**, on which positive-fit elements **58** and other connecting elements **59** are provided, for example likewise detachable ones in the form of bolt connections, which create a positive-fit and/or force-fit engagement between the transition section or more precisely, its flange section **57**, and the respective vane axis section **53**. The motor shaft **25**, the transition section **52**, and the vane axis section **53** extend coaxial to one another. The vane axis section **53** supports an outer skin **60** of the blade **7**.

[0113] FIG. 6 shows a schematic perspective view of the pitch drives **12** in which the pitch motor **27** is provided with an aerodynamic cover in the form of a casing **61**. The casing **61** has an upper shell **62** and a lower shell **63**, which enclose the motor housing **35** of the pitch motor **27** like a cowling and thus cover the top **37** and bottom **38** together with the reinforcing ribs **45** and support ribs **46** as well as the motor flange **40**, thus minimizing the size of a drive gap **64** that is formed between the pitch drive **12** and the blade **7** and minimizing the accompanying losses in pressure and output that occur at such a gap. Between the upper shell **62** and lower shell **63**, an annular gap-shaped cooling opening **65** is formed, which axially surrounds the cooling body **31** and through which the cooling fins **32** freely extend so that with ambient air circulating unhindered around them, they can give off the waste heat of the pitch motor **27** to the surroundings of the vertical wind turbine **1**.

[0114] The drive gap **64** is further reduced in that the casing **61** provides an extension **66**, which is formed in accordance with aerodynamic aspects, which adjoins the upper shell **62** and lower shell **63**, and outer contour of which in a projection along the blade rotation axis C_7 essentially corresponds to a blade profile of the blades **7**. In the direction toward the rotor arm **10**, the casing **61** is provided with end caps **67**, which rest flush against the motor flange **40** and an outer diameter of which, at least in some places, is adapted to an outer diameter of the mounting collar **42**. An outer contour of the mounting collar **42** is in turn adapted to an outer contour of the rotor arm **10**. As a result, the end caps **67**, the motor flange **40**, the connecting flange **42**, and the rotor arm **10** transition into one another with outer contours that are as flush with one another as possible and there is an aerodynamically advantageous transition between the pitch drive **12** and the blade mount **8**.

[0115] Further, it is illustrated in FIG. 6 that at least one intake socket **68a** or intake opening and a discharge opening **68b** are formed into the casing **61** of the pitch drive **12**. Between the intake socket **68a** and the discharge opening **68b**, a cooling air duct **69** is shaped into the casing **61** or is formed between the casing **61** and the pitch drive **12**. The intake opening embodied in the intake socket **68a** is oriented in the circumference direction along the circular path K so that during the rotation of the rotor **2**, the intake socket **68a** takes in ambient air and this is conveyed through the cooling air duct **69** along the cooling body **31** or more specifically its cooling fins **32** to the discharge opening **68b**. This prevents cooling air in the region of the cooling body **31** or more precisely its cooling fins **32** from flowing away from them, which helps to ensure a cooling of the pitch drive **12** that satisfies the respective requirements. In addition, two intake sockets **68a** and a discharge opening **68b** are advantageously provided, with a combined cross-section of the intake sock-

ets **68a** being greater than a cross-section of the discharge opening **68b**, as a result of which along the two cooling air ducts **69** per pitch drive **12** that are respectively formed between the intake sockets **68a** and the discharge opening **68b**, the cooling air tends to experience a slight compression and thus acceleration, which helps to further increase a cooling capacity of the cooling air.

[0116] FIG. 7 shows a schematic perspective view of a pitch motor **27** together with the blades **7** mounted thereon, particularly showing the motor flange **40** of the pitch motor **27** for fastening the pitch motor **27** together with the blade **7** to one of the rotor arms **10** of the rotor **2** of the vertical wind turbine **1**. Here, it becomes clear that the open space **40a** at the motor flange **40** is formed between upper housing half **35a** and a lower housing half **35b** of the motor housing **35**. As a result, the motor flange **40** has an upper flange half **41a** and a lower flange half **41b**, between which the pitch motor **27** is accessible from the respective rotor arm **10** and between which cooling air can flow along the cooling body **31**. The reinforcing ribs **45** on the motor housing **35** each provide a stabilization of the upper housing half **35a** and the lower housing half **35b** considered individually, in order to ensure that they are sufficiently rigid.

[0117] FIG. 8 shows a schematic partial cross-sectional view of the pitch motor **27**. In order to be able to lock the pitch motor **27** in position and thus prevent the blade **7** from being able to execute rotations around its blade rotation axis C_7 , the pitch drive **12** is provided with a motor-braking and/or motor-locking unit **27a**, which is arranged on the motor housing **35**, is accessible via the motor flange **40**, and is manually actuatable. For example, the motor-braking and/or motor-locking unit **27a** is embodied to cooperate in a form-locking manner with the compensation weight holder **56**, for example in that a locking bolt **27b** of the motor-braking and/or motor-locking unit **27a** engages in a positive-fit with a corresponding locking opening **27c** of the compensation weight holder, so that a locking of the motor shaft **25** relative to the motor housing **35** in at least one rotation direction around the blade rotation axis C_7 for maintenance and/or safety purposes prevents the pitch motor **27** and thus the blade **7** from executing any rotation around the blade rotation axis C_7 .

[0118] In addition, a first rotary position transducer **46a** and a second rotary position transducer **46b** extend parallel to each other along the outer circumference of the motor shaft **25** and are embodied to be detected by the at least one sensor element **46**. The first rotary position transducer **46a** is embodied for example as an absolute position transducer. The second rotary position transducer **46b** is embodied for example as a relative position transducer. The first rotary position transducer **46a** embodied as an absolute position transducer can for example have increments at least some of which are positioned at irregular distances from one another along the outer circumference of the motor shaft **25**. The second rotary position transducer **46b** embodied as a relative position transducer can for example have increments positioned at regular distances from one another along the outer circumference of the motor shaft **25**. As a result, the first rotary position transducer **46a** permits the determination of an absolute position of the motor shaft **25** and thus of the blade **7** around the blade rotation axis C_7 . The second rotary position transducer **46b** permits the determination of a relative position of the motor shaft **25** and thus of the blade **7** around the blade rotation axis C_7 . Using the first rotary

position transducer **46a** and second rotary position transducer **46b** in this way makes it possible to determine the rotation position of the motor shaft **25** and of the blade **7** with a high position resolution.

[0119] FIG. 9 shows a schematic cross-sectional view of a drive train **70** of the vertical wind turbine **1** along a drive shaft **71** of the drive train **70**, whose drive rotation axis C_{71} extends coaxial to the rotor rotation axis C_2 . The rotor hub **9** has a pedestal **72** that forms a stud **73**, which likewise extends coaxial to the drive rotation axis C_{71} and rotor rotation axis C_2 . At the place where the pedestal **72** tapers toward the stud **73**, a hub shoulder **74**, which points away from the upward direction Z , is formed on the pedestal **72** and rests on a transition ring **75**, which in turn rests axially in a direction oriented away from the upward direction Z on a first rotor bearing **76a**, which constitutes a part of a rotor bearing system **76**.

[0120] In addition to the first rotor bearing **76a**, the rotor bearing system **76** also includes a second rotor bearing **76b** and a third rotor bearing **76c**. The first and second rotor bearings **76a**, **76b** are embodied for example as prestressed conical roller bearings and transmit radial loads resulting from wind loads to the tower system **4**. For this purpose, the first and second rotor bearings **76a**, **76b** are mounted on a rotor shaft **78** by means of a separate bearing bush **77**. The part of the rotor bearing system **76** comprising the first and second rotor bearings **76a**, **76b** is assembled in an axially free-floating fashion in a hub connection **79** that constitutes a machine support and therefore remains free of vertical loads. The third rotor bearing **76c** absorbs the vertical loads of the rotor **2** and thus essentially its weight force and for this purpose, is advantageously embodied in the form of an axial spherical roller bearing, which introduces the vertical loads directly into the nacelle **3**.

[0121] Below the nacelle **3**, a transmission **80** of the vertical wind turbine **1** is arranged in which a rotor speed of the rotor shaft **78** is converted into a generator rotation speed at an output shaft **82** of the transmission **80**. A clutch unit **83**, for example in the form of a double-Catalan, torsionally rigid steel disk clutch, connects the output shaft **82** in a torque-transmitting fashion to a generator shaft **84** of a generator **85**, for example a synchronous machine with permanent magnets, in order to produce electrical current, in this case for example with a maximum power of 750 kW. The clutch unit **83** prevents a redundant dimensioning of bearing forces. To limit the torque, the rotor shaft **78** is provided with an intended break point **86** (for example with a nominal torque of 500 kNm; an intended break moment of 1000 kNm; and a permissible transmission peak torque of 1500 kNm).

[0122] The transmission **80** converts the low rotor speed according to the invention into a high generator rotation speed. For example, a transmission step-up factor i amounts to roughly 65 to 75, preferably approx. 70. A transmission housing **87** of the transmission **80** is rigidly screw-mounted to the hub connection by means of a flange bell **88**. This results in a direct feedback of the high operating torque. Between the rotor shaft **78** and drive train **70**, there is a double-cardan, spherically ground double-tooth clutch **89**, which transmits the torque of the rotor **2** to the transmission **80** without redundant dimensioning of bearing forces.

[0123] In addition, a pitch pipe **90** passes through the transmission **80** coaxial to the rotor shaft **78** and serves as a feed-through for control wires and power cables for the pitch

drive 12. The pitch pipe 12 is driven to a point above the intended break point 86 in the coupling 89 by being rotationally coupled to the rotor 2. Thus, after a breakage occurs at the intended break point 86 and after the system subsequently coasts to a stop, the cables and lines for transmitting signals and/or power (see FIG. 16) are not twisted and therefore remain intact. At the lower end of the pitch pipe 90, a slip ring packet 90a is provided, in which the mutual cooperation of corresponding brushes and slip rings (not shown) connects the signal wires, control wires, and power cables for the pitch drive 12 in an electrically conductive fashion to corresponding control wires and power cables inside the tower 4, which then lead to the switchgear box 6.

[0124] FIG. 9 also shows that the transmission 80 has a plurality of transmission stages, in the present case for example a first transmission stage 80a, a second transmission stage 80b, and a third transmission stage 80c. The first transmission stage 80a and second transmission stage 80b are each embodied as a planetary gear stage 81. The planetary gear stages 81 have respective planet gears 81a, which are each supported on a strut 81c by means of a flexible pin 81b. With their respective gears, the planet gears 81a engage simultaneously with a ring gear 81d and a sun gear 81e of the respective planetary gear stage 81. The sun gear 81e of the second transmission stage 80b is connected in a torque-transmitting way by means of a slip clutch 89a to a gear 81f of the third transmission stage 80c, which is embodied as a spur gear pair. The gear 81f engages with a pinion 81g of the third transmission stage 80c. The pinion 81g is connected in a torque-transmitting way to the drive shaft 82 for the generator 85.

[0125] FIG. 1 shows a schematic perspective view of an embodiment according to the invention of the hub connection 79 of the vertical wind turbine 1. The hub connection 79 includes a cylindrical, drum-like integrally formed base body 91, which provides a feed-through 92 for accommodating a shaft bearing unit 93 (see FIG. 9) of the drive train 70. Supporting feet 94 are fastened equidistantly to the outer circumference side of the base body 91 and extend out radially from it. The supporting feet 94 each provide a horizontally oriented rest 95 for mounting the hub connection 80 onto the tower system 4. The supporting feet 94 can for example be composed of welded-together plates and be integrally connected to the base body 91 by welding or be flange-mounted to it; the base body can in turn also be composed of welded-together plates.

[0126] The hub connection 79 can be composed of a plurality of identically shaped segments, which each provide two flange ends, at which they are connected to one another enclosing a circle and thus combine to form the feed-through 92 for accommodating the shaft bearing unit 93. Each of the segments 96 constitutes a supporting arm. At the distal end of each supporting arm oriented away from the feed-through 92, a vertically extending supporting tab can be formed, which lies in a respective radial plane relative thereto for being mounted onto the tower system 4. For example, the segments can be cast individually or in one piece, which can help to reduce manufacturing costs, particularly in mass production and can help to adapt material thicknesses of the segments in high-stress points and can also help to provide rounded regions on it in order to reduce stress concentrations, for example by having the flange ends transition into the supporting arms by forming a curved profile.

[0127] The rotor hub 9 itself can likewise be composed of segments 95 or be integrally cast together with its segments 95. On each of the segments 95, there is a flange end 97 for fastening one of the rotor arms 10 to the rotor hub 9. Each flange end 97 can be formed onto a supporting arm 98, which is provided on the rotor hub 9 and extends away from the rotor rotation axis C_2 . The supporting arms 98 can be formed of one piece with the respective segment 95.

[0128] The rotor arms 10 have an upper arm half 10a and a lower arm half 10b, which in the radial direction of the rotor 2 oriented toward the rotor hub 9, are brought together at a hub end 10c of the rotor arm 10. At the hub end 10c, a rotor arm hub flange 10d is provided for fastening the rotor arm 10 to one of the flange ends 97 of the rotor hub 9. Between the upper arm half 10a and lower arm half 10a extending along a longitudinal axis span of the rotor arm 10, a connecting segment 10e of the rotor arm 10 is provided, which connects the upper arm half 10a and lower arm half 10b to each other along their longitudinal span.

[0129] The signaling and/or measuring unit 11 can be positioned on a covering cap 99 for the rotor hub 9 and for example includes a plurality of wind speed sensors 104 and wind direction sensors 105, which are each fastened to a rod 106 that extends away from the covering cap 99. Viewed in the axial direction of the vertical wind turbine 1, the rods 106 can each be positioned offset from the rotor arms 10 so that as much as possible, the respective wind speed sensors 104 and wind direction sensors 105 do not lie in the wind shadow of the blades 7 as the rotor 2 rotates around its rotor rotation axis C_2 or in any case, only lie in their wind shadow for the shortest possible time intervals.

[0130] FIG. 11 shows a schematic front view of a section of one of the rotor arms 10 of the rotor 2 of the vertical wind turbine 1. Here, it becomes clear that a rotor arm blade flange 10g and the mounting collar 42 for fastening the rotor arm to the blade 7 and to the respective motor flange 40 are provided at a distal rotor arm end 10f. The depicted section of the rotor arm 10 can be either the upper arm half 10a or the lower arm half 10b, which are shaped identically in order to facilitate the production of the rotor arms 10 and to minimize their production costs.

[0131] FIG. 12 shows a schematic side view of the section shown in FIG. 11 of one of the rotor arms 10 of the vertical wind turbine 1. Here, it becomes clear that the rotor arms 10 taper in the vertical direction Z from the hub end 10c toward the rotor arm end 10f.

[0132] FIG. 13 shows a schematic cross-sectional view of the section shown in FIGS. 11 and 12 of one of the rotor arms 10 of the vertical wind turbine 1, along the cross-sectional line A-A shown in FIG. 12. Here, it becomes clear that in the region of the hub end 10, the rotor arms 10 have a wall thickness that is sufficient for embodying the vane axis section 53 in such a way that the respective vane 19 can be fastened to the flange section 57.

[0133] FIG. 14 shows a schematic top view of the section shown in FIGS. 11 to 13 of the rotor arm 10 of the vertical wind turbine 1. Here, it becomes clear that the rotor arms 10 likewise taper transversely to the vertical direction Z vertical direction Z from the hub end 10c toward the rotor arm end 10f.

[0134] FIG. 15 shows a schematic top view of the vertical wind turbine 1 to illustrate angular positions and force conditions at the blades 7 during the operation of the vertical wind turbine 1. During the operation of the vertical wind

turbine **1**, the wind flows against the blades **7** at a wind speed v_W . The rotation of the rotor **2** around the rotor rotation axis C_2 produces an angular velocity ω of the rotor **2**, which, multiplied by a radius R_K of the circular path **K** that corresponds to half of the diameter D_K of the circular path **K**, yields a circumferential speed v_U of the blades **7** along the circular path **K** according to equation (1) below:

$$v_U = \omega \times R_K \quad (1)$$

[0135] A difference between the wind speed v_W and the circumferential speed v_U yields a relative speed v_R of the blade **7** moving along the circular path **K** in relation to the wind according to equation (2) below:

$$v_R = v_W - v_U \quad (2)$$

[0136] Between the vectors of the circumferential speed v_U and the relative speed v_R at the blade **7**, there is an angle of incidence γ , which is calculated according to equation (3) below from a sum of a relative angle of incidence or angle of attack α and a gradient angle or pitch angle β :

$$\gamma = \alpha + \beta \quad (3)$$

[0137] The angle of attack α is respectively measured between the vector of the circumferential speed v_U and a chord line **100** of the blades **7**, which extends in a straight line between a leading edge **101** and a trailing edge **102**. The pitch angle β is measured between the vector of the relative speed v_R and the chord line **100**. The blades **7** have a symmetrical blade profile, by means of which the blade chord forms a plane of symmetry of the blades **7** or their vanes.

[0138] Through the rotation of the rotor **2** around the rotor rotation axis C_2 , the relative speed v_R is a function of an azimuth angle Θ of the rotor **2**, which is measured for example for the respective rotor arm **10** starting from a zero point at a position 90° from the wind direction, facing into the wind and rotating relative to a main axis of the vertical wind turbine **1**. A tangent of the angle of incidence γ is calculated as a function of the wind speed v_W , the relative speed v_R , and the azimuth angle Θ or as a function of a tip speed ratio λ and the azimuth angle Θ according to equation (4) below:

$$\tan \gamma = \frac{v_W \sin \theta}{v_R + v_W \cos \theta} = \frac{\sin \theta}{\lambda \cos \theta}, \quad (4)$$

where the tip speed ratio λ in turn, according to equation (5) below, corresponds to a ratio of the circumferential speed v_U to the wind speed v_W and according to the invention, is to be set as optimally as possible and kept constant by means of the respective pitch drive **12** or more precisely, its pitch motor **27**, in accordance with the respective wind conditions with varying pitch angles β in order to maximize an energy yield or performance of a vertical wind turbine **1** according to the invention:

$$\lambda = \frac{v_U}{v_W} \quad (5)$$

[0139] In order to minimize an adjusting torque of the pitch drive **12**—which is required to vary the pitch angle β by rotating the blade **7** around the rotor rotation axis C_7 —,

it is advantageous if a static center of gravity of the blade **7** lies on or as close as possible to the rotor rotation axis C_7 . For example, the rotor rotation axis C_7 is positioned on the chord line **100** at 20 to 23%, preferably 21.5%, of a rotor blade depth measured from the leading edge **101**. In order to position the center of gravity on the rotor rotation axis C_7 , the counterweight **56a** is provided in the region of the pitch drive **12** and if need be, an additional counterweight **103** is positioned in the region of the leading edge **101** in the blade **7**. For example, the additional counterweight **103** is composed of rod segments, preferably of a round steel rod with diameters of between 60 and 100 mm, most preferably 80 mm. The rod segments are fastened to the ribs **54**. The segments can be advantageously connected to one another in an electrically conductive fashion. As a result, the additional counterweight **103** can perform a double function in that it also serves as a lightning rod.

[0140] In addition, the vertical wind turbine **1** has at least one wind speed sensor **104** and/or wind direction sensor **105**. The wind speed sensor **104** and/or wind direction sensor **105** is positioned at the upper end of the signaling and/or measuring mast **11** and/or on at least one of the blades **7** or on all of the blades **7**. The wind speed sensor **104** and/or wind direction sensor **105** is preferably fastened to the blade **7** in the region of the pitch drive **12** because wind speeds and/or directions measured there are highly relevant for the control of the pitch drive **12**.

[0141] In order to keep the wind speed sensor **104** and/or wind direction sensor **105** outside of air turbulence caused by the blade **7**, the wind speed sensor **104** and/or wind direction sensor **105** is positioned at the distal end of a rod **106**, which is fastened to the blade **7** or pitch drive **12** and, oriented radially away from the rotor rotation axis C_2 , protrudes beyond the circular path **K** into a region in the vicinity of the vertical wind turbine **1**, which lies as far as possible outside of air flow boundary layers that are formed around the rotor **2** and its components, i.e. largely outside of the influence range of the blade **7**.

[0142] FIG. 16 shows a schematic diagram to illustrate the function of a control device according to the invention **107** of the vertical wind turbine **1**. The control device **107** includes a supply unit **108**, which is on the one hand connected to a motor control unit **109** that includes a power section **110** and on the other hand, is connected to a choke **111** and a filter **112** in order to ensure the most malfunction-free and error-free power supply possible. For example, the power unit **110** is embodied as an inverter.

[0143] Via lines **113** for transmitting signals and/or power, the motor control unit **109** is connected to the pitch drive **12**, a power supply unit **114**, and a control unit **115** for monitoring and controlling the vertical wind turbine **1**. The power supply unit **114** includes a main power supply unit **116** and an auxiliary power supply unit **117**, the latter ensuring an emergency power supply to the control device **107** if the main power supply unit **116** fails or is not available.

[0144] In addition, the control device **107** includes a motor protection unit **118** and a data transmission unit **119**. The pitch drive **12** also includes a rotary position transducer **120** with a position sensor **121** for monitoring a rotation position of the rotor ring **30** relative to the stator ring **29**. The pitch motor **27** also includes a motor unit **122**, which includes at least the stator ring **29** and the rotor ring **30**, and a temperature measuring unit **123**, which has a first temperature sensor **124** and at least one other temperature sensor **125**. For

example, the first temperature sensor **124** is embodied as a resistance-dependent temperature sensor (KTY), whereas the other temperature sensor **125** is embodied for example as a temperature sensor with a positive temperature coefficient (PTC).

[0145] During operation of the vertical wind turbine **1**, the power section **110** of the motor control unit **109** of the control device **107** inverts—for example continuously—a current that is required to drive the pitch motor **27**. For example, the power element **110** can output a continuous current of 100 to 200, preferably 150 A_{RMS} , and produce a peak current of 200 to 250, preferably 210 A_{RMS} , so that it is possible to quickly obtain a maximum torque of the pitch motor **27**. The control unit **115** cyclically calculates a set-point value S for the adjustment of each of the blades **7**, for example in the form of a set-point pitch angle β_S , and supplies it via the corresponding line **113** to the motor control unit **109**.

[0146] With the aid of the rotary position transducer **120**, an actual value I such as an actual pitch angle β_I is determined and is transmitted via the corresponding line **113** to the motor control unit **109**. Based on the set-point value S and the actual value I , the motor control unit **109** determines a differential value d , for example an angular deviation δ , and based on it, derives a control value U , for example in the form of a control current A , which is transmitted to the respective drive unit **12** and/or the motor unit **122** of the pitch motor **27**. Correspondingly, the motor control unit **109** adjusts the pitch angle β according to the invention with the least possible angular deviation δ .

[0147] With the aid of the temperature sensor **124** and the other temperature sensor **125**, the temperature measuring unit **123** detects a first temperature measurement value T and at least one other temperature measurement value T_x , which are determined for redundancy reasons and/or for different uses. Thus, the temperature measurement value T is transmitted via one of the lines **113** to the motor protection unit **118**. The motor protection unit **118** compares the temperature measurement value T to a temperature limit value and if the temperature limit value is exceeded, can transmit an alarm signal via the corresponding line **113** to the motor control unit **109**, where preventive measures for protecting the respective pitch drive **12** are initiated, for example an emergency shut-off or interruption of the power supply. At the same time, the motor protection unit **118** can use the corresponding line **113** to transmit temperature values for relaying temperature data to the motor control unit **109** and/or control unit **115** and the data transmission unit **119**.

[0148] The other temperature measurement value T_x is transmitted via corresponding lines **113** directly to the motor control unit **109** in order to keep a temperature of the drive unit **12** and the components thereof within the scope of a predetermined or specified operating temperature. In the motor control unit **109**, immediate temperature control measures can be initiated, whereas in the control unit **115**, longer-term temperature control measures can be carried out. Thus with the aid of the alarm signal sent by the motor protection unit **118** on the basis of the temperature measurement value T , a rapid temperature control can be carried out in order to protect the drive unit **12**, whereas the temperature data that are related to the control unit **115** can be used to perform a long-term temperature control and through the

direct relaying of the other temperature measurement value T_x to the motor control unit **109**, a middle-term temperature control is possible.

[0149] The control device **107** is configured and set up to implement the following ten operating modes **M0** to **M9** of the vertical wind turbine **1**:

[0150] **M0**: The vertical wind turbine **1** is switched off in a zeroth operating mode **M0**.

[0151] **M1**: Start-up readiness of the vertical wind turbine **1** from still air in a first operating mode **M1** at wind speeds below a starting wind speed v_1 , i.e. with $0 \leq v_W < v_1$, for example where $v_1 = 3$ m/s;

[0152] **M2**: Start-up of the vertical wind turbine **1** in a second operating mode **M2** at wind speeds above the starting wind speed v_1 and below a nominal wind speed v_2 , i.e. with $v_1 < v_W < v_2$, for example where $v_2 = 12$ m/s;

[0153] **M3**: Switching of the vertical wind turbine **1** from a resistance mode where $\lambda \leq 1$ starting into a fast mode where $\lambda > 1$ in a third operating mode **M3** or start-up mode at wind speeds above the starting wind speed v_1 and below a first cut-out wind speed v_3 , i.e. with $v_1 \leq v_W < v_3$, for example with a minimum rotation speed of the rotor of 4 [rpm] and a first cut-out wind speed $v_3 = 20$ m/s (average measured over 10 minutes);

[0154] **M4**: Shut-down of the vertical wind turbine **1** in a fourth operating mode **M4** at wind speeds above the first cut-out wind speed v_3 or a further cut-out wind speed v_4 , i.e. with $v_W > v_3$ or $v_W > v_4$, respectively, for example where $v_4 = 30$ m/s (average measured over 3 seconds);

[0155] **M5**: Restarting of the vertical wind turbine **1** in a fifth operating mode **M5** when the wind speed falls below a restart wind speed v_5 after a shut-down in the fourth operating mode **M4**, for example where $v_5 = 18$ m/s;

[0156] **M6**: Operation of the vertical wind turbine **1** at a constant tip speed ratio λ in a sixth operating mode **M6** or partial load mode for wind speeds above the starting wind speed v_1 and below a nominal wind speed v_2 , i.e. with $v_1 \leq v_W < v_2$, for example with a tip speed ratio λ between 2 and 2.6, preferably between 2.2 and 2.4, most preferably 2.3 at a nominal wind speed v_2 of 12 m/s and a circumferential speed of the blades **7** on the circular path K of $v_U = 27.6$ m/s;

[0157] **M7**: Operation of the vertical wind turbine **1** with a variable tip speed ratio λ in a seventh operating mode **M7** or nominal operation mode or also full-load operation with a nominal speed of the rotor of for example 16.5 [rpm] at wind speeds above the nominal wind speed v_2 and below the first cut-out wind speed v_3 or the further cut-out wind speed v_4 , i.e. in a nominal wind speed range with $v_2 \leq v_W < v_3$ or $v_2 \leq v_W < v_4$; for example with a tip speed ratio λ between 1 and 1.8, preferably between 1.3 and 1.5, most preferably 1.38 at a first cut-out wind speed v_3 of 20 m/s;

[0158] **M8**: Emergency shut-down of the vertical wind turbine **1** in an eighth operating mode **M8** at extreme wind speed increase gradients dv_W/dt greater than a shut-down gradient of the wind speed; and

[0159] **M9**: Switching-off of the vertical wind turbine **1** in a ninth operating mode **M9** to switch the vertical wind turbine **1** into the zeroth operating mode from one of the operating modes **M1** to **M8**.

[0160] FIG. 17 shows a schematic diagram of a sample torque characteristic curve of the pitch motor 27. The diagram shows a maximum torque T_p , a nominal torque T_i , and continuous torque T_c of the pitch motor 27 over the rotation speed of the pitch motor 27. The pitch motor 27 can rapidly produce the maximum torque T_p in order to spontaneously, i.e. within a very short, extremely limited time, perform a quick adjustment of the respective blade 7. When the maximum torque T_p is exceeded, i.e. when an overload occurs, the motor slips and is thus inherently safe, i.e. no damage to the motor occurs. The nominal torque T_i can be used continuously until a temperature limit value is exceeded. As a rule, the continuous torque T_c is available on an ongoing basis and does not lead to temperature limit values being exceeded.

[0161] FIG. 18 shows a schematic diagram with sample cam disks for controlling the pitch motor 12, namely a first cam disk S1, which is provided for example for the nominal wind speed v_2 of for example 12 m/s, and a further cam disk S2, which is provided for the first cut-out wind speed v_3 of for example 20 m/s. Between these two wind speeds, for example a nominal-load operation or full-load operation of the vertical wind turbine 1 in the seventh operating mode M7 is provided, in which the rotor 2 rotates at a nominal speed and the generator 85 outputs its nominal power. For each cam disk S1, S2, the set-point value S of the pitch angle β is represented as the set-point pitch angle β_S in dependence of the azimuth angle Θ .

[0162] At the nominal wind speed v_2 , the set-point pitch angle β_S at an azimuth angle Θ of 0° is less than 0° , for example in the range from -2 to -3° . On the way to an azimuth angle Θ of 90° , the set-point pitch angle β_S first passes through a local maximum of -2 to -3° at an azimuth angle Θ of approx. 20° and then passes through an inflection point between -3 and -4° at an azimuth angle Θ of approx. 20° until the set-point pitch angle β_S at an azimuth angle Θ of approx. 50° reaches an absolute minimum of approx. -10° .

[0163] At an azimuth angle Θ of 180° , the set-point pitch angle β_S for the nominal wind speed v_2 is once again approx. 2 to -3° and then, at an azimuth angle Θ of approx. 200° , reaches a value of 0° . At an azimuth angle Θ of approx. 250° , the set-point pitch angle β_S for the nominal wind speed v_2 reaches its absolute maximum of approx. 2 to 3° and then at an azimuth angle Θ of approx. 290° once again reaches a value of 0° and at approximately the same time, passes through an inflection point. Then the set-point pitch angle β_S passes through a local minimum of approx. -3 to -4° at an azimuth angle Θ of approx. 330° and finally, at an azimuth angle Θ of approx. 360° , returns once again to its initial range of -2 to -3° .

[0164] At the first cut-out wind speed v_3 , the set-point pitch angle β_S at an azimuth angle Θ of 0° is less than 0° , for example in the range from -1 to -2° , and is thus less than the set-point pitch angle β_S at an azimuth angle Θ of 0° at a nominal wind speed v_2 . On the way to an azimuth angle Θ of 90° , without a local maximum, the set-point pitch angle β_S passes through an inflection point between -14 and -16° at an azimuth angle Θ of approx. 45° until, at an azimuth angle Θ of approx. 100° , the set-point pitch angle β_S passes through another inflection point at approx. -30° and then, at an azimuth angle Θ of approx. 100° , reaches an absolute minimum of approx. -37° to -38° .

[0165] At an azimuth angle Θ of 180° , the set-point pitch angle β_S for the first cut-out wind speed v_3 , like the set-point pitch angle β_S for the nominal wind speed v_2 , is approx. -2 to -3° and then, at an azimuth angle Θ of approx. 170° , reaches a value of 0° earlier than the set-point pitch angle β_S for the nominal wind speed v_2 . At an azimuth angle Θ of approx. 230 to 240° , the set-point pitch angle β_S reaches its absolute maximum of approx. 35° and then, at an azimuth angle Θ of approx. 270° , reaches an inflection point at approx. 25° . Then the set-point pitch angle β_S passes through an inflection point at approx. 15° at an azimuth angle Θ of approx. 320° and finally, at an azimuth angle Θ of approx. 360° , returns once again to its initial range of -1 to -2° .

[0166] FIG. 19 shows a schematic perspective view of a test bench 200 for determining a positioning error of the pitch motor 27 of the vertical wind turbine 1. On the test bench 200, a frame structure 201 is provided, to which is attached a holding arm 202 for holding the pitch drive 12 or pitch motor 27 and a transverse arm 203. The pitch drive 12 together with a section of the blade 7 is mounted on the holding arm 202 of the test bench 200 by means of the motor flange 40 similarly to how it would be mounted to the rotor arm 10 of the vertical wind turbine 1. The transition section 52 protruding out from the pitch motor 27 is accommodated in a shaft mount 204 of the test bench 200 so that it is able to rotate around the blade rotation axis C_7 .

[0167] The shaft mount 204 is positioned in the middle of a swing arm 205, which is likewise held so that it is able to rotate around the blade rotation axis C_7 in an extension 206 of the frame structure 201. A weight 207 is secured at each of the two ends of the swing arm 205 oriented away from the blade rotation axis C_7 . The weights 207 simulate a total mass of the blade 7. In addition, the ends of the swing arm 205 are connected to the transverse arm 203 by means of spring elements 208 in the form of coil spring packs and articulating linkages 209 fastened thereto. The spring elements 208 simulate wind forces.

[0168] FIG. 20 shows a schematic diagram of a positioning error, which has been determined by means of the test bench 200 shown in FIG. 19, in the form an angular deviation δ of the pitch motor 27 in $^\circ$ over time t in seconds for a plurality of control cycles during which a simulated azimuth angle Θ passes through a respective rotor rotation of 360° . After an initial transient response, which does not occur in the vertical wind turbine 1, the angular deviation δ reaches an absolute value of less than 1.5° for set-point pitch angles β_S with absolute values of at most 30 to 40° .

[0169] FIG. 21 shows a schematic diagram of a positioning error of the pitch motor 27 in the form of the angular deviation δ in $^\circ$ over time t in seconds over one control cycle for the nominal wind speed v_2 . At a nominal wind speed v_2 , the angular deviation δ has an absolute value of always less than 0.5° and reaches a maximum absolute value of approx. 0.25° after respective local and absolute minima and maxima of the set-point pitch angle β_S . In the vicinity of the inflection points of the set-point pitch angle β_S , the angular deviation δ fluctuates around 0° .

[0170] FIG. 22 shows a schematic diagram of a positioning error of the pitch motor 27 in the form of the angular deviation δ in $^\circ$ over time t in seconds over one control cycle for the first cut-out wind speed v_3 . At the first cut-out wind speed v_3 , the angular deviation δ has an absolute value of always less than 1.5° and reaches a maximum absolute value of approx. 1.45° after respective local and absolute minima

of the set-point pitch angle β_s and reaches a maximum of approx. 0.6 at local and absolute maxima thereof. In the vicinity of the inflection points of the set-point pitch angle β_p , the angular deviation δ likewise fluctuates around 0°. In general, therefore, the angular deviation δ turns out to be slightly higher at the first cut-out wind speed v_3 than at the nominal wind speed v_2 .

[0171] Deviations from the above-described embodiments and implementation examples are possible within the scope of the concept of the invention. A person skilled in the art will therefore recognize that characteristic values and parameters of the vertical wind turbine 1 and its components as well as values for controlling the components are dependent on the dimensions of the vertical wind turbine 1 and are subject to change. Consequently, all of the above-mentioned absolute values of physical variables, e.g. wind speeds, are chiefly indicated for a design instance of the vertical wind turbine 1 described here, with a nominal power of 750 KW, a nominal height of 105 m, a rotor diameter of 32 m, a length of the blades 7 of 54 m, a height of the blades 7 over the ground of 51 m, a height of the middle of the blades 7 above the ground of 78 m, a survival wind speed of 59.5 m/s, and an annual average speed of 8.5 m/s and can be varied in accordance with other design instances, which can in turn result in deviations of relative physical variables such as tip speed ratios.

[0172] Also within the scope of the concept of the invention, unlike in the exemplary embodiment described here, more than two pitch drives 12 can be provided for each blade 7 or, for example, one pitch drive 12 can be provided for each blade section 13. In other words, two respective blades 7 or blade sections 13 can be provided, which are driven in a vertically separate way from each other. Thus for example, two pitch drives 12 can be positioned between two blades 7 or blade sections 13 and, as an upper and lower pitch drive 12, can be respectively associated with an upper and lower of the two blades 7 or blade sections 13. The upper blade or blade section 13 can thus be rotated around its blade rotation axis C_7 independently of the lower blade 7 or blade section 13.

[0173] Each of the two blades 7 or blade sections 13 can be associated with at least one wind speed sensor 104 and/or wind direction sensor 105. The at least one wind speed sensor 104 and/or wind direction sensor 105 is advantageously positioned in the middle of the respective blade 7 or blade section 13 and can be mounted on a rod 106 there as described above. Consequently, for each of the blades 7 or blade sections 13 positioned one above the other vertically, optimal pitch angles β can be separately set in order to take wind flow conditions that change in the vertical direction Z along the blade 7 into account during operation of the vertical wind turbine 1 and thus improve the efficiency of the turbine. This must be taken into consideration particularly for circular path diameters D_K that are larger than 32 m, for example 45 m, in which case a total length L_7 of the blades 7 would then be approx. 73 m, for example.

Reference Signs List	
1	vertical wind turbine
2	rotor
3	nacelle
4	tower system
5	footings

-continued

Reference Signs List	
6	switchgear box
7	blade
8	blade mount
9	rotor hub
10	rotor arm
10a	upper arm half
10b	lower arm half
10c	hub end
10d	rotor arm hub flange
10e	connecting segment
10f	rotor arm end
10g	rotor arm blade flange
11	signaling and/or measuring unit
12	pitch drive
13	blade section
13a	upper end section
13b	upper middle section
13c	lower middle section
13d	lower end section
13e	upper blade section
10f	lower blade section
14	bearing point
19	vane
25	motor shaft
26	blade axis
27	pitch motor
27a	motor-braking and/or motor-locking unit
27b	locking bolt
27c	locking opening
28	clearance
29	stator ring
30	rotor ring
31	cooling body
32	cooling fins
33	rim
34	fastening element
35	motor housing
35a	upper housing half
35b	lower housing half
36	motor interior
37	wall/top
38	wall/bottom
39	bearing seat
40	motor flange
40a	open space
41	end surface
41a	upper flange half
41b	lower flange half
42	mounting collar
43	counterpart end surface
44	connecting element
45	reinforcing rib
46	sensor element
46a	first rotary position transducer
46b	second rotary position transducer
47	motor bearing
48	bearing receiving chamber
49	sealing element
50	inner ring
51	outer ring
52	transition section
53	vane axis section
55	connecting end
56	compensation weight holder
56a	compensation weight
57	flange section
58	positive-fit element
59	further connecting element
60	outer skin
61	casing
62	upper shell
63	lower shell
64	drive gap

-continued

Reference Signs List	
65	cooling opening
66	extension
67	end cap
68a	intake socket/opening
68b	discharge opening
69	cooling air duct
70	drive train
71	drive shaft
72	pedestal
73	stud
74	hub shoulder
75	transition ring
76	rotor bearing system
76a	first rotor bearing
76b	second rotor bearing
76c	third rotor bearing
77	bearing bush
78	rotor shaft
79	hub connection
80	hub connection
80'	hub connection
80	transmission
80a	first transmission stage
80b	second transmission stage
80c	third transmission stage
81	planetary gear stage
81a	planet gear
81c	strut
81d	ring gear
81e	sun gear
81f	gear
81g	pinion
82	output shaft
83	clutch unit
84	generator shaft
85	generator
86	intended break point
87	transmission housing
88	flange bell
89	double-tooth clutch
90	pitch pipe
90a	slip ring packet
91	base body
92	feed-through
93	shaft bearing unit
94	supporting feet
95	rest
96	segment
97	flange end
98	supporting arm
99	covering cap
100	chord line
101	leading edge
102	trailing edge
103	additional counterweight
104	wind speed sensor
105	wind direction sensor
106	rod
107	control device
108	supply unit
109	motor control unit
110	power section
111	choke
112	filter
113	line
114	power supply unit
115	control unit
116	main power supply unit
117	auxiliary power supply unit
118	motor protection unit
119	data transmission unit
120	rotary position transducer
121	position sensor
122	motor unit

-continued

Reference Signs List	
123	temperature measuring unit
124	temperature sensor
125	other temperature sensor
200	test bench
201	frame structure
202	holding arm
203	transverse arm
204	shaft mount
205	swing arm
206	extension
207	weight
208	spring element
209	articulating linkage
i	transmission step-up factor
d	differential value
t	time
v_W	wind speed
v_U	circumferential speed
v_R	relative speed
v_1	starting wind speed
v_2	nominal wind speed
v_3	first cut-out wind speed
v_4	further cut-out wind speed
v_5	restart wind speed
A	control current
B ₄	maximum width of the tower system
C ₂	rotor rotation axis
C ₇	blade rotation axis
C ₇₁	drive rotation axis
D _K	diameter of the circular path
L ₇	length of the blades
K	circular path
I	actual value
P1	resistance force
P2	lifting force
S	set-point value
S1	first cam disk
S2	further cam disk.
T	temperature measurement value
T _x	other temperature meas. value
T _c	continuous torque
T _i	nominal torque
T _p	maximum torque
U	control value
R _K	radius of the circular path
X	longitudinal direction
Y	transverse direction
Z	vertical direction, upward direction
α	angle of attack
β	pitch angle
β_I	set-point pitch angle
β_S	actual pitch angle
δ	angular deviation
γ	angle of incidence
λ	tip speed ratio
Θ	azimuth angle
ω	angular velocity

1. A vertical wind turbine, comprising:

a plurality of vertical blades each fastened to and motor-driven pivotably around a respective vertical blade axis independently of other vertical blades, and the vertical blades are rotatably supported to travel along a common circular path (K) around a vertical rotor rotation axis (C2); and

a plurality of pitch motors, each pitch motor having a motor shaft,

wherein each vertical blade axis is operatively connected to the motor shaft of a respective pitch motor from the

- plurality of pitch motors for motor-driven pivoting of the vertical blade that is fastened to the vertical blade axis, and
- wherein the motor shaft of each pitch motor extends concentrically to a respective blade rotation axis.
2. The vertical wind turbine according to claim 1, further comprising a control device that controls the pitch motors; and at least one wind sensor connected to the control device, wherein the at least one wind sensor senses a wind characteristic.
3. The vertical wind turbine according to claim 2, wherein the wind characteristic is wind speed and/or wind direction.
4. The vertical wind turbine according to claim 2, wherein the at least one wind sensor is located at a pitch motor from the plurality of pitch motors.
5. The vertical wind turbine according to claim 2, wherein the at least one wind sensor is mounted on a rod that is fastened to the pitch motor, the rod extending beyond an outer edge of the vertical blade connected to the pitch motor.
6. The vertical wind turbine according to claim 5, wherein the at least one wind sensor is mounted on a distal end of the rod oriented away from the vertical blade.
7. The vertical wind turbine according to claim 2, further comprising a rotor hub, wherein the wind sensor is located on a mast positioned centrally on the rotor hub.

8. The vertical wind turbine according to claim 7, wherein the wind sensor extends vertically beyond an upper end of the vertical blades.

9. The vertical wind turbine according to claim 2, further comprising a motor hub, wherein the wind sensor is positioned at the motor hub.

10. The vertical wind turbine according to claim 1, further comprising a control device that controls the pitch motors; and a same number of wind sensors as the vertical blades connected to the control device, wherein each wind sensor senses a wind characteristic.

11. The vertical wind turbine according to claim 10, wherein the wind characteristic is wind speed and/or wind direction.

12. The vertical wind turbine according to claim 10, further comprising a rotor hub, wherein each wind sensor is fastened to an end of a rod that extends away from the rotor hub.

13. The vertical wind turbine according to claim 10, wherein each wind sensor is offset from the vertical blades in order to avoid wind shadowing by the vertical blades.

* * * * *