

J. CHANDLER.

SAFETY BLOCK AND SIGNAL SYSTEM FOR RAILWAYS.

No. 265,754.

Patented Oct. 10, 1882.

FIG. 1.

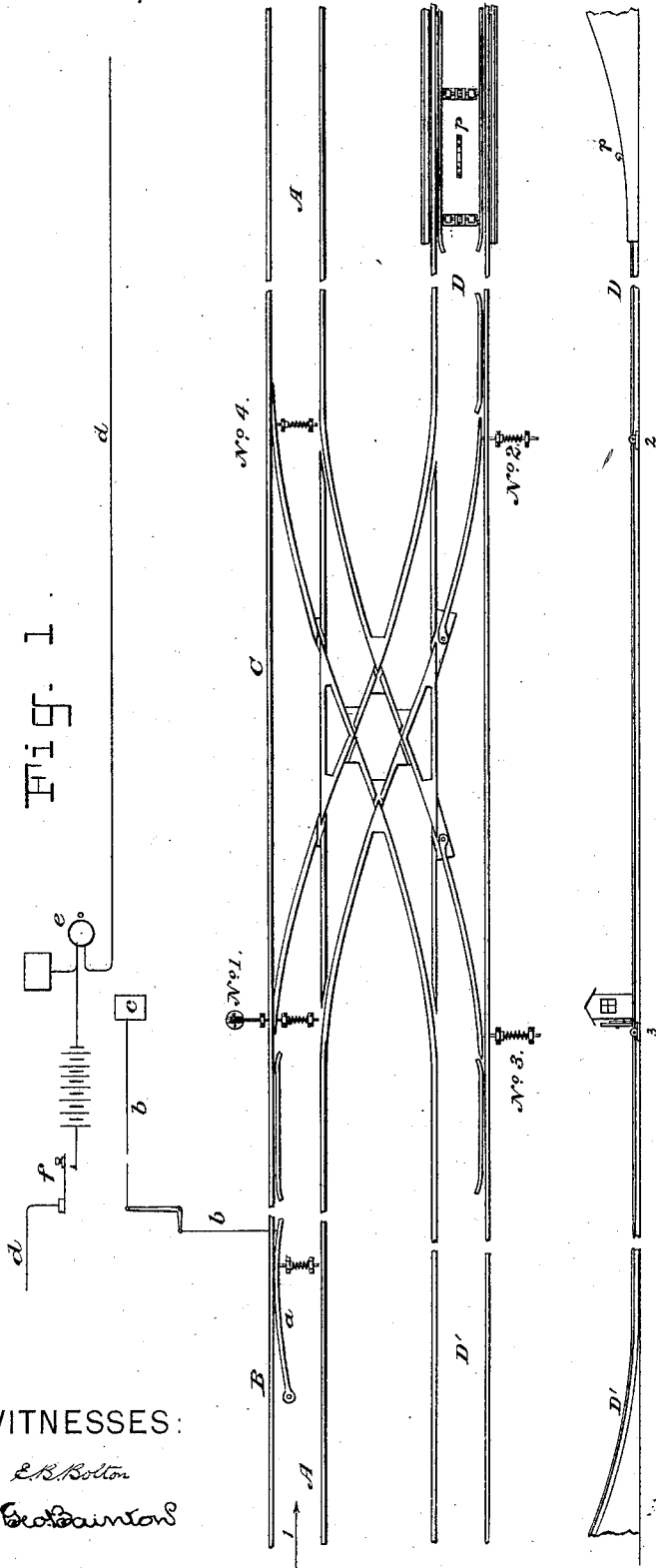

FIG. 2.

WITNESSES:

E. R. Bolton
Geo. Bainson

INVENTOR:

John Chandler
 By his Attorneys,
Burke, Ingersoll & Co.

J. CHANDLER.

SAFETY BLOCK AND SIGNAL SYSTEM FOR RAILWAYS.

No. 265,754.

Patented Oct. 10, 1882.

Fig. 3.

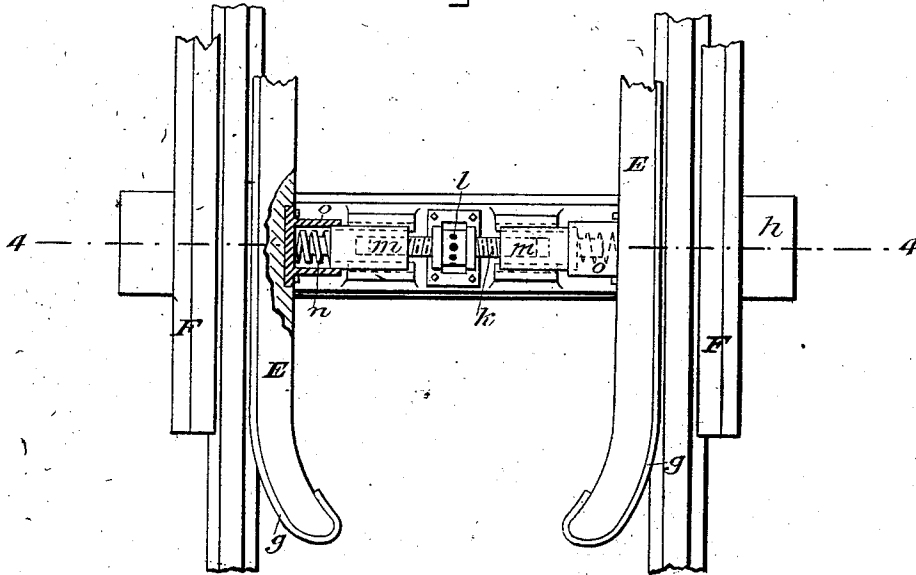

Fig. 4.

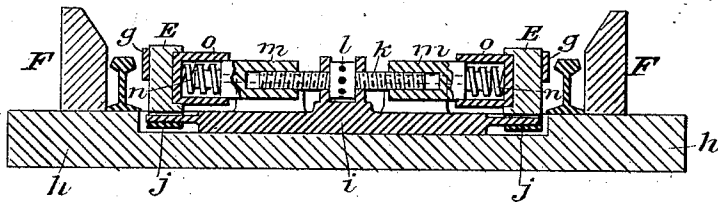
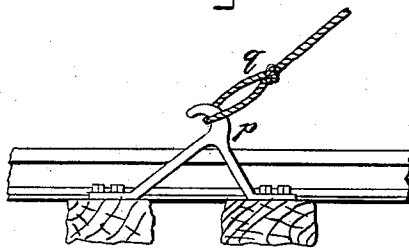

Fig. 5.



WITNESSES:

E. B. B. W.
Geo. Bainlow

INVENTOR:

John Chandler
 By his Attorneys,
Bank, Fraser & Bennett

J. CHANDLER.

SAFETY BLOCK AND SIGNAL SYSTEM FOR RAILWAYS.

No. 265,754.

Patented Oct. 10, 1882.

Fig. 6.

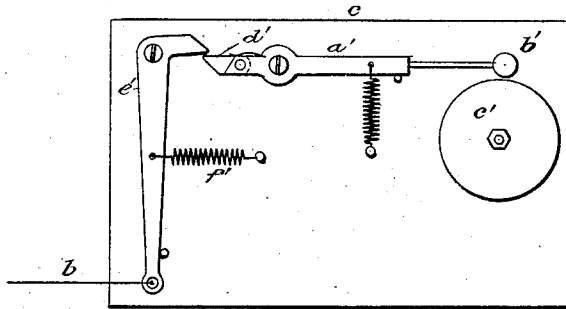
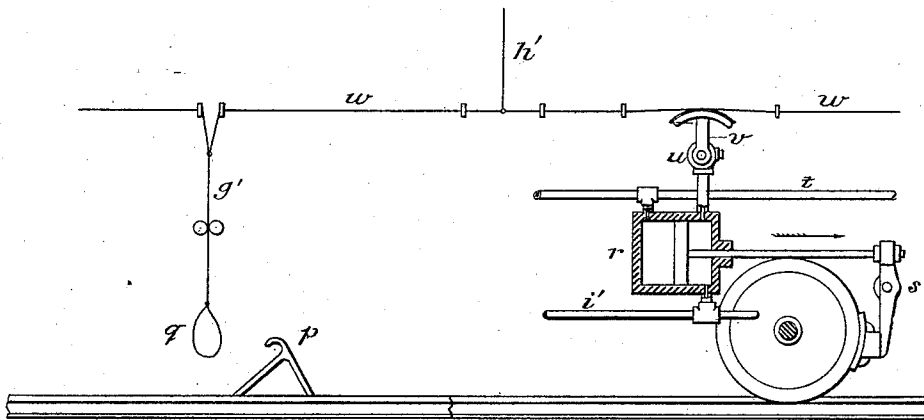

Fig. 7.



WITNESSES:

E. B. Bolton
Geo. Bainson

John Chandler

INVENTOR:

By his Attorneys,
Burke, Fraser & Co.

UNITED STATES PATENT OFFICE.

JOHN CHANDLER, OF BROOKLYN, NEW YORK.

SAFETY BLOCK AND SIGNAL SYSTEM FOR RAILWAYS.

SPECIFICATION forming part of Letters Patent No. 265,754, dated October 10, 1882.

Application filed April 1, 1882. (No model.)

To all whom it may concern:

Be it known that I, JOHN CHANDLER, a citizen of the United States, residing at Brooklyn, Kings county, New York, have invented certain Improvements in Safety Block and Signal Systems for Railways, of which the following is a specification.

This invention has for its object mainly the prevention of accidents on railways caused by collisions between trains running in one direction on the same track; and the leading principle or characteristic of my invention lies in the employment of a series of safety-sidings arranged at intervals and normally set to the main track, whereby the train will pass off the main track onto the siding should the switchman neglect his duty or in case the engineer of an approaching train fails to obey the injunction of the switchman to stop. In short, before an approaching train can enter a block it is necessary that the switchman at that point shall shift the switch and hold it open until the train has passed, when it closes automatically to the main line and opens to the safety-siding.

The invention also relates to certain specific features of construction which will be hereinafter fully described.

The novel features of the invention will be set forth in the claims.

In the drawings which serve to illustrate my invention, Figure 1 is a plan of the invention on a small scale, and Fig. 2 is a side elevation of the same. Figs. 3 and 4 are respectively a plan and cross-section detached and on a larger scale, illustrating the construction of my elastic clamping-rails. Fig. 5 is a view of the hook for setting the air-brake, shown in the act of catching the loop on the air-brake cord. Fig. 6 is an enlarged view of the gong-alarm to notify the switchman of the approach of a train. Fig. 7 is an illustrated fragmentary view, showing the arrangement of the air-brake and its valve and the connection of the cords for opening the valve and setting the brakes.

A represents the main line, arrow 1 showing the direction of the moving trains.

B represents one block, and C that next ahead. Switch No. 1 is in the main line at the junction of the blocks, and is normally closed

to the main line and open to the safety-siding D. This is a spring or self-closing switch, and may be thrown open by the switchman to permit a train on the main line to pass from block B into block C. The switchman at switch No. 1 is warned of the approach of a train by the following-described mechanism: At some distance from the switch, back on the track, is mounted a lever, *a*, which is pressed up to the inside of the rail by a spring. When the locomotive passes, the flange of its wheel, in passing between the rail and the lever *a*, presses the latter to one side. The free end of the lever is connected by a wire or cord, *b*, with an alarm-bell, gong, or other equivalent device, *c*, arranged near the switchman, and thus the movement of the lever is caused to sound an alarm or warn the switchman of the approach of the train.

In Fig. 6 I have shown a simple gong-alarm adapted for this purpose, which I will briefly describe. A lever or hammer-arm, *a'*, is provided with a hammer, *b'*, arranged to be thrown against a gong, *c'*, by a spring. The short end of this lever *a'* is provided with a spring-toe, *d'*, arranged to be engaged by the short arm of a bell-crank, *e'*, when the wire *b*, which is attached to the long arm of the bell-crank, is pulled by the movement of the lever *a*. The bell-crank is returned to its position by a spring, *f'*. This is a common device, and it or any of the well-known devices of the kind may be used—as a door-bell, for example.

In lieu of an audible signal, or in addition thereto, some kind of semaphore or visible signal may be employed.

In order that the switchman at switch No. 1 may know whether the preceding train has passed out of block C, there is arranged along the line an ordinary electric wire, *d*, having at each switch-station an electrical bell, *e*, and circuit-closing key *f*. When a train passes out of block C, for example, the switchman at the junction of blocks C and D closes the circuit and the bell *e* sounds. The switchman at switch No. 1 then knows that the track ahead is clear, and when he receives the signal of an approaching train by the sounding of bell *e* he throws open switch No. 1 and allows it to pass. He then closes the circuit at *f*, which rings a bell at the junction of blocks A and B

and notifies the switchman there that block B is clear. The ordinary electrical apparatus may be employed for this purpose, and it will be unnecessary to minutely describe it here.

5 I have described the ordinary routine when all is working right on the road; but should the switchman for some reason neglect his duty at switch No. 1 the consequence will be that the train will be switched off onto the 10 safety-siding D. This siding might be simply an ordinary level track of considerable length, long enough to enable the engineer to put on his brakes and check the train before it can run off the end. But it will some- 15 times happen that the brakes or throttle is defective and the locomotive cannot be controlled. In this case the switchman permits the train to run onto the safety-siding, and some means must be provided for checking its 20 momentum. For this purpose I provide two devices, which may be employed separately or jointly. One is to lay the tracks of the siding up a steep and gradually-increasing grade, as is described in my Patent No. 254,863, of March 25 14, 1882, and as shown in Fig. 2. When the train loses its momentum it will stop, and will then run back and up the grade on the auxiliary siding D'. The spring-switch No. 2 will yield to a train approaching from the main 30 track and allow the train to pass onto siding D; but in backing off this siding the said switch will throw the train onto siding D', and it cannot get off these sidings until switch No. 3 is shifted, which allows it to pass onto the 35 main track again at switch No. 4.

To check the momentum where it is inconvenient to employ a steep grade in the siding, or where it is inconvenient to employ an auxiliary siding, D', or where it is desirable to employ something in addition to the steep grade, 40 I employ the device shown in Fig. 1 on a small scale and in Figs. 3 and 4 on a larger scale. Referring to these figures, E E are clamping-rails arranged on the inside of the track and extending continuously, if desired, 45 the entire length of the siding D. I prefer to make these rails of wood, and to face them next the track-rail with iron strips *g g*. These rails are mounted to move to and from the 50 rails, and are kept pressed outward toward the rails by springs. When the train passes onto the siding supplied with these rails the flanges of the car and locomotive wheels wedge themselves between the rails E and the track- 55 rails, and the constant frictional pressure exerted will soon overcome the momentum of the train and bring it to a standstill.

Any suitable arrangement of springs to exert a yielding pressure on the rails E may be 60 employed. In Figs. 3 and 4 I have shown a convenient arrangement. On tie *h* is mounted a base-piece, *i*, to which the rails E are held down by sliding stirrups *j j* on the said rails. A screw, *k*, having right-and-left screw-threads 65 cut on its ends, and provided with capstan-head boss *l* at its middle, is mounted rotatively

in bearings on the base *i*. The ends of the screw *k* engage sliding nuts *m*, mounted in bearings in the base *i*, and springs *n* are arranged between said nuts and the rails E. To 70 better protect the springs from the weather I arrange them in metal housings *o*, bolted to the rails, and construct the nuts *m* to fit into these, as shown. Any kind of elastic material may be employed for the springs, and the springs 75 may be arranged at distances along the rails to suit the taste of the constructor or the exigencies of the case.

As the outward pressure of the rails E tends to force or spread the lower sides of the car- 80 wheels outward, and thus bring an injurious strain on the axle, I prefer, as a precaution, to fix guard-rails F along the outsides of the rails and close to the same, for the outer edges of the wheel-treads to bear against when the 85 pressure is too great. These receive the pressure and relieve the axles. These are the more necessary as the track-rails are apt to yield to the pressure of the wheel-flange. The vertical inner faces of these rails F rise about an 90 inch above the track-rail, and then the face is beveled off, as shown. Should the wheel jump the track, it will be caught on this beveled face.

When a train has been stopped by the rails E and it is desired to back it off the siding 95 onto the main track, the pressure of the springs may be relaxed by turning the screws *k*. This can be readily done by means of a short lever.

In lieu of the steep grade on the safety-siding, or in addition thereto, I may make this 100 track in the form of a circle or endless curve, where the ground will permit, and I may arrange my rails E E on the circular track precisely as described for a straight one, except that in this case they would be best made in 105 sections.

As an additional precaution, where the trains on the road employ air-brakes I mount in the safety-siding a rigid hook so set as to catch 110 into a loop on the air-brake cord. Then, if the engineer fails to set the brakes or is unable to do so from any cause, the engagement of the loop with the hook will instantly set the brakes. The loop may be constructed of some material 115 having strength enough to open the air-valve, but weak enough to break readily with any additional strain. This will free it properly from the hook.

In Fig. 1 I have shown the hook *p* set in the track D, and in Fig. 5 I have shown the con- 120 struction and arrangement of the same on a larger scale. In this figure, *p* is the hook, and *q* is the loop which hangs from the air-brake cord or valve. The loop *q* may be connected through the medium of a cord or wire with the 125 valves of any kind of air-brake in use by a very simple arrangement of the cords; but for a better understanding of this feature of my invention I have shown in Fig. 7 a means of operating the valve of an ordinary automatic West- 130 inghouse air-brake. I have not herein adhered to proportions nor shown all the details;

but with the following brief description any one familiar with such brakes will be enabled to properly arrange the cords:

Let *r* represent the air-cylinder of one car, its piston connected through the piston-rod with the brake-lever *s*. Movement of the piston forward in the direction of the arrow sets the brakes. A pipe, *t*, from the compressed-air reservoir on the locomotive supplies compressed air at the desired tension to all the cylinders in the train, behind the pistons of the same. The latter, however, are prevented from moving forward by a cushion of compressed air in front of them. The space in front of the piston has an outlet controlled by a cock or valve, *u*, and a lever-arm, *v*, on the plug of this valve is connected with a brake cord or wire, *w*, extending the entire length of the train. When the arm *v* stands vertical the cock is closed, but if moved either forward or backward the cock is opened, the compressed air escapes from in front of the piston, and the brakes are instantly set by the pressure behind the piston. The cord *w* runs through eyes and is connected with the air-valves on all the cars, whereby when the said cord is pulled all the brakes will be set. For convenience, a segment is fixed on the end of lever *v*, and the cord *w* is cut and laps at this point, the ends being attached to the ends of said segment in a well-known way. A cord, *g'*, connects the loop *q* with the cord *w*, and a cord, *h'*, connects cord *w* with the cord which extends through the cars, whereby the conductor is enabled to set the brakes. In releasing the brakes compressed air is admitted through pipe *v'* before the pistons, and the pipe *t* is simultaneously opened to the atmosphere. This is done by means of a three-way cock under control of the engineer. I also contemplate connecting the air-brake cord with the lever of a throttle-valve on the locomotive, whereby the engagement of the loop *q* with the hook *p* will also cut off the steam.

The switches are all self-closing, and this closing may be effected by springs of metal or rubber or by weights, as preferred.

Having thus described my invention, I claim—

1. In a safety block system for railways, the

combination, with the main track, of a series of safety-sidings connected with the main tracks by self-closing switches closed normally to the main track and open to the safety-siding, and the said switches, substantially as shown, whereby the services of switchmen are rendered necessary to keep the trains on the main track, for the purposes specified.

2. In a safety block and signal system for railways, the combination, with the main track, of a series of safety-sidings connected with the main track by self-closing switches closed normally to the main track and open to the sidings, the said switches and signal mechanisms to be actuated by the wheel-flange of the locomotive to warn the switchman of the approach of a train, all arranged substantially as and for the purposes set forth.

3. In a safety block and signal system for railways, the combination, with the main track, of the siding *D*, provided with the pressure or clamping rails *E E*, the self-closing switch No. 1, closed normally to the main track and open to the siding, the lever *a*, cord *b*, and signal *c*, all constructed and arranged to operate substantially as set forth.

4. As a means for checking the momentum of a train on a safety-siding, the clamping-rails *E E*, arranged at the inside of the track-rails and kept normally and elastically pressed toward the latter, as set forth, whereby the flanges on the wheels of the locomotive will be frictionally impeded, substantially as set forth.

5. The combination, with the clamping-rails *E E* and the track-rails of the sidings, of the guard-rails *F*, all constructed and arranged to operate substantially as set forth.

6. As a means of automatically setting the air-brakes on a train, the rigidly-fixed hook on the safety-siding, arranged to catch a loop suspended from the valve or valve-cord of the air-brake, substantially as set forth.

In witness whereof I have hereunto signed my name in the presence of two subscribing witnesses.

JOHN CHANDLER.

Witnesses:

HENRY CONNETT,
GEO. BAINTON.