

(12) UK Patent

(19) GB

(11) 2590790

(13) B

(45) Date of B Publication

20.04.2022

(54) Title of the Invention: **Infant highchair**

(51) INT CL: **A47D 1/08** (2006.01) **A47C 13/00** (2006.01) **A47D 1/00** (2006.01) **A47D 1/04** (2006.01)  
**A47D 1/10** (2006.01) **A47D 11/02** (2006.01)

(21) Application No: **2018007.1**

(22) Date of Filing: **05.07.2019**

Date Lodged: **16.11.2020**

(30) Priority Data:  
(31) **62695909** (32) **10.07.2018** (33) **US**

(62) Divided from Application No  
**1909685.8** under section 15(9) of the Patents Act 1977

(43) Date of A Publication **07.07.2021**

(72) Inventor(s):  
**Jonathan K Mountz**  
**Nathanael Saint**

(73) Proprietor(s):  
**Wonderland Switzerland AG**  
**Beim Bahnhof 5, Steinhausen 6312, Switzerland**

(74) Agent and/or Address for Service:  
**Marks & Clerk LLP**  
**Fletcher House (2nd Floor), Heatley Road,**  
**The Oxford Science Park, OXFORD, OX4 4GE,**  
**United Kingdom**

(56) Documents Cited:  
**US 20100096891 A1** **US 20060249994 A**  
**GB 191303024**

(58) Field of Search:  
As for published application 2590790 A viz:  
INT CL **A47C, A47D**  
Other: **WPI, EPODOC, INTERNET**  
updated as appropriate

Additional Fields  
Other: **None**

GB 2590790 B

100A

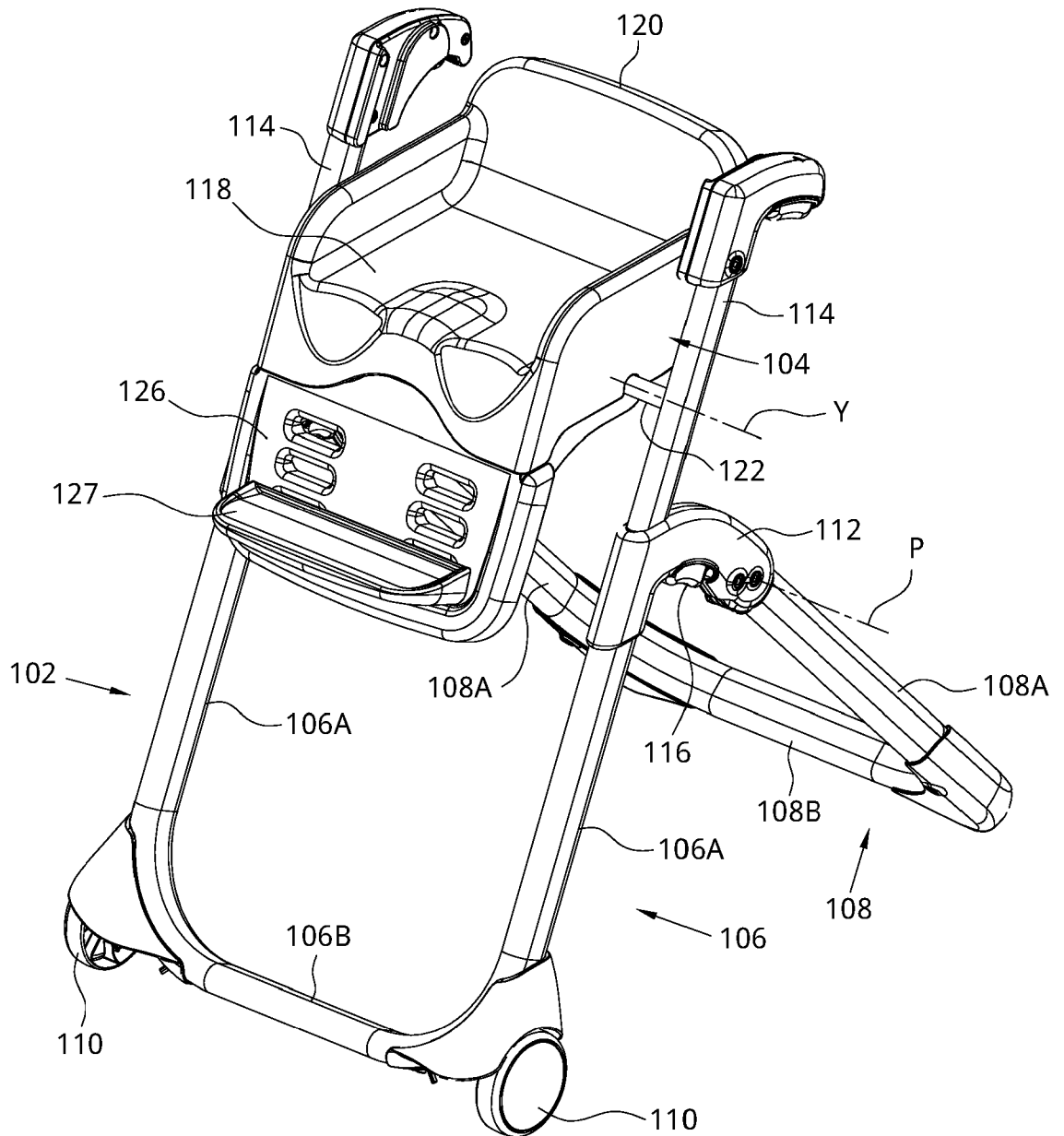

FIG. 1

100A

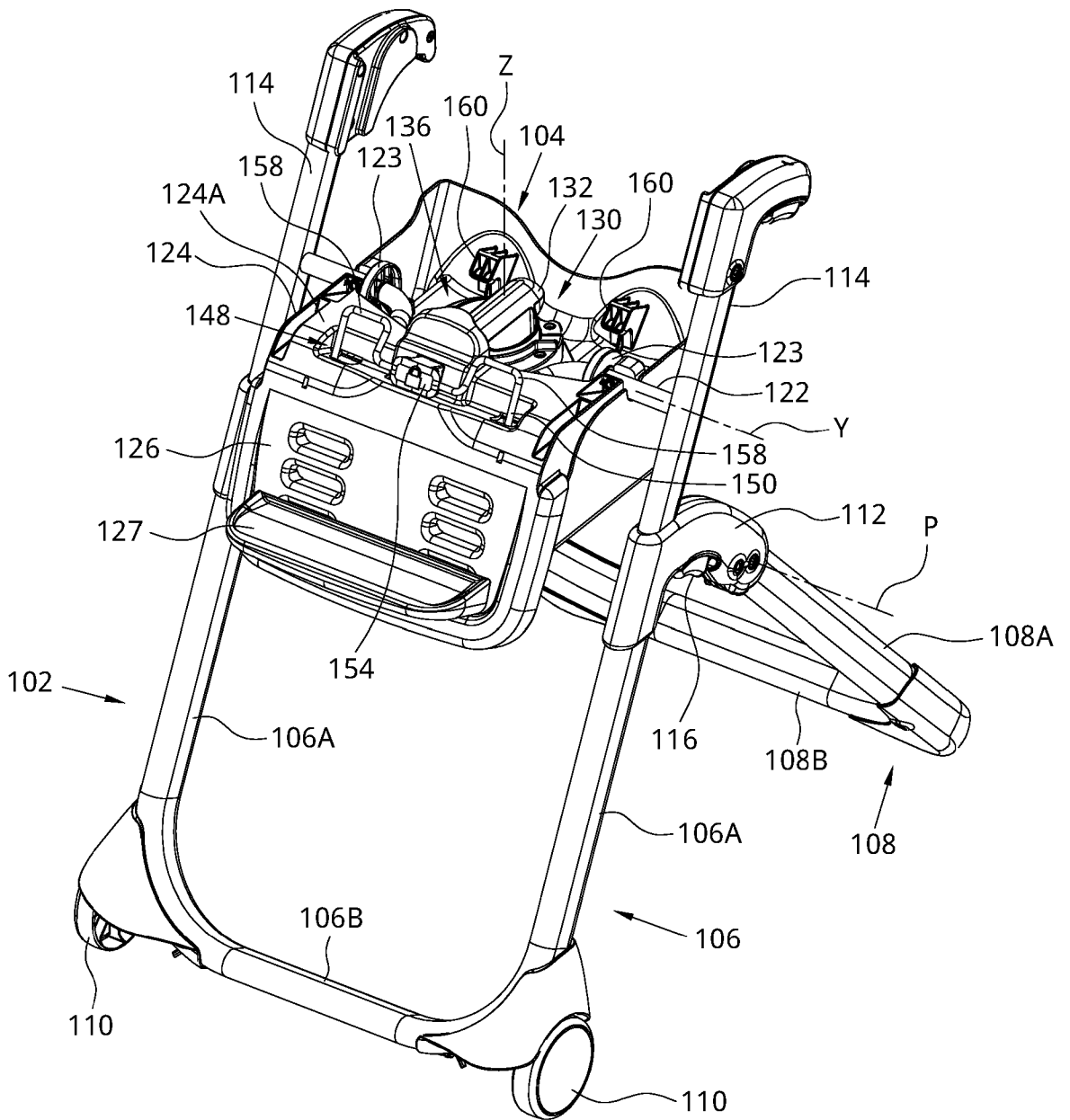

FIG. 2

100A

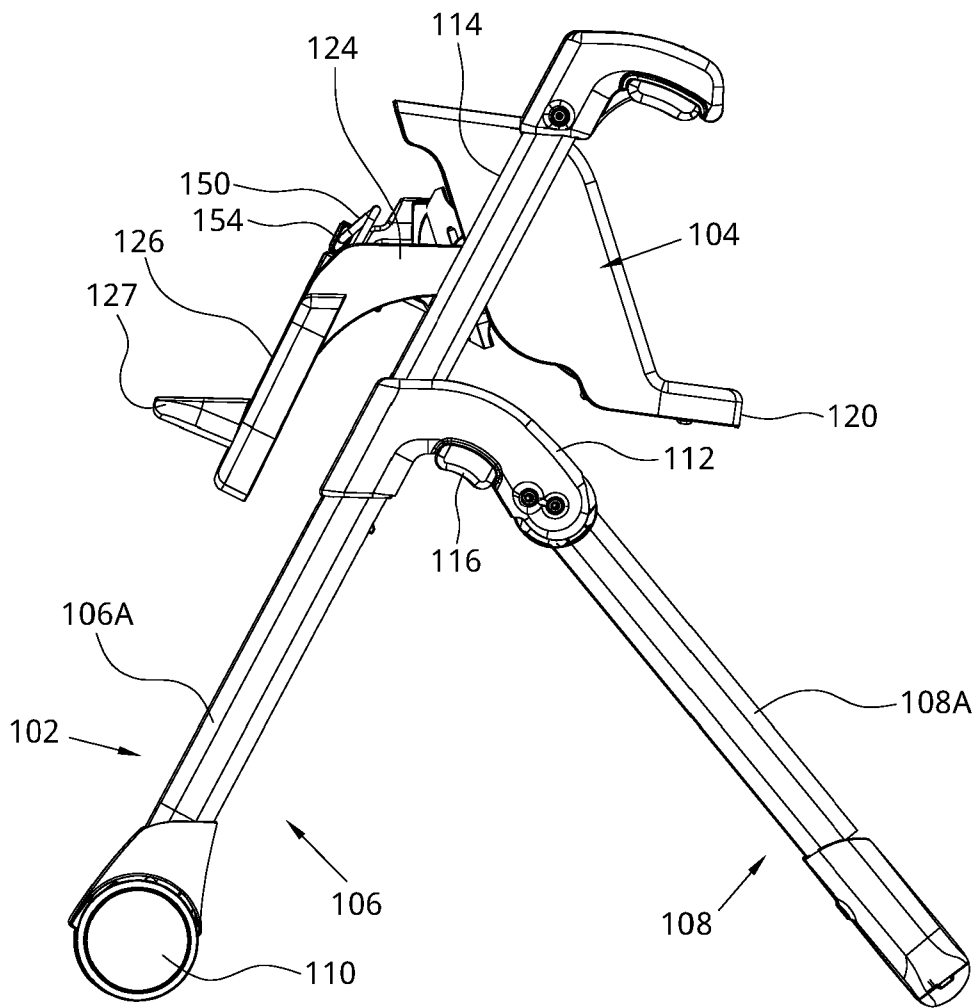

FIG. 3

100A

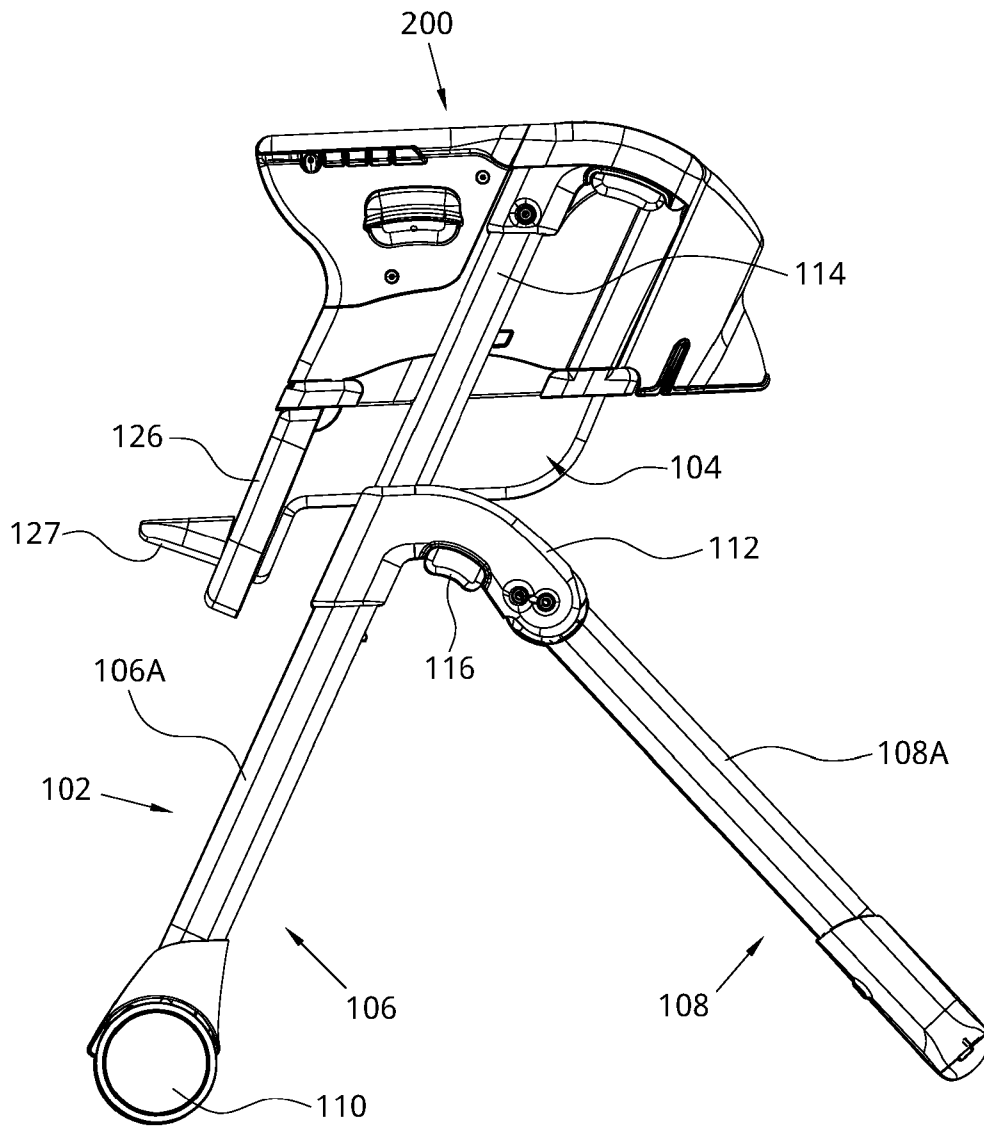

FIG. 4

100A

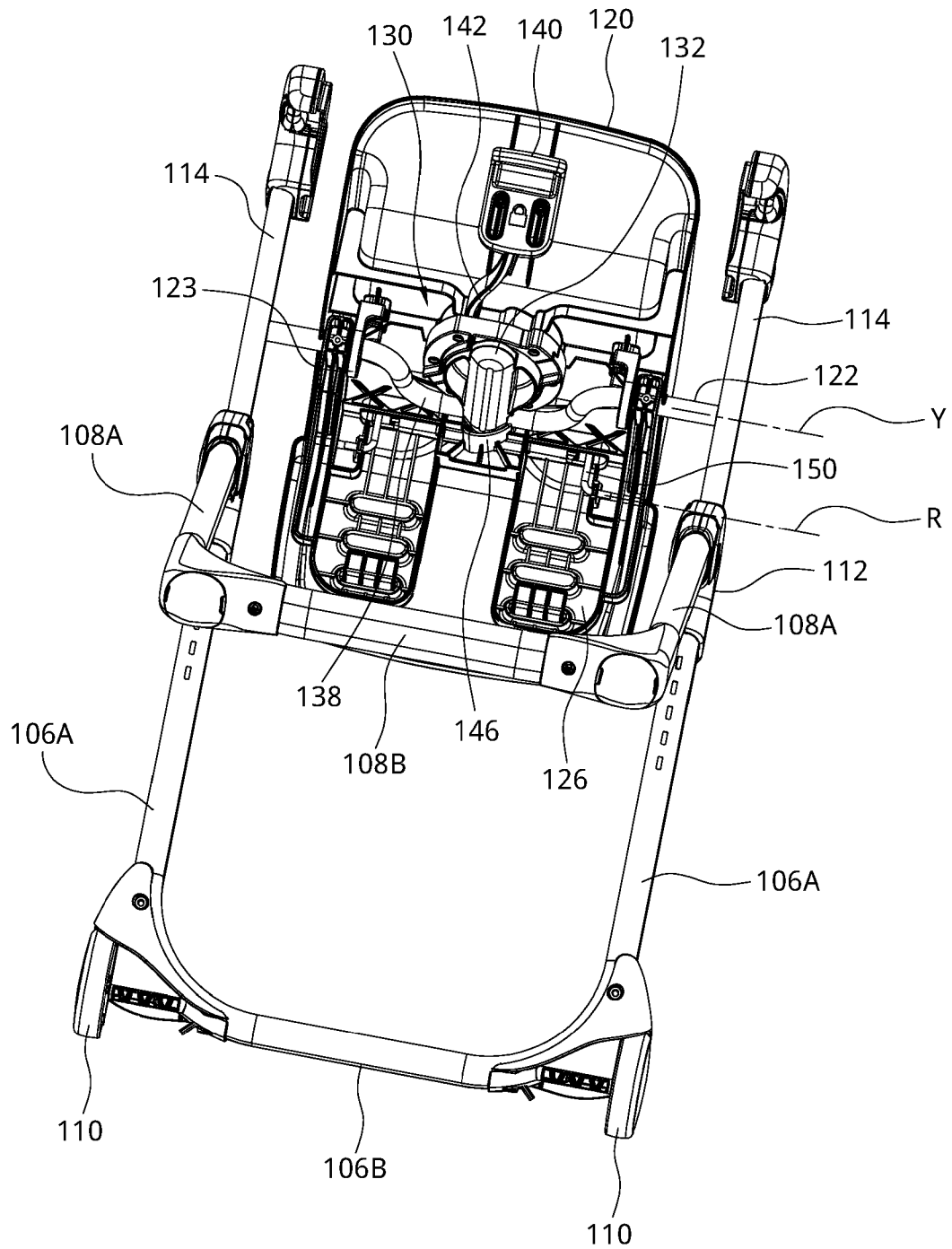

FIG. 5

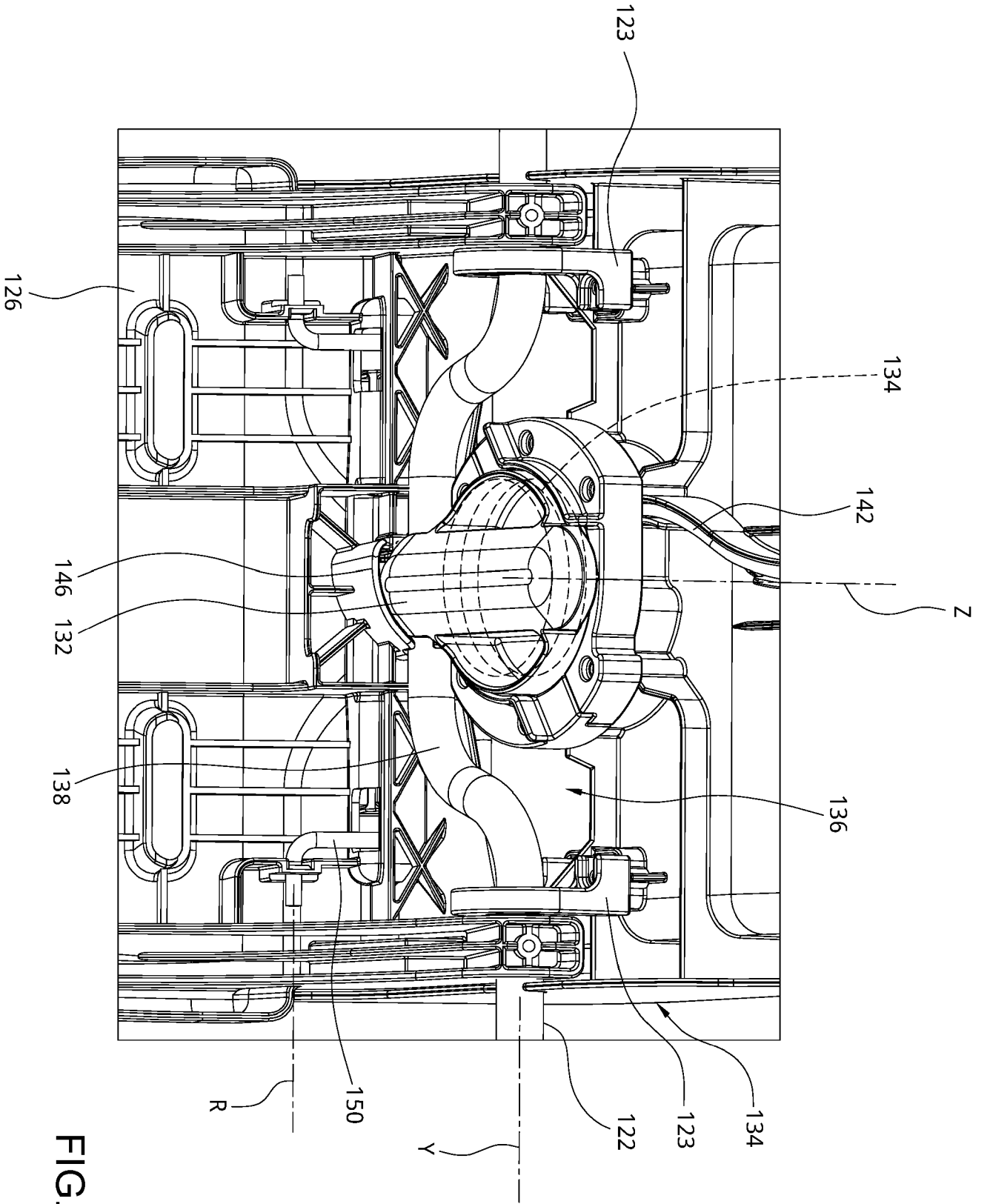

FIG. 6

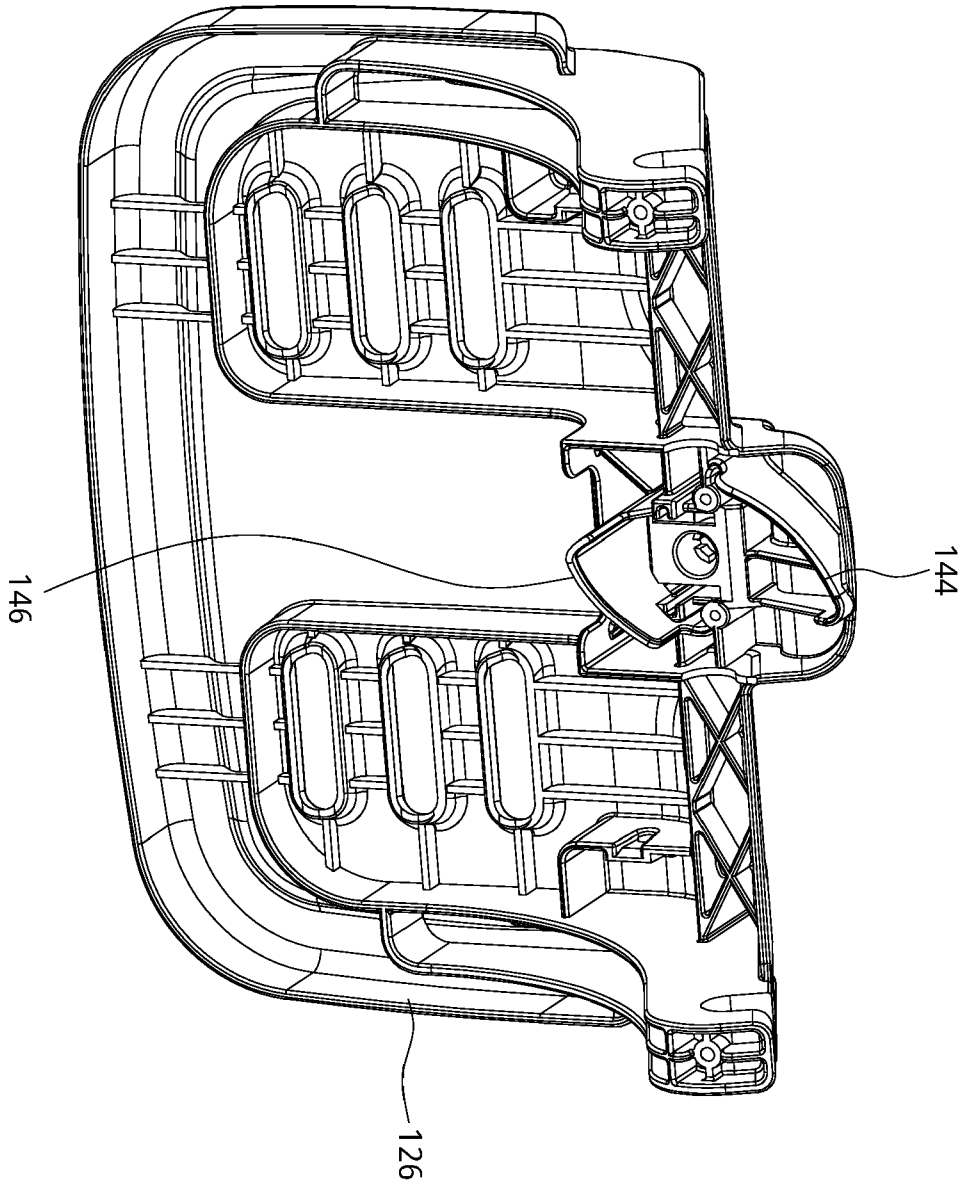

FIG. 7



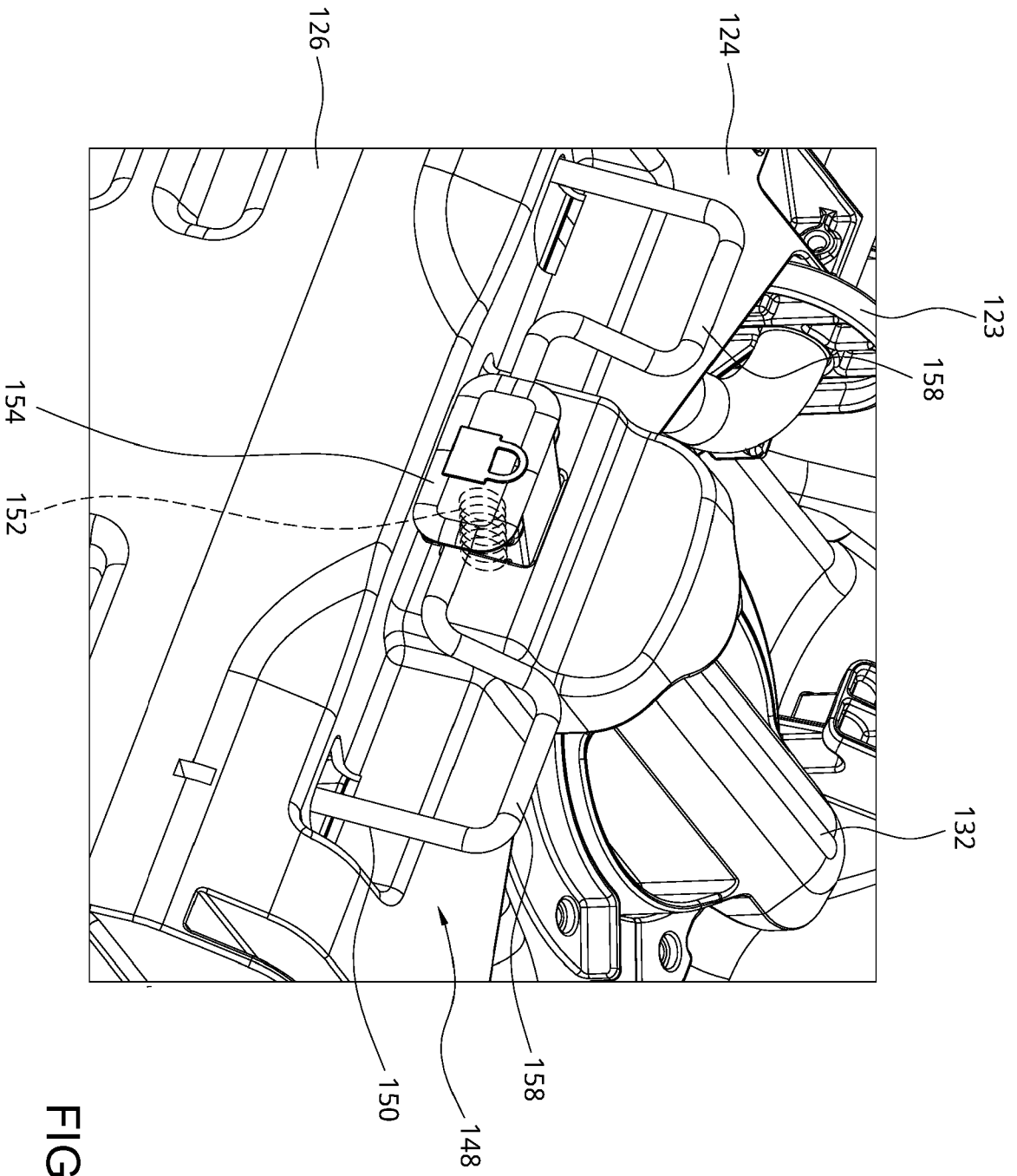

FIG. 8

100B

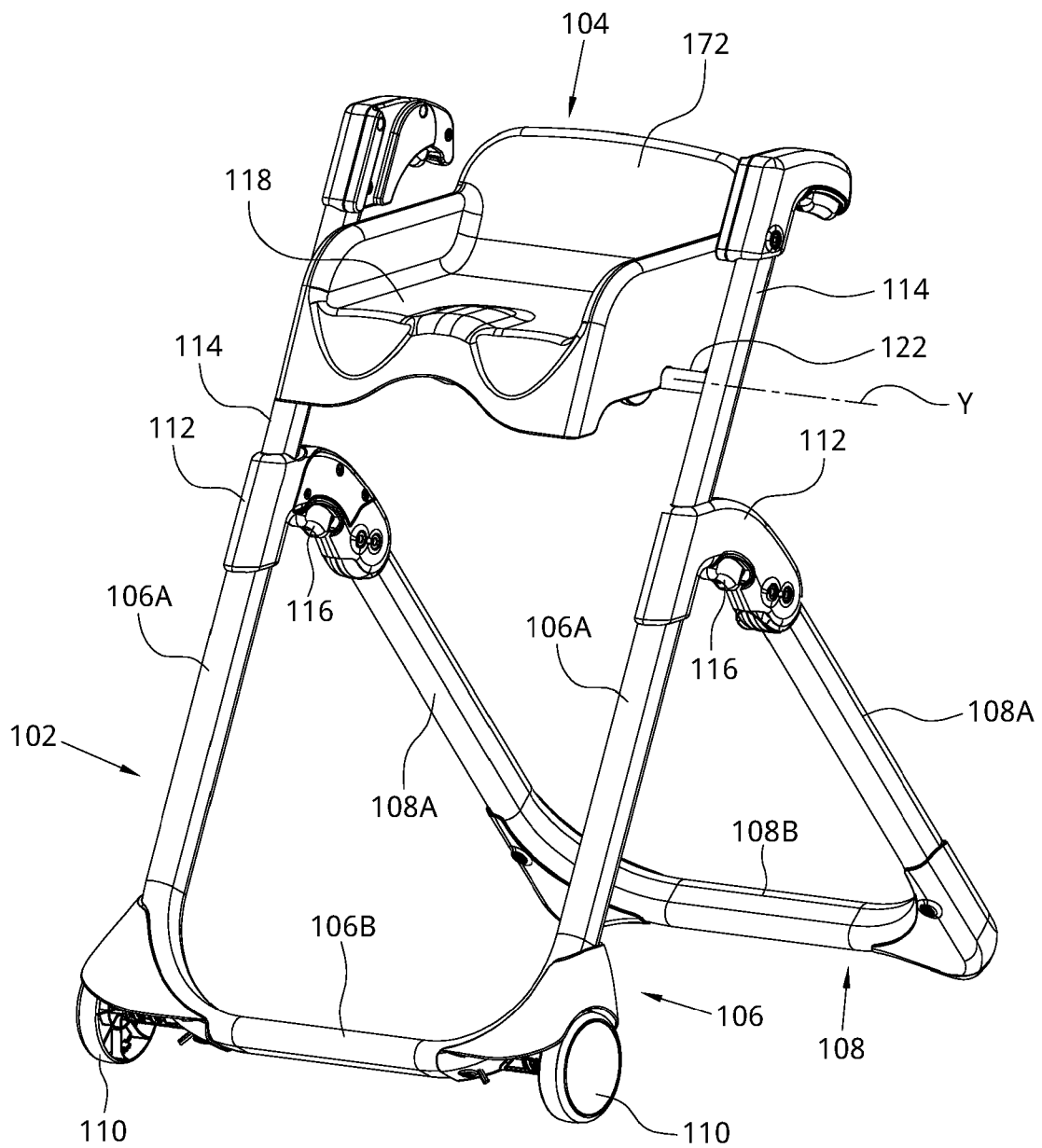

FIG. 9

100B

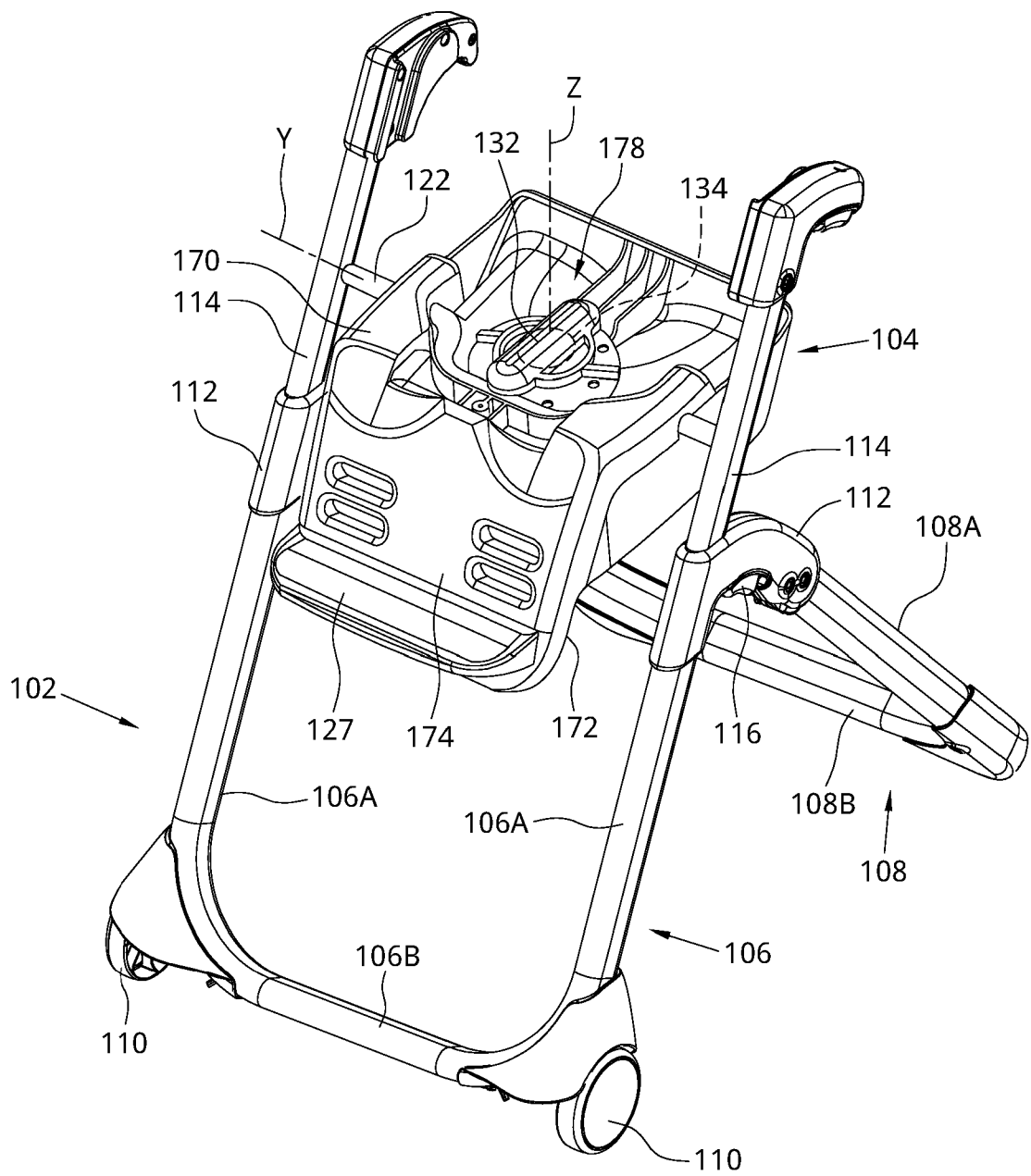

FIG. 10

# INFANT HIGHCHAIR

## CROSS-REFERENCE TO RELATED APPLICATION(S)

5 [0001] This application is a divisional application of G.B. patent application no. 1909685.8 filed on July 5, 2019, which claims priority to U.S. provisional application no. 62/695,909 filed on July 10, 2018.

## BACKGROUND

### [0002] 1. Field of the Invention

10 [0003] The present invention relates to infant highchairs.

### [0004] 2. Description of the Related Art

[0005] Some infant highchairs currently available on the market may have a seat and a tray that are removable from the highchair frame for use as a standalone infant booster seat. When the booster seat is removed from the highchair frame, there is no  
15 longer a usable seating surface on the highchair frame, which becomes useless.

[0006] Therefore, there is a need for an improved highchair for infants that can be more flexible in use and address at least the foregoing issues.

## SUMMARY

[0007] The present application describes an infant highchair having a seat rotatable  
20 to convert the infant highchair to multiple configurations of use.

[0008] According to one aspect, the infant highchair includes a standing frame including a support platform, a seat pivotally connected with the standing frame and having a seating surface, and a locking mechanism. The seat is rotatable between a first and a second position, the first position allowing a child to sit in contact with the seating surface, and the second position being suitable to receive installation of a removable child seat over the seat while disabling seating of a child on the seating surface, the seating surface moving around the support platform when the seat rotates relative to the standing frame, the second position of the seat uncovering the support platform so that a removable child seat is installable over the seat at least partially supported in contact with the support platform. The locking mechanism is operable to lock the seat in the first and second position.

### **BRIEF DESCRIPTION OF THE DRAWINGS**

[0009] FIG. 1 is a perspective view illustrating an embodiment of an infant high chair;

15 [0010] FIG. 2 is a perspective view illustrating the infant highchair of FIG. 1 in a different configuration;

[0011] FIG. 3 is a side view illustrating exemplary adjustment of the infant highchair between the two configurations shown in FIGS. 1 and 2;

[0012] FIG. 4 is a side view illustrating the infant highchair of FIG. 1 with a removable child seat installed over a seat of the infant highchair;

20

[0013] FIG. 5 is a perspective view illustrating further construction details of the infant highchair;

[0014] FIG. 6 is an enlarged view illustrating a locking mechanism provided in the infant highchair;

[0015] FIG. 7 is a perspective view illustrating a calf support portion provided in the infant highchair;

5 [0016] FIG. 8 is an enlarged view illustrating a portion of a safety mechanism provided in the infant highchair;

[0017] FIG. 9 is a perspective view illustrating another embodiment of an infant highchair; and

[0018] FIG. 10 is a perspective view illustrating the infant highchair of FIG. 9 in a  
10 different configuration.

### **DETAILED DESCRIPTION OF THE EMBODIMENTS**

[0019] FIGS. 1 and 2 are perspective views illustrating an embodiment of an infant highchair 100A in two different configurations, and FIG. 3 is a side view illustrating exemplary adjustment of the infant highchair 100A between the two configurations  
15 shown in FIGS. 1 and 2. Referring to FIGS. 1-3, the infant highchair 100A can include a standing frame 102 and a seat 104 assembled with each other.

[0020] The standing frame 102 can include a front leg portion 106 and a rear leg portion 108. The front leg portion 106 can have two leg segments 106A, and a transversal segment 106B connected between the two leg segments 106A near the lower  
20 ends thereof. Likewise, the rear leg portion 108 can have two leg segments 108A, and a transversal segment 108B connected between the two leg segments 108A near the lower

ends thereof. Moreover, a plurality of wheels 110 can be respectively provided on at least the front leg portion 106 to facilitate transport of the infant highchair 100A.

**[0021]** The front leg portion 106 can be pivotally connected with the rear leg portion 108 about a pivot axis P. For example, two coupling parts 112 can respectively connect pivotally the two leg segments 106A of the front leg portion 106 with the two leg segments 108A of the rear leg portion 108 about the pivot axis P. The two coupling parts 112 can be similar in construction and can be arranged at a left and right side of the standing frame 102. For example, each coupling part 112 can be slidably connected with one corresponding leg segment 106A of the front leg portion 106, and pivotally connected with one corresponding leg segment 108A of the rear leg portion 108. The coupling parts 112 can respectively slide along the leg segments 106A of the front leg portion 106 to adjust a height of the infant highchair 100A. Each leg segment 106A of the front leg portion 106 can respectively extend outside the corresponding coupling part 112 at two opposite sides thereof so that each leg segment 106A can have an upper portion 114 located above the coupling part 112 when the infant highchair 100A stands on a floor surface.

**[0022]** According to an example of construction, each coupling part 112 can include a latch (not shown) operable to lock the standing frame 102 in an unfolded state for use and unlock the standing frame 102 for folding of the infant highchair 100A. A release actuator 116 exposed outward for operation may be connected with the latch of the coupling part 112 via a cable (not shown), whereby the release actuator 116 is operable to cause the latch to unlock for rotation of the front leg portion 106 relative to the rear leg portion 108.

[0023] Referring to FIGS. 1 and 2, the seat 104 can have a seating surface 118 and a backrest portion 120, and is suitable to receive a child sitting in contact with the seating surface 118 with the child's back supported by the backrest portion 120. According to an example of construction, the seat 104 including the seating surface 118 and the backrest portion 120 may be formed integrally as a unitary part. The seat 104 is pivotally connected with the standing frame 102 about a pivot axis Y. For example, the upper portions 114 of the leg segments 106A can be respectively connected fixedly with a bar segment 122 extending transversally from a left to a right side of the standing frame 102, and the seat 104 can be pivotally connected with the bar segment 122 for rotation about the pivot axis Y. The pivot connection of the seat 104 can exemplarily include assembling the bar segment 122 through two pivot brackets 123 that are fixedly connected with the seat 104. The seat 104 is thereby rotatable relative to the standing frame 102 between multiple positions corresponding to different configurations of use. For example, the seat 104 may be rotated to a first position where the seating surface 118 faces upward, which allows a child to sit on the seat 104 in contact with the seating surface 118. The first position of the seat 104 is shown in FIG. 1, and can correspond to a first configuration of use in which a child can directly sit on the seat 104 integrated with the infant highchair 100A.

[0024] Moreover, the seat 104 may be rotated to a second position where the seating surface 118 faces downward, which is suitable to receive the installation of a removable child seat over the seat 104 while disabling seating of a child on the seating surface 118. The second position of the seat 104 is shown in FIG. 2, and can correspond to a second configuration of use in which a removable child seat can be installed on the infant highchair 100A for seating a child thereon. FIG. 3 is a side view illustrating the seat 104



rotated to an intermediate angular position between the first and second position, and FIG. 4 is a side view illustrating a removable child seat 200 installed over the seat 104 in the second position. Examples of removable child seats installable on the infant highchair 100A in the second configuration of use can include, without limitation, booster seats.

**[0025]** As better shown in FIG. 2, the standing frame 102 may include a support platform 124 configured to receive the mount of a removable child seat when the seat 104 is in the second position. The support platform 124 may be assembled with the leg segments 106A in a region between the upper portions 114 of the leg segments 106A. For example, the support platform 124 may be fixedly attached to the bar segment 122.

**[0026]** The seating surface 118 of the seat 104 can move around the support platform 124 when the seat 104 rotates relative to the standing frame 102. For example, the seating surface 118 can be located above the support platform 124 when the seat 104 is in the first position and below the support platform 124 when the seat 104 is in the second position. When the seat 104 is in the first position, the support platform 124 is upwardly covered by the seat 104, which disables mounting of a removable child seat on the support platform 124. When the seat 104 is in the second position, the seat 104 can uncover the support platform 124, which allows a removable child seat to be installed over the seat 104 at least partially supported by and in contact with the support platform 124. For example, the support platform 124 can have an upper surface 124A configured to restrictedly position and support the removable child seat. Structures that may be provided on the upper surface 124A of the support platform 124 for engagement

of a removable child seat may include, without limitation, recesses, protrusions and the like.

**[0027]** According to an example of construction, the standing frame 102 can further include a calf support portion 126 fixedly connected with the support platform 124. The calf support portion 126 may be formed integrally with the support platform 124 as a unitary part, or may be fixedly attached to the support platform 124 via a fastener. During use, the seat 104 can rotate relative to the standing frame 102 and the calf support portion 126 between the first and second position, and the calf support portion 126 is adapted to provide support for the calves of a child in both the first and second configurations of use corresponding to the first and second positions of the seat 104. For example, the calf support portion 126 can extend downward from a front of the seating surface 118 of the seat 104 when the seat 104 is in the first position (as better shown in FIG. 1), and can extend downward from a front of a removable child seat 200 installed on the support platform 124 when the seat 104 is in the second position (as better shown in FIG. 4). The backrest portion 120 of the seat 104 may be disposed adjacent to the calf support portion 126 when the seat 104 is in the second position. In addition, the calf support portion 126 may include a footrest 127 adapted to support the feet of a child. According to an example of construction, the position of the footrest 127 on the calf support portion 126 may be adjustable according to the length of the child's legs.

**[0028]** In conjunction with FIGS. 1-4, FIG. 5 is a perspective view illustrating further construction details of the infant highchair 100A, and FIG. 6 is an enlarged view illustrating a locking mechanism 130 provided in the infant highchair 100A. Referring to FIGS. 1-6, the infant highchair 100A further includes a locking mechanism 130

operable to lock the seat 104 in the first and second position. The locking mechanism 130 can include a latch 132 and a spring 134 (shown with phantom lines in FIG. 6).

**[0029]** According to an example of construction, the latch 132 can be assembled with the seat 104. For example, the latch 132 can be disposed centrally in a cavity 136  
5 of the seat 104, and can be pivotally connected with the seat 104 about a pivot axis Z. The pivot axis Z can extend substantially vertically when the infant highchair 100A stands on a floor surface and the seat 104 is in any of the first and second positions. The latch 132 can engage with the standing frame 102 to lock the seat 104 in the first and second position, and disengage from the standing frame 102 to unlock the seat 104 for  
10 rotation of the seat 104 between the first and second position. For example, the latch 132 can engage with and disengage from the bar segment 122 for locking and unlocking the seat 104. More specifically, the latch 132 may engage with a first side of the bar segment 122 of the standing frame 102 to lock the seat 104 in the first position, and may engage with a second side of the bar segment 122 opposite to the first side to lock the  
15 seat 104 in the second position. According to an example of construction, the bar segment 122 may have a bending portion 138 at a central location of the bar segment 122 that protrudes away from the pivot axis Y of the seat 104, and the latch 132 is rotatable relative to the seat 104 generally parallel to the bar segment 122 between a locking state engaged with the bending portion 138 for locking the seat 104 in the first  
20 or second position, and an unlocking state disengaged from the bending portion 138 for unlocking the seat 104. When the latch 132 is engaged with the bar segment 122, the bending portion 138 of the bar segment 122 may be restrictedly held between the latch 132 at one side and the seat 104 at an opposite side.

[0030] Referring to FIG. 6, the spring 134 can be respectively connected with the latch 132 and the seat 104. According to an example of construction, the spring 134 may be a torsion spring disposed around the pivot axis Z of the latch 132. The spring 134 can apply a biasing action that urges the latch 132 toward the locking state for locking engagement with the bar segment 122 of the standing frame 102.

[0031] According to an example of construction, the latch 132 may be exposed so that a caregiver can directly operate the latch 132 with a hand for unlocking the seat 104. According to another example of construction, the locking mechanism 130 may further include a release actuator 140 (better shown in FIG. 5) that is remotely connected with the latch 132 and is operable to cause the latch 132 to unlock the seat 104. For example, the release actuator 140 may be slidably disposed on the backrest portion 120 of the seat 104, and may be connected with the latch 132 via a cable 142. The release actuator 140 is operable to pull on the cable 142, which in turn urges the latch 132 to rotate from the locking state to the unlocking state for disengaging from the bar segment 122 of the standing frame 102.

[0032] In case a caregiver releases the release actuator 140 or the latch 132 during adjustment of the seat 104 between the first and second position, the latch 132 may recover a position corresponding to the locking state owing to the biasing action of the spring 134. Referring to FIGS. 5-7, the standing frame 102 may include two cam surfaces 144 and 146 configured to displace the latch 132 for facilitating self-locking of the seat 104 in the first and second position. The cam surfaces 144 and 146 can be fixedly connected with the support platform 124 (e.g., adjacent to the calf support portion 126) at two opposite sides of the bending portion 138, and can respectively face

the latch 132. According to an example of construction, each of the cam surfaces 144 and 146 can respectively be shaped as a portion of a spiral.

**[0033]** The cam surface 144 may be disposed above the bending portion 138 of the bar segment 122, and may be able to contact and push the latch 132 in movement  
5 against the biasing action of the spring 134 as the seat 104 approaches the first position for facilitating continued rotation of the seat 104 to the first position. Once the seat 104 reaches the first position, the latch 132 can disengage from the cam surface 144 and can be urged by the spring 134 to engage with the bending portion 138 of the bar segment 122 for locking the seat 104 in position.

10 **[0034]** The cam surface 146 may be disposed below the bending portion 138 of the bar segment 122, and may be able to contact and push the latch 132 in movement against the biasing action of the spring 134 as the seat 104 approaches the second position for facilitating continued rotation of the seat 104 to the second position. Once the seat 104 reaches the second position, the latch 132 can disengage from the cam  
15 surface 146 and can be urged by the spring 134 to engage with the bending portion 138 of the bar segment 122 for locking the seat 104 in position.

**[0035]** Referring to FIGS. 2, 3, 5 and 6, the infant highchair 100A can further include a safety mechanism 148 configured to prevent accidental rotation of the seat 104 from the first position to the second position. FIG. 8 is an enlarged view illustrating  
20 a portion of the safety mechanism 148. Referring to FIGS. 2, 3, 5, 6 and 8, according to an example of construction, the safety mechanism 148 can include an impeding part 150, a spring 152 (shown with phantom lines in FIG. 8) and a release actuator 154. The impeding part 150 may be movably assembled with the standing frame 102. For

example, the impeding part 150 may be pivotally connected with the standing frame 102, e.g., with the support platform 124 or the calf support portion 126 of the standing frame 102. According to an example of construction, the impeding part 150 can include a rod extending generally transversally along a width direction of the seat 104 that has two opposite ends pivotally connected with the calf support portion 126 of the standing frame 102. The impeding part 150 can thereby rotate about a pivot axis R that extends transversally from a left side to a right side of the seat 104 between a hindering position and a release position. According to an example of construction, the impeding part 150 may be disposed adjacent to the calf support portion 126.

10 **[0036]** The impeding part 150 is configured to engage with the seat 104 for forcing the seat 104 to stop at an intermediate position during a rotation of the seat 104 from the first position toward the second position while allowing continuous rotation of the seat 104 from the second position past the intermediate position to the first position. For example, the impeding part 150 may have two bending portions 158 that protrude upward above the bar segment 122 and the support platform 124 and are radially offset from the pivot axis R of the impeding part 150, and the seat 104 can have two hooks 160 (better shown in FIG. 2) that are movable along with the seat 104 and can respectively engage with and disengage from the two bending portions 158. During rotation of the seat 104 from the first position toward the second position, the hindering position of the impeding part 150 can force the seat 104 to stop at an intermediate position between the first and second position owing to the engagement between the hooks 160 and the bending portions 158. This intermediate position can be exemplary at an angle of about 15 degrees from the first position. During rotation of the seat 104 from the second position toward the first position, the hooks 160 can respectively

contact and push against the bending portions 158 so that the impeding part 150 is forced by the seat 104 to rotate from the hindering position to the release position to allow continuous travel of the seat 104 past the intermediate position to the first position.

5 **[0037]** The spring 152 is shown with phantom lines in the enlarged view of FIG. 8. Referring to FIGS. 2 and 8, the spring 152 can be configured to bias the impeding part 150 toward the hindering position. According to an example of construction, the spring 152 may be a compression spring respectively connected with the standing frame 102 (e.g., the support platform 124 or the calf support portion 126 of the standing frame 102) and the impeding part 150. More specifically, the spring 152 may be exemplarily  
10 disposed adjacent to the release actuator 154.

**[0038]** The release actuator 154 can be connected with the impeding part 150. For example, the release actuator 154 may be fixedly connected with the impeding part 150 at a middle location between the two bending portions 158. The release actuator 154 is  
15 operable to cause the impeding part 150 to rotate from the hindering position to the release position against the biasing force of the spring 152, which can disengage the bending portions 158 of the impeding part 150 from the hooks 160 of the seat 104.

**[0039]** Exemplary operation of the safety mechanism 148 is described hereinafter with reference to FIGS. 1-8. When the seat 104 is to be adjusted from the first position  
20 to the second position, the release actuator 140 can be operated so as to cause the latch 132 to unlock the seat 104. Then the unlocked seat 104 can be rotated from the first position toward the second position. As the seat 104 rotates toward the second position and reaches the intermediate position, the hooks 160 of the seat 104 can come into

engagement with the impeding part 150 that is kept in the hindering position owing to the biasing force of the spring 152. As a result, the seat 104 is forced to stop at the intermediate position. The release actuator 154 may be concealed when the seat 104 is in the first position, and become exposed for operation at a front of the seat 104 when  
5 the seat 104 is in the intermediate position. For further rotating the seat 104 from the intermediate position to the second position, a caregiver has to operate the release actuator 154 to cause the impeding part 150 to rotate from the hindering position to the release position and disengage from the seat 104. Once the seat 104 is released from the hold of the impeding part 150, the seat 104 can be rotated from the intermediate  
10 position to the second position. By requiring a caregiver's manual operation for disengaging the impeding part 150 from the seat 104, the safety mechanism 148 can prevent accidental rotation of the seat 104 to the second position.

**[0040]** When the seat 104 is to be adjusted from the second position to the first position, the release actuator 140 can be operated to unlock the seat 104 like described  
15 previously. Then the unlocked seat 104 can be rotated from the second position toward the first position. As the seat 104 rotates toward the second position and approaches the intermediate position, the hooks 160 of the seat 104 can have respective ramp surfaces 160A that contact and push against the bending portions 158 of the impeding part 150 so that the impeding part 150 is urged to rotate from the hindering position to the  
20 release position against the biasing force of the spring 152. Accordingly, the safety mechanism 148 allows continuous rotation of the seat 104 from the second position past the intermediate position to the first position without the need of operating the release actuator 154.



[0041] FIGS. 9 and 10 are perspective views illustrating another embodiment of an infant highchair 100B. Referring to FIGS. 9 and 10, the infant highchair 100B may have the same standing frame 102 like described previously. Compared to the infant highchair 100A of the previous embodiment, the infant highchair 100B has a different construction of the seat 104 and does not include the support platform 124. More specifically, the seat 104 of the infant highchair 100B can have the seating surface 118 for receiving direct sitting of a child, and can further include a mount surface 170 suitable to receive the installation of a removable child seat. The seating surface 118 and the mount surface 170 can be located at two opposite sides of the seat 104. Moreover, the seat 104 can further include a protruding portion on which a backrest portion 172 and a calf support portion 174 are provided. The backrest portion 172 and the calf support portion 174 can be disposed adjacent to each other and face two opposite directions. Moreover, the calf support portion 174 may have the footrest 127. The seat 104 including the seating surface 118, the mount surface 170, the backrest portion 172 and the calf support portion 174 may be provided as a unitary part. Accordingly, the seating surface 118, the mount surface 170, the backrest portion 172 and the calf support portion 174 can move in unison when the seat 104 rotates relative to the standing frame 102.

[0042] Like described previously, the seat 104 can be pivotally connected with the standing frame 102 about the bar segment 122, which can extend between the seating surface 118 and the mount surface 170 of the seat 104. The seat 104 of the infant highchair 100B is thereby rotatable between multiple positions corresponding to different configurations of use. For example, the seat 104 can be rotated to a first position (shown in FIG. 9) corresponding to a first configuration of use where a child

can sit on the seat 104 in contact with the seating surface 118, and a second position (shown in FIG. 10) corresponding to a second configuration of use where a removable child seat can be installed on the seat 104 in contact with the mount surface 170 thereof.

5 **[0043]** Referring to FIGS. 9 and 10, the infant highchair 100B can further include a locking mechanism 178 operable to lock the seat 104 in the first and second position. The locking mechanism 178 can include the same latch 132 and spring 134 (shown with phantom lines in FIG. 10) provided in the infant highchair 100A. Like previously described, the latch 132 may be pivotally connected with the seat 104 about the pivot axis Z, and can rotate to engage and disengage two opposite sides of the bar segment 10 122 for locking or unlocking the seat 104 in the first and second positions. The spring 134 can be exemplary a torsion spring disposed around the pivot axis Z of the latch 132, and can be respectively connected with the latch 132 and the seat 104. The spring 134 can apply a biasing action that urges the latch 132 toward a locking state for locking engagement with the bar segment 122 of the standing frame 102.

15 **[0044]** According to an example of construction, the latch 132 may be exposed so that a caregiver can directly operate the latch 132 with a hand for unlocking the seat 104. According to another example of construction, the latch 132 may be connected with a release actuator (not shown) that is operable to cause the latch 132 to unlock the seat 104.

20 **[0045]** Exemplary operation of the infant highchair 100B will be described hereinafter with reference to FIGS. 9 and 10. When the seat 104 is in the first position shown in FIG. 9, the seating surface 118 can face upward and the backrest portion 172 can face forward and extend above the seating surface 118, which allows a child to sit

on the seat 104 in contact with the seating surface 118 with the child's back resting against the backrest portion 172. The seat 104 can be locked in the first position by the engagement of the latch 132 with a first side of the bar segment 122 like described previously. The first position of the seat 104 can correspond to a first configuration of use in which a child can directly sit on the seat 104 integrated with the infant highchair 100B. In the first position, the mount surface 170 can face downward, which disables the use of the mount surface 170 for installing a removable child seat. Moreover, the calf support portion 174 can be positioned at a rear when the seat 104 is in the first position, which disables the use of the calf support portion 174 for supporting the calves of a child sitting on the seating surface 118.

**[0046]** For installing a removable child seat on the infant highchair 100B, the latch 132 can be operated to disengage from the bar segment 122 and thereby unlock the seat 104, and the seat 104 then can be rotated about the pivot axis Y to the second position shown in FIG. 10. When the seat 104 is in the second position, the seating surface 118 can face downward and the mount surface 170 can face upward, which is suitable to receive installation of a removable child seat on the seat 104 in contact with the mount surface 170 while disabling seating of a child on the seating surface 118. The seat 104 can be locked in the second position by the engagement of the latch 132 with a second side of the bar segment 122 opposite to the first side. The second position of the seat 104 can correspond to a second configuration of use in which a removable child seat can be installed on the infant highchair 100B for seating a child, the removable child seat being engaged with and supported by the seat 104. In the second position, the calf support portion 174 can extend downward from a front of the mount surface 170, which

can provide support for the calves of a child who sits on the removable child seat installed on the mount surface 170.

**[0047]** Advantages of the structures described herein include the ability to provide an infant highchair that has a seat rotatable between multiple positions corresponding to different configurations of use. The seat may be adjusted to a first position  
5 corresponding to a configuration of use where a child can directly sit on the seat, and a second position corresponding to another configuration of use where a removable child seat can be installed over the seat for seating a child on the removable child seat. Accordingly, the infant highchair described herein can provide a more flexible use and  
10 may be adapted to receive children of different ages.

**[0048]** The invention may include one or more of the following numbered embodiments:

1. An infant highchair comprising: a standing frame; a seat pivotally connected with the standing frame and having a seating surface, the seat being rotatable between a  
15 first and a second position, the first position allowing a child to sit in contact with the seating surface, and the second position being suitable to receive installation of a removable child seat over the seat while disabling seating of a child on the seating surface; and a locking mechanism operable to lock the seat in the first and second position.
- 20 2. The infant highchair according to embodiment 1, wherein the standing frame includes a support platform, and the seating surface moves around the support platform when the seat rotates relative to the standing frame, the second position of the seat uncovering the support platform so that a removable child seat is installable over the seat at least partially supported in contact with the support platform.
- 25 3. The infant highchair according to embodiment 2, wherein the seating surface is

located above the support platform in the first position and below the support platform in the second position.

4. The infant highchair according to embodiment 2 or 3, wherein the standing frame has a calf support portion fixedly connected with the support platform.

5 5. The infant highchair according to embodiment 1, wherein the seat further has a mount surface suitable to receive installation of a removable child seat, the first position of the seat allowing a child to sit on the seat in contact with the seating surface, and the second position of the seat allowing installation of a removable child seat on the seat in contact with the mount surface.

10 6. The infant highchair according to embodiment 5, wherein the seating surface and the mount surface are located at two opposite sides of the seat, the seating surface facing upward in the first position, and the mount surface facing upward in the second position.

15 7. The infant highchair according to embodiment 1, 5 or 6, wherein the seat has a backrest portion and a calf support portion disposed adjacent to each other that face two opposite directions, the backrest portion being configured to provide resting support for a child's back when the seat is in the first position, and the calf support portion being configured to provide support for the calves of a child when the seat is in the second position.

20 8. The infant highchair according to embodiment 1, wherein the locking mechanism includes a latch that is assembled with the seat, the latch being engaged with the standing frame to lock the seat in the first and second position and disengaged from the standing frame to unlock the seat for rotation of the seat between the first and second position.

25 9. The infant highchair according to embodiment 8, wherein the standing frame includes a bar segment, and the latch respectively engages with a first side of the bar segment to lock the seat in the first position and with a second side of the bar segment

opposite to the first side to lock the seat in the second position.

10. The infant highchair according to embodiment 9, wherein the seat is pivotally connected about the bar segment.

11. The infant highchair according to embodiment 9 or 10, wherein the latch is  
5 pivotally connected with the seat, and the bar segment has a bending portion, the latch being rotatable relative to the seat between a locking state engaged with the bending portion for locking the seat in the first or second position, and an unlocking state disengaged from the bending portion for unlocking the seat.

12. The infant highchair according to any of embodiments 8 to 11, wherein the latch  
10 is pivotally connected with the seat about a pivot axis that extends substantially vertically when the infant highchair stands on a floor surface.

13. The infant highchair according to any of embodiments 8 to 12, wherein the locking mechanism further includes a spring and a release actuator respectively connected with the latch, the spring applying a biasing action that urges the latch toward  
15 a locking state for locking engagement with the standing frame, and the release actuator being operable to cause the latch to disengage from the standing frame for unlocking the seat.

14. The infant highchair according to embodiment 13, wherein the standing frame includes a first and a second cam surface, the first cam surface being adapted to contact  
20 and push the latch in movement against the biasing action of the spring as the seat approaches the first position for facilitating continued rotation of the seat to the first position, and the second cam surface being adapted to contact and push the latch in movement against the biasing action of the spring as the seat approaches the second position for facilitating continued rotation of the seat to the second position, the latch  
25 being disengaged from the first cam surface when the seat reaches the first position and disengaged from the second cam surface when the seat reaches the second position.

15. The infant highchair according to embodiment 13 or 14, wherein the release

actuator is disposed on a backrest portion of the seat and is connected with the latch via a cable.

16. The infant highchair according to any of embodiments 8 to 15, further including an impeding part assembled with the standing frame, and a second release actuator  
5 connected with the impeding part, the impeding part being configured to engage with the seat for forcing the seat to stop at an intermediate position during a rotation of the seat from the first position toward the second position while allowing continuous rotation of the seat from the second position past the intermediate position to the first position, and the second release actuator being operable to cause the impeding part to  
10 disengage from the seat in the intermediate position for rotation of the seat from the intermediate position to the second position.

17. The infant highchair according to embodiment 16, wherein the second release actuator is concealed when the seat is in the first position, and becomes exposed for operation when the seat is in the intermediate position.

18. The infant highchair according to embodiment 16, wherein the impeding part is  
15 pivotally connected with the standing frame, and the seat has a hook movable along with the seat, the hook coming into engagement with the impeding part to force the seat to stop in the intermediate position during a rotation of the seat from the first position toward the second position.

19. An infant highchair comprising: a standing frame having a calf support portion;  
20 a seat pivotally connected with the standing frame and having a seating surface, the seat being rotatable relative to the standing frame and the calf support portion between a first and a second position, the first position allowing a child to sit in contact with the seating surface, and the second position being suitable to receive installation of a removable  
25 child seat over the seat while disabling seating of a child on the seating surface; and a locking mechanism operable to lock the seat in the first and second position.

20. The infant highchair according to embodiment 19, wherein the standing frame

further includes a support platform fixedly connected with the calf support portion, and the seating surface moves around the support platform when the seat rotates relative to the standing frame and the calf support portion, the second position of the seat uncovering the support platform so that a removable child seat is installable over the seat at least partially supported in contact with the support platform.

21. The infant highchair according to embodiment 20, wherein the seating surface is located above the support platform in the first position and below the support platform in the second position.

22. The infant highchair according to embodiment 19, 20 or 21, wherein the locking mechanism includes a latch that is assembled with the seat, the latch being engaged with the standing frame to lock the seat in the first and second position and disengaged from the standing frame to unlock the seat for rotation of the seat between the first and second position.

23. The infant highchair according to embodiment 22, wherein the standing frame includes a bar segment, and the latch respectively engages with a first side of the bar segment to lock the seat in the first position and with a second side of the bar segment opposite to the first side to lock the seat in the second position.

24. The infant highchair according to embodiment 23, wherein the seat is pivotally connected about the bar segment.

25. The infant highchair according to embodiment 22, 23 or 24, wherein the locking mechanism further includes a spring and a release actuator respectively connected with the latch, the spring applying a biasing action that urges the latch toward a locking state for locking engagement with the standing frame, and the release actuator being operable to cause the latch to disengage from the standing frame for unlocking the seat.

26. An infant highchair comprising: a standing frame; a seat pivotally connected with the standing frame, wherein the seat includes a seating surface, and a backrest portion and a calf support portion disposed adjacent to each other that face two opposite



directions, the seat being rotatable relative to the standing frame between a first and a second position, the first position allowing a child to sit in contact with the seating surface, and the second position being suitable to receive installation of a removable child seat over the seat while disabling seating of a child on the seating surface, the backrest portion being configured to provide resting support for a child's back when the seat is in the first position, and the calf support portion being configured to provide support for the calves of a child when the seat is in the second position; and a locking mechanism operable to lock the seat in the first and second position.

27. The infant highchair according to embodiment 26, wherein the seat further has a mount surface suitable to receive installation of a removable child seat, the first position of the seat allowing a child to sit on the seat in contact with the seating surface, and the second position of the seat allowing installation of a removable child seat on the seat in contact with the mount surface.

28. The infant highchair according to embodiment 27, wherein the seating surface and the mount surface are located at two opposite sides of the seat, the seating surface facing upward in the first position, and the mount surface facing upward in the second position.

29. The infant highchair according to embodiment 26, 27 or 28, wherein the locking mechanism includes a latch that is assembled with the seat, the latch being engaged with the standing frame to lock the seat in the first and second position and disengaged from the standing frame to unlock the seat for rotation of the seat between the first and second position.

30. The infant highchair according to embodiment 29, wherein the locking mechanism further includes a spring connected with the latch, the spring applying a biasing action that urges the latch toward a locking state for locking engagement with the standing frame.

31. The infant highchair according to embodiment 29 or 30, wherein the standing

frame includes a bar segment, and the latch respectively engages with a first side of the bar segment to lock the seat in the first position and with a second side of the bar segment opposite to the first side to lock the seat in the second position.

32. The infant highchair according to embodiment 31, wherein the seat is pivotally  
5 connected about the bar segment.

**[0049]** Realizations of the infant highchair have been described in the context of particular embodiments. These embodiments are meant to be illustrative and not limiting. Many variations, modifications, additions, and improvements are possible. These and other variations, modifications, additions, and improvements may fall within  
10 the scope of the inventions as defined in the claims that follow.

**WHAT IS CLAIMED IS:**

1. An infant highchair comprising:  
a standing frame including a support platform;  
a seat pivotally connected with the standing frame and having a seating surface,  
5 the seat being rotatable between a first and a second position, the first  
position allowing a child to sit in contact with the seating surface, and the  
second position being suitable to receive installation of a removable child  
seat over the seat while disabling seating of a child on the seating surface,  
the seating surface moving around the support platform when the seat  
10 rotates relative to the standing frame, the second position of the seat  
uncovering the support platform so that a removable child seat is installable  
over the seat at least partially supported in contact with the support platform;  
and  
a locking mechanism operable to lock the seat in the first and second position.
- 15 2. The infant highchair according to claim 1, wherein the seating surface is located  
above the support platform in the first position and below the support platform in the  
second position.
3. The infant highchair according to claim 1 or 2, wherein the standing frame has a  
calf support portion fixedly connected with the support platform.
- 20 4. The infant highchair according to claim 1, 2 or 3, wherein the locking  
mechanism includes a latch that is assembled with the seat, the latch being engaged with  
the standing frame to lock the seat in the first and second position and disengaged from  
the standing frame to unlock the seat for rotation of the seat between the first and  
second position.
- 25 5. The infant highchair according to claim 4, wherein the standing frame includes a

bar segment, and the latch respectively engages with a first side of the bar segment to lock the seat in the first position and with a second side of the bar segment opposite to the first side to lock the seat in the second position.

6. The infant highchair according to claim 5, wherein the seat is pivotally  
5 connected about the bar segment.

7. The infant highchair according to claim 5 or 6, wherein the latch is pivotally  
connected with the seat, and the bar segment has a bending portion, the latch being  
rotatable relative to the seat between a locking state engaged with the bending portion  
for locking the seat in the first or second position, and an unlocking state disengaged  
10 from the bending portion for unlocking the seat.

8. The infant highchair according to any of claims 4 to 7, wherein the latch is  
pivotally connected with the seat about a pivot axis that extends substantially vertically  
when the infant highchair stands on a floor surface.

9. The infant highchair according to any of claims 4 to 8, wherein the locking  
15 mechanism further includes a spring and a release actuator respectively connected with  
the latch, the spring applying a biasing action that urges the latch toward a locking state  
for locking engagement with the standing frame, and the release actuator being operable  
to cause the latch to disengage from the standing frame for unlocking the seat.

10. The infant highchair according to claim 9, wherein the standing frame includes a  
20 first and a second cam surface, the first cam surface being adapted to contact and push  
the latch in movement against the biasing action of the spring as the seat approaches the  
first position for facilitating continued rotation of the seat to the first position, and the  
second cam surface being adapted to contact and push the latch in movement against the  
biasing action of the spring as the seat approaches the second position for facilitating  
25 continued rotation of the seat to the second position, the latch being disengaged from

the first cam surface when the seat reaches the first position and disengaged from the second cam surface when the seat reaches the second position.

11. The infant highchair according to claim 9 or 10, wherein the release actuator is disposed on a backrest portion of the seat and is connected with the latch via a cable.

5 12. The infant highchair according to any of claims 4 to 11, further including an impeding part assembled with the standing frame, and a second release actuator connected with the impeding part, the impeding part being configured to engage with the seat for forcing the seat to stop at an intermediate position during a rotation of the seat from the first position toward the second position while allowing continuous  
10 rotation of the seat from the second position past the intermediate position to the first position, and the second release actuator being operable to cause the impeding part to disengage from the seat in the intermediate position for rotation of the seat from the intermediate position to the second position.

13. The infant highchair according to claim 12, wherein the second release actuator  
15 is concealed when the seat is in the first position, and becomes exposed for operation when the seat is in the intermediate position.

14. The infant highchair according to claim 12 or 13, wherein the impeding part is pivotally connected with the standing frame, and the seat has a hook movable along with the seat, the hook coming into engagement with the impeding part to force the seat  
20 to stop in the intermediate position during a rotation of the seat from the first position toward the second position.