

April 18, 1939.

W. WISHINSKY

2,154,649

VEGETABLE AND FRUIT PRESS

Filed May 27, 1938

2 Sheets-Sheet 1

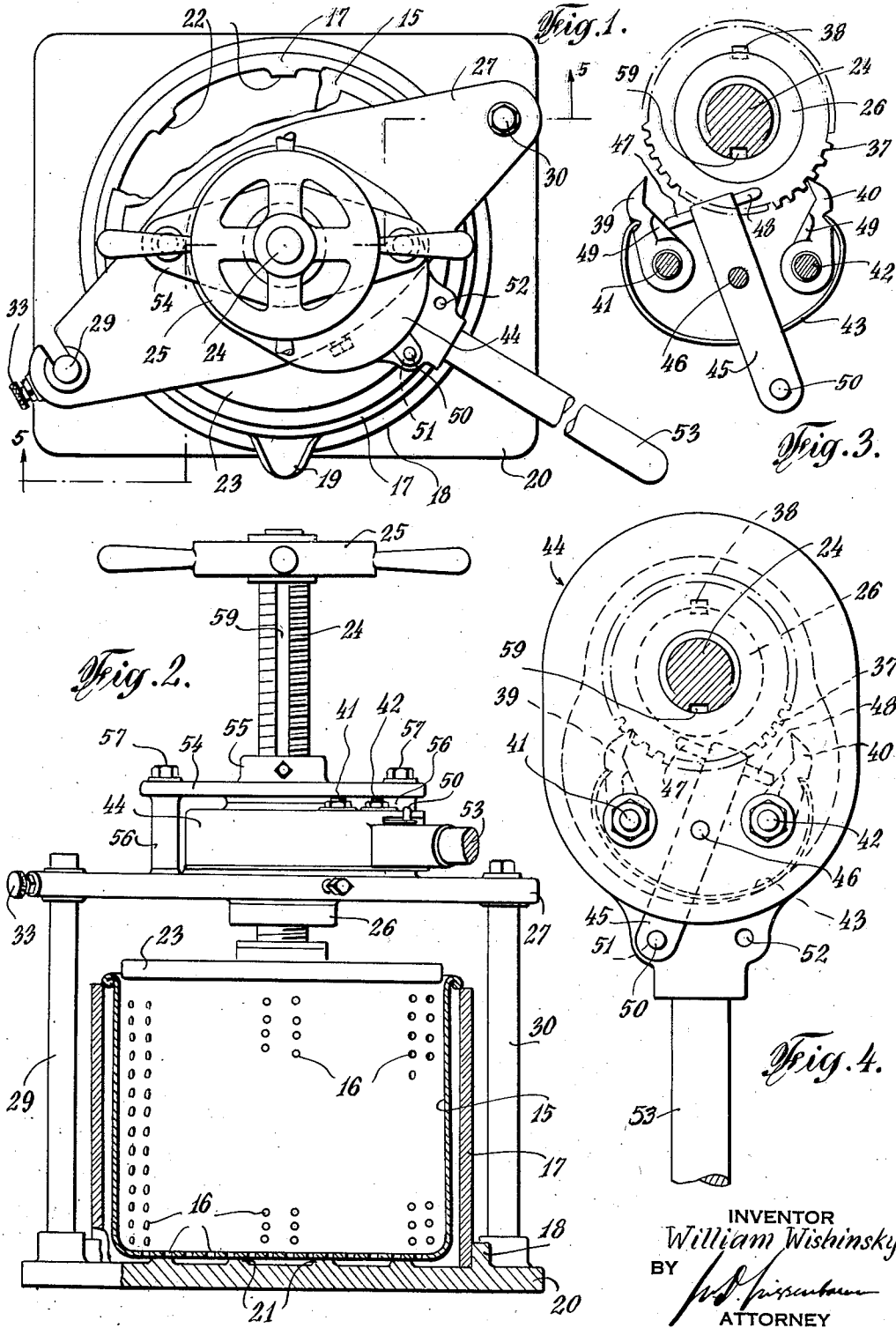

INVENTOR
William Wishinsky
BY *J. D. Pissinatti*
ATTORNEY

April 18, 1939.

W. WISHINSKY

2,154,649

VEGETABLE AND FRUIT PRESS

Filed May 27, 1938

2 Sheets-Sheet 2

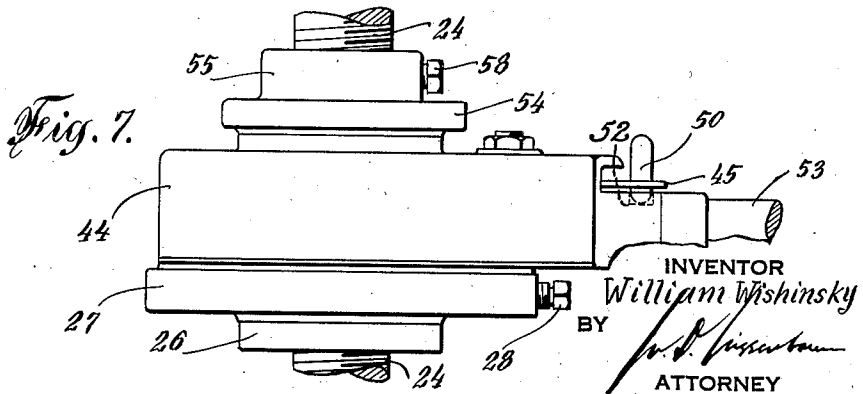
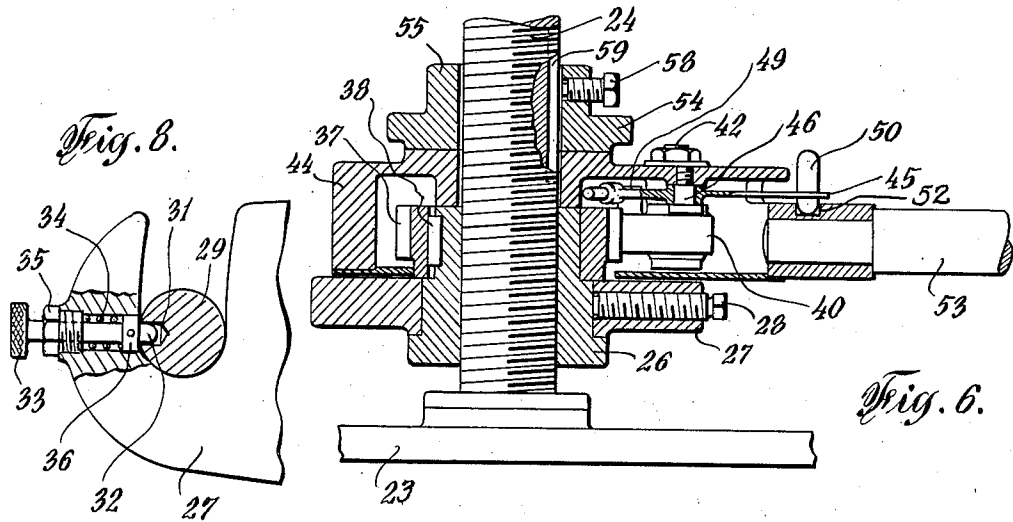
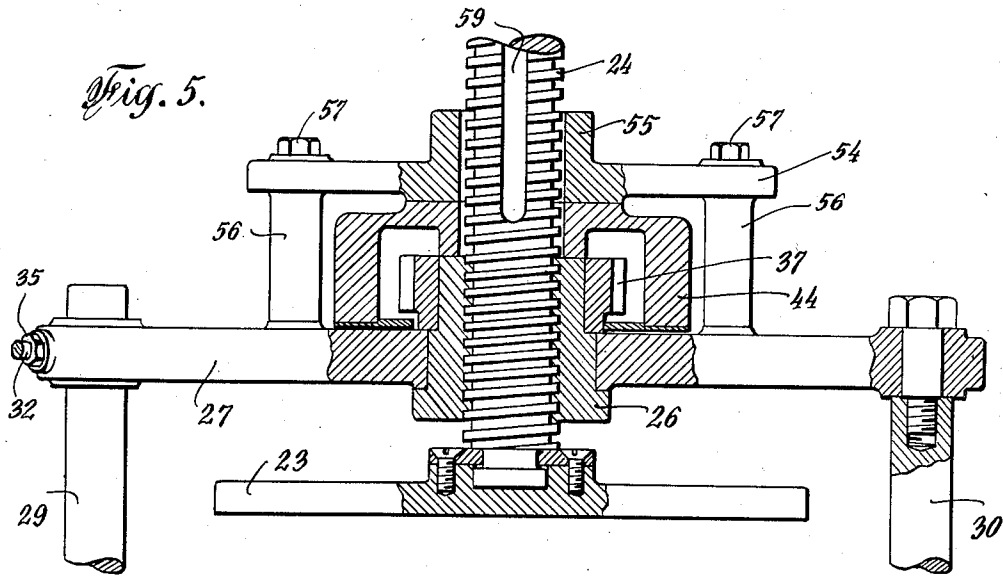

INVENTOR
William Wishinsky
BY *J. D. Wiseman*
ATTORNEY

UNITED STATES PATENT OFFICE

2,154,649

VEGETABLE AND FRUIT PRESS

William Wishinsky, New York, N. Y.

Application May 27, 1938, Serial No. 210,365

1 Claim. (Cl. 100—44)

My present invention relates to vegetable and fruit presses.

The principal object of this invention is to provide a press of novel and improved construction for extracting substantially all of the juices from fruit or vegetable mashes.

Other objects will become manifest as this disclosure proceeds.

In the accompanying drawings forming part of this application, similar characters of reference indicate corresponding parts in all the views.

Fig. 1 is a plan view of an embodiment of my present invention.

Fig. 2 is a front elevation of Fig. 1, partly in section.

Fig. 3 is an assembly, in plan, of screw actuating mechanism included in said embodiment, shown in one operative position.

Fig. 4 is a similar view of said mechanism encased, shown in another operative position.

Fig. 5 is an enlarged fragmentary section taken along lines 5—5 in Fig. 1.

Fig. 6 is a central longitudinal section through Fig. 7.

Fig. 7 is an enlargement of the main screw engagement structure included in Fig. 2.

Fig. 8 is an enlarged fragmentary sectional view showing the left end of Fig. 5 in plan.

In the drawings, 15 is a strainer receptacle having perforations 16. This receptacle which receives the mash to be pressed, sits within and is removable from cylinder 17, which at its base is demountably positioned within a ring 18 fashioned to include a forwardly extending spout 19 upon the base 20. Upwardly extending from this base, are the boss spacers 21, and the interior walls of the outer cylinder 17 have inwardly extending, spaced, longitudinal spacers 22. It is evident that liquid would flow out of the receptacle 15, through apertures 16, and finally discharge from the spout 19.

A platen 23 is journaled at the lower end of the main screw 24, while a wheel or other handle means 25 is secured at the top end of said screw. A flanged, internally threaded member 26, serves as a nut on the screw 24. This nut member is rotatably mounted through the frame piece 27 which latter is provided with a set-screw 28, for maintaining the nut member secure in the frame piece. Upwardly extending from the base 20, are a pair of vertical posts 29 and 30. The frame piece 27, at one end, is rotatably mounted at the upper end of post 30, for swinging movement in a horizontal plane. The other end of such frame piece, being fashioned as a hook, is provided with

a latch means comprising, pin 32 for engagement in socket 31 of post 29 and adapted to be withdrawn therefrom, by pulling the knob 33 against action of spring 34. Numeral 35 indicates a bushing through which pin 32 is slidably mounted and 36 is a collar fixed to said pin, for maintaining the assembly.

Up to this point, the operation of the press is ordinary. With nut member 26 held stationary by means of the said set-screw 28, the piston 27 is lowered or raised by turning the wheel 25. It is found that mash, after being pressed with such structure, still contains a substantial quantity of juice and it is quite impossible to lower the platen any further with the above described means. I therefore provide additional mechanism, so that at this phase of the operation, the movement of the piston could be continued downward until what remains in the receptacle 15, is a compressed, comparatively hard cake of solid matter.

To attain such, I provide a gear 37, which is positioned atop of the frame piece 27 and is carried on and secured to the flanged nut member 26 by means of a key 38. Within casing 44, housing said gear 37, are a pair of pawls 39 and 40, mounted on the spaced pins 41 and 42 respectively. A blade spring 43 acts to maintain the pawls in engagement with gear 37. A shifter arm 45 mounted on axis pin 46, is provided with the laterally extending shifter fingers 47 and 48. Each of the pawls has an integral upward extension 49, so that upon movement of the arm 45, about its axis 46, one of said fingers will shift the pawl it controls, out of engagement from the gear 37. One end of arm 45 extends outside the casing 44 and is provided with a set pin 50 including a downwardly extending portion for removable engagement in the sockets 51 and 52 in the top of the casing 44. Extending horizontally from said casing, is the handle 53. A hubbed plate 54 through which the main screw 24 passes clear, maintains the casing 44 atop the frame piece 27. Said main screw also passes clear through the ceiling of the casing. Bolts 57 engaging the frame piece 27, secure the plate 54 on the spacers 56. Through hub 55, is a set screw 58 for engagement with the main screw 24 along the latter's longitudinal keyway 59.

To continue with the operation after the platen 23 is lowered to such extent as hand turning of the wheel 25 will permit, the nut member 26 is loosened to revolve free, by slight withdrawal of the set-screw 28. The main screw 24, by back movement of the wheel 25, is turned until keyway 59 is in alignment with the set-screw 58, which

latter is then screwed into said keyway, whereby the main screw 24 is maintained against axial rotation.

5 Now shifter arm 45 is set to position as shown in Fig. 3, where pawl 39 engages gear 37, while
 10 finger 48 maintains pawl 40 out of such engagement. Upon oscillatory movement of handle 53, it is evident that nut member 26 will be given an
 15 intermittent movement about its axis, whereby the main screw 24 will correspondingly move downwards. The leverage present in the construction,
 20 will effect the greater force necessary to drive the screw to further compress the mash within receptacle 15. Operation by handle 53 is continued until the mash assumes a hard
 25 and substantially dry consistency. In fact, it becomes a hardened disc, to be discarded. At this time, the adhesion between the platen 23 and the compressed mash, is so tremendous, that
 30 restoration of the apparatus to its initial set-up for manual operation by handle 25 to raise the screw 24, is found impossible. I therefore take advantage of the existing leverage construction
 35 and make the setting shown in Fig. 4, by shifting the arm 45 so that shifter set is 50, resides in socket 52, at which time, pawl 40 by action of spring 43, will enter into engagement with gear 37, while finger 47 does shift pawl 39, and will maintain same out of engagement from said gear.
 40 Now upon movement of handle 53, the screw 24 will be caused to move upward. Only a small upward movement of the platen 23 is required to break the adhesion mentioned.

45 At this time the set-screw 58 is withdrawn from keyway 59, while set-screw 28 is screwed inward to secure the nut member 26 stationary with respect to the frame piece 27, and manual operation by hand wheel 25 can again be accomplished as originally. Piston 23 is raised until it clears the top of receptacle 15 whereupon withdrawal of the latch pin 32 from its engagement with post 29, will permit the entire structure carried on post 30 to be swung away to facilitate removal of receptacle 15. Members 27, 54 and 56 may be deemed a unitary frame structure. Also, the gear 37 with its associated nut member 26 may be deemed a unit.

This invention is capable of numerous forms and various applications without departing from the essential features herein disclosed. It is therefore intended and desired that the specific embodiments herein shown, be deemed illustrative and not restrictive and that the patent shall cover whatever features of patentable novelty exist herein; reference being had to the following claim, rather than to the specific description herein, to indicate the scope of this invention.

I claim:

In a press for extracting the juice of a mash, the combination with a receptacle to hold the mash, of a frame, a nut member journaled on the frame, a set-screw in threaded engagement with the frame, adapted to maintain the nut member against axial rotation, a screw in threaded engagement with the nut member, having a longitudinal keyway therein, a platen member at one end of the screw, adapted to press on the mash upon longitudinal movement of the screw into the receptacle, a handle means at the other end of the screw, a set-screw threadedly engaged in the frame adapted to be moved into said keyway to maintain the screw against axial rotation, a gear secured on the nut member coaxially therewith, a casing mounted loose about the screw, covering said gear, a pair of pawls within the casing and pivotally carried thereby, a spring means to maintain the pawls in engagement with the gear, a lever pivotally mounted on the casing and extending partially within and partially without said casing, a pair of shifter fingers extending from said lever and so positioned, that upon movement of said lever, one of the fingers will shift the pawl nearest to it, out of engagement from the gear, a handle extending from said casing and means to fix the position of said lever; said means including a pin on the lever and perforations in the handle, the pawls being so positioned, whereby they are adapted to drive the gear in opposite directions respectively.

WILLIAM WISHINSKY.