

(21) Application No 0018208.9
(22) Date of Filing 26.07.2000
(30) Priority Data
(31) 9917674 (32) 29.07.1999 (33) GB

(71) Applicant(s)
BG Intellectual Property Ltd
(Incorporated in the United Kingdom)
100 Thames Valley Park Drive, READING, RG6 1PT,
United Kingdom
(72) Inventor(s)
Andrew Sutherland
Haydn Parsonage
Peter Carson
(74) Agent and/or Address for Service
William Illingworth-Law
BG Intellectual Property Ltd, 100 Thames Valley
Park Drive, READING, RG6 1PT, United Kingdom

(51) INT CL⁷
F16L 55/164 55/18
(52) UK CL (Edition S)
F2P PTBL
U1S S1884
(56) Documents Cited
EP 0367400 A2 US 4626142 A
(58) Field of Search
UK CL (Edition R) F2G G41 , F2P PTBB PTBL PTBM
PTBX
INT CL⁷ F16L 41/04 41/06 55/10 55/164 55/18
Online: WPI,EPODOC,JAPIO

(54) Abstract Title
Pipe repair device and method

(57) A device for repairing a pipe includes an elongate insulated handle 10, which can have a number of different attachments connected to one of its ends. These attachments include a drill 25 to drill an aperture into the pipe and an injector head (31, figure 2) to inject sealant into the pipe from an above ground position. A tool 21 may also be attached to the handle 10 for excavating the ground to gain access to the pipe to be repaired. If the pipe is 'live', then a tapping adaptor (50-54, figure 4) may be attached to the end of the handle, and a nipple arrangement (63, figures 5 and 6) may be fitted to the tapped aperture, prior to the injection of the sealant. The handle 10 is preferable hollow, and has a compressed air inlet 14 and associated nipple 15. Preferably, a trigger device 16 controlled by handle 17 receives compressed air to power the various attachments.

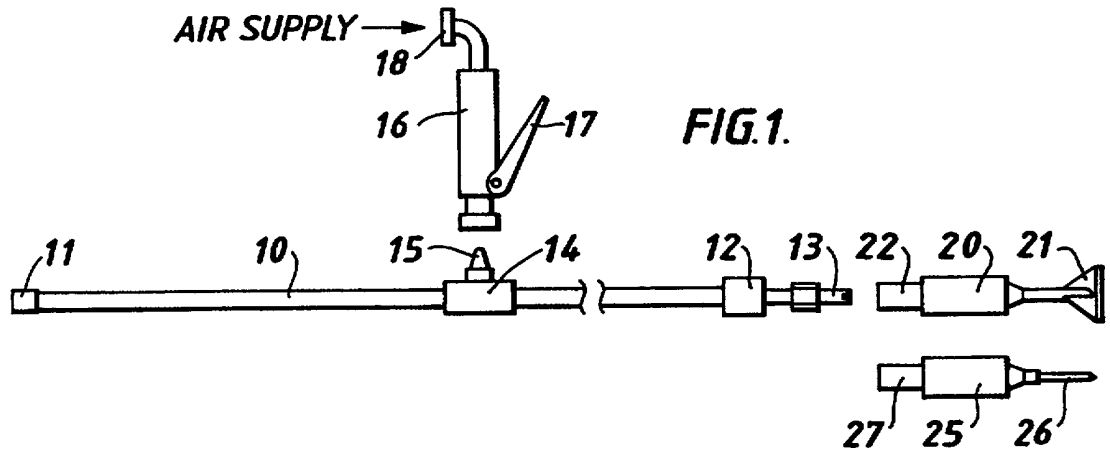

GB 2 352 791 A

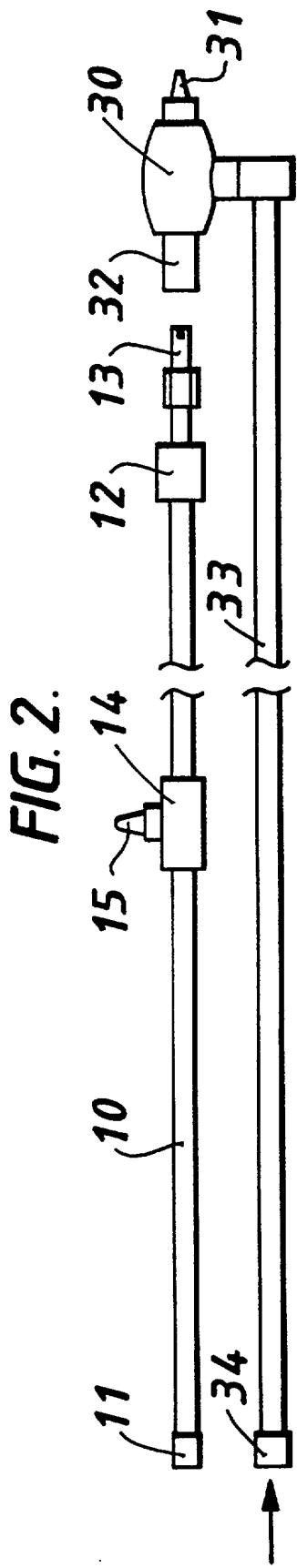
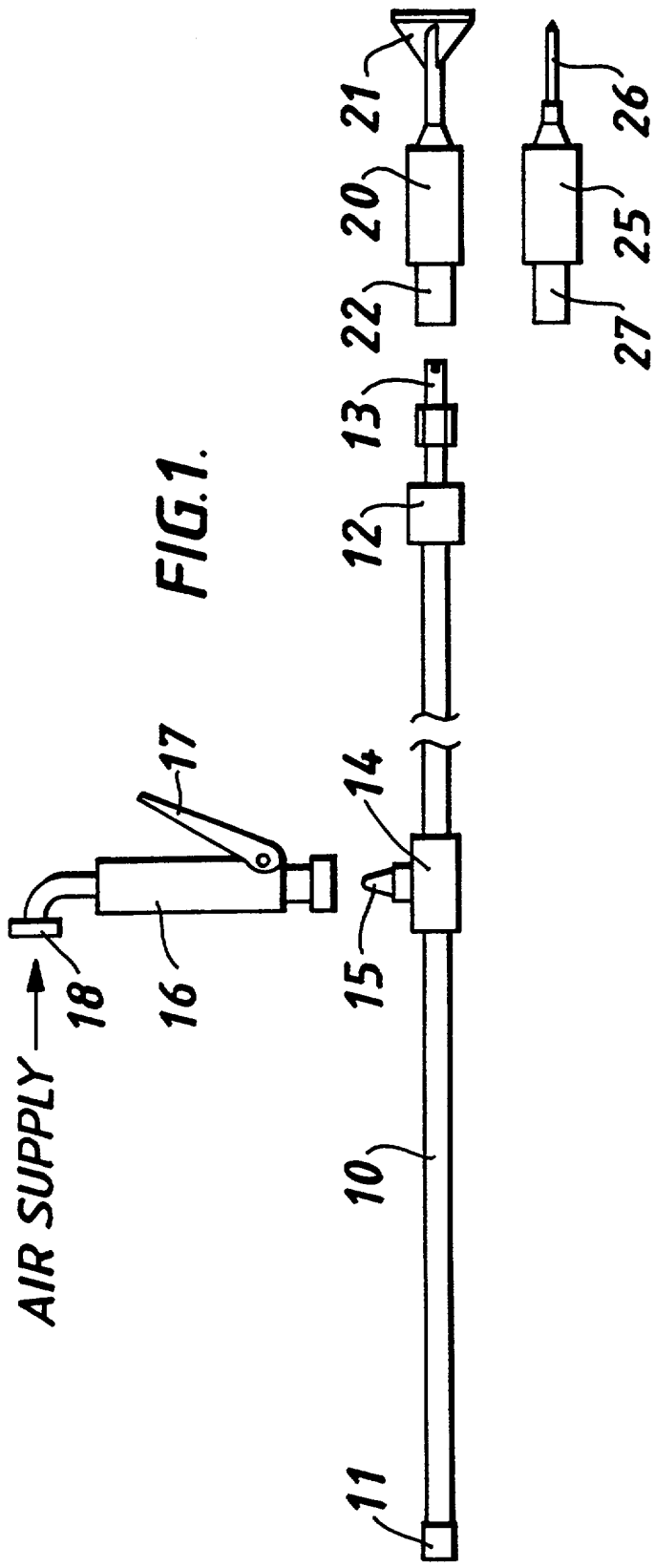

FIG. 3.

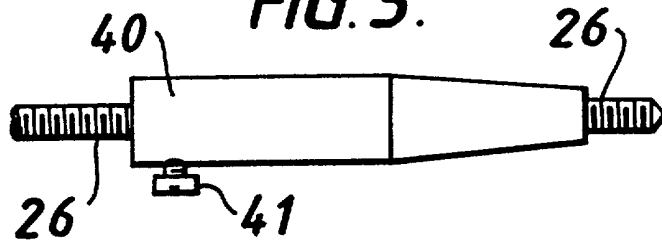

FIG. 4.

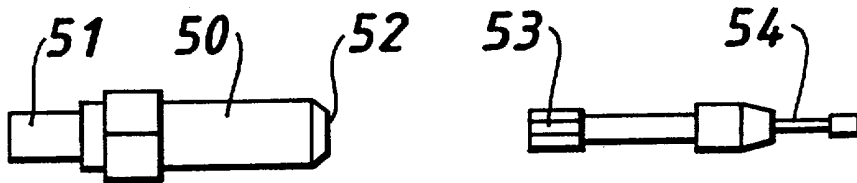

FIG. 5.

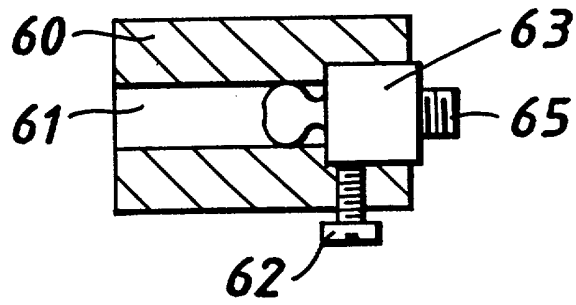
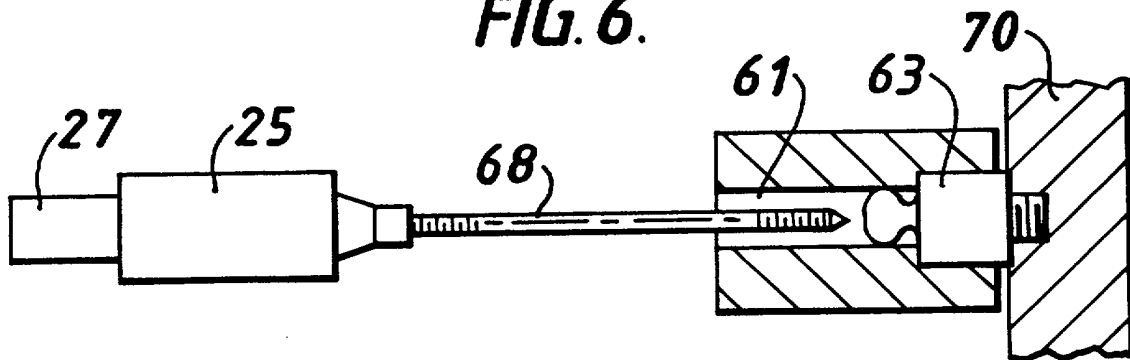

FIG. 6.



PIPE REPAIR DEVICE AND METHOD

The invention relates to pipe repair and more particularly to repairing existing buried pipes.

In the past to gain access to a gas main, for example, a large hole has to be dug to allow the operative to get down into the hole and then to use various methods to gain access to an aperture in the pipe that needs repairing or sealing.

Such arrangements require a large hole to be dug with the necessary side wall support to allow the operative safe access to the pipe so as to carry out a repair.

The present invention is concerned with a device and method which allows the operative to work above ground without the need to excavate large holes.

According to the invention there is provided a pipe repair device including

(a) an elongate insulated handle to allow operations to be carried out above ground,

(b) means for forming an aperture in the pipe attachable to the handle,

(c) means for fixing a fluid entry device to the pipe attachable to the handle, and

(d) means for injecting sealing fluid into the pipe via the entry device, said means for injecting sealing fluid being attachable to the handle.

Further according to the invention there is provided a method of repairing a fluid pipe including the steps of forming an aperture in the pipe from above ground by means of a device attached to an elongate insulated handle; fixing a fluid entry device to the pipe by means attached to the handle; and injecting sealing fluid into the pipe via the entry device by means attached to the handle.

The invention will now be described by way of example with reference to the accompanying drawings in which:

Figure 1 shows an elongate handle with associated air trigger and air motorised devices attachable thereto;

Figure 2 shows a fluid sealing device attachable to the handle;

Figure 3 shows a drill with a gauge to allow only partial drilling through the pipe;

Figure 4 shows attachments for allowing tapping of the hole to provide a thread;

Figure 5 shows an attachment with a nipple for insertion into the tapped hole; and

Figure 6 shows completion of the drilling through the nipple into the pipe interior.

The arrangement of Figure 1 includes an elongate rod-like handle 10 (e.g. two metres in length) of insulated material (e.g. fibreglass) to prevent electric shock which could otherwise occur if the ground contained buried cables adjacent the pipe to be partially excavated. The handle is hollow and is sealed at one end by cap 11 and terminates at the other end by adapter 12 which include an air connection attachment 13. Towards the other end of the handle 10, an air inlet 14 with associated nipple 15 is provided. To this inlet 14, an air supply trigger 16 operable by handle 17 is attachable. The hollow handle 10 and the air trigger 16 are operable at pressures typically of 110 psi. A source of compressed air (not shown) is connected to trigger 16 at coupling 18 to act as a power source for items attached to adapter 12 and air connection 13. Devices such as the air-knife 20 with blade 21 and the

drill head 25 with drill bit 26 can be attached and powered (e.g. at 1800 rpm) under the control of trigger 16.

To excavate the hole which may be as small as 1 ft (0.3 metres) in diameter to access the main, the air-knife 20 is attached to the handle 10 via coupling 22. Any earth is removed and any water vacuumed out so that access to the main is then available.

To effect a repair to the pipe, a small hole is drilled into the pipe to gain access to the pipe interior using air drill 25 head and drill 26 attached via coupling 27 to the elongate handle 10.

To repair the main in the region of the aperture produced by drill 26, the Figure 2 arrangement is utilised which includes sealant injection head 30 with injector nozzle 31. The head is connected to the elongate housing 10 via coupling 32. The head 30 includes an integral pump which is powered by the air supply under the control of trigger 16 (see Figure 1). A source (not shown) of sealant (e.g. anaerobic fluid) is connected to flow tube 33 via coupling 34 so as to be injected into the main to effect sealing on hardening.

In practice, rather than the pipe being empty when being

repaired, the main pipe may be carrying natural gas or other fluid, i.e. under 'live' conditions. In these circumstances it is necessary to include additional items in the repair kit and to carry out additional method steps to prevent gas escape during the drilling and sealing operations.

To inject fluid under these circumstances it is necessary to carry out the drilling operation in a number of steps as shown in relation to Figures 3 to 6.

The drilling operation described above is carried out only partially in the initial step by employing the depth gauge arrangement of Figure 3. Here the drill 26 is passed through the body of gauge 40 and set via screw 41 to extend beyond the end of the gauge by a set amount, dependent on the thickness of the pipe, to ensure that drilling will only cause an aperture to be formed in part of the pipe wall thickness (e.g. 10mm). This prevents any gas escape to the outside as part of the pipe wall is still between the aperture and the gas.

After this step has been carried out a tapping operation is effected using the Figure 4 arrangement.

An adaptor in the form of a quick release coupling

includes body portion 50 and square end adaptor 51 for slotting into the handle end in place of the drill head.

A tapping head includes body 53 for locating in adaptor end 52 which includes cutting tap 54 for producing an internal thread within the partial aperture drilled in the pipe.

During the tapping operation, with the air trigger 16 of Figure 1 removed, the air inlet 14 extending from the handle 10 at 90° can be manually grasped to assist in applying a turning torque to the tap when threading the pipe.

When tapping has been achieved, the tap is withdrawn and removed from the handle 10.

The next step requires the fitting of a nipple to the tapped aperture and is achieved using the Figure 5 arrangement. The coupling 50 of Figure 4 can be used again to which, in this case, the carrier 60 is coupled.

The carrier includes a bore 61 through the body and holds the nipple 63 by means of screw 62. The handle 10 is again rotated to effect screwing in of the nipple.

The threaded portion 65 of the nipple cannot extend into the pipe beyond the tapped portion.

Thereafter with the nipple 63 and carrier 60 still in place, the coupling 50 is removed and the drill head 25 is again fitted to elongate handle 10, as is the air trigger 16. A fine drill 68 is attached and the drill is operated through the bore 61 and the head of nipple 63 to penetrate the last remaining portion of the wall of pipe 70 to communicate with the gas in the bore of the pipe. Withdrawal of the drill 68 will not cause flow of gas externally, as the nipple forms a barrier to any gas flow.

The sealant can then be pumped into the pipe via the nipple using the arrangement described in Figure 2 above. The handle 10 can then be removed and the injector head left in place for (say) twenty minutes until the sealant has cured. The head can then be removed. The nipple can remain in place, with a suitable cover or cap if desired.

The arrangement using the above described kit provides a quick and safe method of sealing. The insulated handle 10 assists in this aim, being capable of withstanding internal pressure of more than 150 psi and electrical voltage of more than 100 KV.

CLAIMS:

1. A pipe repair device including
 - (a) an elongate insulated handle to allow operations to be carried out above ground,
 - (b) means for forming an aperture in the pipe attachable to the handle,
 - (c) means for fixing a fluid entry device to the pipe attachable to the handle, and
 - (d) means for injecting sealing fluid into the pipe via the entry device, said means for injecting sealing fluid being attachable to the handle.

2. A device as claimed in claim 1 including means attachable to the elongate handle for excavating the ground to gain access to the pipe to be repaired.

3. A device as claimed in claim 1 or 2 including means for completing the forming of the aperture in the pipe following fixation of the fluid entry device to the pipe.

4. A device as claimed in claim 3 including means for completing the aperture formation through an aperture present in the fluid entry device.

5. A device as claimed in any preceding claim including means attachable to the elongate handle for forming a thread within the aperture in the pipe to allow the fluid entry device to be affixed to the pipe.

6. A method of repairing a fluid pipe including the steps of

forming an aperture in the pipe from above ground by means of a device attached to an elongate insulated handle;

fixing a fluid entry device to the pipe by means attached to the handle; and

injecting sealing fluid into the pipe via the entry device by means attached to the handle.

7. A method as claimed in claim 6 including the step of completing the forming of the aperture in the pipe following the fixation of the fluid centring device step.

8. A method as claimed in claim 7 including the step of completing the aperture formation through an aperture present in the fluid entry device.

9. A method as claimed in any one of claims 6, 7 or 8 including the step of forming a thread within the aperture in the pipe to allow the fluid entry device to be affixed to the pipe.

10. A pipe repair device substantially as described herein with reference to the accompanying drawings.

11. A method of repairing a fluid pipe as claimed in claim 6 and substantially as described herein.



Application No: GB 0018208.9
Claims searched: 1-11

Examiner: Dr Steve Chadwell
Date of search: 9 August 2000

Patents Act 1977
Search Report under Section 17

Databases searched:

UK Patent Office collections, including GB, EP, WO & US patent specifications, in:

UK CI (Ed.R): F2G (G41); F2P (PTBB, PTBL, PTBM, PTBX)

Int CI (Ed.7): F16L 41/04, 41/06, 55/10, 55/164, 55/18

Other: Online: WPI, EPODOC, JAPIO

Documents considered to be relevant:

Category	Identity of document and relevant passage	Relevant to claims
A	EP 0367400 A2 (BRITISH GAS)	
A	US 4626142 (QUALI-TECH)	

X	Document indicating lack of novelty or inventive step	A	Document indicating technological background and/or state of the art.
Y	Document indicating lack of inventive step if combined with one or more other documents of same category.	P	Document published on or after the declared priority date but before the filing date of this invention.
&	Member of the same patent family	E	Patent document published on or after, but with priority date earlier than, the filing date of this application.