



US 20130344258A1

(19) **United States**

(12) **Patent Application Publication**
COVEY

(10) **Pub. No.: US 2013/0344258 A1**

(43) **Pub. Date: Dec. 26, 2013**

(54) **OPTICAL METHOD FOR ADDITIVE
MANUFACTURING OF COMPLEX
METALLIC SHAPES USING A GASEOUS
MEDIUM**

(52) **U.S. Cl.**
CPC **C23C 18/14** (2013.01)
USPC **427/586; 118/715**

(71) Applicant: **DEEP SPACE INDUSTRIES INC.,
MCLEAN, VA (US)**

(57) **ABSTRACT**

(72) Inventor: **STEPHEN DARRELL COVEY, ST.
AUGUSTINE, FL (US)**

(73) Assignee: **DEEP SPACE INDUSTRIES INC.,
MCLEAN, VA (US)**

(21) Appl. No.: **13/907,098**

(22) Filed: **May 31, 2013**

Related U.S. Application Data

(60) Provisional application No. 61/654,734, filed on Jun. 1, 2012.

Publication Classification

(51) **Int. Cl.**
C23C 18/14 (2006.01)

The present invention is a method for additive manufacturing in which a metal feedstock is converted to a carbonyl compound (or other gaseous media) and then optical heat patterns are used to direct the deposition of the contained metal into an arbitrary 3-D structure.

The optical methods used to guide the metal deposit may include one or more laser beams acting independently or in concert, and/or other optical technologies to apply a pattern of thermal energy, including LCD, LED, LCoS, DLP, or even CRT projection technologies.

The metals which may be deposited are limited to those which have compounds which are gaseous at moderate temperatures and which decompose (to a gas and the metal) upon the application of heat or specific chemical binding energies via optical means. Such compounds include (but are not limited to) nickel tetracarbonyl, iron pentacarbonyl, cobalt carbonyl, titanium iodide, and platinum chloro-carbonyl.

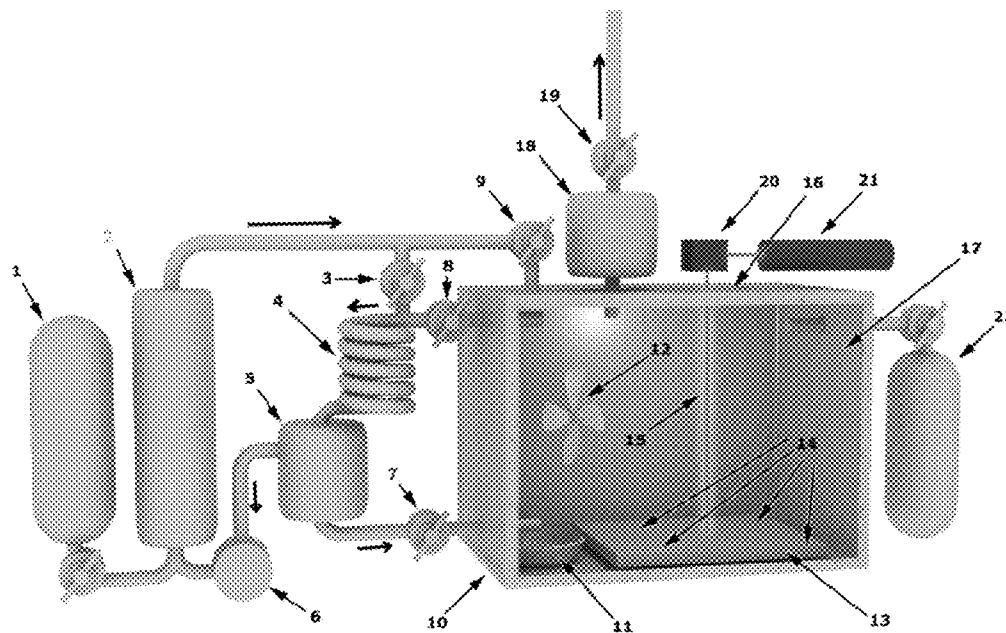
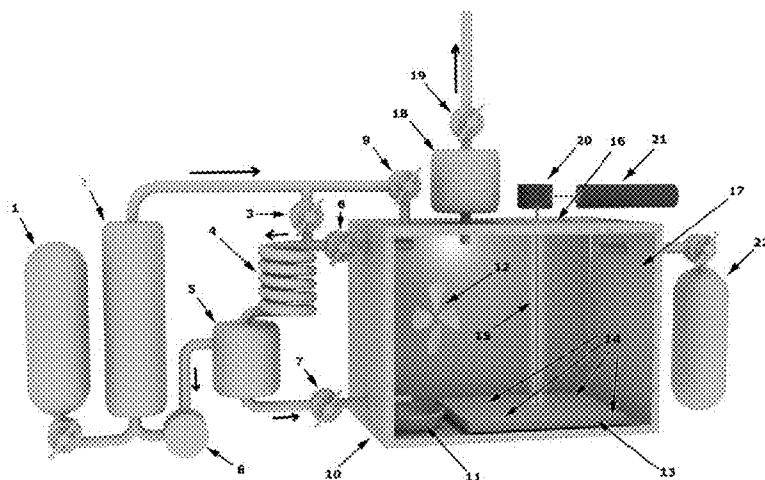

FIGURE 1



**OPTICAL METHOD FOR ADDITIVE
MANUFACTURING OF COMPLEX
METALLIC SHAPES USING A GASEOUS
MEDIUM**

BACKGROUND OF THE INVENTION

[0001] Traditional manufacturing methods are subtractive, meaning that a material or a group of materials must be removed until a desired product remains. Subtractive and traditional manufacturing and machining processes thus produce a significant amount of wasted material. More recently, additive manufacturing methods have become increasingly popular. In additive manufacturing, a material is deposited on a substrate to form a desired object. Additive manufacturing methods only deposit material needed to manufacture the product, and thus do not waste materials. Detailed computer assisted design (CAD) instructions can be input into additive manufacturing machines to create complex manufactured objects of very high complexity and quality.

[0002] It is therefore an object of the present invention to provide an additive manufacturing system and method that makes use of a common metal feedstock that can be converted to a carbonyl vapor (or other gaseous media) through a sublimation process. It is a further object of the present invention to deposit the metal from the carbonyl (or other) vapor according to an advanced CAD design process and then cool the substrate so that the metal vapor forms into the desired shape and structure.

BRIEF SUMMARY OF THE INVENTION

[0003] The Invention produces high density, high strength, high quality nickel (or other) metal parts. Some existing 3D metal printing technologies produce parts by laser sintering of metal powders, often using easily-melted coatings (solder) over stronger grains to avoid the necessity of completely melting the bulk metal, such as stainless steel powder. This process results in porous structures whose strength is limited by the soldering metal. Other existing 3D metal printing technologies extrude metal through a print head which melts it, essentially building up a product out of layers of melted metal. These products use low-melting-point, soft metals due to limitations of the printer heads, and thus can not be used to create high-strength, high-temperature-capable parts. The Invention uses a relatively low-temperature process wherein a gaseous medium containing the metal is heated via lasers or other optical patterning mechanisms to decompose the gas and deposit the metal at the heated point. The laser beam (in the preferred embodiment) is manipulated to transcribe a pattern of heat, the metal deposits into that pattern, and the pattern is changed with time such that a desired 3D product is produced from computer resident design specifications (3D Computer Aided Design).

BRIEF DESCRIPTION OF THE DRAWINGS

[0004] FIG. 1 represents a flow diagram of a process and apparatus depicting the invention.

DETAILED DESCRIPTION OF THE DRAWINGS

[0005] In order that the invention be better understood, a preferred embodiment will now be described (by way of example only) wherein FIG. 1 represents a flow diagram of a process and apparatus depicting the invention. The components described in FIG. 1 are:

- [0006] 1. A Carbon Monoxide supply tank (with valve and pressure regulator)
- [0007] 2. The Reaction Chamber, which contains a charge of nickel metal powder, a mechanism to resupply the nickel (not depicted), filters (not depicted) at the input and output to prevent the flow of powders out of the chamber, and a temperature control mechanism to heat the contents to specified temperatures.
- [0008] 3. A flow control valve left open during normal operation.
- [0009] 4. A condensing coil to convert warm metal carbonyl gas to a liquid.
- [0010] 5. A chamber to separate unreacted carbon monoxide gas from metal carbonyl liquid, collecting the liquid for subsequent use.
- [0011] 6. A pump to recycle carbon monoxide gas through the Reaction Chamber (2).
- [0012] 7. A valve to trickle metal carbonyl liquid into the Drip Pan (11) of the Deposit Chamber (10).
- [0013] 8. A valve, open during normal operation to recycle carbon monoxide gas from its production in the Deposit Chamber (10).
- [0014] 9. A valve, closed during normal operation, but open during safing operation.
- [0015] 10. The Deposit Chamber which is a temperature controlled pressure chamber, with an access door or panel (17), where the metal printing takes place.
- [0016] 11. A Drip Pan, which accepts the liquid metal carbonyl admitted via valve (7), and holds it as the liquid is vaporized.
- [0017] 12. A Recirculating Fan or Blower, which serves to distribute the metal carbonyl vapors throughout the Deposit Chamber, and also to provide a cooling flow to keep the substrates and previously deposited material below the metal carbonyl decomposition temperature.
- [0018] 13. A Printing Platform or plate, onto which the output product is 3D printed. It is composed of an unspecified material which conducts heat away from the deposit points while also being a non-stick material such that the output product may be easily removed.
- [0019] 14. The Print Area which is targetable by the laser beam(s) (or other optical heat patterning technology) and thus defines the maximum horizontal extents which may be printed. It may be as large as the entire Printing Platform (13).
- [0020] 15. The Laser Beam (or other optical) heat source which controls the pattern of metal deposit.
- [0021] 16. The Laser Window, which admits the Laser Beam (15) into the Deposit Chamber (10). It is composed of quartz or another material which is optically flat and transparent to the chosen laser wavelength.
- [0022] 17. The Access Door (or, as depicted, the Access Portal) which is a glass, quartz, or other material to monitor the progress of the 3D Printing Process. Note that it may be replaced via a solid door and interior camera in some embodiments.
- [0023] 18. The Neutralizing Chamber which converts potentially toxic gases such as carbon monoxide and metal carbonyl into harmless substances, implemented in this embodiment as a heated catalytic converter.
- [0024] 19. A valve and/or pressure regulator to dump output or waste gases to the exterior in a controlled fashion.

[0025] 20. A Laser Beam Controller, used to direct the X-Y position of the laser beam, as well as its focal depth. This controller converts the commands of a connected computer (not depicted) into beam position, and thus directs the 3D printing pattern.

[0026] 21. A Laser Beam (wavelength and technology chosen for efficiency and ease of use), generally several to several tens of watts of output power, which may be controlled by the connected computer (not depicted). When wavelengths and powers chosen are not eye-safe, the laser will have additional safety interlocks to prevent its operation except under controlled conditions.

[0027] 22. A tank of a neutral gas to flush the chambers of the apparatus during safing (or initializing) operations. It is equipped with a valve and pressure regulator.

NOT DEPICTED: temperature control mechanisms for the Reaction Chamber (2), Condensing Coil (4), Collection Chamber (5), Deposit Chamber (10), or Neutralizing Chamber (18); pressure and temperature sensors; laser beam safety shrouds around the beam exterior to the Deposit Chamber; the Laser Scanner which monitors the progress of the 3D printing; or the computer that converts a Computer Aided Design (CAD) document into commands for the laser and beam controller while monitoring chamber conditions.

DETAILED DESCRIPTIONS OF THE INVENTION

I. A General Explanation of the Invention and How to Practice It

[0028] The present invention is a new method for an additive manufacturing process of complex metallic shapes utilizing advanced computer assisted design. The process of the present invention deposits metal from a vapor in a precise 3d shape. Using a metal source feedstock, a unique laser (or other optical patterning method) to metal carbonyl (or other gas) vapor process allows for a new method of 3d printing. The metal deposition on a cold substrate is mediated directed by laser raster (or other optical) heating (or energy deposit) to build a free form object using a CAD design process to measure and observe the process.

[0029] The present invention seeks to create a unique additive manufacturing capability utilizing common metallic feedstock which is then sublimated by conversion to carbonyl gas and then subsequently deposited by using modifications of known 3d printing processes. By utilizing metal carbonyl vapor (or other gas) and an advanced multi-variable laser system driven by advanced CAD algorithmic software, the present invention allows for a new class of additive manufacturing machinery.

[0030] In addition, the low temperature of the metal additive process (well below the melting point) enables several additional capabilities:

[0031] 1) Other components and materials may be incorporated into output products, such as gaskets, bearings, insulators, or any other type of material that can withstand the modest (250 degrees C. or lower) temperatures,

[0032] 2) Metal parts may be welded together by using (for example) a laser to direct heat into a crevice or other gap, causing the deposition of metal in that gap to effect a weld. The relatively low temperature of the process enables dissimilar metals to be potentially welded, as the differing coefficient of thermal expansion will not be as much of an issue as with normal high-temperature (molten metal) welding.

[0033] In the preferred embodiment, the present invention comprises the following machinery components:

[0034] 1. A metal carbonyl (or other gas wherein the metal is chemically bound) production system

[0035] 2. A variable vapor delivery and pressure to provide active temperature control

[0036] 3. A substrate cooling system

[0037] 4. A laser rastering (multiple) An optical patterning and metal deposit sensor system

[0038] 5. A carbon monoxide (or other reagent)CO and vapor recovery mechanical system

[0039] Although the invention has been explained in relation to its preferred embodiment, it is to be understood that many other possible modifications and variations can be made without departing from the spirit and scope of the invention as herein described.

II. Detailed Description of the Apparatus and Operation

[0040] Note that the following description is an example of the process, described as to the specific active gas Nickel Tetracarbonyl Ni(CO)₄ and the 3D printing of nickel metal parts using a single laser. Alternative embodiments are described in the claims.

[0041] The process begins with the production of Ni(CO)₄ by circulating carbon monoxide (CO) gas from tank (1) through a source of warm (130° C.) nickel powder (in the Reaction Chamber (2)), which is condensed (4) at room temperature (25° C.) and collected as a liquid in the Collection Chamber (5). Then, the purified Ni(CO)₄ is piped through valve (7) into the warm Drip Pan (11) in the Deposit Chamber (10) where it evaporates and a laser beam (15) generates hot spots onto a substrate (13). The hot spots cause the Ni(CO)₄ to decompose into metallic nickel (which immediately deposits) and CO gas. The CO gas/Ni(CO)₄ gas mixture is recycled through the Collection Chamber (5) via open valve (8) which serves to condense and regenerate the Ni(CO)₄ by circulating the CO through the Reaction Chamber (2).

[0042] The operational process is as follows:

[0043] Setup (initial cleansing)

[0044] Close exhaust valve (19) only and pump down to vacuum

[0045] OR open all valves and flush with nitrogen from tank (22) with CO pump (6) running

[0046] Fill chambers with CO (Carbon Monoxide) from tank (1)

[0047] Generate Ni(CO)₄

[0048] Enable heaters bringing Reaction Chamber (2) to 150° C., Deposit Chamber (10) to 50° C., and Neutralizing Chamber (18) to 350° C.

[0049] Operate CO Pump (6) with valve (3) open and valves 7, 8, 9, and 19 closed.

[0050] Add CO as required to maintain target pressure (automatic via regulator valve on tank 1)

[0051] Stop when desired volume of liquid Ni(CO)₄ accumulates

[0052] Operate

[0053] Open drip valve 7 to deliver liquid Ni(CO)₄ into drip pan 11 in Deposit Chamber (10). Open valve 8, and set pressure regulator/valve 19 to exhaust gases in case of overpressure condition. Turn on blower (12).

[0054] Use computer (not depicted) to convert 3D schematic into control signals for the Laser (21) and

beam controller (20) to transcribe desired pattern onto substrate 13 while monitoring temperatures and pressures of chambers, substrate plate, and laser-heated spots if possible. Separate Laser Scanner (not depicted) is used to monitor progress to insure correct depth of metal deposit.

[0055] Byproduct CO gas, passing into the recirculating Reaction Chamber circuit, will regenerate Ni(CO)₄ in Reaction Chamber (2) as replacement pure liquid Ni(CO)₄ will drip into the Deposit Chamber.

[0056] Stop when sample part is complete

[0057] Open Deposition Chamber

[0058] Close drip valve (7) and valve 3, open valve 9 and allow liquid Ni(CO)₄ to accumulate in Collection Chamber (5) until most Ni(CO)₄ has been collected.

[0059] Close all valves and evacuate reaction chamber using vacuum pump (not depicted), then fill with nitrogen gas

[0060] OR close all valves except exhaust valve 19 which is set to "full open" (no pressure regulation), then flush with nitrogen gas to pass remaining gases through Neutralizing Chamber 18.

[0061] Open Deposition Chamber Door (17) and remove part

[0062] Neutralize (used to "safe" the apparatus for transportation or storage)

[0063] Set Reaction Chamber (2) to 250° C. and Collection Chamber (5) to 50° C. (which will vaporize any remaining Ni(CO)₄), operate CO Pump (6) until all Ni(CO)₄ has decomposed into nickel powder in Reaction Chamber (2), then evacuate or flush CO with nitrogen through Neutralizing Chamber (18).

1. A system of directing the deposit of metal into a 3D structure from a gaseous chemical compound containing a bound metal using optically directed energy.

2. A method of (1) wherein a laser is used via a beam control mechanism to apply energy in a direct pattern.

3. A method of (2) where the laser is used to apply thermal energy to decompose the gas medium and deposit metal.

4. A method of (2) where the laser is used to apply chemical energy of a specific level to excite or decompose the gas medium to deposit metal.

5. A method of (2) where the laser energy is deposited via a raster scanning method.

6. A method of (1) where multiple lasers are simultaneously used to deposit metal at multiple locations.

7. A method of (1) where multiple lasers beams intersect to apply incremental energy such that metal is only deposited where the laser beams intersect.

8. A method of (1) where an optical imaging system (such as a CRT, LCD, DLP, or LCoS projector) is used to direct the pattern of heating and thus metal deposition.

9. A method of (1) where the gaseous chemical compound is a metal carbonyl.

10. A method of (1) where the gaseous chemical compound is nickel tetracarbonyl.

11. A method of (1) where the gaseous chemical compound is iron pentacarbonyl.

12. A method of (1) where the gaseous chemical compound is dicobalt octacarbonyl.

13. A method of (1) where the gaseous chemical compound is titanium iodide.

14. A method of (1) where the gaseous chemical compound is a metal halide.

15. A method of (1) where the metal deposit rate is limited by the cooling of the substrate to below the decomposition temperature via conduction through the substrate.

16. A method of (1) where the metal deposit rate is limited by the cooling of the substrate to below the decomposition temperature via convective cooling using a fan, blower, or other method to cause the gaseous medium to flow past the metal deposit points.

17. A method of (1) where the byproducts of metal deposition are continuously recycled into replacement metal gas compound(s).

18. A method of (9) where the carbon monoxide produced by the decomposition of the metal carbonyl is continuously recycled into fresh metal carbonyl.

19. A system of directing the deposit of metal from a gaseous chemical compound containing a bound metal using optically directed energy around non-metallic or dissimilar metal parts, incorporating these into the metal product.

20. A system of directing the deposit of metal (a weld) into a gap between two parts to be joined or into a fracture or crack of a part to be repaired from a gaseous chemical compound containing a bound metal using optically directed energy.

* * * * *