

600507

FORM 1
REGULATION 9

COMMONWEALTH OF AUSTRALIA

PATENTS ACT 1952-1973

APPLICATION FOR A PATENT

I/We K.I.D. DESIGN GROUP LIMITED

of Unit 1, 65-67 Hagden Lane, Watford, Hertfordshire WD1 8NA, GREAT
BRITAIN

hereby apply for the grant of a Patent for an invention entitled:

CHILD-PROOF SAFETY GATE

which is described in the accompanying complete specification. This
Application is a Convention Application and is based on the Application(s)
numbered: 8620207 for a Patent or similar protection made in United Kingdom
on 20 August 1986.

My/Our address for service is:

GRIFFITH HASSEL & FRAZER
71 YORK STREET
SYDNEY N.S.W. 2000
AUSTRALIA

APPLICATION ACCEPTED AND AMENDMENTS

ALLOWED 8.6.90

DATED this 19th day of August, 1987.

K.I.D. DESIGN GROUP LIMITED

By his/their Patent Attorneys

John Terry

GRIFFITH HASSEL & FRAZER

LODGED AT SUB-OFFICE

19 AUG 1987

Sydney

TO: THE COMMISSIONER OF PATENTS
COMMONWEALTH OF AUSTRALIA

1317A:rk

AUSTRALIA

Patents Act 1952

DECLARATION IN SUPPORT OF A CONVENTION OR NON-CONVENTION
APPLICATION FOR A PATENT OR PATENT OF ADDITION

Name(s) of Applicant(s)
Title
Name(s) and address(es) of person(s) making declaration

In support of the application made by K.I.D. DESIGN GROUP LIMITED
for a patent for an invention entitled CHILD-PROOF SAFETY GATE

I/~~We~~, David DE ROZARIEUX, of: C/o Kiddi-Proof Products Ltd., Unit 1, 65-67 Hagden Lane, Watford, Hertfordshire, WD1 8NA, Great Britain

do solemnly and sincerely declare as follows:-

1. I ~~am/we are~~ the applicant/s for the patent, or am/~~we~~ authorised by the abovementioned applicant to make this declaration on its behalf.
2. The basic application(s) as defined by Section 141 of the Act was/~~were~~ made in the following country or countries on the following date(s) by the following applicant(s) namely:-

in	<u>Great Britain</u>	on	<u>20 August</u>	<u>1986</u>
by	<u>K.I.D. DESIGN GROUP LIMITED</u>			
in		on	<u>19</u>	
by				
3. The said basic application(s) was/~~were~~ the first application(s) made in a Convention country in respect of the invention the subject of the application.
4. The actual inventor(s) of the said invention is/~~are~~ David DE ROZARIEUX of C/o Kiddi-Proof Products Ltd., Unit 1, 65-67 Hagden Lane, Watford, Hertfordshire, WD1 8NA, Great Britain.
5. The facts upon which the applicant(s) is/~~are~~ entitled to make this application are as follows:-
By virtue of the position of the inventor as Managing Director of the Applicant

Country, filing date and name of Applicant(s) for the or each basic application

Name(s) and address(es) of the or each actual inventor
See reverse side of this form for guidance in completing this part

DECLARED at Watford this 20th day of August 1987

K.I.D. DESIGN GROUP LIMITED

By [Signature]

This form may be completed and filed after the filing of a patent application but the form must not be signed until after it has been completely filled in as indicated by the marginal notes. The place and date of signing must be filled in. Company stamps or seals should not be used.
No legalisation is necessary

(11) AU-B-77213/87
(10) 600507

-2-

in use such that on release of the wicket from the first wing, the wicket tends to swing open about the hinge under its own weight.

600507

COMMONWEALTH OF AUSTRALIA

PATENTS ACT 1952

Form 10

SUBSTITUTE COMPLETE SPECIFICATION

FOR OFFICE USE

Short Title:

Int. Cl:

Application Number:
Lodged:

Complete Specification—Lodged:
Accepted:
Lapsed:
Published:

Priority:

Related Art:

This document contains the amendments made under Section 49 and is correct for printing.

TO BE COMPLETED BY APPLICANT

Name of Applicant: K.I.D. DESIGN GROUP LIMITED
Address of Applicant: Unit 1, 65-67 Hagden Lane, Watford,
HERTFORDSHIRE WD1 8NA, GREAT BRITAIN
Actual Inventor: David De Rozarieux
Address for Service: GRIFFITH HASSEL & FRAZER
71 YORK STREET
SYDNEY NSW 2000
AUSTRALIA

Complete Specification for the invention entitled:

CHILD-PROOF SAFETY GATE

The following statement is a full description of this invention, including the best method of performing it known to me/us:-

2236A:rk

CHILD-PROOF SAFETY GATE

This invention relates to a child-proof safety gate, and more particularly to a child-proof safety gate which may be temporarily fitted in doorways, across passages or stairways or at other thresholds, to prevent access by infants whilst allowing adults to pass through.

One known gate of this type is described in U.K. 1571070. The gate comprises a stationary U-shaped frame whose two upright limbs are provided on their vertical outer edges with horizontally-adjustable anchors for frictional engagement with the side walls of the threshold. By tightening the anchors, the stationary frame is horizontally compressed, and the frictional engagement of the anchors with the door-frame clamps the safety gate in place even when subjected to an externally-applied force. A rectangular wicket is hinged to the vertical inner edge of one of the limbs, and is releasably latchable to the other limb. This allows the wicket to be swung to one side allowing adults to pass through the gate without having to unclamp the frame.

One problem with such a gate is that, unless the gap

for the wicket between the two limbs is quite narrow, the stationary frame is distorted by the horizontal compression forces at its top, causing the wicket to become trapped. If the wicket is narrowed in an attempt to avoid this problem, then the gap remaining after opening the wicket is too narrow for an adult to pass easily through.

Another problem which is experienced with such a gate is that the wicket tends to swing rapidly back to the closed position if it collides with a wall or a stop whilst being opened. This can be dangerous, particularly if an adult is passing through the gate with an infant.

A further problem with this type of gate, is that if it is unlatched, a child can swing back and forth on the open wicket damaging it, or falling off and injuring himself.

According to one aspect, the present invention provides a child-proof safety gate for a doorway or other threshold, comprising a frame which comprises a base having two wings extending substantially vertically from opposing ends thereof, each of said wings including means for releasably clamping the frame across the threshold, and a wicket having a shape which is substantially

complementary to the shape of the frame, the wicket being releasably secured to a first of the wings and hinged to the other, the hinge axis being inclined to the vertical in use such that on release of the wicket from the first wing, the wicket tends to swing open about the hinge under its own weight.

According to a second aspect, the invention provides a child-proof safety gate for a doorway or other threshold comprising:

a frame which comprises a base having two wings extending substantially vertically from opposing ends thereof, each of said wings including means for releasably clamping the frame across the threshold, and

a wicket having a shape which is substantially complementary to the shape of the frame, the wicket being releasably secured to a first of the wings and being secured to the other by at least one hinge,

raising of the wicket causing it to be released from the first wing, the hinge being arranged to permit such raising, the hinge being associated with a spring whose bias acts against the raising of the wicket.

The wicket of the invention is thus biased gravitationally to the open position, whereby the problem of the

wicket rebounding to the closed position is avoided. This is particularly so if the gate is arranged so that a lower corner of the wicket engages the ground when it is fully opened.

The gate according to this invention also overcomes the previous problem encountered of children swinging back and forth on the wicket. This is because the wicket of the present gate is only able to swing freely to the open position, and cannot freely swing back to the closed position.

In a preferred embodiment of the invention, the inclination of the hinge axis has the advantage that it allows the gap between the wings, into which the wicket fits, to widen upwardly. It has been found that by providing at least one, and preferably both, of the wings with inner edges which are inclined upwardly and outwardly, and in this way providing such an upwardly widening gap, the stationary frame has a greater resistance to the horizontal compression forces which it may be subjected to when secured in position.

The increased width of the wicket's upper region also has the effect of allowing adults to pass more easily through the gate when the wicket is in its open position.

Preferably, the wicket is generally trapezoidal in shape having upper and lower edges which are generally straight and parallel.

The wings preferably have right-angled lower, outer corners, and are preferably generally triangular.

In order to allow the gate to be fitted to thresholds of widely differing widths, one or more lateral extension frames may be provided for attachment to one or both wings.

The base preferably extends the full width of the stationary frame, and is preferably connected to the bottom edge of each wing so that the wicket is suspended above the underside of the base to provide a vertical clearance, when the wicket is closed, between the undersides of the wicket and of the base. The vertical clearance is preferably such, in relation to the angle of inclination of the hinge axis and the size of the wicket, that the wicket may be opened at least a quarter-turn to a fully open position at which the said vertical clearance is zero. In use, with the base resting on flat ground, the wicket would engage the ground at this fully open position.

The wicket is preferably releasably secured in its closed position by a catch on the wing opposite the wing to which it is hinged. The catch is preferably releasable only by first raising the wicket, and the hinge is designed to allow the wicket to have a limited degree of vertical movement.

The catch is preferably provided with a releasable safety latch for preventing the raising of the wicket. The safety latch is preferably biased to its locked position in which it prevents the wicket being raised, so that the wicket can only be opened by releasing the safety latch and simultaneously raising the wicket.

The outer edge of one, and preferably both, of the wings is preferably provided with at least one horizontally adjustable anchor for frictional engagement with the vertical sides of the threshold to clamp the safety gate in place. The horizontal adjustment of the anchor or anchors places the stationary frame under compression, giving rise to friction between the anchor or anchors and the side or sides of the threshold, sufficient to resist externally-applied forces on the safety gate. Preferably, two such anchors are provided at vertically-spaced positions on the or each outer edge.

In the drawings:

Figure 1 is a front elevation of a safety gate according to one embodiment of the invention fitted across a doorframe;

Figure 2 is a side elevation, on an enlarged scale, of a catch of the safety gate of Figure 1;

Figure 3 is a side elevation, on an enlarged scale, of a hinge of the safety gate of Figure 1; and

Figure 4 is a perspective view of a safety gate according to a second embodiment of the invention.

Turning to Figure 1, this illustrates a safety gate 10 constructed in accordance with a first embodiment of the invention. The gate 10 is generally symmetrical about a central vertical axis, and comprises two wings 12,13 interconnected by a base 14 extending horizontally across the full width of the safety gate. A wicket 11, trapezoidal in shape with parallel, horizontal top and bottom edges, is hinged at one of its side edges to an inner edge of the right-hand wing 13. The wings 12,13 are generally triangular, with right-angled lower, outer corners, and the wicket 11 and wings 12,13 are coplanar and complementary in shape in their common plane.

The safety gate 10 has two vertically-spaced, horizontally-adjustable anchors 18 at the outer edge of each wing 12,13 for frictional engagement with vertical sides of a doorframe F. Each anchor 18 comprises a bolt 20 in screw-threaded engagement with a horizontal bore through the corresponding outer edge of the wing. The inner end of the bolt 20 is connected to a knob 21, and the outer end is connected to a friction block 19. The horizontal position of the friction block 19 is adjustable, relative to the stationary frame, by turning the bolt using the knob 21. Appropriate adjustment of the anchors 18 places the stationary frame 12,13,14 under compression, giving rise to frictional forces at the blocks 19 sufficient to clamp the safety gate in position and to resist being moved by any externally-applied force on the safety gate.

Each wing 12,13 comprises of a hollow, rectangular-section tube of inverted 'V' shape, having vertical and inclined limbs joined by a curved section. The lower ends of the limbs are fixed to the base 14. Each wing further comprises vertical guard bars 22,23 whose lower ends are fixed to the base 14, for preventing access by infants.

The wicket 11 comprises a closed, trapezoidal frame of hollow, rectangular-section tube, similar to that

forming the edges of the wings 12,13, and has five guard bars 24 extending between its upper and lower edges in a fan shape, to prevent access by infants. The wicket is suspended by a pair of identical hinges 15 spaced along a hinge axis parallel to, and closely adjacent, an edge of the wicket 11. The hinge axis is inclined to the vertical by an acute angle which is in the range of 15° - 40° , preferably about 30° .

As shown in Figure 3, each hinge 15 comprises a pintle 151 fixed to the inner edge of the wing 13 by a bracket, and an open-ended socket 152 fixed to the edge of the wicket by a bracket. The pintle 151 extends through the socket 152 and has a burred upper end to retain the pintle in the socket. A limited degree of vertical movement (arrows 27 and 25, in Figures 3 and Figure 1 respectively) is allowed, to enable the wicket 11 to be raised for opening, as described below.

A vertical clearance is provided by the base 14, between the undersides of the wicket 11 and of the base 14. In use, with the base resting on flat ground (as shown in Figure 1), the wicket may be opened under gravity through an angle of at least a quarter-turn to a fully open position at which the lower, outer corner of

the wicket engages the ground, and remains gravitationally biased to that open position. The angle of inclination of the hinge axis and the vertical clearance under the wicket are, of course, selectable to provide any predetermined maximum angle of opening of the wicket.

The wicket is releasably held at its closed position, as shown in Figure 1, by two catches 16,17 spaced vertically along the edge of the wicket opposite the hinges 15, and along the corresponding inner edge of the wing 12. As shown in Figures 1 and 2, latch pins 161,171 project horizontally from the wicket 11 to other portions of the catches which are fixed to the wing 12. Each catch 16,17 has a U-shaped bracket 162 which receives the corresponding latch pin 161,171 through an upper opening and which then prevents horizontal movement of the pin 161,171. The upper catch 16 also has a hook-shaped latch 163 which pivots (arrow 26) about the U-shaped bracket 162 to lock the pin in the bracket 162.

The lower catch 17 acts as a stay, and has no locking latch 163. In use, the wicket is held closed by both catches 16,17, and may be opened only by pivoting and holding the locking latch 163 away from engagement with the pin 161 of the upper catch 16, simultaneously raising (arrow 25) the wicket 11 on its hinges to lift

the pins 161,171 clear of the U-shaped brackets 162, and then allowing the wicket to turn about its hinges under gravity. The deliberate complexity of this opening operation is sufficient to prevent infants from opening the wicket.

In order to accommodate a wide range of widths of doorframe F, or other types of threshold, a lateral extension (not shown) may be fitted to one or both wings. This could consist of a rectangular frame with two anchors 18 on its vertical side edge, the opposite side edge being connectable to the outer edge of the corresponding wing by removing the anchors 18 thereon and fitting connecting bolts in their place.

The principal elements of the safety gate are preferably made of steel coated with plastics material.

Turning now to Figure 4, this illustrates a safety gate 20 constructed in accordance with a second embodiment of the invention. The majority of its components correspond to those present in the first embodiment illustrated in Figure 1, and have been given the same reference numerals. These components have been fully described in the foregoing description, and are therefore not described further.

The wings 12,13 and base 14 have sockets 38,39 respectively into which anchoring means 50 is fitted. Each anchoring means 50 comprises a housing 51 which is fitted into each of the sockets 38,39. The housing has a bore into which a bolt 53 may be screw threaded. A friction block 54 is positioned on the outer end of the bolt for engaging the side of the threshold.

The bolt has a knob 52 attached to it, rotation of which causes the bolt to move in and out of the housing 51. This enables each friction block 54 to be independently adjusted to allow the gate to be clamped to thresholds of varying sizes as previously described.

The gate further comprises latching means 70 which releasably secures one side of the wicket to the wing 12. The latching means 70 is located towards the top of the gate to prevent it being reached and tampered with by small children. The latch comprises a tongue 72 connected to the wicket 11 which when the wicket is in its closed position, nests in a slot formed between the wing 12 and a bracket 71 fastened at its lower end to the wing.

The gate 10 is opened by raising the wicket and the

attached tongue 72 clear of the bracket 71, and then allowing the wicket to turn about the hinges 60 under the influence of gravity.

Hinges 60 are provided to connect the other side of the wicket 11 to the wing 13. Each hinge 60 includes a hinge member 62 which rotates around a pintle (unshown). A spring 61 is also provided around each pintle above the hinge member. This arrangement allows an adult to raise the wicket 11 against the biasing force of the springs whereby the wicket may be opened. However, small children are unable to open the wicket due to the biasing force provided by the springs 61. The springs 61 may be surrounded by a collar to prevent children catching their fingers in them.

Although the invention has been illustrated by the particular examples shown in the drawings, various modifications are envisaged, still within the scope of the invention. For example, although the method of opening and closing the wicket, using the particular hinges and catches shown and described above, is considered most advantageous, a more conventional latch could be used without the need for vertical movement of the wicket. Further, although the configuration of the wicket and wings provides a gap, for access with the wicket open, which widens upwardly, and gives rise to a particularly good resistance to horizontal compression forces, other configurations are possible, still allowing the hinge axis to be inclined.

~~CLAIMS:~~

THE CLAIMS DEFINING THE INVENTION ARE AS FOLLOWS:

1. A child-proof safety gate for a doorway or other threshold, comprising:

a frame which comprises a base having two wings extending substantially vertically from opposing ends thereof, each of said wings including means for releasably clamping the frame across the threshold, and

a wicket having a shape which is substantially complementary to the shape of the frame, the wicket being releasably secured to a first of the wings and hinged to the other, the hinge axis being inclined to the vertical in use such that on release of the wicket from the first wing, the wicket tends to swing open about the hinge under its own weight.

2. A safety gate according to Claim 1, wherein the gap for the wicket between the wings widens upwardly from the base.

3. A safety gate according to Claim 1 or Claim 2, wherein the wicket is generally trapezoidal, its upper

and lower edges being substantially straight and parallel.

4. A safety gate according to any preceding claim, wherein the wings are substantially triangular and have right-angled lower outer corners.

5. A safety gate according to any preceding claim, further comprising one or more lateral extension frames for attachment to one or both wings, to enable the gate to be clamped across thresholds of differing widths.

6. A safety gate according to any preceding claim, wherein the base extends the full width of the frame.

7. A safety gate according to any preceding claim, wherein the wicket is releasably secured to the wings in such a manner that it is suspended a distance above the base when the gate is closed, such that in relation to the angle of inclination of the hinge axis and the size of the wicket, the wicket may be opened at least a quarter-turn to a fully open position in which the under-surface of the wicket is at the same vertical level as the undersurface of the base.

8. A safety gate according to any preceding Claim,

5 wherein the means releasably securing the wicket to the wing is only releasable by raising the wicket, the hinge allowing a limited degree of such vertical movement.

9. A child-proof safety gate for a doorway or other threshold, comprising:

10 a stationary frame comprising two wings, having outer edges adapted to engage corresponding vertical sides of the threshold, and a base interconnecting the wings; and

o o o o
o o o o

o o o o
o o o o

o o o o
o o o o

o o o o
o o o o

o o o o
o o o o

15 a wicket, complementary in shape to the stationary frame, hinged to an inner edge of one of the wings, the hinge axis being inclined to the vertical in use such that the wicket tends to swing open about the hinge from a closed position, generally co-planar with the stationary frame, to an open position, under its own weight.

20

o o o o
o o o o

o o o o
o o o o

o o o o
o o o o

o o o o
o o o o

o o o o
o o o o

10. A safety gate according to claim 8, wherein the hinge is associated with a spring whose bias acts against the raising of the wicket.

25

o o o o
o o o o

o o o o
o o o o

11. A child-proof safety gate for a doorway or other threshold substantially as herein described with reference to Figures 1 to 3 or Figure 4 of the accompanying drawings.

30

DATED this 23rd day of May 1990

K.I.D. DESIGN GROUP LIMITED

By their Patent Attorneys

GRIFFITH HACK & CO.

35



7901S/MS

FIG. 1.

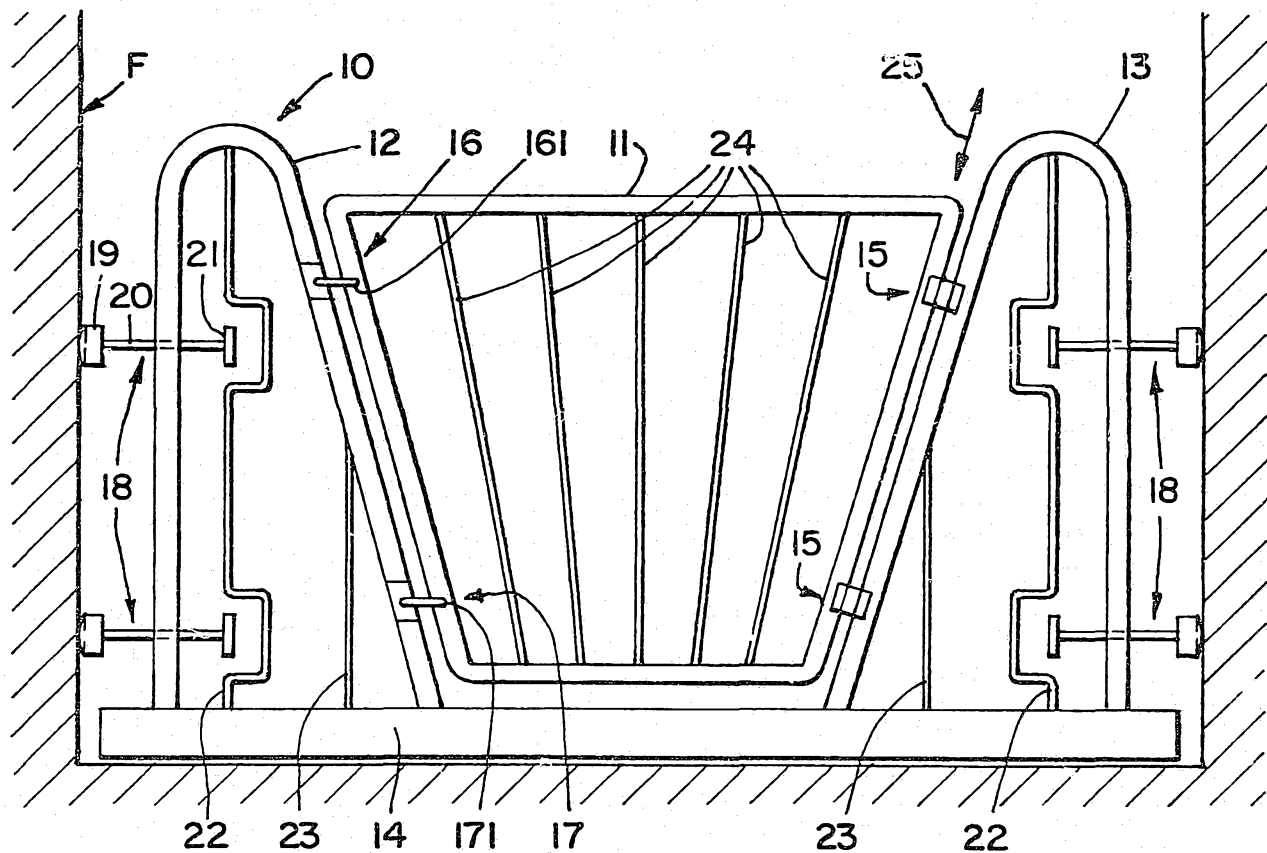

FIG. 2.

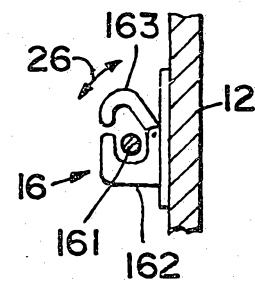
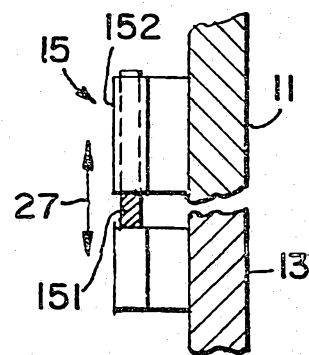

FIG. 3.



77213/87

