

(19) World Intellectual Property Organization  
International Bureau



(43) International Publication Date  
14 July 2005 (14.07.2005)

PCT

(10) International Publication Number  
WO 2005/063116 A1

- (51) International Patent Classification<sup>7</sup>: **A61B 5/00**
  - (21) International Application Number: PCT/IB2004/052862
  - (22) International Filing Date: 20 December 2004 (20.12.2004)
  - (25) Filing Language: English
  - (26) Publication Language: English
  - (30) Priority Data: 03104918.2 22 December 2003 (22.12.2003) EP
  - (71) Applicant (for all designated States except US): **KONINKLIJKE PHILIPS ELECTRONICS N. V.** [NL/NL]; Groenewoudseweg 1, NL-5621 BA Eindhoven (NL).
  - (72) Inventors; and
  - (75) Inventors/Applicants (for US only): **VAN BEEK, Michael Cornelis** [NL/DE]; c/o Philips Intellectual Property & Standards GmbH, Weissshausstr. 2, 52066 Aachen (DE). **LENDERINK, Egbert** [NL/DE]; c/o Philips Intellectual Property & Standards GmbH, Weissshausstr. 2, 52066 Aachen (DE). **HENDRIKS, Robert Frans Maria** [NL/DE]; c/o Philips Intellectual Property & Standards GmbH, Weissshausstr. 2, 52066 Aachen (DE).
  - (74) Agents: **VOLMER, Georg** et al.; Philips Intellectual Property & Standards GmbH, Weissshausstr. 2, 52066 Aachen (DE).
  - (81) Designated States (unless otherwise indicated, for every kind of national protection available): AE, AG, AL, AM, AT, AU, AZ, BA, BB, BG, BR, BW, BY, BZ, CA, CH, CN, CO, CR, CU, CZ, DE, DK, DM, DZ, EC, EE, EG, ES, FI, GB, GD, GE, GH, GM, HR, HU, ID, IL, IN, IS, JP, KE, KG, KP, KR, KZ, LC, LK, LR, LS, LT, LU, LV, MA, MD, MG, MK, MN, MW, MX, MZ, NA, NI, NO, NZ, OM, PG, PH, PL, PT, RO, RU, SC, SD, SE, SG, SK, SL, SY, TJ, TM, TN, TR, TT, TZ, UA, UG, US, UZ, VC, VN, YU, ZA, ZM, ZW.
  - (84) Designated States (unless otherwise indicated, for every kind of regional protection available): ARIPO (BW, GH, GM, KE, LS, MW, MZ, NA, SD, SL, SZ, TZ, UG, ZM, ZW), Eurasian (AM, AZ, BY, KG, KZ, MD, RU, TJ, TM), European (AT, BE, BG, CH, CY, CZ, DE, DK, EE, ES, FI, FR, GB, GR, HU, IE, IS, IT, LT, LU, MC, NL, PL, PT, RO, SE, SI, SK, TR), OAPI (BF, BJ, CF, CG, CI, CM, GA, GN, GQ, GW, ML, MR, NE, SN, TD, TG).
- Published:**  
— with international search report

[Continued on next page]

(54) Title: APPARATUS AND METHOD FOR PERFORMING ORTHOGONAL POLARIZED SPECTRAL IMAGING (OPSI)

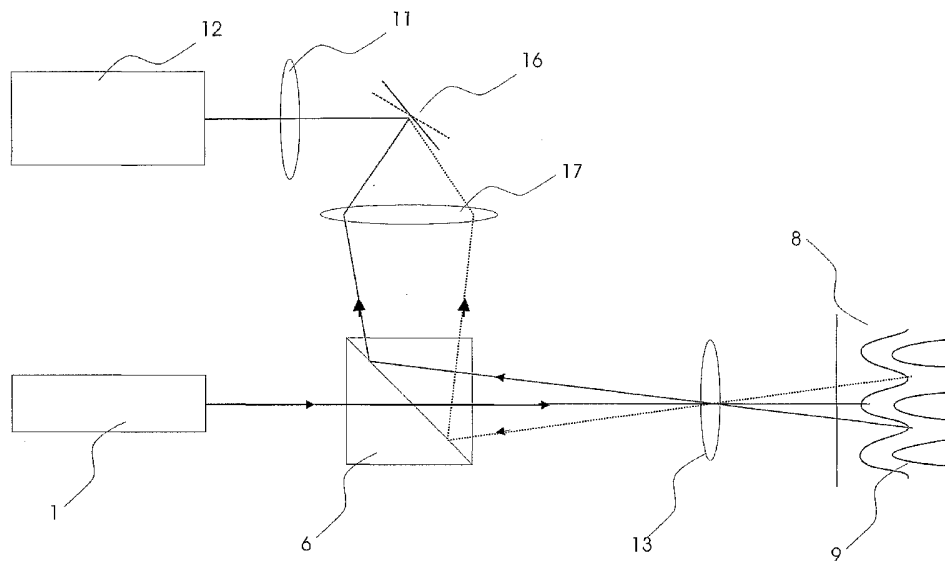

(57) Abstract: Provided is a method and an apparatus for detection of objects below the surface of diffuse scattering media, in particular blood capillaries in organs such as the skin of human beings, using Orthogonal Polarized Spectral Imaging (OPSI), according to the invention comprising the steps of: imaging the object in question at at least two different angles so as to obtain a shift of position in the imaging plane; and subsequently comparing relative shifts of objects in the two images so as to obtain coordinates of the imaged objects with respect to the organ surface.

WO 2005/063116 A1



---

*For two-letter codes and other abbreviations, refer to the "Guidance Notes on Codes and Abbreviations" appearing at the beginning of each regular issue of the PCT Gazette.*

## Apparatus and method for performing orthogonal polarized spectral imaging (OPSI)

The present invention relates to a method and system for detection of objects below the surface of diffuse scattering media, in particular blood capillaries in organs such as the skin of human beings, using Orthogonal Polarized Spectral Imaging (OPSI) as described by the preamble of independent patent claim 1.

5

It is a well know tendency in all areas of medical care to provide methods and systems that render possible a minimal or non-invasive treatment of patients inter alia to reduce risks as well as stress for the patient. In line with this tendency, projects have been set up to provide methods of non-invasive blood analysis. In Non-Invasive Blood Analysis, one of the possibilities is to measure the concentration of various analytes in blood in vivo by means of confocal Raman spectroscopy.

To achieve a Raman signal from blood instead of skin, the blood capillaries near the skin surface have to be visualized and the Raman detection volume has to be aimed at one of these capillaries. Blood capillaries close to the skin surface have a diameter of 5 to 15  $\mu\text{m}$ . Confocal detection keeps the source of the collected Raman signal well confined in all three dimensions in a spot of  $<5 \times 5 \times 10 \mu\text{m}^3$ . This makes it possible to collect a Raman signal from blood without a background signal from skin tissue if the focus is located in a blood capillary.

15  
20

In this respect, a simple, cheap, and robust method of visualizing blood vessels close to the surface of organs is said Orthogonal Polarized Spectral Imaging (OPSI). Medical applications of Orthogonal Polarization Spectral Imaging can be taken, for example, from WO 01/22741, which is incorporated by reference herein. A recent test has shown that it is also possible to use OPSI to visualize blood capillaries in the human skin. In OPSI, polarized light is incident on the skin through a polarizing beam splitter. Part of the light reflects directly from the surface (specular reflection). Another part penetrates into the skin, where it scatters once or several times before it is absorbed or is re-emitted from the skin surface

(diffuse reflection). In any of these scattering events there is a chance that the polarization of the incident light is changed. Light that is directly reflected or that penetrates only slightly into the skin will scatter only once or a few times before it is re-emitted and will mostly retain its initial polarization. On the other hand, light that penetrates more deeply into the skin undergoes multiple scattering and is depolarized before re-emitted back towards the surface. When looking at the subject through a second polarizer oriented precisely orthogonal to that of the first polarizer, light reflected from the surface or the upper parts of the skin is largely suppressed, whereas light that has penetrated deeper into the skin is mostly detected. As a result the image looks as if it were back-illuminated. Since wavelengths below 590 nm are strongly absorbed by blood, however, the blood vessels will appear dark in the OPSI image.

The reliability of a measured concentration of analytes in blood directly depends on the ability to direct the Raman detection volume inside a blood vessel. However, even though Orthogonal Polarized Spectral Imaging (OPSI) is a method of detecting blood capillaries in human skin, it is essentially a 2-dimensional technique, whereas a 3-dimensional image would be desirable to be able to aim the Raman detection volume exactly. While the lateral resolution of OPSI is of the same order of magnitude as the Raman technique, OPSI hardly provides any depth information. The only depth discrimination available is caused by the depth of focus of the imaging objective. As the capillary moves out of the focal plane, it is blurred. Using the sharpness of the imaged blood vessels to determine the depth of the vessels has several disadvantages: it is not very precise; when the capillary is seen as blurred it is not a priori clear whether the capillary is above or below the focal plane; when the capillary is seen as blurred it is not a priori clear what the distance is between the blood capillary and the focal plane. An additional complication is that even in-focus images of blood capillaries are blurred because of light scattering in the skin tissue above the blood capillary. The lack of reliable depth information makes it difficult to aim the Raman laser at a blood vessel.

Accordingly, it is an object of the present invention to provide a method and system for detection of objects below the surface of diffuse scattering media, in particular blood capillaries in organs such as the skin of human beings, using Orthogonal Polarized Spectral Imaging (OPSI), which provides a more precise localization of the objects, and in particular capillaries in the human skin.

This object is achieved by the features according to the independent claims, while the features as contained in the dependent claims describe preferred and useful embodiments.

5 Provided is a method for detection of objects below the surface of diffuse scattering media, in particular blood capillaries in organs such as the skin of human beings, using Orthogonal Polarized Spectral Imaging (OPSI), according to the invention comprising the steps of: imaging the object in question at at least two different angles so as to obtain a shift of position in the imaging plane; and subsequently comparing relative shifts of objects in the two images so as to obtain coordinates of the imaged objects with respect to the focal  
10 plane.

Accordingly, it is proposed to use a stereoscopic variety of OPSI to obtain depth information, wherein the blood capillaries are imaged at different angles, resulting in a shift of position in the image plane. It can be determined from the direction of the shift whether the blood capillary is above or below the focal plane, while the distance between the  
15 blood capillary and the focal plane can be calculated from the size of the shift. Stereoscopy is a well-known technique for conventional microscopy. The object is imaged at different angles, and depth information is obtained by comparing relative shifts of objects in the two images. The human brain does this automatically when the eyes separately view the two images. Image analysis algorithms are also able to extract this information and quantify it.

20 Modern stereomicroscopes are based on two different principles. In the so-called Greenough design, two identical objectives are used at different angles. In the so-called telescopic design or common objective design, two partial microscope systems are arranged in parallel with each other and use the same main objective. In a preferred embodiment of the invention, the angle between the light paths of the at least two images is  
25 chosen to be between 10 and 30 degrees.

Furthermore, non-invasive blood analysis by confocal Raman spectroscopy uses a relatively high magnification factor and high numerical aperture (NA) objective with a short working distance to focus the Raman laser and to collect the Raman signal. For ease of construction and alignment and because of space and cost limitations, it is advantageous to  
30 use the same objective for OPSI. There are basically two ways to obtain a stereoscopic image using a single objective: illuminating only a part of the objective with a parallel beam or illuminating the whole objective at a certain angle.

OPSI uses light with a wavelength of 540 to 580 nm for detecting blood vessels in human skin. A lateral resolution of 1  $\mu\text{m}$  is preferable for OPSI imaging, which

can be achieved by using a NA of 0.35. The relation between the depth resolution  $\Delta z$  and the stereoscopic angle  $\alpha$  is given by

$$\tan\alpha = 0,5\Delta x / \Delta z.$$

5

Where  $\Delta x$  is the lateral resolution of the system. The factor 0.5 arises because imaging from the left ( $-\alpha$ ) and from the right ( $+\alpha$ ) are compared. Some typical values are given in the Table below:

Depth resolution ( $\mu\text{m}$ )	Stereoscopic angle (degrees)
1	27
2	14
5	6

10

For a NA = 0.9 objective, the maximum angle at which light can travel in object space is  $64^\circ$ . For a lateral resolution of  $1 \mu\text{m}$ , an effective NA of 0.35 an angle of  $21^\circ$  is required. Therefore, the maximum stereoscopic angle (neglecting other limitations like geometric constraints in image space) is  $43^\circ$ . The highest depth resolution of  $0.54 \mu\text{m}$  is achieved at this angle.

15

Furthermore, an apparatus for stereoscopic Orthogonal Polarized Scattering Imaging (OPSI) is provided for imaging objects below the surface of diffuse scattering media, in particular blood capillaries in organs such as the skin of human beings, comprising at least a light source providing polarized light, an imaging device such as a CCD-camera, a beam splitter, which preferably is a polarized beam splitter, a focusing device such as an objective, or a mirror, and means for imaging the object at two different imaging angles, consecutively or at the same time. The light source is preferably arranged to illuminate a diffuse scattering medium, which upon this illumination illuminates the object with depolarized light. The means for imaging the object may be formed by two objectives having different imaging angles or by a single main objective, and a scanning mirror for shifting the imaging beam in its path from the polarizing beam splitter to the imaging device. The two imaging angles preferably differ by 10 to 30 degrees.

20

25

Furthermore, separate imaging devices may be provided for each image, or, as an alternative, a shutter for alternating transmission of one of the two images is provided,

which is preferably located between the polarizing beam splitter and the imaging device and which may be embodied as a rotating-aperture shutter, a liquid crystal cell shutter, or any other suitable means. The imaging device may be for example, a CCD or CMOS camera.

The apparatus may further comprise a data processor for determining a  
5 position of the object, which position includes at least information about the z-axis parallel to the optical axis.

The apparatus may further comprise a spectroscopic analysis system having a spectroscopic light source which may be laser for providing a spectroscopic light beam, a spectroscopic light beam positioning device for directing the spectroscopic light beam to the  
10 object in dependence of the position of the object determined by the data processor. The spectroscopic analysis system may be identical to that described in WO 02/057759.

Further features and advantages of the present invention will become more  
15 apparent for those skilled in the art upon reading of the following description of preferred embodiments in connection with the annexed Figures, in which:

Fig. 1 is a schematic representation of a setup for OPSI;

Fig. 2a is a schematic representation of the exit pupil of the imaging objective with OPSI light paths using parallel beams in plan view;

20 Fig. 2b is a side view of Fig. 2a;

Fig. 3 shows an embodiment of the OPSI setup using parallel imaging beams;

Fig. 4 shows an embodiment using the same objective and tilted imaging  
beams; and

25 Fig. 5 shows the schematic position of blood vessels in an image as a function of the viewing angle and position relative to the focal plane.

Figure 1 schematically shows a typical setup for OPSI, comprising a light  
source 1, such as a lamp, a laser, an LED, etc., a condenser 2, diaphragm 3, a color filter 4, a  
30 polarizer 5, a polarizing beam splitter 6, and an objective 7. Furthermore, Fig. 1 shows a skin 8 consisting of (a) epidermis, and (b) dermis, together with blood capillaries 9. Finally, an analyzer 10 is shown, wherein polarization is effected perpendicularly to polarizer 4, a lens 11, and a CCD camera 12.

Figure 2a is a plan view of an exit pupil 13 of the imaging objective with OPSI light paths using parallel beams 14, 15. A non-invasive blood analyzer uses an objective with a NA of 0.9. A lateral resolution of 1 or 2  $\mu\text{m}$  is required for OPSI imaging, which can be achieved by using an objective with a NA of 0.35. Since the NA required for OPSI (0.35) is much smaller than the NA available (0.9), it is possible to use only a fraction of the pupil 13 area for imaging. The different stereoscopic angles can be achieved by illuminating different areas of the pupil 13. Using parallel beams 14, 15, the blood vessels 9 in the focal plane are imaged in the same position if observed at the two stereoscopic angles. Vessels 9 that lie in front of or behind the focal plane have different positions in the two images. A possible embodiment is shown in Figure 3.

The position of the imaging beam in the objective pupil 13 can be shifted by means of a scanning (rotating) mirror 16 and a relaying lens 17. If the distance between this lens 17 and the scanning mirror 16 equals the focal distance of the relaying lens 17, a tilt of the mirror 16 results in a parallel displacement of the imaging beam in the objective pupil 13. The distance between the objective pupil 13 and the blood vessel 9 is equal to the focal distance of the objective pupil 13 (corrected for the refractive index of human skin).

An alternative embodiment is shown in Figure, 4, where the same elements as in the previous Figures have been provided with corresponding reference signs. A polarizing beam splitter 6 separates the light paths of the illumination system and the imaging system. The imaging system contains a scanning mirror 16 and a relaying lens 17 such that the pivot point on the scanning mirror 16 is imaged on the center of the objective lens 13. An imaging lens is used to image the focal plane of the objective lens 13 onto a CCD camera.

As the scanning mirror 16 performs a wobbling motion, the OPSI image moves. Objects that are in front of or above the focal plane will move less than objects behind or below the focal plane. Objects that are in the focal plane will move over a distance  $Mf \tan \beta$ , where  $M$  is the magnification factor of the OPSI system,  $f$  is the focal length of the objective, and  $\beta$  is the viewing angle through the microscope objective.  $\beta$  is related to the scanning angle  $\sigma$  of scanning mirror 16 as follows:  $\tan \beta = (A/B) \tan 2 \sigma$ , where  $A$  is the distance from the scanning mirror 16 to the relaying lens 17 and  $B$  is the distance from the relaying lens 17 to the objective lens 13.

Objects that are at a distance  $\delta$  above the focal plane will move over a distance that is slightly smaller,  $M(f - \delta) \tan \beta$ , whereas objects at a distance  $\delta$  below the focal plane will move over a distance that is slightly greater,  $M(f + \delta) \tan \beta$ , cf. Figure 5.



Figure 5 shows the schematic positions of blood vessels 18. The three blood vessels 18a, 18b, 18c shown in Figure 5 all overlap in the case of  $\beta = 0$ , but their projections on the focal plane all have different displacements for  $\beta \neq 0$ .

Besides the embodiments described above, other embodiments are possible such as, for example, a single imaging device which includes a replacement for the scanning mirror by a rotating wedge or by two shifting wedges. It is also possible to use two imaging devices looking through the objective at different angles. This has the advantage that there are no moving parts and that the images from both sides can be detected simultaneously. The amount of de-focus can be determined from the obtained images by means of a correlation function or by subtracting the two images.

Provided is a method and an apparatus for detection of objects below the surface of diffuse scattering media, in particular blood capillaries in organs such as the skin of human beings, using Orthogonal Polarized Spectral Imaging (OPSI), according to the invention comprising the steps of: imaging the object in question at least two different angles so as to obtain a shift of position in the imaging plane; and subsequently comparing relative shifts of objects in the two images so as to obtain coordinates of the imaged objects with respect to the organ surface.

It should be noted that the above-mentioned embodiments illustrate rather than limit the invention, and that those skilled in the art will be able to design many alternative embodiments without departing from the scope of the appended claims. In the claims, any reference signs placed between parentheses shall not be construed as limiting the claim. The word "comprising" does not exclude the presence of other elements or steps than those listed in a claim. The word "a" or "an" preceding an element does not exclude the presence of a plurality of such elements.

## CLAIMS:

1. Apparatus for performing Orthogonal Polarized Spectral Imaging (OPSI) for imaging objects below the surface of diffuse scattering media, in particular blood capillaries in organs such as the skin of human beings, comprising inter alia at least a light source (1) for providing polarized light, an imaging device (12), a beam splitter (6), a focusing device (7),  
5 and means for imaging the object at two different imaging angles.
2. Apparatus according to claim 1, characterized in that the means for imaging the object is formed by two objectives having different imaging angles.
- 10 3. Apparatus according to claim 1, characterized in that the means for imaging the object is formed by a single main objective (7), a scanning mirror (16), and a rotating wedge or two shifting wedges for shifting the imaging beam in its path from the polarizing beam splitter (6) to the imaging device (12).
- 15 4. Apparatus according to claim 1, characterized in that a separate imaging device (12) is provided for each image.
5. Apparatus according to claim 4, characterized in that a shutter is provided for transmitting the two images in alternation.  
20
6. Apparatus according to claim 5, characterized in that the shutter is located between the polarizing beam splitter (6) and the imaging device (12).
7. Apparatus according to claim 5, characterized in that the shutter is a rotating-  
25 aperture shutter.
8. Apparatus according to claim 5, characterized in that the shutter is a liquid crystal cell shutter.

9. Apparatus according to claim 1, characterized in that the two imaging angles differ by 10 to 30 degrees.
10. Apparatus according to claim 1, characterized in that the imaging devices are  
5 CCD-cameras.
11. Apparatus according to claim 1, characterized in that the imaging devices are CMOS-sensors.
- 10 12. Apparatus according to claim 1, characterized in further comprising a data processor for determining a position of the object, the position including at least information about the z-axis which is parallel to the optical axis.
13. Apparatus according to claim 12, characterized in further comprising a  
15 spectroscopic analysis system, with a spectroscopic light source and a spectroscopic light beam positioning device for directing the spectroscopic light beam to the object in dependence of the position of the object determined by the data processor.
14. A method for detection of objects below the surface of diffuse scattering  
20 media, in particular blood capillaries in organs such as the skin of human beings, using Orthogonal Polarized Spectral Imaging (OPSI), comprising the steps of:
- imaging the object in question at at least two different angles so as to obtain a shift of position in the imaging plane; and
  - comparing relative shifts of objects in the two images so as to obtain  
25 coordinates of the imaged objects with respect to the organ surface.
15. Method according to claim 14, characterized in that it is determined on the basic of the direction of the shift whether the imaged object is above or below the focal plane.
- 30 16. Method according to claim 14, characterized in that the distance between the object and the focal plane is calculated from the size of the shift.
17. Method according to claim 1, characterized in that the imaging angle is chosen to be between 10 and 30 degrees.

18. Method according to claim 14, characterized in that a single objective (7) is used for imaging the object.
- 5 19. Method according to claim 18, characterized in that part of the objective (7) is illuminated with a parallel beam so as to obtain the at least two images.
20. Method according to claim 18, characterized in that the entire objective (7) is illuminated at a defined angle so as to obtain the at least two images.

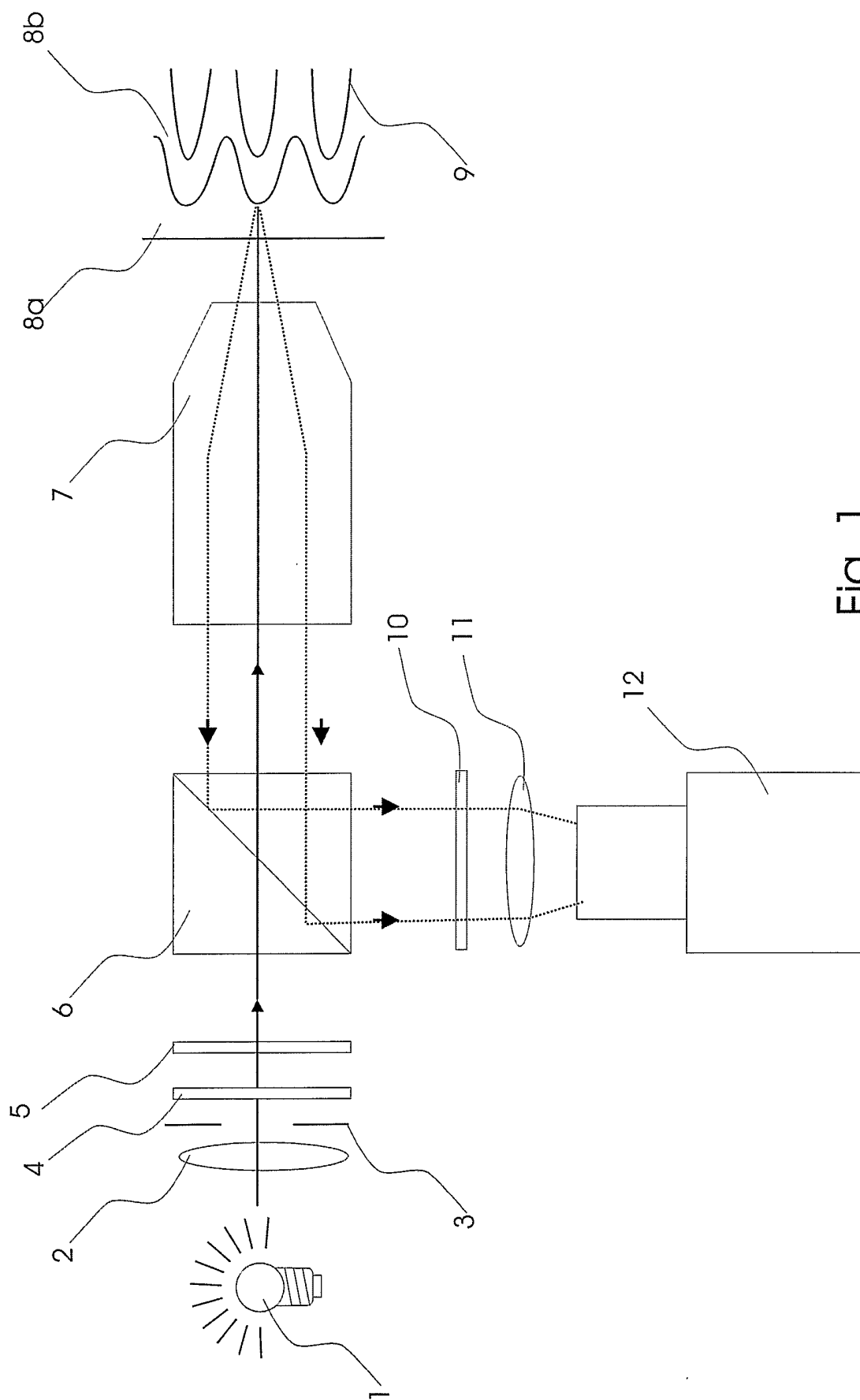

Fig. 1

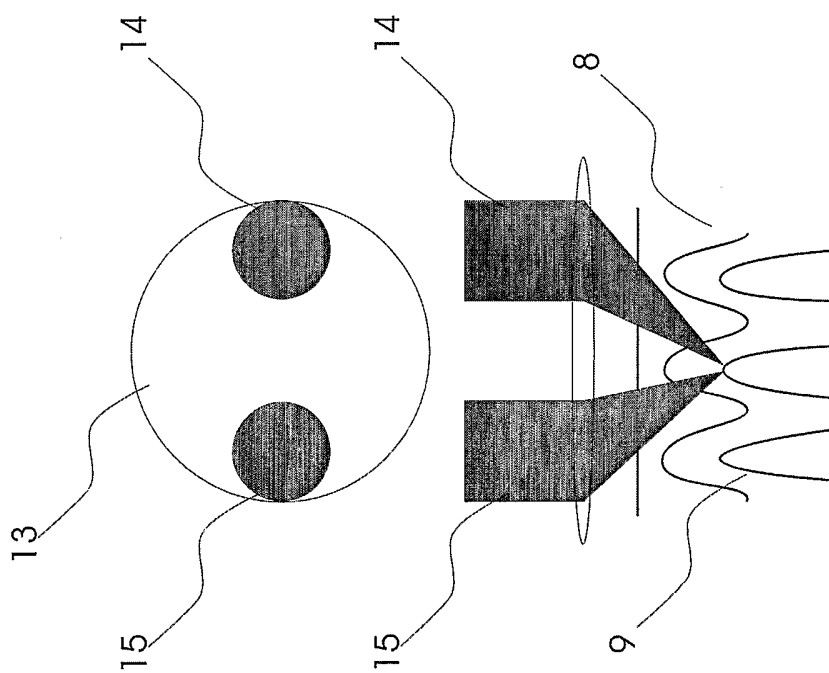

Fig. 2a

Fig. 2b

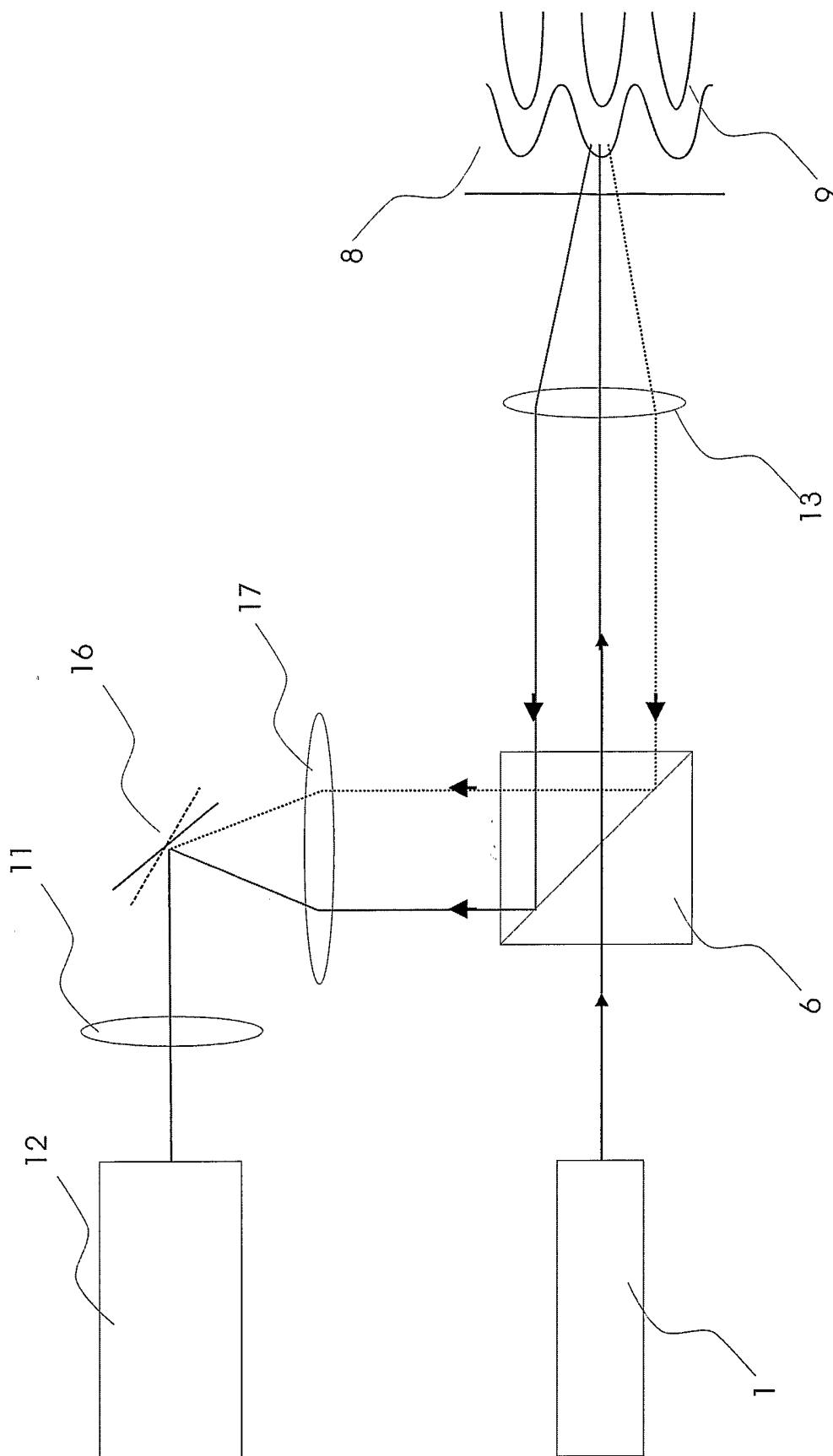

Fig. 3

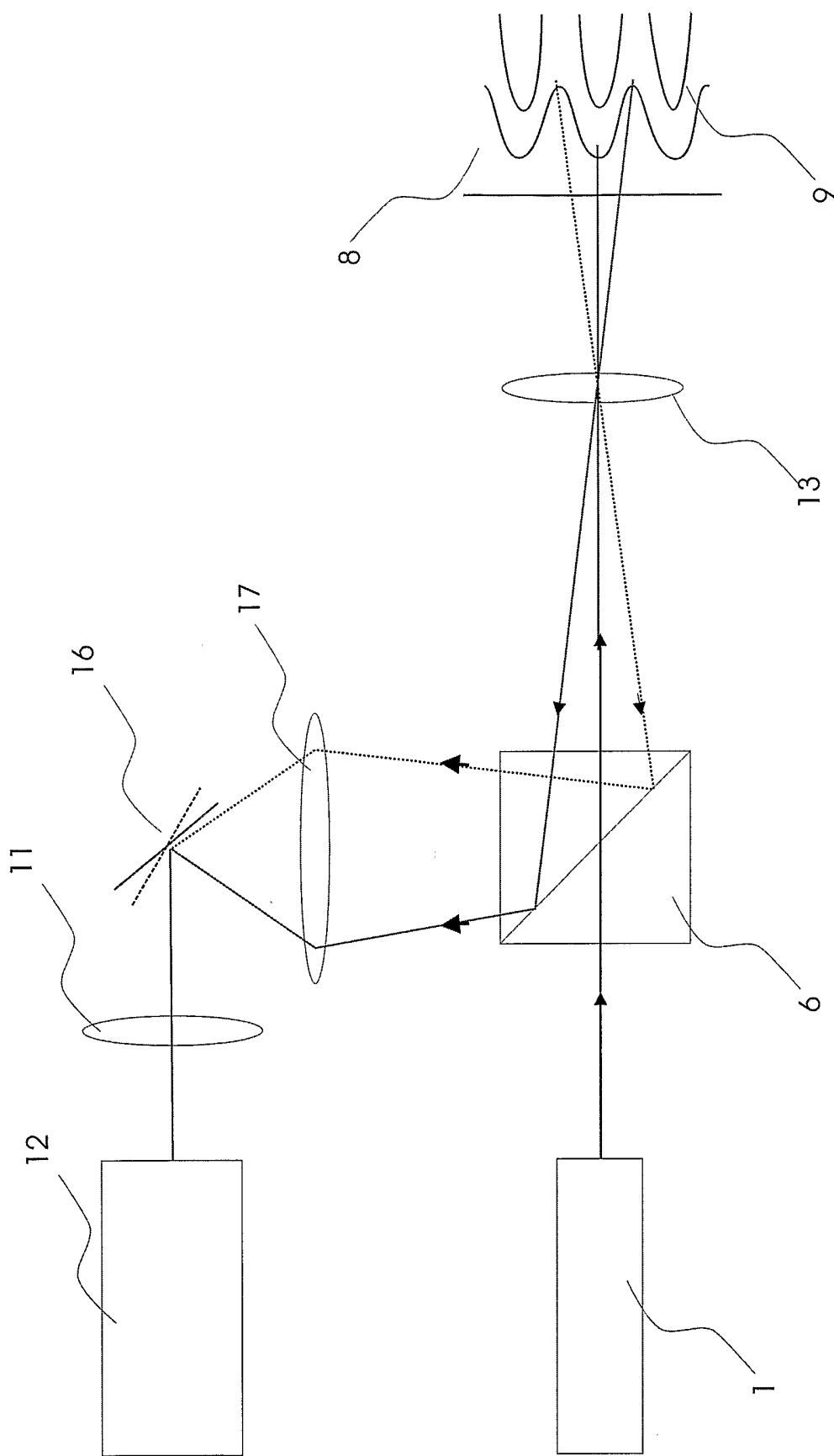

Fig. 4



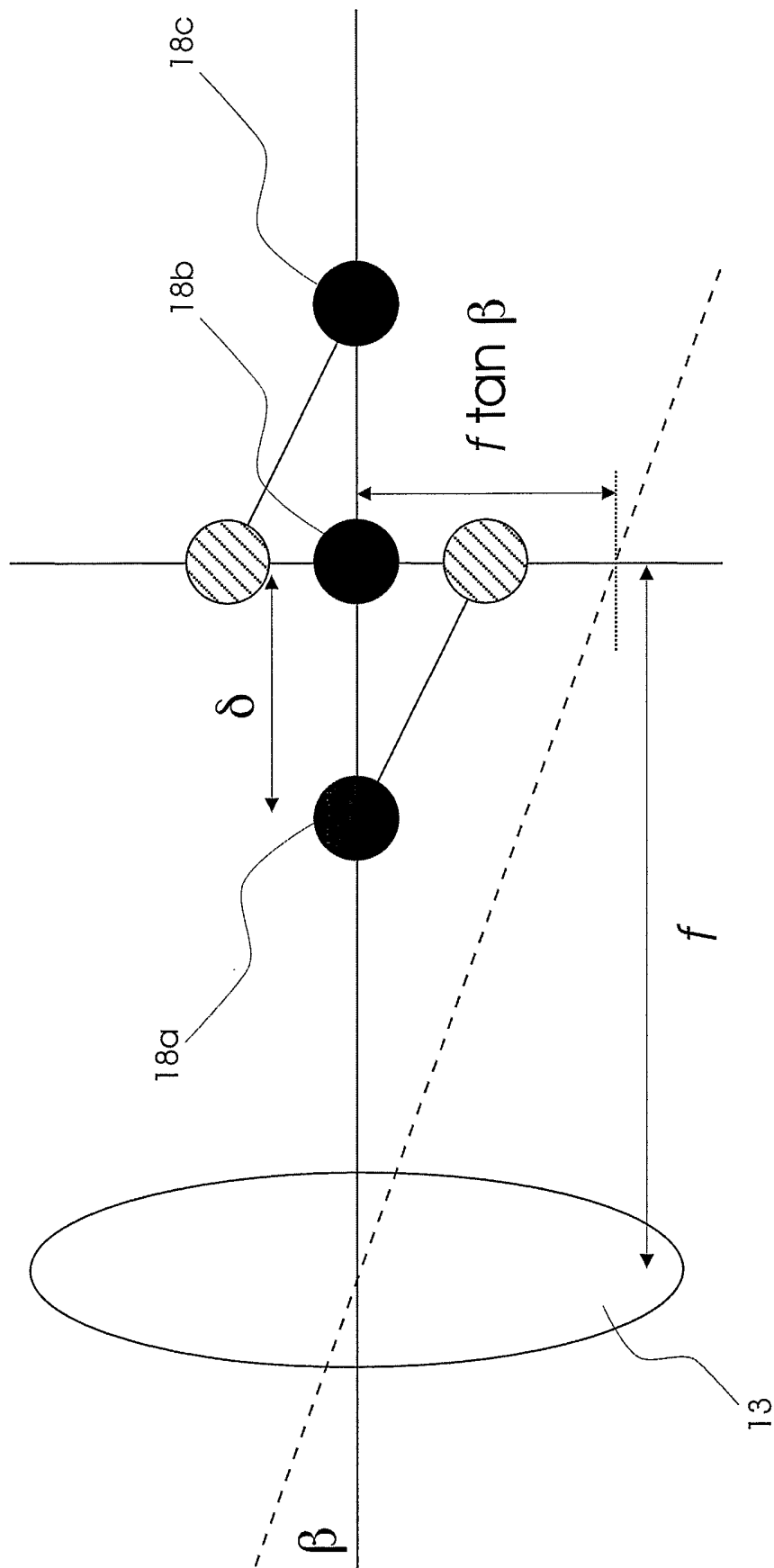

Fig. 5

## INTERNATIONAL SEARCH REPORT

Int. Patent Application No  
PCT/IB2004/052862

**A. CLASSIFICATION OF SUBJECT MATTER**  
IPC 7 A61B5/00

According to International Patent Classification (IPC) or to both national classification and IPC

**B. FIELDS SEARCHED**

Minimum documentation searched (classification system followed by classification symbols)  
IPC 7 A61B G02B

Documentation searched other than minimum documentation to the extent that such documents are included in the fields searched

Electronic data base consulted during the international search (name of data base and, where practical, search terms used)

EPO-Internal, INSPEC, MEDLINE

**C. DOCUMENTS CONSIDERED TO BE RELEVANT**

Category °	Citation of document, with indication, where appropriate, of the relevant passages	Relevant to claim No.
X	US 2003/109774 A1 (LUCASSEN GERHARDUS WIHELMUS ET AL) 12 June 2003 (2003-06-12)  paragraphs '0035!, '0036!	1, 3, 10, 12-16, 18-20
X	US 5 836 872 A (KENET ET AL) 17 November 1998 (1998-11-17)  column 4, line 50 - line 57 column 6, line 15 - line 20 column 7, line 60 - column 8, line 2 column 8, line 50 - line 54 column 9, line 22 - line 28 column 14, line 21 - line 24	1, 2, 4, 5, 12, 14, 18-20
A	US 5 867 309 A (SPINK ET AL) 2 February 1999 (1999-02-02) figures 1, 9, 16	1, 3-8

Further documents are listed in the continuation of box C.

Patent family members are listed in annex.

° Special categories of cited documents :

- \*A\* document defining the general state of the art which is not considered to be of particular relevance
- \*E\* earlier document but published on or after the international filing date
- \*L\* document which may throw doubts on priority claim(s) or which is cited to establish the publication date of another citation or other special reason (as specified)
- \*O\* document referring to an oral disclosure, use, exhibition or other means
- \*P\* document published prior to the international filing date but later than the priority date claimed

- \*T\* later document published after the international filing date or priority date and not in conflict with the application but cited to understand the principle or theory underlying the invention
- \*X\* document of particular relevance; the claimed invention cannot be considered novel or cannot be considered to involve an inventive step when the document is taken alone
- \*Y\* document of particular relevance; the claimed invention cannot be considered to involve an inventive step when the document is combined with one or more other such documents, such combination being obvious to a person skilled in the art.
- \*&\* document member of the same patent family

Date of the actual completion of the international search

8 March 2005

Date of mailing of the international search report

17/03/2005

Name and mailing address of the ISA

European Patent Office, P.B. 5818 Patentlaan 2  
NL - 2280 HV Rijswijk  
Tel. (+31-70) 340-2040, Tx. 31 651 epo nl,  
Fax: (+31-70) 340-3016

Authorized officer

Knüpling, M

## INTERNATIONAL SEARCH REPORT

In International Application No  
PCT/JP2004/052862

Patent document cited in search report	Publication date	Patent family member(s)	Publication date	
US 2003109774	A1	12-06-2003	US 2002133065 A1	19-09-2002
			EP 1272828 A1	08-01-2003
			JP 2004529321 T	24-09-2004
			CN 1455861 A	12-11-2003
			CN 1455862 A	12-11-2003
			EP 1255979 A1	13-11-2002
			WO 02057759 A1	25-07-2002
			WO 02057758 A1	25-07-2002
			JP 2004518125 T	17-06-2004
			US 5836872	A
US 5241468 A	31-08-1993			
AU 5524990 A	16-11-1990			
WO 9013091 A1	01-11-1990			
US 5867309	A	02-02-1999	DE 59508357 D1	21-06-2000
			WO 9527226 A2	12-10-1995
			EP 0753164 A1	15-01-1997
			EP 0949525 A1	13-10-1999
			JP 9511343 T	11-11-1997
			US 2002057493 A1	16-05-2002
			US 6069733 A	30-05-2000
			US 6337765 B1	08-01-2002