

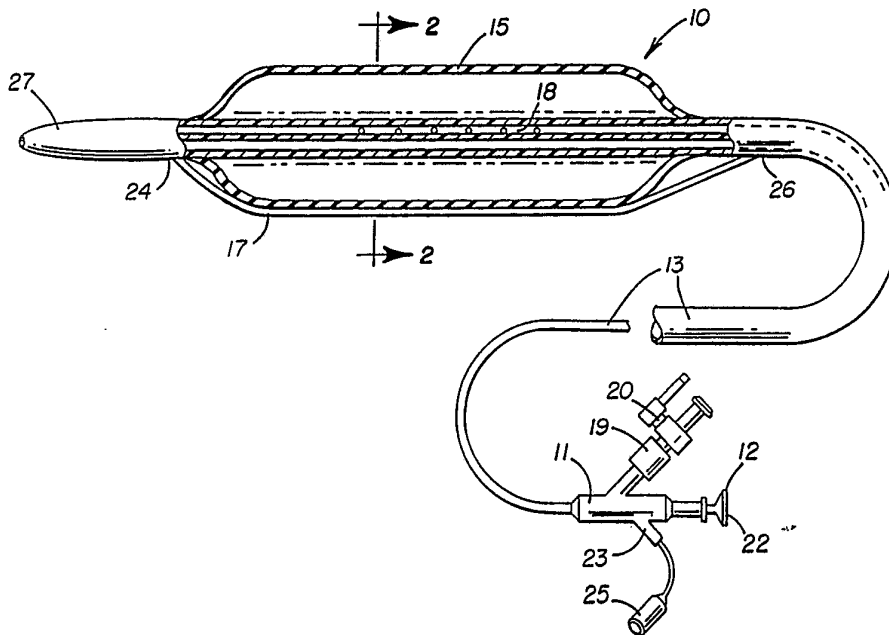

INTERNATIONAL APPLICATION PUBLISHED UNDER THE PATENT COOPERATION TREATY (PCT)

<p>(51) International Patent Classification ⁵ : A61B 17/32, A61M 29/02</p>	A1	<p>(11) International Publication Number: WO 91/17714</p> <p>(43) International Publication Date: 28 November 1991 (28.11.91)</p>
<p>(21) International Application Number: PCT/US91/02857</p> <p>(22) International Filing Date: 25 April 1991 (25.04.91)</p> <p>(30) Priority data: 522,148 11 May 1990 (11.05.90) US</p> <p>(71) Applicant: APPLIED UROLOGY, INC. [US/US]; 26061 Merit Circle, #101, Laguna Hills, CA 92653 (US).</p> <p>(72) Inventor: CLAYMAN, Ralph, V., M., D. ; 14 Ridgemoor Drive, St. Louis, MO 63105 (US).</p> <p>(74) Agent: MYERS, Richard, L.; Applied Urology, Inc., 26061 Merit Circle, #101, Laguna Hills, CA 92653 (US).</p>		<p>(81) Designated States: AT (European patent), BE (European patent), CA, CH (European patent), DE (European patent), DK (European patent), ES (European patent), FR (European patent), GB (European patent), GR (European patent), IT (European patent), JP, LU (European patent), NL (European patent), SE (European patent).</p> <p>Published <i>With international search report.</i></p>

(54) Title: DILATATION CATHETER ASSEMBLY WITH CUTTING ELEMENT



(57) Abstract

A dilatation catheter assembly (10) is set forth which permits dilatation and incision of tissue whereby trauma and damage to the tissue due to uncontrolled tearing is reduced or eliminated. The assembly comprises an elongated tubular body (13) having a distal end that carries a dilatation bladder (15) and cutting element (17) carried on the exterior of the bladder and that moves radially in concert with the exterior of the bladder as the bladder is inflated and deflated. The bladder is not linearly extensible and is extensible only to a specified volume and/or the cutting element utilized is a radio frequency cutting element.

FOR THE PURPOSES OF INFORMATION ONLY

Codes used to identify States party to the PCT on the front pages of pamphlets publishing international applications under the PCT.

AT	Austria	ES	Spain	MG	Madagascar
AU	Australia	FI	Finland	ML	Mali
BB	Barbados	FR	France	MN	Mongolia
BE	Belgium	GA	Gabon	MR	Mauritania
BF	Burkina Faso	GB	United Kingdom	MW	Malawi
BG	Bulgaria	GN	Guinea	NL	Netherlands
BJ	Benin	GR	Greece	NO	Norway
BR	Brazil	HU	Hungary	PL	Poland
CA	Canada	IT	Italy	RO	Romania
CF	Central African Republic	JP	Japan	SD	Sudan
CG	Congo	KP	Democratic People's Republic of Korea	SE	Sweden
CH	Switzerland	KR	Republic of Korea	SN	Senegal
CI	Côte d'Ivoire	LI	Liechtenstein	SU	Soviet Union
CM	Cameroon	LK	Sri Lanka	TD	Chad
CS	Czechoslovakia	LU	Luxembourg	TG	Togo
DE	Germany	MC	Monaco	US	United States of America
DK	Denmark				

- 1 -

Description

DILATATION CATHETER ASSEMBLY WITH CUTTING ELEMENT

Technical Field

The present invention is in the field of surgical devices, particularly dilatation catheters. Specifically, it concerns a dilatation catheter whose expandable member carries a cutting element which concurrently incises the tissue being subjected to dilatation forces, thereby obtaining a clean and directed incision and reducing trauma and damage to such tissue from the dilatation forces.

5

10

- 2 -

Background Of The Invention

Dilatation catheters are used to dilate body vessels, orifices and conduits such as an artery narrowed by atherosclerotic plaque and/or fibromuscular disease or to dilate a constricted or obstructed ureter or urethra. The prior art devices basically consist of an elongated catheter having an inflatable extensible elastomeric (rubber-like) or non-extensible variety, at or near its distal end. A guide wire or other axial support means is often included to improve the torque control or "steerability" of the apparatus.

The major advantage of dilatation catheter use over conventional surgery is that it is less invasive. Nonetheless, the tissue that is stressed is often also subjected to significant trauma. As the bladder expands, it exerts pressure on the surrounding tissue, causing the tissue to compress, deform and expand. The tissue, of course, has an inherent limit of deformability. When the dilation pressure causes the tissue to deform beyond that limit, the tissue tears apart, often to form a jagged wound, with considerable damage, trauma, pain and bleeding. A principal object of the present invention is to provide a dilatation catheter that permits tissue to be stressed, even beyond its limit of deformability, without experiencing uncontrolled tearing and the undesirable conditions associated therewith.

U.S. Patent 4,747,405, issued to Leckrone on May 31, 1988, U.S. Patent 4,669,469, issued June 2, 1987 to Gifford, III, et al., and PCT/U.S. 86/02617 application of Leckrone, published June 16, 1988 are each concerned with atherectomy devices wherein a balloon is used to position an

- 3 -

opening in a casing about an obstruction such as plaque. The balloon does not carry a cutting element to incise tissue but does carry means for disintegrating the plaque which is generally entrapped within a hole in the casing. The balloon basically positions the hole in the casing up against and about the plaque. Thus, the balloon is not symmetrically located within the blood vessel, an outward cutting element is not present and the blood vessel is not torn by the dilation force.

U.S. Patent 4,799,479, issued January 24, 1989 to Spears, shows use of a balloon to open up an artery and then utilizes a laser, heated wire mesh, or the like, to heat up blood trapped between the media and the plaque so that dilation will be maintained and so that a smooth wall will result.

U.S. Patent 4,273,128, issued June 16, 1981 to Lary, teaches the use of a balloon with a knife blade, or a series of knife blades, longitudinally distally removed from the balloon.

Soviet Patent 599802 published in 1976 utilizes a balloon which is located within a tube. When the balloon is extended this forces a cutting element through a window in the tube to accomplish fenestration. Pressure is not exerted on body tissue as the bladder is within the tube.

German Patent 3,402,573 is concerned with a single lumen multi-purpose catheter with an extensible elastic balloon with a cutting facility for treatment of stenosis. This patent utilizes three balloons of equal size at the distal end of the catheter. Each elastomeric balloon carries small cutter elements which extend in the longitudinal direction and which are held in a

- 4 -

trough made of hard rubber or plastic. Prior to use the cutters lie hidden in longitudinal slots of the relatively thick wall of the one-lumen catheter. Threads anchor the plate when the balloons are inflated thereby limiting the degree of penetration of adjacent plaque (and possibly tissue).

U.S. Patent 4,484,579, issued to Meno, et al, November 27, 1984 is concerned with a commissurotomy catheter which serves for separating fused heart valve leaflets. The device includes four balloons carried by a single catheter structure. In use the device fits through the valve with two balloons on each side of the valve. A nylon or similar string is attached between the pairs of balloons on each side of the valve. The balloons can be alternately expanded and contracted thereby causing the strings strung between each pair of balloons to saw or pulsate into fused portions of the heart valve leaflets and separate them. The actual cutting portion of the string is not carried on the exterior of the balloons.

U.S. Patent 4,660,560, issued April 28, 1987 to L. A. Klien discloses an apparatus for relieving obstruction of the urinary tract caused by an enlarged prostate gland. A balloon is inserted via a urethral catheter and then is expanded until the prostate has been forced back from around the urethra. The apparatus of this patent does not employ a cutter of any sort.

The above-mentioned patents do not make use of a cauterizing (i.e. an electrosurgical or radio frequency surgical) cutting element. Nor do the above discussed patents either suggest or show any advantages for utilizing an inextensible bladder

- 5 -

or balloon, i.e., a balloon which is not elastomeric (or elastic) and which can be inflated to only a selected shape and volume and which cannot extend longitudinally when pressurized. Furthermore, the above discussed patents are not concerned with a radially symmetrical, generally cylindrical in shape when expanded, balloon which extends longitudinally along a body passage and a cutting element which extends longitudinally along and generally parallel to the balloon, which balloon creates a substantially uniform tangential tension in tissue being cut, and which cutting element at the same time performs the necessary cutting whereby a clean longitudinally extending incision results and uncontrolled tearing of the tissue does not occur.

In radio frequency electrosurgical cutting a radio frequency current is allowed to pass from an active cutting electrode through a patient's tissue and into a grounding pad or cable. The current cuts tissue at the active cutting electrode, the cutting rate being dependant on current density through the tissue in that area. At low current density heat is generated but no cut is achieved. At high current density fast cutting occurs.

Current density depends on the voltage applied and can be controlled utilizing an adjustment present on a conventional generator utilized for this purpose. The current density also depends on the series impedance of the overall circuit. Series impedance is equivalent to the sum total of the resistance to the current throughout the circuit. It is affected by the material and the design of the active electrode, by the patient, by the type of tissue to be cut,

- 6 -

and by the condition of contact established
between the patient and the grounding pad as well
as by the location of the pad relative to the
cutting site. During surgery, the generator
5 setting is usually adjusted to compensate for this
variability and to reflect the surgeon's
preference. Generators used in this type of
surgery have a wide range of power output to
accommodate a variety of procedures and devices.
10 For example, the generator can be adjusted to cut
tissue, or to cauterize adjacent already cut or
torn tissue, to do both.

The objective in electrosurgical cutting is
to heat the tissues cells so rapidly that they
15 explode into steam leaving a cavity in the cell
matrix. The heat is meant to be dissipated in the
steam and to not conduct through the tissue to
thereby dry out adjacent cells. When the
electrode is moved and fresh tissue is contacted
20 new cells are exploded and the incision is made.
Such electrosurgical cutting involves the sparking
of the current to the tissue. The current
utilized is in the radio frequency range and
operates by the radio frequency current jumping
25 across an air gap to the tissue. This is known as
sparking.

An explanation of electrosurgical cutting
theory can be found in the SSE3B Instruction
Manual published by Valleylab of Boulder, Colorado
30 on April 1, 1979.

An advantage of electrosurgical cutting,
particularly if it is performed utilizing a
cutting electrode as disclosed in copending
application Serial No. _____, of Buelna,
35 commonly assigned herewith, which is hereby
incorporated herein in its entirety by reference,

- 7 -

is that over heating of adjacent tissue with accompanying desiccation and damage is limited or prevented. Thus, what one can obtain is a clean cut without damage to adjacent tissue. A clean controlled cut is particularly desirable to assure that tearing does not occur in a direction away from the desired orientation of the cut.

The present invention is directed to overcoming one or more of the problems as set forth above.

Disclosure Of Invention

In accordance with an embodiment of the invention a dilatation catheter assembly comprises in combination: an elongated tubular body having a distal end carrying a radially dilatable inextensible longitudinally extending member adapted to be positioned longitudinally along a body conduit and to dilate in a radially symmetrical manner and exert pressure on surrounding body tissue to provide a substantially uniform tangential tension therein; means for dilating the dilatable member to a constant inextensible volume and a cutting element carried on the exterior of the dilatable member that moves radially in concert with the exterior of the dilatable member and is adapted to incise said tissue, thereby reducing damage to said tissue from dilation forces.

In accordance with another embodiment of the invention a dilation catheter assembly comprises an elongated tubular body having a distal end carrying a radially dilatable member adapted to be positioned in body conduit and exert pressure on surrounding body tissue; means for dilating the dilatable member and an

- 8 -

electrosurgical cutting element carried on the exterior of the dilatable member that moves radially in concert with the exterior of the dilatable member and that is adapted to incise the tissue, thereby reducing damage to the tissue from dilation forces.

In use the novel catheter of the invention concurrently exerts pressure on the tissue thereby placing it under tension and makes a clean, sharp generally longitudinally extending incision in the tissue while the tissue is subjected to the dilatation forces exerted by the dilating member. The incision allows the tissue to separate along a predetermined path and in a relatively clean, trauma-free manner as compared to the uncontrolled tearing that occurs when using prior devices.

Accordingly, another aspect of the invention is a method for dilating a body conduit, vessel or orifice comprising: inserting thereinto a dilatation catheter assembly comprising an elongated tubular body having a distal end carrying a radially dilatable inextensible member adapted to be positioned in a body conduit and to dilate in a radially symmetrical manner and exert pressure on surrounding body tissue to provide a substantially uniform tangential tension therein and a cutting element carried on the exterior of the dilatable member; dilating the inextensible dilatable member to an extent that causes the tissue to be stressed by the dilatable member; incising the stressed tissue using the cutting member; radially contracting the dilatable member to cause the dilatable member and cutting element to disengage the tissue; and withdrawing the dilatation catheter assembly therefrom. The dilating and incising steps are suitably repeated

- 9 -

until the dilatable member has reached a desired volume prior to the radial contracting step.

Still another aspect in accordance with the present invention is a method for dilating a body conduit, vessel or orifice. The method comprises inserting thereinto a dilation catheter assembly comprising an elongated tubular body having a distal end carrying a radially dilatable member adapted to dilate and exert pressure on surrounding body tissue and an electrosurgical cutting element carried on the exterior of the dilatable member; dilating the dilatable member to an extent that causes the tissue to be stressed by the dilatable member; activating the electrosurgical cutting element such that the stressed tissue is incised by the cutting element; discontinuing activation of the electrosurgical cutting element; radially contracting the dilatable member to cause the dilatable member and cutting element to disengage the tissue; and withdrawing the dilation catheter assembly therefrom. The dilating and incising steps are suitably repeated until the dilatable member has reached a desired volume prior to the radial contracting step.

Brief Description Of The Drawings

The invention will be better understood by reference to the figures of the drawings wherein like numbers denote like parts throughout and wherein:

Figure 1 is a partly cross-sectional, isometric view of one embodiment of the invention catheter;

Figure 2 is a cross-sectional view taken along line 2-2 of Figure 1;

- 10 -

Figure 3 is a prospective, schematic sectional view of a portion of another embodiment of the invention catheter positioned within a body conduit;

5 Figure 4 is a sectional, side view of the embodiment of Figure 3 in its deflated state;

Figure 5 is a sectional side view of the embodiment of Figure 3 in its inflated state;

10 Figure 6 is a cross-sectional view along line 6-6 of Figure 5;

Figure 7 is a sectional elevational view of another embodiment of the invention; and

15 Figure 8 is a view similar to Figure 1 and which includes means for selectively incising more deeply into a patient's tissue.

Best Mode For Carrying Out Invention

20 Figure 1 depicts a dilatation catheter assembly, generally designated 10, that may be used for dilating a body vessel or conduit, such as a ureter or urethra, to treat a blockage or other obstruction. The main elements of catheter assembly 10 are: an adapter 11 that defines the proximal end 12 of the assembly 10 and a site for various ports to the assembly 10; a triple lumen catheter body 13 (Figure 2); an inflatable inextensible balloon or bladder member 15; and a cutting element 17, very preferably a radio frequency cutting element activatable by a radio
25 frequency power source. The electrosurgical cutting element or electrode 17 is in the nature of a wire which runs along generally parallel to the longitudinally extending inflatable bladder 15. In use, the bladder 15 is inserted
30 longitudinally into a body conduit to the position where a surgical cut is required. The bladder 15
35

- 11 -

is then inflated (an inextensible bladder is generally used) to a desired pressure about 1 atmosphere) and allowed to expand to occupy the space in the body vessel or conduit. Radio frequency current is then passed through the cutting element 17. This leads to the wire being moved outwardly and incising adjacent tissue in that direction. Thereafter, the pressurization and incising steps are suitably repeated (the pressure drops each time incising occurs) as many times as is necessary until the bladder is fully inflated. In this way, the depth of the incision is controlled by the size chosen for the inextensible bladder 15 and tearing is avoided by making successive cuts rather than exerting a very large pressure within the bladder and overstressing the body conduit.

The material used for the wire can be any of the materials currently used for electrosurgical cutting wires. For example, the wire can be made of stainless steel or tungsten. In accordance with the teachings in the previously mentioned copending Buelna patent application a sheath with a slit in it, the slit facing away from the bladder 15, surrounds the cutting element 17. As seen in Figure 2, one of the three lumens serves as an inflation/deflation passageway 18, a second serves as a drainage/infusion passageway, and a third carries cutting element 17.

In accordance with the present invention the inflatable balloon or bladder member 15 is of the inextensible or constant volume variety, that assumes, when expanded, a specific size and shape. Thus, the balloon member 15 cannot extend significantly longitudinally within a body conduit beyond its selected length. And, further, it can

- 12 -

only extend radially to a selected radius, thus
controlling the depth of the incision. Since the
balloon member 15 cannot extend longitudinally, as
can elastic or elastomeric balloons, it must exert
5 the force caused by inflation of the balloon
member 15 radially against an enclosing body
conduit or the like. In contrast, if an elastic
or elastomeric balloon is expanded within a body
conduit which has one portion particularly
10 narrowed and particularly resistant to expansion,
the balloon will simply elongate rather than
acting radially outwardly against the
constriction. What is happening is a balance of
forces in the balloon which then expands in the
15 direction of least resistance.

In accordance with the present invention it
is preferred to utilize a radio frequency cutting
element 17 for a number of reasons. One reason is
that a radio frequency cutting element 17 will not
20 perform any cutting unless and until it is
activated by passing a radio frequency current
through it. As a result, accidental cuts cannot
be made away from the area where cutting is
desired. And, with proper control cutting can be
25 very sharply defined leading to a clean incision
without tearing. This radio frequency cutting or
cauterizing technique can, thus, provide
significant advantages over the use of prior art
cutters in an apparatus of the nature disclosed
30 herein.

In accordance with the present invention
the balloon member 15 generally extends
longitudinally along the body conduit and is
generally symmetrically placed and expandable
35 therein. In this manner, as the balloon member 15
is expanded, it exerts a substantially equal

- 13 -

tangential tension upon the tissue defining the body conduit. This results in the incision by the cutting element 17, which would generally proceed parallel to the balloon member 15, being particularly clean. In essence, the incision when made in this manner proceeds longitudinally along the body cavity and will generally not go off at an angle as might be the case if the tangential tension in the body conduit was not substantially uniform.

In accordance with the most preferred embodiment of the present invention the cutting element 17 is a radio frequency cutting element and is parallel to the bladder member 15, the bladder member 15 extends longitudinally along the body conduit and is of an inextensible (non-elastic, non-elastomeric) nature and is symmetrically placed within the body cavity so that on expansion it exerts a substantially uniform tangential tension upon the tissue defining the body cavity. This allows all of the advantages of the present invention to be realized at one and the same time.

The adapter 11 serves as a site for a bladder inflation/deflation port 19 that is attached to a source of inflation medium (not shown) for inflating the bladder member 15 or a suction source (not shown) for deflating the bladder member 15. Port 19 has a valve 20 for regulating the inflation medium or suction, as the case may be. Port 19 connects into the proximal end of an inflation/deflation passageway 18 that extends from the port 19 to the bladder member 15. The adapter 11 also serves as a site for the drainage tube inlet/outlet port 22 and a cutting element port 23. The drainage port 22 is

- 14 -

connected to the proximal end of the lumen that carries a stylet or guide wire. The drainage port 22 may serve as a site for removing fluid from the lumen or as a site for infusing fluid into the lumen. The distal end of the catheter body has a series of drain holes 24 to facilitate flushing the lumen with fluid or voiding the bladder member 15. A "banana plug" cutting element connector 25 is affixed to the end of the cutting element port and the cutting element 17 extends from the connector through the lumen of the catheter body 13 and exits therefrom via an aperture 26 and continues along the exterior of the bladder member 15. The cutting element 17 can consist of a thin wire which has an external incising edge that faces outwardly from the bladder member 15. Alternatively, the cutting element 17 may be a sharp edge, beam, or, more preferably, a radio frequency cutting or cauterizing element 17. The element/bladder is/are constructed (e.g., the element 17 is flexible or expandable) such that the cutting element 17 is carried on the exterior of the bladder member 15 (at least when the bladder member 15 is inflated) but is not capable of incising the bladder member 15. If desired, the portion of the exterior of the bladder member 15 that is exposed to the cutting element 17 may carry a protective cover (not shown) to further guard against the bladder member 15 being incised by the cutting element 17. The cutting element 17 may be carried at a predetermined spacing from the bladder surface or directly on the surface. When carried on the surface the cutting element 17 may be an integral part of the surface or attached to the surface. If desired the cutting element 17 may be extended/retracted manually via the

- 15 -

connector into/out of the catheter body 13.

For use in urethral dilatation the distal end of the assembly 10 includes an automatic tip 27. Such structure may not be necessary or desirable for dilating other conduits/orifices. For urethral dilation, the assembly 10 may optionally include another lumen and "Foley" type balloon (not shown) distally of the dilatation bladder member 15 to anchor the catheter in the bladder neck of the human body to facilitate correct positioning of the dilatation bladder member 15 and minimize the possibility of migration and displacement of the assembly 10.

One or more of the catheter assembly components may be made of radiopaque materials to facilitate the visualization of the assembly 10 by the physician during placement of the assembly 10 in the body vessel/conduit.

A typical surgical procedure in which the catheter assembly 10 is employed involves the following steps. A cytoscope is first inserted into the vessel/conduit/orifice to be dilated. Calibration devices may be inserted through the cytoscope to facilitate measuring the extent of the vessel/conduit/orifice being dilated. The dilatation catheter of Figure 1 is then inserted to the desired depth in the vessel/conduit. A cytoscope lens may then be inserted to allow visualization of the catheter and the bladder location. Fluid may be infused through the drainage tube or cytoscope to facilitate such visualization. Once in position, the bladder member 15 is inflated. Such inflation causes the cutting element 17 to move radially outwardly as the bladder surface expands radially until the cutting element 17 contacts the surrounding

- 16 -

tissue. In accordance with a preferred embodiment of the invention the bladder member 15 is inextensible as mentioned previously.

As used herein the term "tissue" is intended to include, without limitation, normal tissue, stomatic tissue, neoplastic tissue (tumors) or an obstruction such as plaque. Continued radial expansion of the bladder member 15 positions the cutting element 17 and causes the bladder member 15 to exert pressure on the tissue thereby subjecting the tissue to a substantially uniform tangential tension. If the preferred radio frequency cutting element 17 is utilized a radio frequency current is passed through it. This combined cutting and dilating action results in the tissue being expanded without being torn due to a buildup of excess stresses within the tissue. Instead, the tissue is cut in a clean, concentrated, generally longitudinal fashion by the cutting element 17 and the dilatation does not uncontrollably tear the tissue and cause excessive trauma and bleeding. The inflated bladder member 15 provides the additional benefit of acting as a tamponade to reduce bleeding. The radio frequency cutting element 17 is such that it incises the surrounding tissue in a manner such as to cause controlled incising under the combined cutting and dilating action.

After the vessel/conduit/orifice tissue is incised and dilated and the blockage/obstruction is relieved, the power through the radio frequency cutting element 17 is disconnected, if such a cutting element is used, the bladder member 15 is deflated by connecting the inflation/deflation port 19 to suction or atmospheric pressure and opening the inflation/deflation port valve 20

- 17 -

thereto. Deflation of the bladder member 15 results in a simultaneously radial retraction of the cutting element 17 out of contact with the tissue. Once the bladder member 15 is deflated the cutting element 17 may be retracted via the connector 25. If desired, the cutting element 17 may be retracted prior to complete deflation of the bladder member 15 and/or the bladder member 15 reinflated and left in place to act as a tamponade. Often it is desirable to leave the cutting element 17 in contact with the wound for a time, for example from about 10 minutes to about 2 hours, until the bleeding stops or is under control, and then to deflate the bladder member 15 and withdraw the catheter. Alternatively, the catheter can simply be withdrawn from the vessel/conduit altogether. The particular details of operation are determined by the surgeon depending upon the particular procedure being carried out and the particular person being operated upon.

Figures 3-6 depict another dilatation catheter assembly of the invention, generally designated 29, in use. Only the distal end of the assembly 29 is shown. Adapter(s), inflation/deflation ports are not shown for convenience. The distal end is defined by a closed end catheter tube 32 which carries an inflatable, preferably inextensible, bladder member 33 on its exterior. The lumen 34 of the tube 32 is connected to the source of inflation fluid/suction, as the case may be. The tube 32 has a radial aperture 35 that opens into the lumen 36 of the bladder member 33. A pair of expandable ring-shaped members 37,38 extend around the exterior of the bladder member 33 near the distal

- 18 -

and proximal ends thereof. One or more cutting elements 39 are affixed between the rings so that they extend longitudinally and outwardly therefrom.

5 Figures 3 (in solid line) and 4 show the assembly 29 in its deflated state positioned within a vessel 42 partially obstructed by an obstruction 43. In order to inflate the bladder member 33, pressurized fluid is passed through
10 catheter tube lumen 34 and aperture 35 into the bladder lumen. Inflation of the bladder member 33 in turn causes the ring members 37,38 to expand and move the cutting element(s) 39 radially outward. Figures 3 (phantom line), 5, and 6 show
15 the bladder member 33 in an inflated state with the cutting element 39 incising the obstruction.

 Figure 7 shows yet another dilatation catheter assembly, generally designated 46, of the invention. The assembly 46 is shown in its
20 deflated state. This assembly 46 is similar in structure to assembly 29 except that the assembly 46 is housed within a sheath or introducer 47 and a cauterizing element 48 is connected to the cutting element 39. The sheath permits the
25 assembly 46 to be introduced into the vessel in an unexposed manner, ejected from the end thereof for use, and retracted back into the sheath 47 after use. The ejection and retraction may be achieved by relative longitudinal movement of the sheath
30 47, assembly 46, or both. The cutting element 39 can be a radio frequency cutting element and cauterization will result along with the cutting. Also, following cutting a coagulation producing radio frequency signal can be passed through
35 cutting element 39.

- 19 -

Figure 8 illustrates an embodiment of the invention wherein the cutting element 17 can be advanced beyond the supporting surface of the bladder 15. In the embodiment of Figure 8 the cutting element 17 has an actuator 55 attached to it in the area of the adapter 11, the actuator extending through the adapter 11. After incision has been completed using the bladder 15, that is, after the bladder 15 has been fully extended and the cutting element 17 has cut as deeply as it will when supported by the bladder 15, the surgeon can electively advance the actuator 55, thereby advancing the cutting element 17 and causing it to bow outwardly and away from the bladder 15 and, when a radio frequency current is passed through it, incise further into the tissue a desired distance.

Industrial Applicability

The present invention provides an apparatus and method for controlled surgical dilation and incision within body conduits, vessels and orifices which virtually eliminates tearing and trauma caused by dilation beyond the strength of the tissue forming the body conduit, vessel or orifice being dilated.

While the invention has been described in connection with specific embodiments thereof, it will be understood that it is capable of further modification, and this application is intended to cover any variations, uses, or adaptations of the invention following, in general, the principles of the invention and including such departures from the present disclosure as come within known or

- 20 -

customary practice in the art to which the invention pertains and as may be applied to the essential features hereinbefore set forth, and as fall within the scope of the invention and the limits of the appended claims.

5

CLAIMS

1. A dilatation catheter assembly comprising in combination:

5 a tubular body disposed on an elongate axis and having a distal end carrying a generally cylindrical radially dilatable inextensible member adapted to be positioned longitudinally in a body conduit and to dilate in a generally radially symmetrical manner and exert pressure on surrounding body tissue to provide a substantially uniform tangential tension therein;

means for dilating the dilatable member to a fixed volume and shape; and

10 a cutting element generally parallel to and carried on the exterior of the dilatable member that moves radially in concert with the exterior of the dilatable member and that is adapted to incise said tissue, thereby reducing damage to said tissue from dilation forces.

2. An assembly as recited in Claim 1 wherein the cutting element is responsive to a radio frequency electrical signal to incise said tissue.

3. The assembly recited in Claim 1 wherein the cutting element is disposed in a plane including the elongate axis.

4. The assembly of Claims 1, 2, or 3 wherein the dilatable member is an inflatable bladder that is adapted to be connected to a source of inflation fluid.

5. The assembly of Claim 4 wherein the cutting element is permanently affixed to the exterior surface of the inflatable bladder.

- 22 -

6. The assembly of Claim 4, wherein the cutting element is removably carried on the exterior of the inflatable bladder.

7. The assembly of Claim 4 wherein the cutting element is an integral component of the dilatable member.

8. The assembly of Claim 4 wherein the cutting element comprises a thin wire.

9. The assembly of Claim 4 further comprising an open ended sheath in which the tubular body is housed and from which the tubular body may be retracted after use.

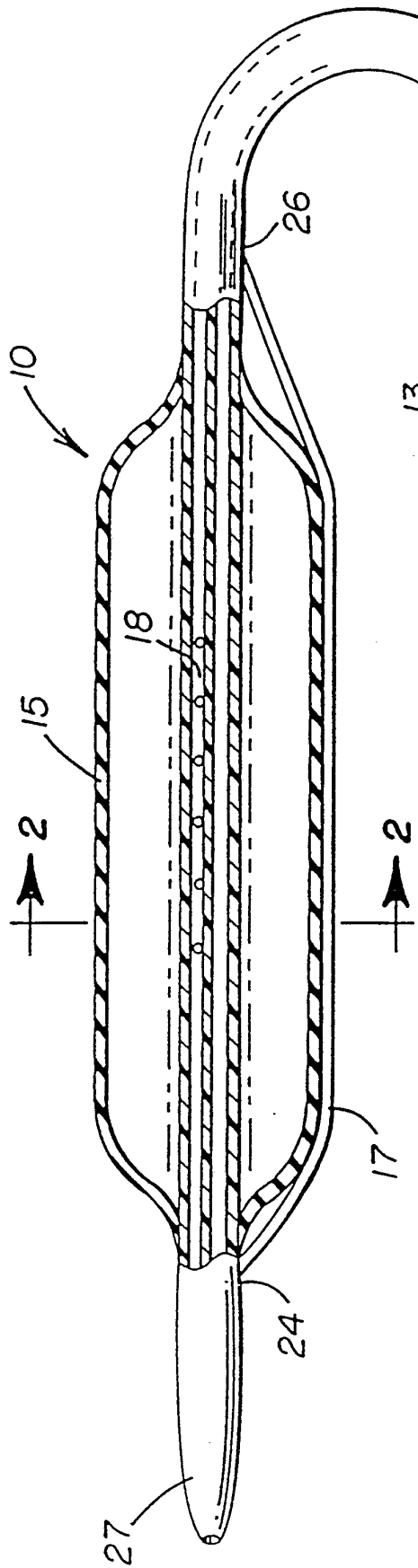

FIGURE 1

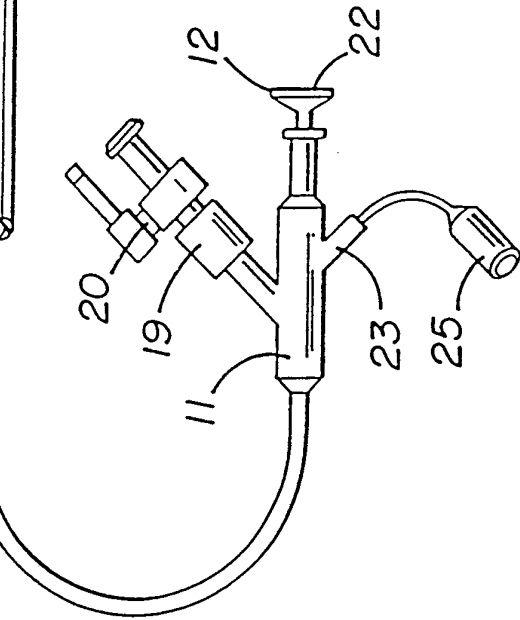

FIGURE 2

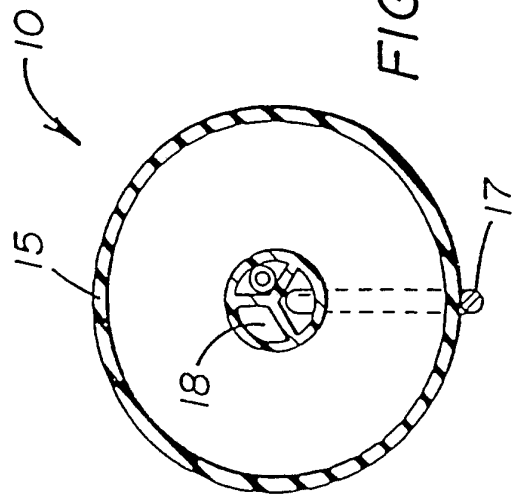

FIGURE 3

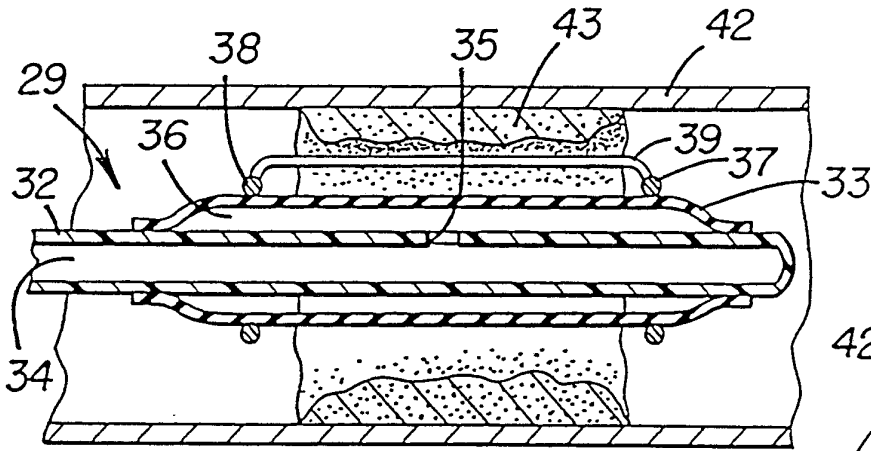
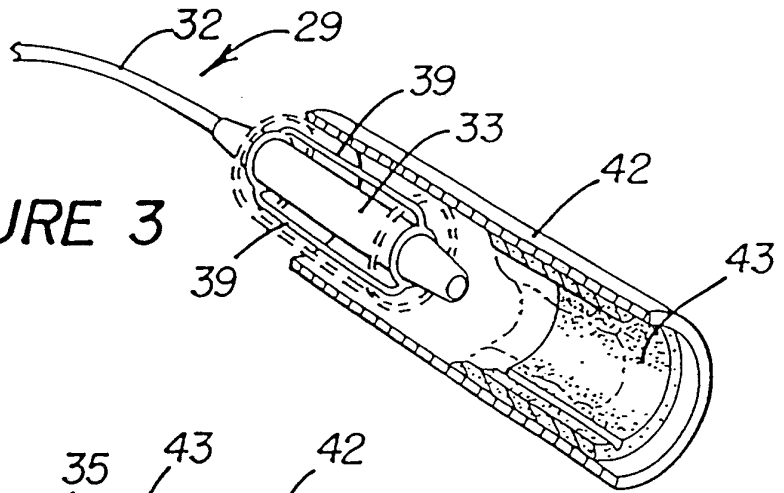

FIGURE 4

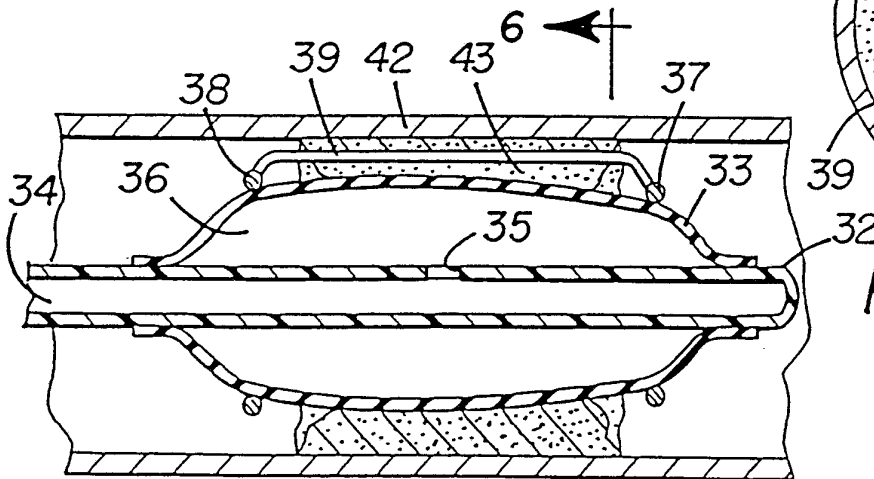

FIGURE 5

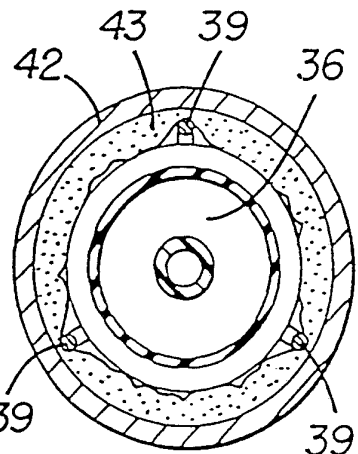

FIGURE 6

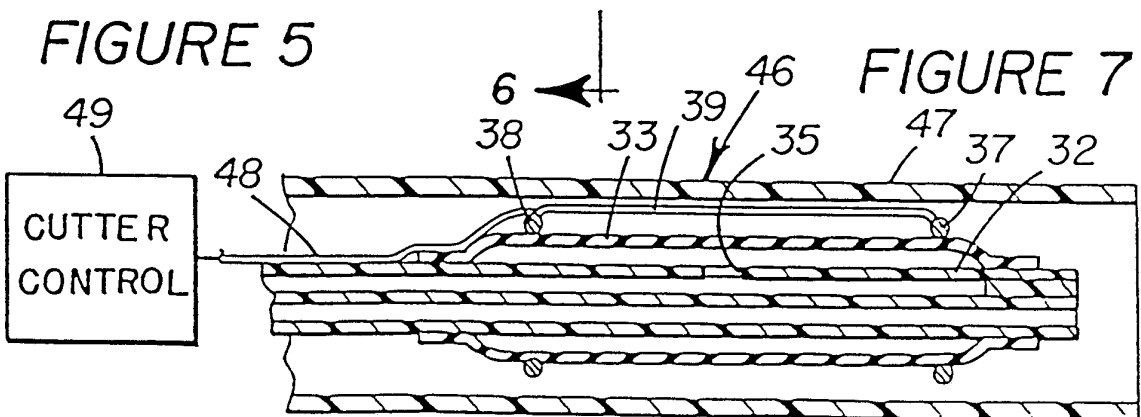

FIGURE 7

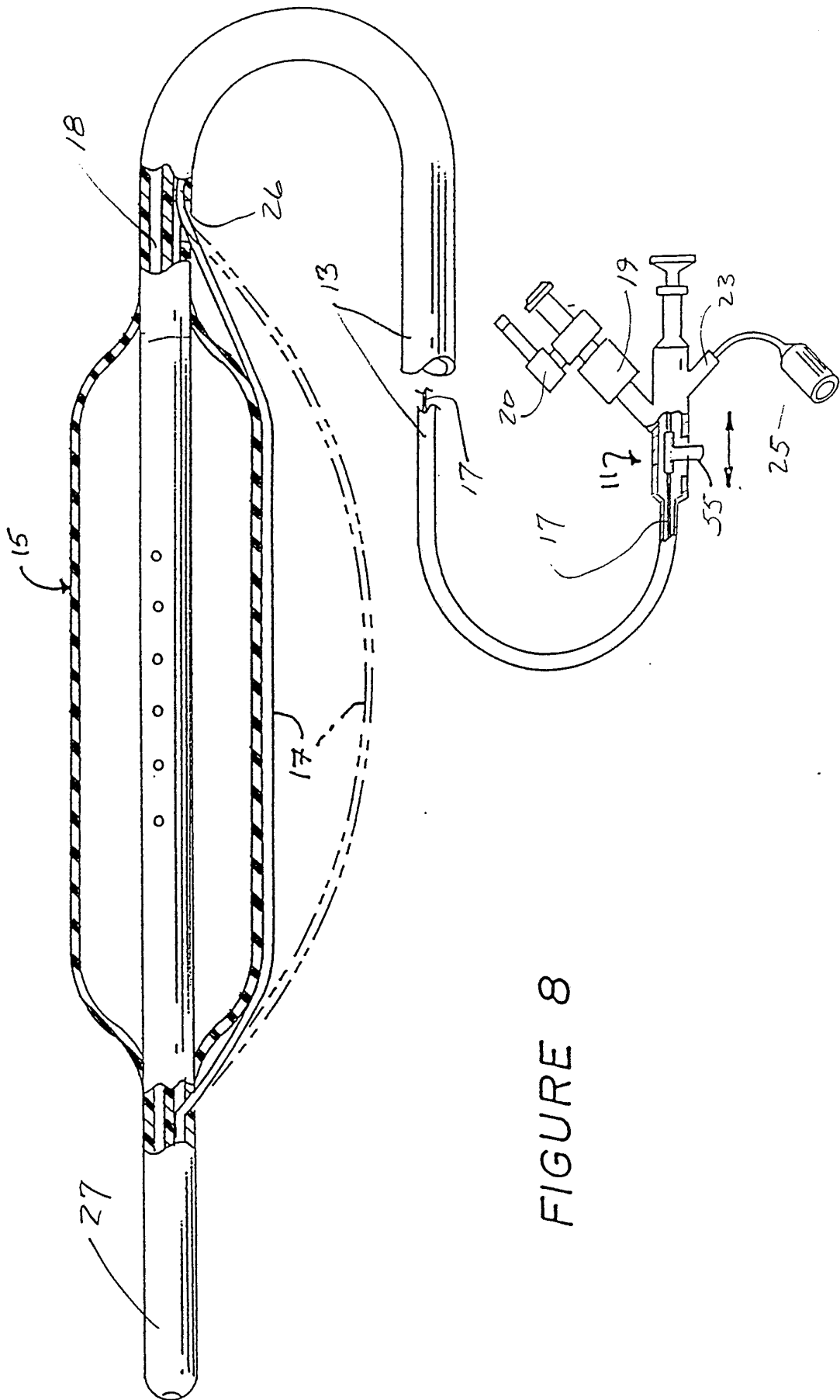

FIGURE 8

INTERNATIONAL SEARCH REPORT

International Application No. PCT/US91/02857

I. CLASSIFICATION OF SUBJECT MATTER (If several classification symbols apply, indicate all) ⁶

According to International Patent Classification (IPC) or to both National Classification and IPC

IPC(5): A61B 17/32, A61M 29/02
U.S. CL. 606/45,159

II. FIELDS SEARCHED

Minimum Documentation Searched ⁷

Classification System	Classification Symbols
U.S.	606/45,159,7,28; 604/22

Documentation Searched other than Minimum Documentation
to the Extent that such Documents are Included in the Fields Searched ⁸

III. DOCUMENTS CONSIDERED TO BE RELEVANT ⁹

Category [*]	Citation of Document, ¹¹ with indication, where appropriate, of the relevant passages ¹²	Relevant to Claim No. ¹³
Y	US, A, 4,799,479 (SPEARS) 24 JANUARY 1989 See entire document	1-9
Y	US, A, 4,273,128 (LARY) 16 JUNE 1981 See entire document	9

^{*} Special categories of cited documents: ¹⁰

"A" document defining the general state of the art which is not considered to be of particular relevance

"E" earlier document but published on or after the international filing date

"L" document which may throw doubts on priority claim(s) or which is cited to establish the publication date of another citation or other special reason (as specified)

"O" document referring to an oral disclosure, use, exhibition or other means

"P" document published prior to the international filing date but later than the priority date claimed

"T" later document published after the international filing date or priority date and not in conflict with the application but cited to understand the principle or theory underlying the invention

"X" document of particular relevance; the claimed invention cannot be considered novel or cannot be considered to involve an inventive step

"Y" document of particular relevance; the claimed invention cannot be considered to involve an inventive step when the document is combined with one or more other such documents, such combination being obvious to a person skilled in the art.

"&" document member of the same patent family

IV. CERTIFICATION

Date of the Actual Completion of the International Search

02 JULY 1991

Date of Mailing of this International Search Report

07 AUG 1991

International Searching Authority

ISA/US

Signature of Authorized Officer

Andreas Robinson
MICHAEL THALER