



US00D542195S

(12) **United States Design Patent**
Golden et al.

(10) **Patent No.:** **US D542,195 S**

(45) **Date of Patent:** **** May 8, 2007**

(54) **VEHICLE LOWER REAR BUMPER**

(75) Inventors: **Edward Golden**, Pinckney, MI (US);
Darrell Behmer, Novi, MI (US);
Melvin Betancourt, Shelby Township,
MI (US); **Solomon Song**, Farmington
Hills, MI (US); **Shawn Wehrly**, Royal
Oak, MI (US)

(73) Assignee: **Ford Global Technologies, LLC**,
Dearborn, MI (US)

(**) Term: **14 Years**

(21) Appl. No.: **29/241,538**

(22) Filed: **Oct. 27, 2005**

(51) **LOC (8) Cl.** **12-16**

(52) **U.S. Cl.** **D12/169**

(58) **Field of Classification Search** D12/90-92,
D12/86, 169, 196; 296/180.1, 180.2; 293/102,
293/113, 115, 117, 120

See application file for complete search history.

(56) **References Cited**

U.S. PATENT DOCUMENTS

D497,579 S * 10/2004 Metros et al. D12/169
D503,135 S * 3/2005 Metros et al. D12/169
D508,880 S * 8/2005 Minami D12/169

OTHER PUBLICATIONS

Car and Driver.com, Auto Show: *2004 North American International Auto Show*, Jan. 2004, http://www.caranddriver.com/article.asp?intAsvPageCurrent=9§ion_id=31&article_id=7671.

Automotive News, Lincoln: *Division searches for styling product mix*, p. 39, Jan. 5, 2004.

LA Car.com, Turning Up the Heat: *Lincoln Aviator*, Jan. 10, 2004 <http://lacar.com/modules.php?name=News&file=print&sid=185>.

AIC Autosite Online, *Cool Concept: Lincoln Aviator Concept*, Apr. 19, 2004 <http://www.aicautosite.com/Previews/concept-lincoln-aviator.asp>.

Automobile Magazine, *50 Sneak Peaks—Lincoln Aviator*, p. 65, May 2004.

Automotive News Online, Future Products—*FORD: Going global: Ford borrows platforms from Europe, Japan*, Aug. 2, 2004 <http://www.autonews.com/article.cms?articleid=49216>.

Popular Mechanics Online, *Spy Reports—Detroit, Asia And Europe*, Feb. 2005 http://www.popularmechanics.com/automotive/spy_reports/1372741.html.

Trailer Life, *Downsizing Lincoln*, vol. 65, Issue 2, ISSN: 00410780, p. 18, Feb. 1, 2005.

The Detroit News, *2007 Lincoln Aviator*, p. 3, Feb. 9, 2005. AutoWeek.com, *2007 Lincoln Aviator*, Feb. 16, 2005 <http://forums.autoweek.com/thread.jspa?forumID=31&threadID=12757&messageID=250387>.

(Continued)

Primary Examiner—Melody N. Brown

(74) *Attorney, Agent, or Firm*—Fredrick Owens

(57) **CLAIM**

The ornamental design for a vehicle lower rear bumper, as shown and described.

DESCRIPTION

FIG. 1 is a front perspective view of a vehicle lower rear bumper attached to a vehicle, no part of the vehicle is claimed;

FIG. 2 is a perspective view of the vehicle lower rear bumper; the broken lines are for illustrative purposes only and form no part of the claimed design;

FIG. 3 is a top plan view of the vehicle lower rear bumper;

FIG. 4 is a left side elevation view of the vehicle lower rear bumper;

FIG. 5 is a right side view is a mirror of the left side view of the vehicle lower rear bumper;

FIG. 6 is bottom plan view of the vehicle lower rear bumper; and,

FIG. 7 is the rear view of the vehicle lower rear bumper.

The broken lines are for illustrative purposes only and form no part of the claimed design.

1 Claim, 7 Drawing Sheets

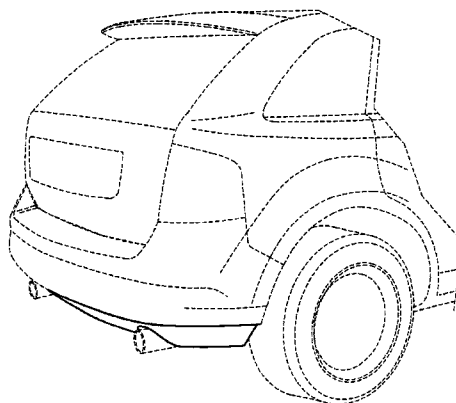

OTHER PUBLICATIONS

TheCarConnection.com, *Future Cars: Ford/PAG/Mazda*,
May 16, 2005 [http://www.thecarconnection.com/Shoppers/
Future_Cars/Ford.S283.A8367.html](http://www.thecarconnection.com/Shoppers/Future_Cars/Ford.S283.A8367.html).

Automobile Magazine, *2006 SUV Sneak Preview*, Publica-
tion Date: Unknown [http://www.automobilemag.com/
2006_sneak_preview/0503_sp_suv/index.html](http://www.automobilemag.com/2006_sneak_preview/0503_sp_suv/index.html).

* cited by examiner

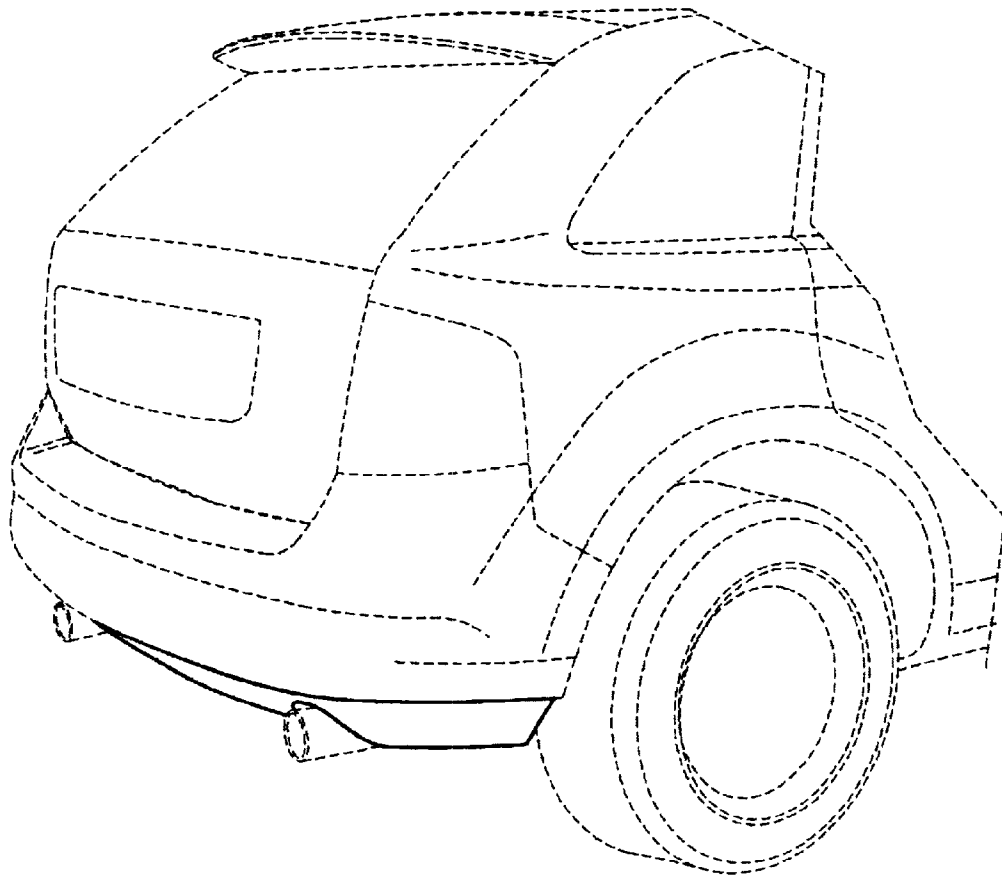

FIG - 1

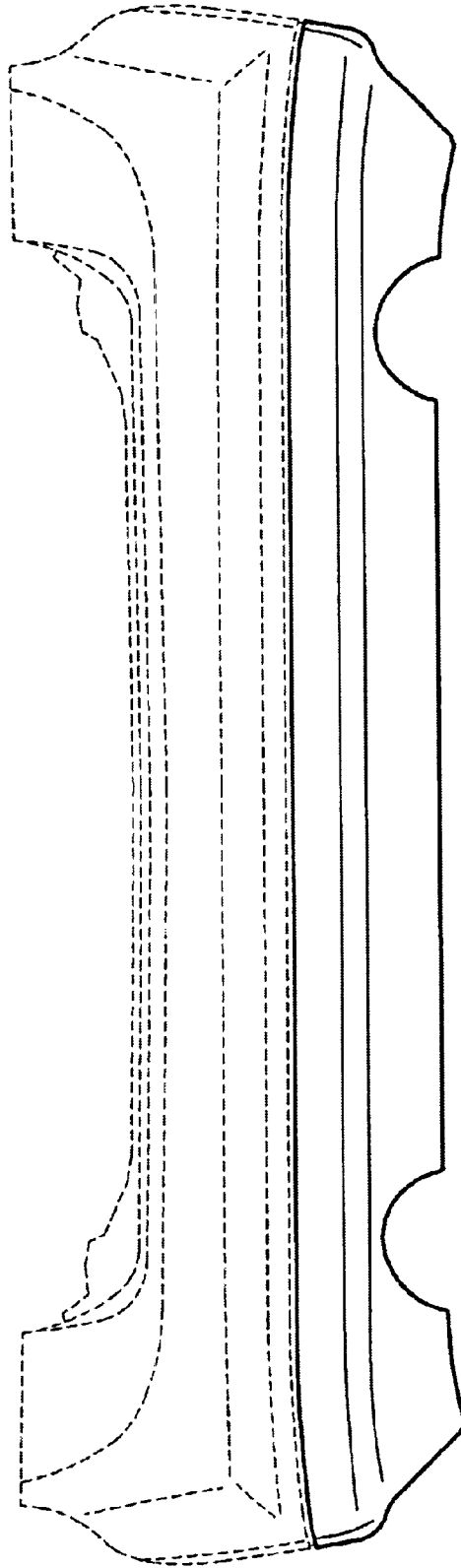

FIG - 2

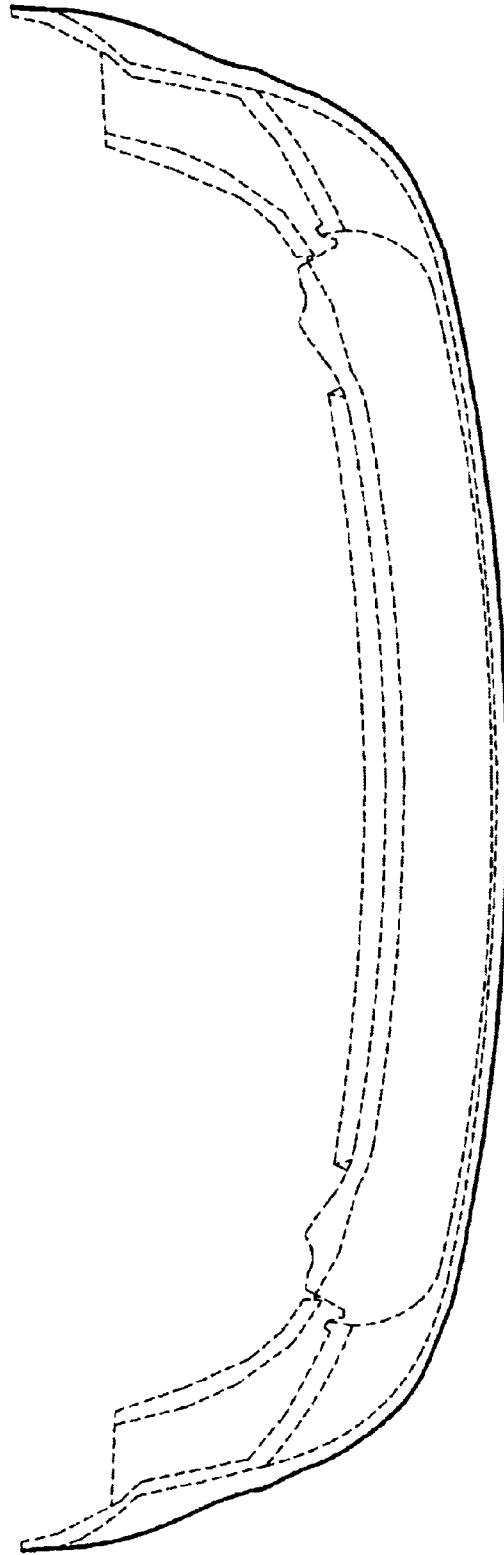

FIG - 3

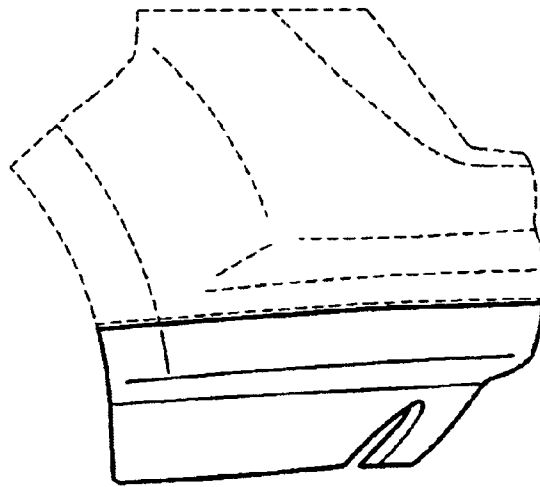

FIG - 4

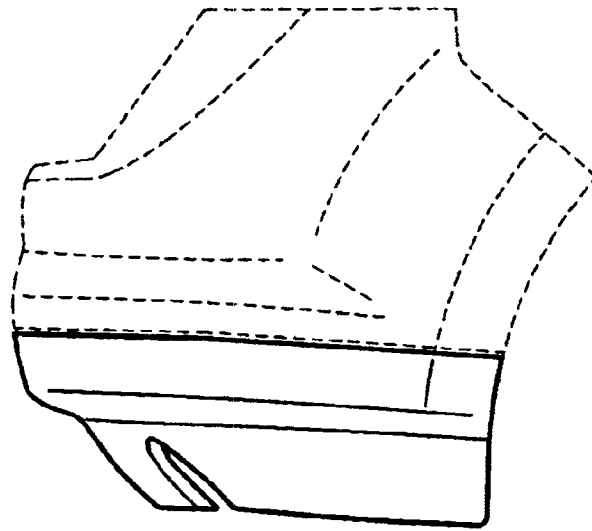

FIG - 5

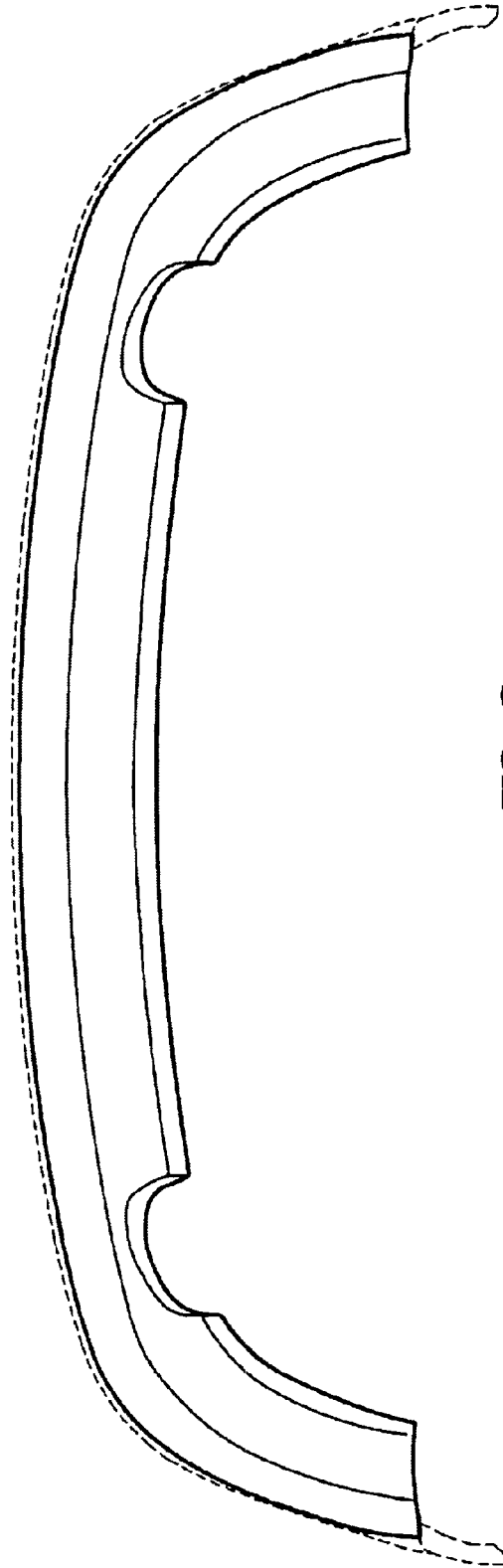

FIG - 6

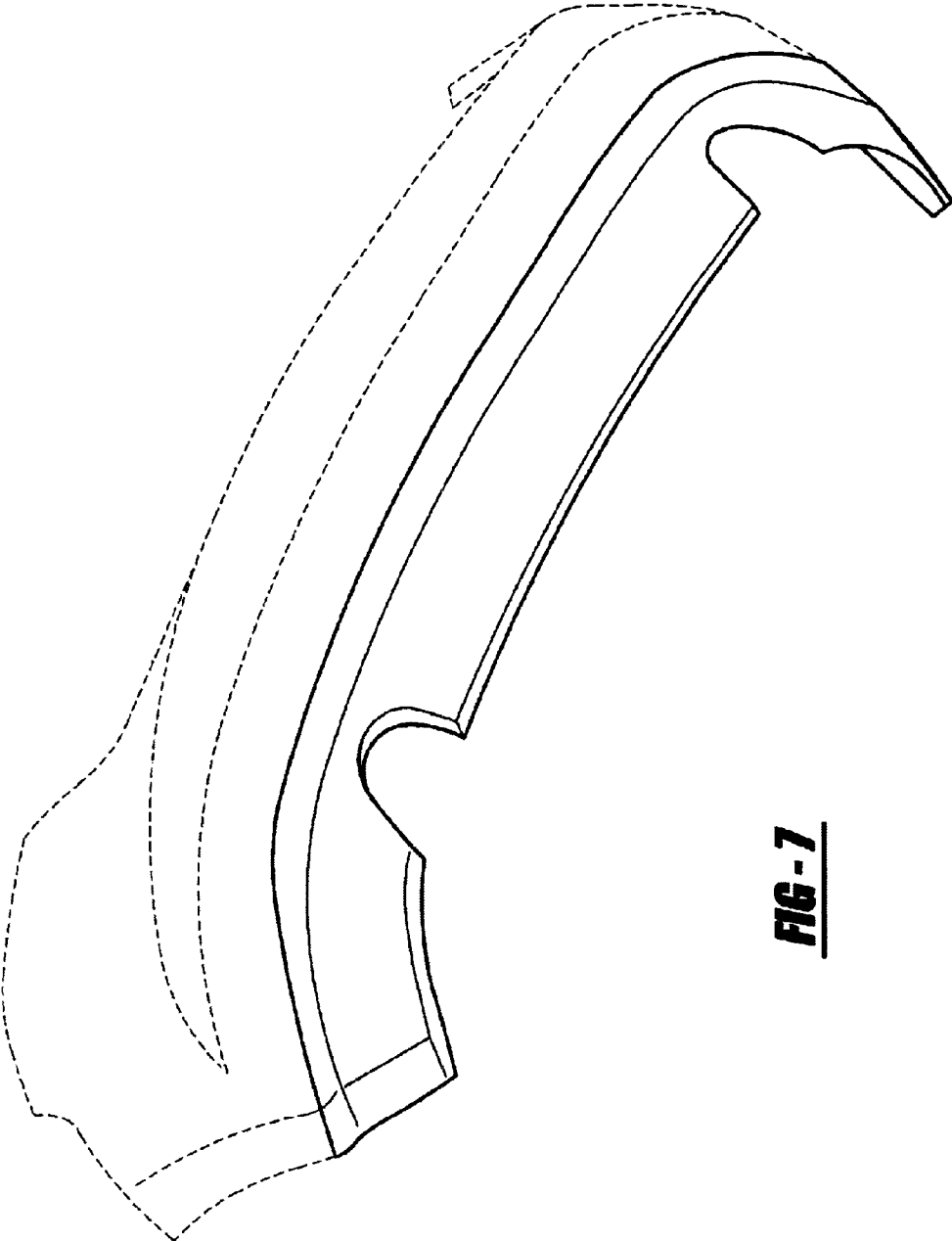

FIG - 7