



US00D843475S

(12) **United States Design Patent** (10) **Patent No.:** **US D843,475 S**
Lesley et al. (45) **Date of Patent:** **** Mar. 19, 2019**

(54) **GAMING MACHINE**

(71) Applicant: **BALLY GAMING, INC.**, Las Vegas, NV (US)

(72) Inventors: **Paul M. Lesley**, Chicago, IL (US);
Larry J. Pacey, Chicago, IL (US);
Walter E. Smolucha, Melrose Park, IL (US)

(73) Assignee: **BALLY GAMING, INC.**, Las Vegas, NV (US)

(**) Term: **15 Years**

(21) Appl. No.: **29/604,749**

(22) Filed: **May 19, 2017**

Related U.S. Application Data

(60) Continuation of application No. 29/563,824, filed on May 9, 2016, now Pat. No. Des. 799,568, which is a continuation of application No. 29/493,014, filed on Jun. 4, 2014, now Pat. No. Des. 742,974, which is a division of application No. 29/452,500, filed on Apr. 17, 2013, now Pat. No. Des. 712,975.

(51) **LOC (11) Cl.** **21-03**

(52) **U.S. Cl.**
USPC **D21/369; D21/385**

(58) **Field of Classification Search**
USPC D21/324-333, 369-370, 385; 273/146; 463/17.2, 42, 46-47; D14/304-309, D14/485-486; 715/781, 786
CPC ... A63F 5/00; A63F 5/04; G07F 17/32; G07F 17/3211; G07F 17/3216; G07F 17/322; G07F 17/3272; G07F 17/3283
See application file for complete search history.

(56) **References Cited**

U.S. PATENT DOCUMENTS

2,661,954 A 12/1953 Koci
D236,720 S 9/1975 Baker
D238,379 S 1/1976 Miller

4,046,419 A 9/1977 Schmitt
D264,485 S 5/1982 Kitchen
4,372,557 A 2/1983 Del Principe et al.
4,373,725 A 2/1983 Ritchie
D275,772 S 10/1984 Akopian et al.
D280,835 S 10/1985 Berge et al.
D280,836 S 10/1985 Ludzia et al.
4,606,545 A 8/1986 Ritchie
4,705,274 A 11/1987 Lubeck
4,840,343 A 6/1989 Gasser
4,861,037 A 8/1989 Oursler
4,960,117 A 10/1990 Moncrief et al.
4,981,298 A 1/1991 Lawlor et al.
D315,110 S 3/1991 Slater
5,015,189 A 5/1991 Wenzinger
5,074,558 A 12/1991 Bleich et al.
5,083,738 A 1/1992 Infanti
5,091,677 A 2/1992 Bleich et al.
5,102,192 A 4/1992 Barile, Sr.
5,110,120 A 5/1992 Smolucha
5,114,112 A 5/1992 Infanti
5,120,058 A 6/1992 Trudeau et al.
5,123,647 A 6/1992 Lawlor et al.
5,143,055 A 9/1992 Eakin
5,149,094 A 9/1992 Tastad
D333,164 S 2/1993 Kraft et al.
5,193,807 A 3/1993 Schilling et al.
5,195,746 A 3/1993 Boyd et al.
D335,150 S 4/1993 Biagi et al.
5,226,653 A 7/1993 Bil et al.
5,232,191 A 8/1993 Infanti
5,290,034 A 3/1994 Hineman
5,297,793 A 3/1994 DeMar et al.
5,316,303 A 5/1994 Trudeau et al.
5,322,283 A 6/1994 Ritchie et al.
5,326,104 A 7/1994 Pease et al.
5,350,174 A 9/1994 Ritchie et al.
D351,869 S 10/1994 Rothschild et al.
5,351,954 A 10/1994 Oursler et al.
5,357,104 A 10/1994 Bleich
5,358,241 A 10/1994 Anghelo et al.
5,358,242 A 10/1994 Trudeau et al.
5,358,243 A 10/1994 Eddy et al.
D352,738 S 11/1994 Anghelo et al.
5,383,663 A 1/1995 Anghelo et al.
5,405,144 A 4/1995 Ritchie et al.
5,409,296 A 4/1995 Barile
5,411,257 A 5/1995 Fulton
5,415,402 A 5/1995 Morrison et al.
5,415,403 A 5/1995 Ritchie et al.
5,417,423 A 5/1995 Oursler et al.
5,417,425 A 5/1995 Blumberg et al.
5,437,453 A 8/1995 Hineman

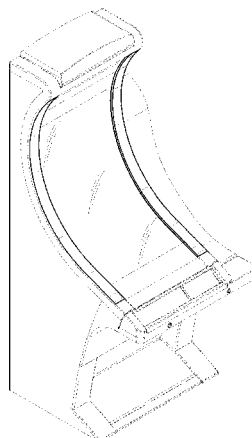

US D843,475 S

Page 2

5,465,963 A	11/1995	Patla, Sr.	6,422,941 B1	7/2002	Thorner et al.
5,472,197 A	12/1995	Gwiasda et al.	6,439,993 B1	8/2002	O'Halloran
5,494,286 A	2/1996	DeMar et al.	D463,504 S	9/2002	Stephan
5,507,488 A	4/1996	Eddy et al.	D464,377 S	10/2002	Wurz et al.
5,511,783 A	4/1996	Popadiuk et al.	D465,813 S	11/2002	Randall
5,516,103 A	5/1996	Lawlor et al.	D466,160 S	11/2002	Hirato et al.
5,522,641 A	6/1996	Infanti	D467,977 S	12/2002	Gatto et al.
5,524,887 A	6/1996	Trudeau et al.	D468,364 S	1/2003	Beadell et al.
5,533,726 A	7/1996	Nordman et al.	6,530,842 B1	3/2003	Wells et al.
5,542,748 A	8/1996	Barile	6,530,872 B2	3/2003	Frehland et al.
D376,391 S	12/1996	Okumura	6,572,187 B2	6/2003	Laufer
5,580,052 A	12/1996	Popadiuk et al.	6,589,114 B2	7/2003	Rose
5,632,482 A	5/1997	Anghelo	6,609,972 B2	8/2003	Seelig et al.
D380,014 S	6/1997	Yang	6,616,142 B2	9/2003	Adams
5,655,965 A	8/1997	Takemoto et al.	6,620,047 B1	9/2003	Alcorn et al.
5,664,777 A	9/1997	Nordman et al.	D481,078 S	10/2003	Stephan
5,669,818 A	9/1997	Thorner et al.	6,646,695 B1	11/2003	Gauselmann
5,678,886 A	10/1997	Infanti	6,652,378 B2	11/2003	Cannon et al.
5,697,612 A	12/1997	Piotrowski et al.	D483,075 S	12/2003	Kang
5,704,835 A	1/1998	Dietz, II	D484,548 S	12/2003	Franco Munoz et al.
5,707,059 A	1/1998	Sullivan et al.	D485,583 S	1/2004	Porto
5,720,480 A	2/1998	Lawlor et al.	6,715,756 B2	4/2004	Inoue
D395,463 S	6/1998	Scott et al.	6,729,618 B1	5/2004	Koenig et al.
5,762,617 A	6/1998	Infanti	D492,363 S	6/2004	Seelig et al.
5,791,731 A	8/1998	Infanti	D492,364 S	6/2004	Seelig et al.
5,806,851 A	9/1998	Gomez et al.	D492,365 S	6/2004	Munoz et al.
5,820,460 A	10/1998	Fulton	D492,676 S	7/2004	Monson et al.
5,833,236 A	11/1998	Oursler et al.	D493,843 S	8/2004	Jackson, Sr. et al.
D405,473 S	2/1999	Tikhonski et al.	D493,846 S	8/2004	Seelig et al.
D407,759 S	4/1999	Isetani et al.	D495,754 S	9/2004	Wurz et al.
D408,366 S	4/1999	Popadiuk	D495,755 S	9/2004	Wurz et al.
5,890,715 A	4/1999	Gomez et al.	D498,267 S	11/2004	Crouch
5,899,454 A	5/1999	Eddy et al.	D500,098 S	12/2004	Doi
5,924,690 A	7/1999	Kopera et al.	6,880,825 B2	4/2005	Seelig et al.
5,934,672 A	8/1999	Sines et al.	D505,162 S	5/2005	Bristol et al.
5,938,195 A	8/1999	Anghelo et al.	D508,268 S	8/2005	Hanchar et al.
5,944,309 A	8/1999	Popadiuk et al.	D508,269 S	8/2005	Wichinsky
D417,145 S	11/1999	McLaughlin	D508,719 S	8/2005	de Haas
5,984,782 A	11/1999	Inoue	D508,961 S	8/2005	Gatto et al.
6,000,697 A	12/1999	Popadiuk et al.	D509,254 S	9/2005	Rasmussen et al.
D419,201 S	1/2000	de Haas	D509,255 S	9/2005	Bristol et al.
D419,606 S	1/2000	Toriyama	D512,105 S	11/2005	Chitrapongse et al.
6,036,188 A	3/2000	Gomez et al.	D513,511 S	1/2006	Decombe
6,047,962 A	4/2000	Popadiuk	D515,144 S	2/2006	Boyd
6,047,963 A	4/2000	Pierce et al.	6,997,810 B2	2/2006	Cole
D424,122 S	5/2000	Dickenson et al.	7,063,615 B2	6/2006	Alcorn et al.
6,071,190 A	6/2000	Weiss et al.	7,108,237 B2	9/2006	Gauselmann
D428,062 S	7/2000	Hayashi	D531,677 S	11/2006	Mallory et al.
6,089,663 A	7/2000	Hill	7,184,277 B2	2/2007	Beime
6,102,394 A	8/2000	Wurz et al.	D539,854 S	4/2007	Luciano et al.
6,113,097 A	9/2000	Krutsch et al.	7,247,098 B1	7/2007	Bradford et al.
6,117,010 A	9/2000	Canterbury et al.	D548,801 S	8/2007	Groswirt
6,120,021 A	9/2000	Piotrowski et al.	D549,785 S	8/2007	Luciano, Jr. et al.
6,129,353 A	10/2000	DeMar et al.	7,267,612 B2	9/2007	Alcorn et al.
6,129,355 A	10/2000	Hahn et al.	D554,710 S	11/2007	Malone et al.
6,135,449 A	10/2000	Cornell et al.	D556,765 S	12/2007	Evans et al.
6,135,562 A	10/2000	Infanti	D557,748 S	12/2007	Jumper
6,149,153 A	11/2000	Sheats, Jr.	D559,328 S	1/2008	Rasmussen et al.
6,155,565 A	12/2000	Gomez et al.	D559,917 S	1/2008	Cole
6,155,925 A	12/2000	Giobbi et al.	D560,724 S	1/2008	Johnson
6,158,737 A	12/2000	Cornell et al.	D560,725 S	1/2008	Johnson
6,159,098 A	12/2000	Slomiany et al.	D563,326 S	3/2008	Patel et al.
6,164,644 A	12/2000	Cornell et al.	D563,481 S	3/2008	Looks et al.
6,173,955 B1	1/2001	Perrie et al.	D564,600 S	3/2008	Greenberg et al.
6,199,861 B1	3/2001	Hume et al.	D564,601 S	3/2008	Strahinic et al.
D439,931 S	4/2001	Yamaguchi	D566,197 S	4/2008	Greenberg et al.
6,210,279 B1	4/2001	Dickinson	D572,314 S	7/2008	Vallejo et al.
6,224,482 B1	5/2001	Bennett	D578,168 S	10/2008	Looks et al.
6,227,614 B1	5/2001	Rubin	D581,983 S	12/2008	Bergstrom
6,227,970 B1	5/2001	Shimizu et al.	RE40,625 E	1/2009	Wurz et al.
D443,313 S	6/2001	Brettschneider	7,479,066 B2	1/2009	Emori
D446,252 S	8/2001	Yamaguchi	D587,272 S	2/2009	Morrow et al.
6,283,546 B1	9/2001	Hill	D587,319 S	2/2009	Moises Deiab
6,290,229 B1	9/2001	Perez	RE40,671 E	3/2009	Wurz et al.
D450,094 S	11/2001	Hedrick et al.	7,503,849 B2	3/2009	Hornik et al.
6,334,612 B1	1/2002	Wurz et al.	D590,025 S	4/2009	Fiore
6,354,660 B1	3/2002	Friedrich	D594,068 S	6/2009	Hsu
D459,402 S	6/2002	Wurz et al.	D599,365 S	9/2009	Brown et al.
6,422,670 B1	7/2002	Hedrick et al.	D599,858 S	9/2009	Lesley et al.

D599,859	S	9/2009	Lesley et al.	2006/0079316	A1	4/2006	Flemming et al.
D599,860	S	9/2009	Lesley et al.	2006/0131810	A1	6/2006	Nicely
D601,638	S	10/2009	Palmisano	2006/0183553	A1	8/2006	Kiriyama et al.
D604,368	S	11/2009	Lesley et al.	2006/0199638	A1	9/2006	Walker et al.
7,628,693	B2	12/2009	Thomas	2006/0281559	A1	12/2006	Luciano
7,666,085	B2	2/2010	Vorias et al.	2006/0287111	A1	12/2006	Mitchell et al.
7,686,689	B2	3/2010	Thomas	2008/0039213	A1	2/2008	Cornell et al.
D613,802	S	4/2010	Meyers et al.	2008/0051202	A1	2/2008	Lube
D615,598	S	5/2010	McComb et al.	2009/0174996	A1	7/2009	Park
7,713,119	B2	5/2010	Pacey et al.	2010/0053231	A1	3/2010	Park
D622,780	S	8/2010	Lesley et al.	2012/0122569	A1	5/2012	Kowolik et al.
D622,781	S	8/2010	Lesley et al.	2012/0168058	A1	7/2012	Kim et al.
D622,782	S	8/2010	Chudek et al.	2013/0180653	A1	7/2013	Kim et al.
D626,182	S	10/2010	Cole et al.	2013/0278875	A1	10/2013	Kim et al.
D626,183	S	10/2010	Cole et al.	2014/0055696	A1	2/2014	Lee et al.
7,811,167	B2	10/2010	Giobbi et al.	2014/0092356	A1	4/2014	Ahn et al.
D631,060	S	1/2011	Flik et al.	2014/0176856	A1	6/2014	Lee et al.
D631,100	S	1/2011	Palmisano	2014/0226111	A1	8/2014	Kim
D633,950	S	3/2011	Terpstra et al.	2014/0226112	A1	8/2014	Kim
D637,238	S	5/2011	O'Keene et al.	2014/0354938	A1	12/2014	Kim
D637,652	S	5/2011	Tahara et al.	2014/0368782	A1	12/2014	Kim et al.
7,938,728	B2	5/2011	Vetter et al.	2014/0375936	A1	12/2014	Park et al.
7,955,176	B2	6/2011	Tastad et al.	2015/0000823	A1	1/2015	Kim et al.
D641,047	S	7/2011	Tahara et al.	2015/0036073	A1	2/2015	Im et al.
7,976,393	B2	7/2011	Haga et al.	2015/0116621	A1	4/2015	Park et al.
7,985,139	B2	7/2011	Lind et al.	2015/0116625	A1	4/2015	Hwang et al.
8,002,424	B2	8/2011	Hwang et al.	2015/0301390	A1	10/2015	Kim
8,002,626	B2	8/2011	Englman				
D646,336	S	10/2011	Kelly et al.				
D646,337	S	10/2011	Kelly et al.				
D646,691	S	10/2011	Thai et al.				
D649,605	S	11/2011	Terpstra et al.				
D651,608	S	1/2012	Allen et al.				
8,152,623	B2	4/2012	Fiden				
8,162,740	B2	4/2012	Aoki				
8,216,061	B2	7/2012	Pacey				
8,267,764	B1	9/2012	Aoki et al.				
D669,076	S	10/2012	Haller				
8,292,451	B2	10/2012	Hwang et al.				
8,303,420	B2	11/2012	Chudek et al.				
8,305,743	B2	11/2012	Wu et al.				
8,323,114	B2	12/2012	Burak et al.				
D673,620	S	1/2013	Johnson et al.				
8,353,755	B2	1/2013	Vann et al.				
8,371,920	B2	2/2013	Gomez et al.				
8,371,927	B2	2/2013	Englman				
8,371,928	B2	2/2013	Englman et al.				
8,376,832	B2	2/2013	O'Connor et al.				
D678,955	S	3/2013	Lesley et al.				
D678,956	S	3/2013	Lesley et al.				
D678,957	S	3/2013	Cesaroni et al.				
D678,958	S	3/2013	Cesaroni et al.				
D681,130	S	4/2013	Lesley et al.				
8,430,756	B2	4/2013	McComb et al.				
D682,948	S	5/2013	Cesaroni et al.				
D685,033	S	6/2013	Wudtke				
D691,665	S	10/2013	Chudek				
D691,666	S	10/2013	Lesley et al.				
D693,343	S	11/2013	Haller				
D704,273	S	5/2014	Chudek				
D704,275	S	5/2014	Lesley et al.				
D706,741	S	6/2014	Myers				
D712,975	S	9/2014	Lesley et al.				
D714,875	S	10/2014	Wudtke et al.				
D715,364	S	10/2014	Wudtke et al.				
8,982,545	B2	3/2015	Kim et al.				
D730,993	S	6/2015	Castro et al.				
D740,888	S	10/2015	DePalma et al.				
D742,974	S	11/2015	Lesley et al.				
D742,975	S	11/2015	Myers et al.				
RE46,169	E	10/2016	Kelly et al.				
2002/0041069	A1	4/2002	Steelman				
2003/0122973	A1	7/2003	Huang				
2004/0018877	A1	1/2004	Tastad et al.				
2004/0029631	A1	2/2004	Duhamel				
2004/0053662	A1	3/2004	Pacey				
2005/0014547	A1	1/2005	Gomez et al.				
2006/0009284	A1	1/2006	Schwartz et al.				
2006/0034042	A1	2/2006	Hisano et al.				

FOREIGN PATENT DOCUMENTS

EP	649 671	A1	4/1995
JP	03210172	B2	9/2001
KR	10-113734		2/2012
KR	10-2012-0051630		5/2012
KR	10-1268471	B1	6/2013
KR	10-1278904	B1	6/2013
KR	10-1336677	B1	12/2013
KR	10-1381609	B1	4/2014
KR	10-1381610	B1	4/2014
KR	10-2015-0013987		2/2015
KR	10-1539221	B1	7/2015
TW	200949775	A	12/2009

OTHER PUBLICATIONS

Product Sheet for "American Eagle," Eagle Co. Ltd., 1997 (2 pages).

Product Sheet for "Monopoly Chairman of the Board™," WMS Gaming Inc., 1999 (2 pages).

Product Sheet for "American Eagle," Eagle Co., Ltd., 2000 (2 pages).

Product Sheet for "Survivor," WMS Gaming Inc., 2001 (4 pages).

Product Sheet for "ProSLOT® 6000," Bally Gaming Systems, 2002 (4 pages).

Product Sheet for "EVO™ Hybrid," Bally Gaming Systems, 2002 (4 pages).

Product Sheet for "3RV™," WMS Gaming Inc., 2002 or earlier (2 pages).

Product Sheet for "Miss America," AC Coin & Slot, 2002 or earlier (2 pages).

Product Catalog for Ainsworth Game Technology Ltd, date estimated as early as 2007 (6 pages).

Product Sheet for "Ultrapin™," Global VR, 2007 (1 page).

Brochure for "Virtual Pinball," Tab-Austria, 2007 (8 pages).

Catalog for Atronic®-Spielo®, date estimated as early as 2008 (2 pages).

Product Catalog for "Alpha Elite™," Bally Technologies, date estimated as early as 2008-2009 (2 pages).

Cabinet Brochure for Hydako Co., date estimated as early as 2009 (1 page).

Product Catalog for Bally Technologies, date estimated as early as 2010 (2 pages).

Fall & Winter Catalog for Aristocrat, date estimated as early as 2010-2011 (7 pages).

Catalog for “Your Partner Innovation,” Bally Technologies, date estimated as early as 2011 (4 pages).

Photonics Industry and Technology Development Association (PIDA); “E-Paper Shows Potential at Creating a Paperless Haven”; OptoLink Magazine, 3 Quarter 2008; pp. 9-11 (4 pages).

AU Optronics Corp.; News Center: “AUO Announces Multiple Upcoming Innovations”; Oct. 27, 2008; retrieved from <<http://www.auo.com/?sn=107&lang=en-US&c=10&n=363>>; (2 pages).

DigiTimes Inc.; “FPD China 2009: AUO 8.9-inch convex display panel”; Mar. 12, 2009; retrieved from <<http://www.digitimes.com/photogallery/showphoto.asp?ID=3376>>; (3 pages).

Gizmodo.com; “AUO Curved Displays, Ultra Thin LCDs on the Way”; May 20, 2008; retrieved from <<http://gizmodo.com/392248/auo-curved-displays-ultra-thin-lcds-on-the-way>>; (2 pages).

PC World; “AU Optronics Shows Off Curved LCD Screen”; May 20, 2008; retrieved from <<http://www.pcworld.com/article/146083/article.amp.html>> (3 pages).

DailyTech; “AUO Shows Off Curved Display and Touch Screen”; May 23, 2008; retrieved from <<http://www.dailytech.com/AUO+Shows+Off+Curved+Display+and+Touch+Screen+Tech/article11845.htm>>; (2 pages).

OLED-Info; “LG Phillips LCD Develops 14.3-Inch Color E-Paper Display”; Jan. 4, 2008; retrieved from <http://www.oled-info.com/lg/lg_phillips_lcd_develops_14_3_inch_color_e_paper_display>; (2 pages).

NewLaunches; “LG Phillips LCD develops world’s highest resolution 14.3-inch flexible color E-paper display!”; Jan. 2, 2008; retrieved from <http://newlaunches.com/archives/lgphillips_lcd_develops_worlds_highest_resolution_143inch_flexible_color_epaper_display.php>; (4 pages).

Wood, M., Major, C., Carr, V. eds.; “Curved Screens: Worth It?” video found at <<https://www.nytimes.com/video/technology/personaltech/10000002788325/curved-screens-worth-it.html>>; New York Times; Mar. 26, 2014.

Immersaview; “Why choose a Curved Screen for your Multi-Projector Setup”; Jan. 28, 2016; retrieved from <<http://www.immersaview.com/resources/why-curved/>> (7 pages).

Denison; “Why can’t you buy a flat OLED yet? The curve isn’t just about viewing experience”; Digital Trends; Aug. 18, 2013; retrieved from <<http://www.digitaltrends.com/home-theater/why-did-the-us-get-stuck-with-curved-oled/#!zXypT>> (8 pages).

Wilcox; “LG, Samsung, and Sony throw TV buyers a curve”; Consumer Reports; Sep. 10, 2013; retrieved from <<http://www.consumerreports.org/cro/news/2013/09/curved-tv-screens/index.htm#>> (1 page).

Snider; “Sony tosses latest pitch for curved TV displays”; USA Today; Oct. 15, 2013; retrieved from <<http://www.usatoday.com/story/tech/personal/2013/10/15/new-curved-sony-led-hdtv/2982051/>> (2 pages).

Morrison; “Curved OLED HDTV screens are a bad idea (for now)”; CNET; Jun. 18, 2013; retrieved from <<https://www.cnet.com/news/curved-oled-hdtv-screens-are-a-bad-idea-for-now/>> (9 pages).

Cochran; “Why Samsung’s curved-screen TV might be a ‘game changer’”; CBS News; Aug. 14, 2013; retrieved from <<http://www.cbsnews.com/news/why-samsungs-curved-screen-tv-might-be-a-game-changer/>> (3 pages).

Kelly; “TV trends at CES: 4K, curves and smart TVs”; CNN; Jan. 8, 2014; retrieved from <<http://www.cnn.com/2014/01/07/tech/gaming-gadgets/ces-television-trends/>> (5 pages).

Manjoo; “TV Makers Are Out of Ideas”; Wall Street Journal; Jan. 8, 2014; retrieved from <<https://www.wsj.com/news/articles/SB10001424052702303393804579308801012230792>> (4 pages).

Daniel; “Curved Monitors—Overview”; Curved Monitor Test; Aug. 28, 2015; retrieved from <<http://www.curved-monitor-test.de/>> (5 pages).

Matthias; “Curved TV—Overview”; Curved TV Test; Apr. 20, 2016; retrieved from <<https://technikblog.net/femseher-test/curved-tv/>> (16 pages, in German).

Ljt216; “Flat Screen vs. Curved CRTs for Retro Games”; Reddit; Jul. 29, 2015; retrieved from <https://www.reddit.com/r/gamecollecting/comments/3f25r0/flat_screen_vs_curved_crts_for_retro_games/> (4 pages).

Co-Pending Design U.S. Appl. No. 29/536,824, filed Aug. 19, 2015.

Co-pending Design U.S. Appl. No. 29/559,629, filed Mar. 30, 2016.

Co-pending Design U.S. Appl. No. 29/559,613, filed Mar. 30, 2016.

Co-pending Design U.S. Appl. No. 29/559,593, filed Mar. 30, 2016.

Primary Examiner — Sandra L Morris

(74) *Attorney, Agent, or Firm* — Banner & Witcoff, Ltd.

(57)

CLAIM

The ornamental design for a gaming machine, as shown and described.

DESCRIPTION

FIG. 1 is a left front perspective view of a gaming machine showing our new design;

FIG. 2 is a right front perspective view thereof;

FIG. 3 is a front view thereof;

FIG. 4 is a top view thereof;

FIG. 5 is a cross-sectional view taken along 5-5 of FIG. 4;

FIG. 6 is a left front perspective view of an alternate embodiment of the gaming machine showing our new design;

FIG. 7 is a right front perspective view thereof;

FIG. 8 is a front view thereof;

FIG. 9 is a top view thereof;

FIG. 10 is a cross-sectional view taken along 10-10 of FIG. 9;

FIG. 11 is a left front perspective view of an alternate embodiment of the gaming machine showing our design;

FIG. 12 is a right front perspective view thereof;

FIG. 13 is a front view thereof;

FIG. 14 is a top view thereof;

FIG. 15 is a cross-sectional view taken along 15-15 of FIG. 14;

FIG. 16 is a left perspective view of an alternate embodiment of the gaming machine showing our new design;

FIG. 17 is a right perspective view thereof;

FIG. 18 is a front view thereof;

FIG. 19 is a top view thereof; and,

FIG. 20 is a cross-sectional view taken along 20-20 of FIG. 19.

The broken line showing of the remainder of the gaming machine illustrates environmental structure and forms no part of the claimed design. The oblique line shading on the curved display depicts a transparent, translucent, highly polished or reflective surface.

1 Claim, 20 Drawing Sheets

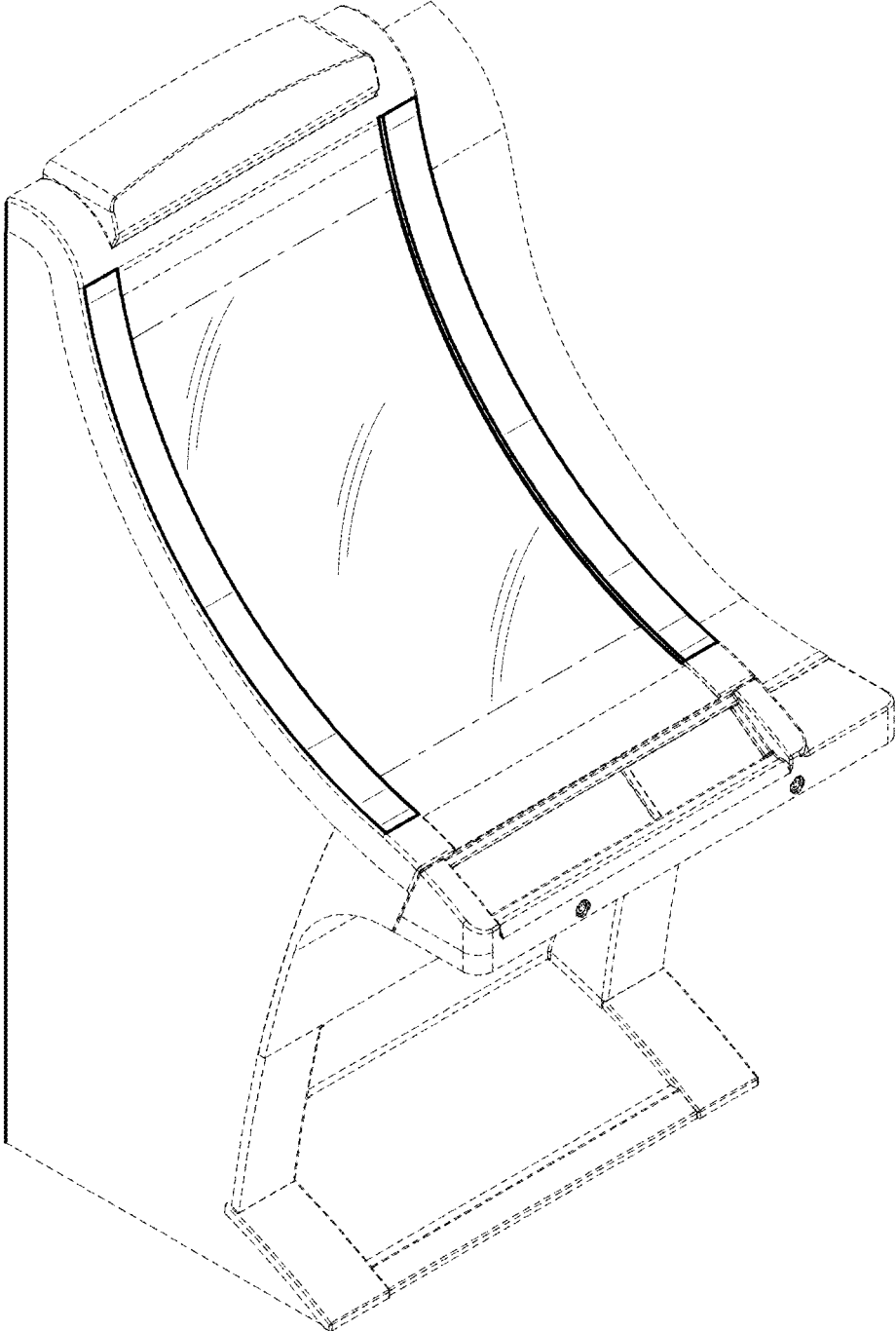

FIG. 1

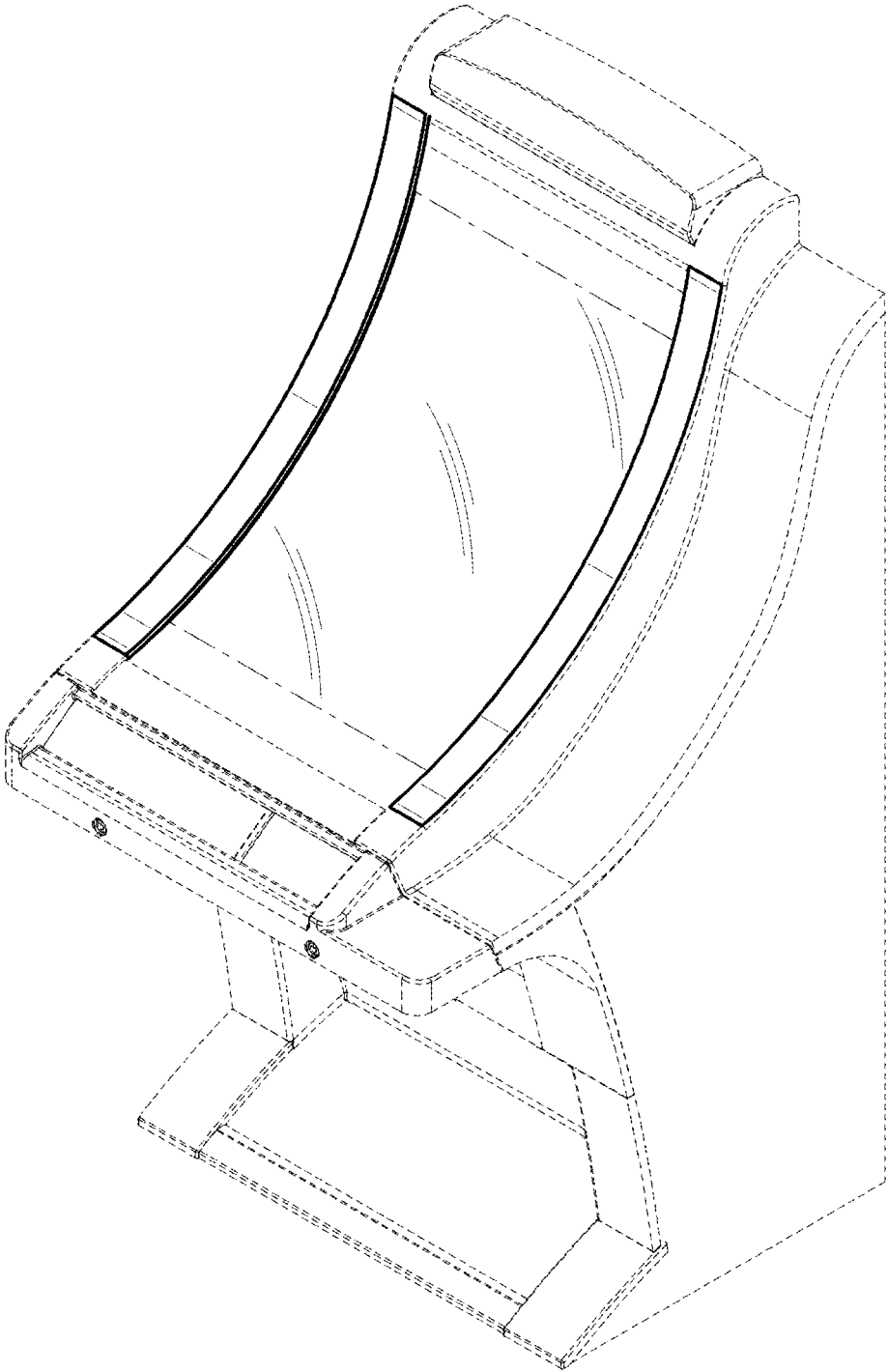

FIG. 2

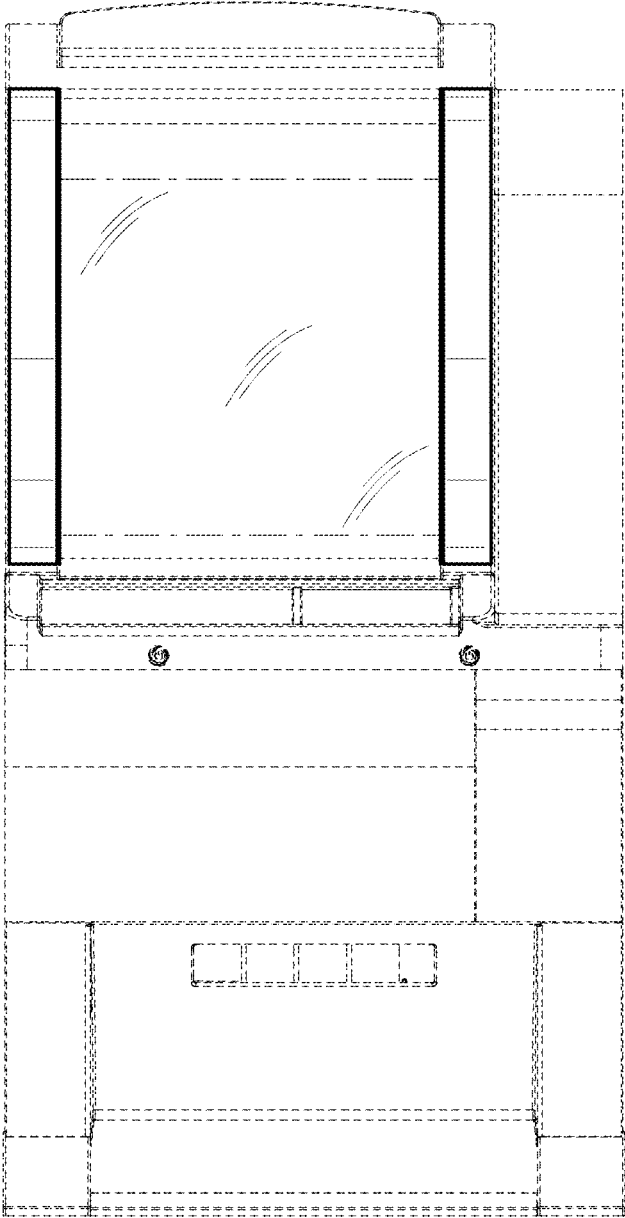

FIG. 3

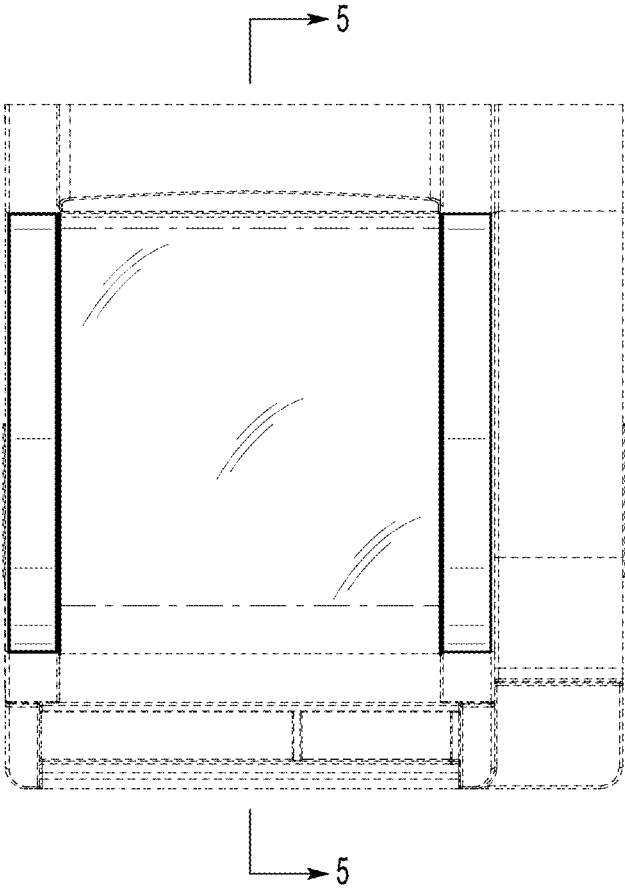

FIG. 4

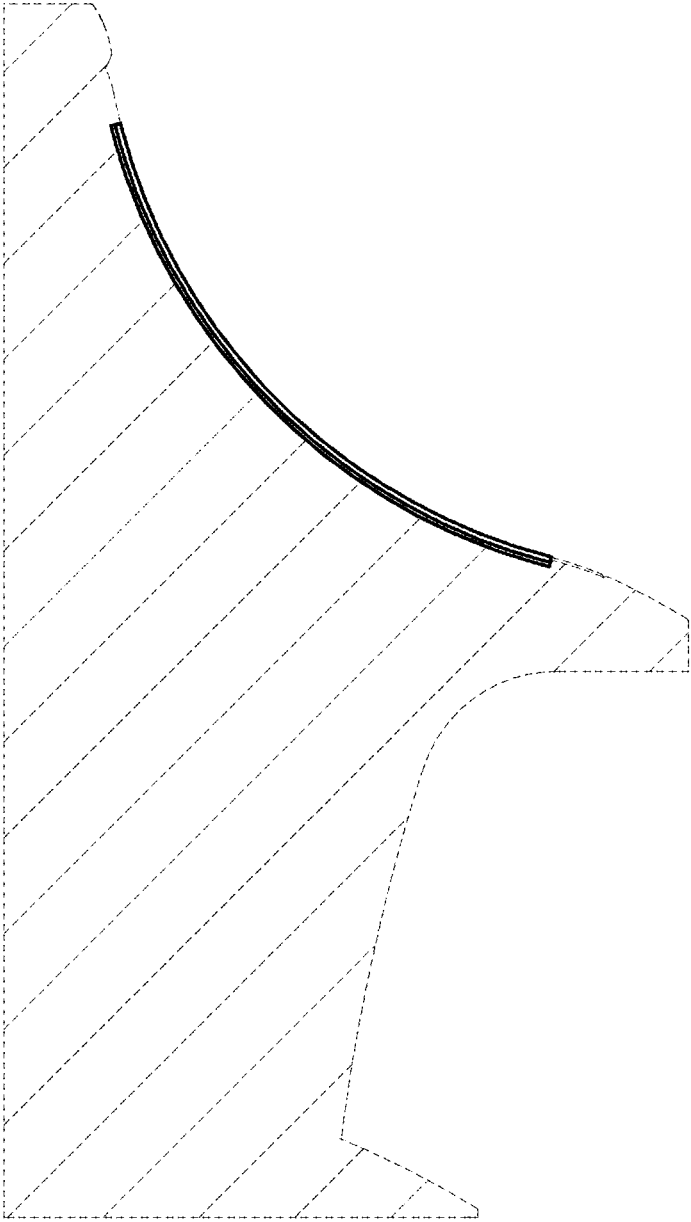

FIG. 5

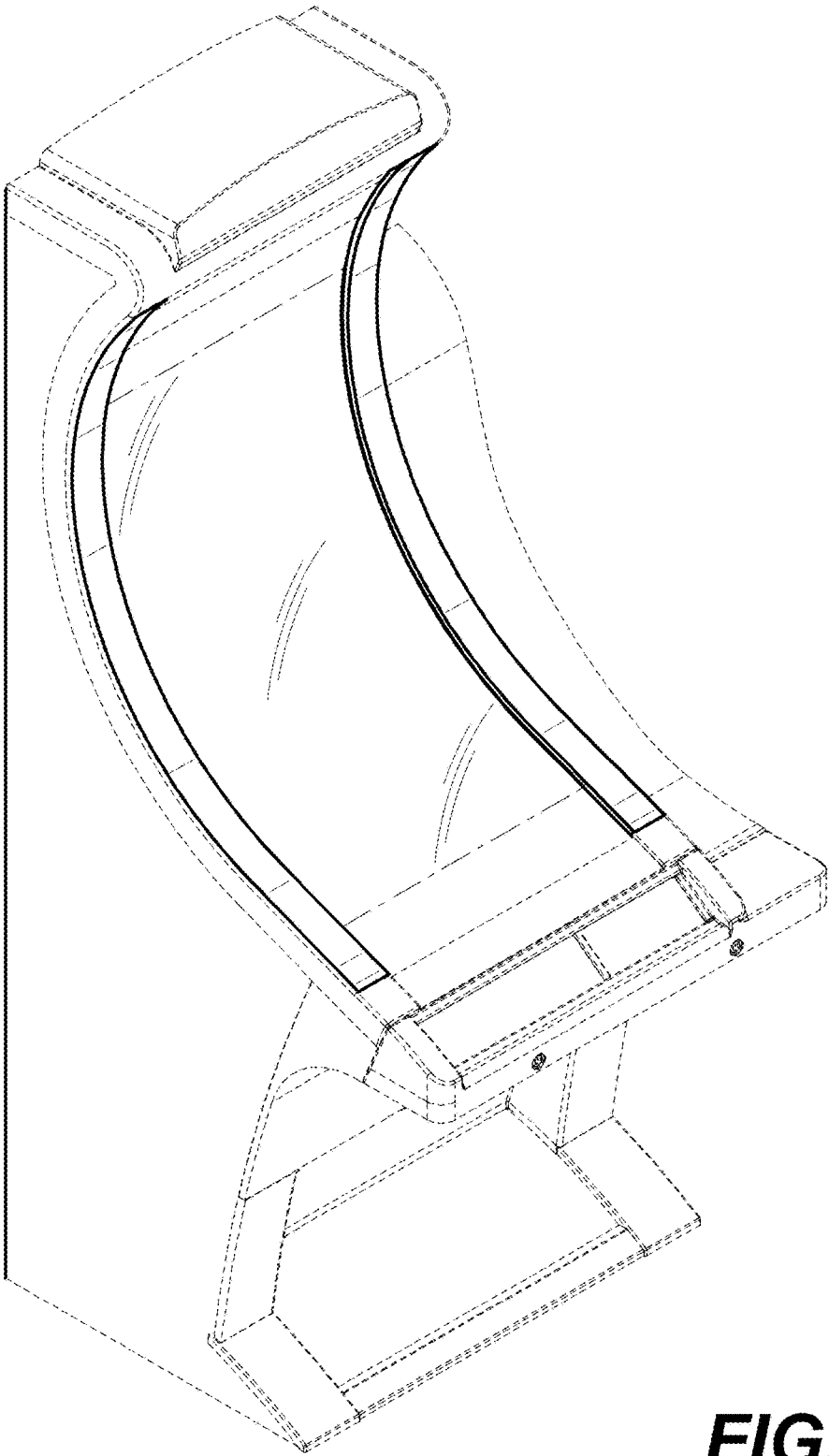

FIG. 6

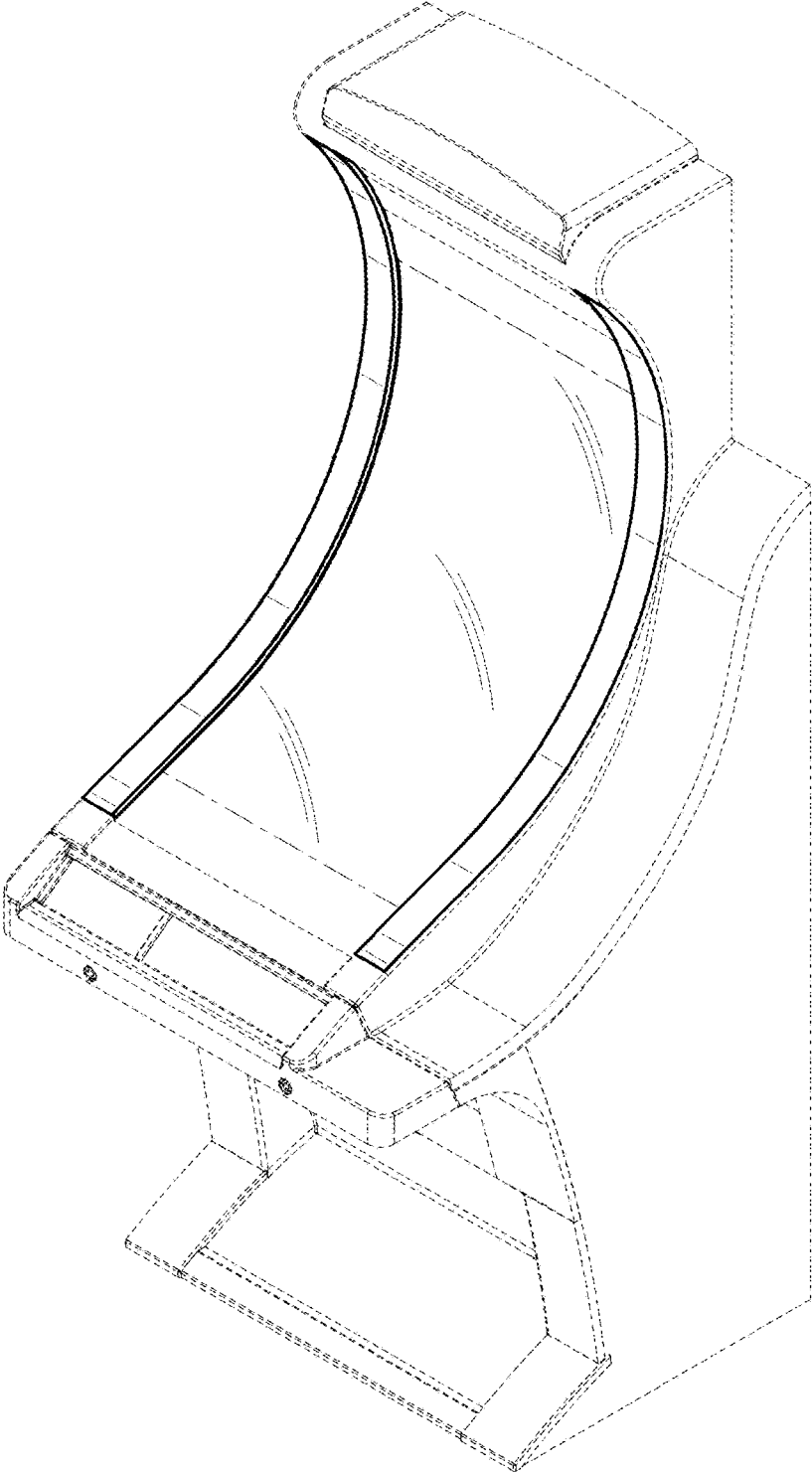

FIG. 7

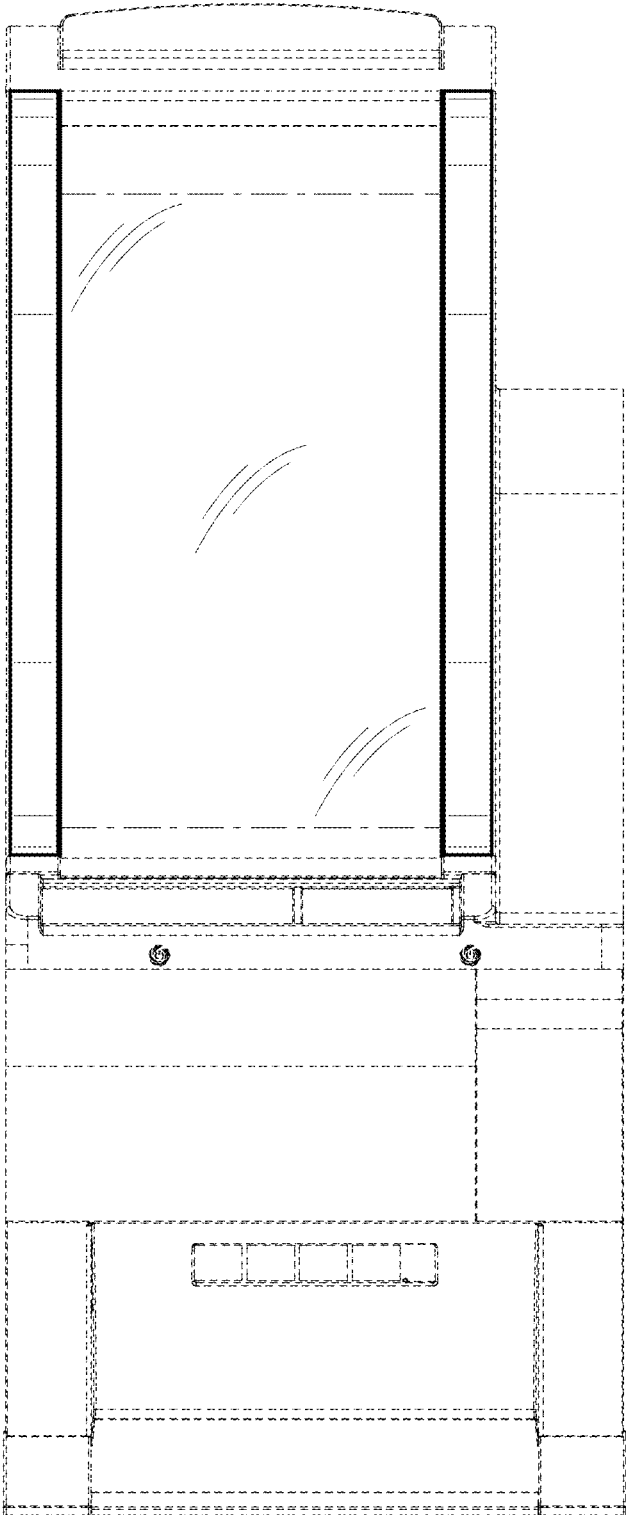

FIG. 8

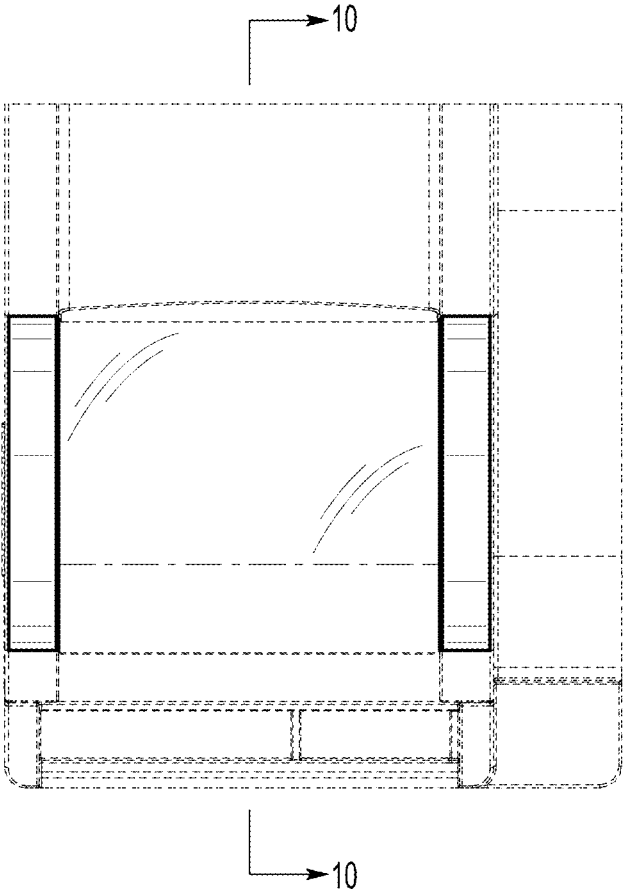

FIG. 9

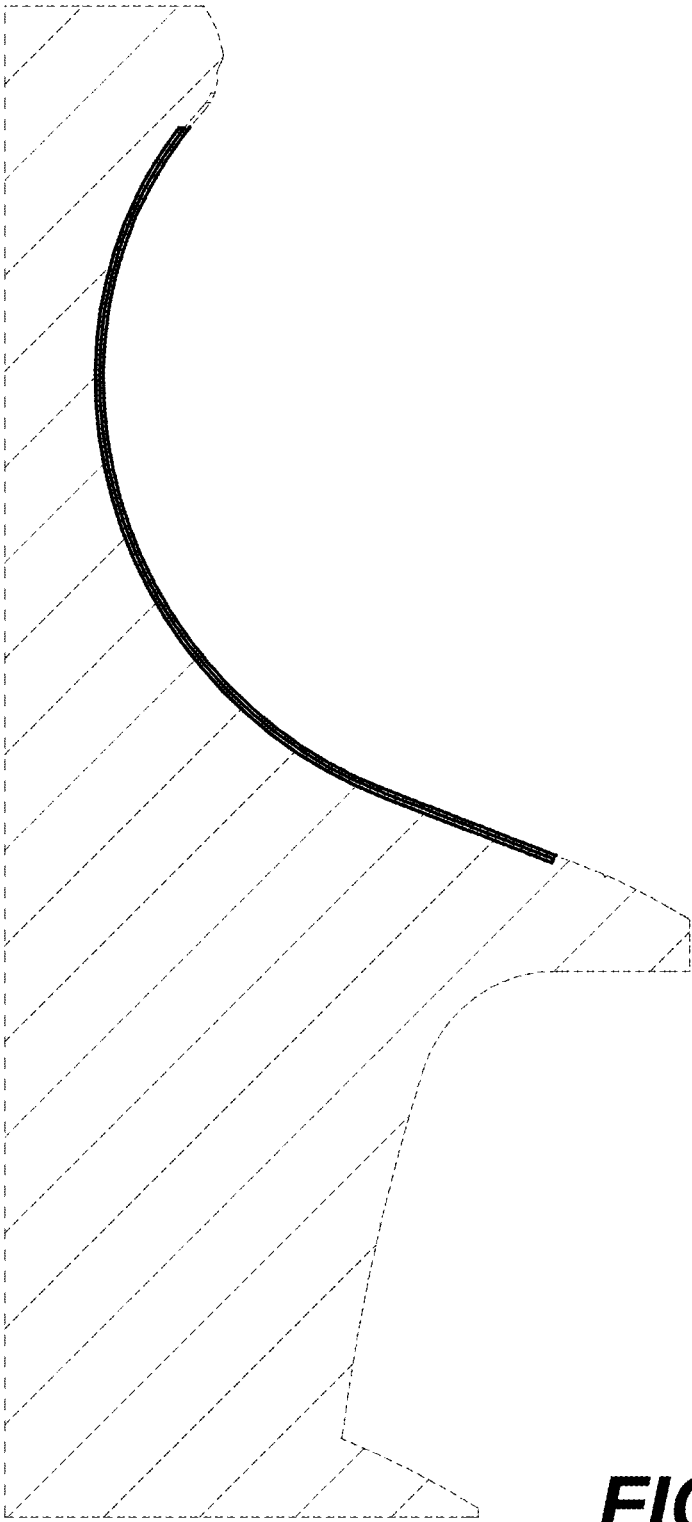

FIG. 10

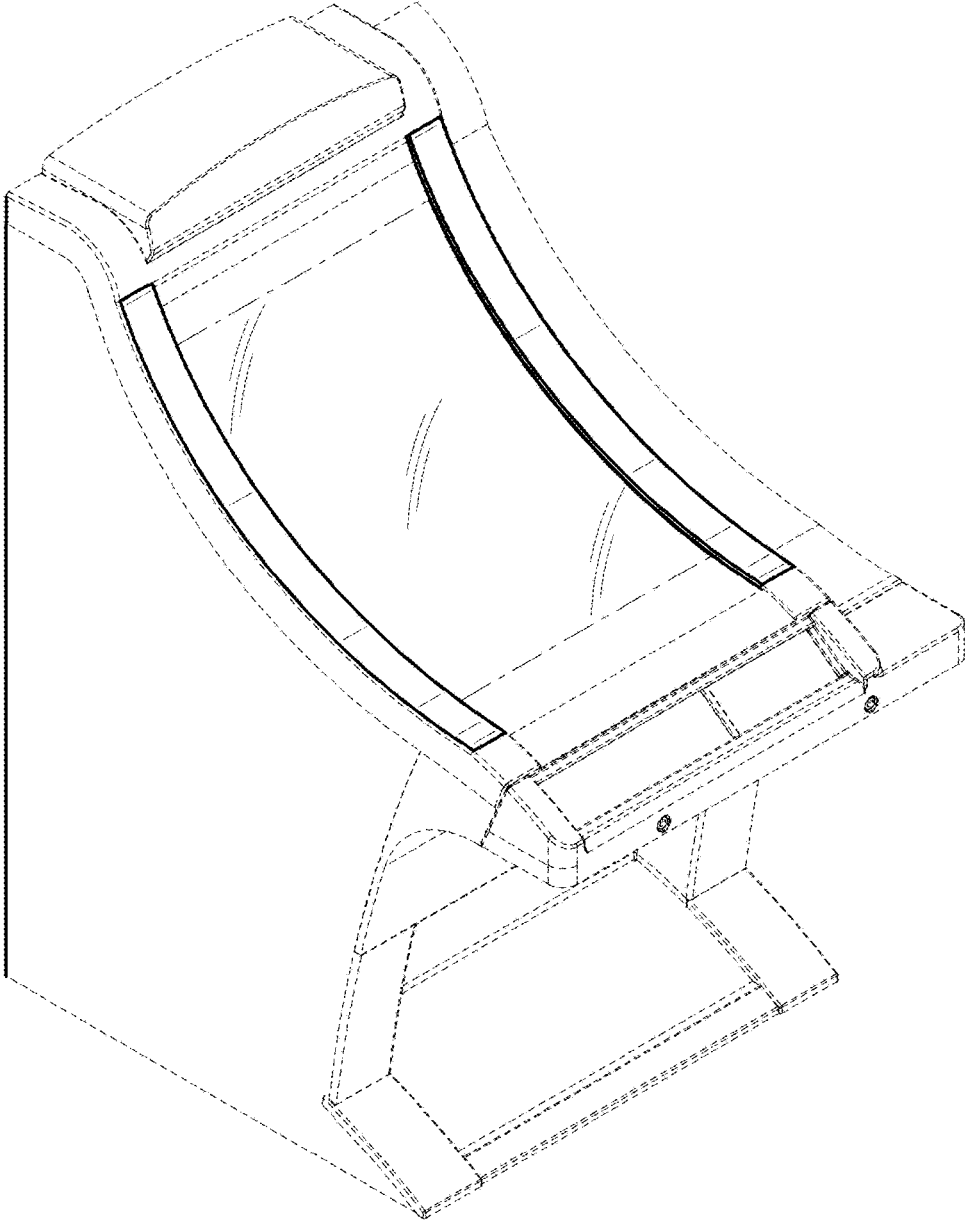

FIG. 11

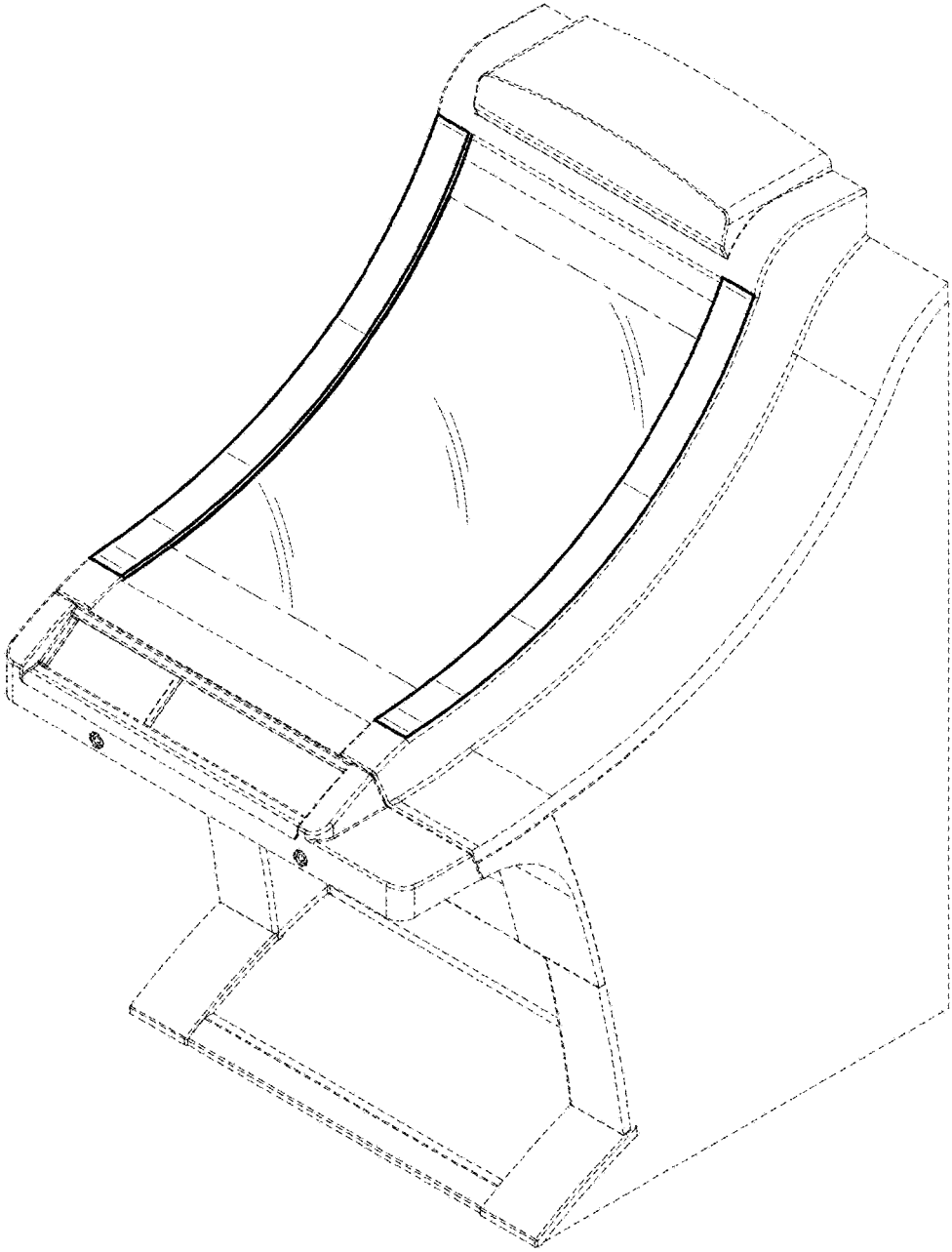

FIG. 12

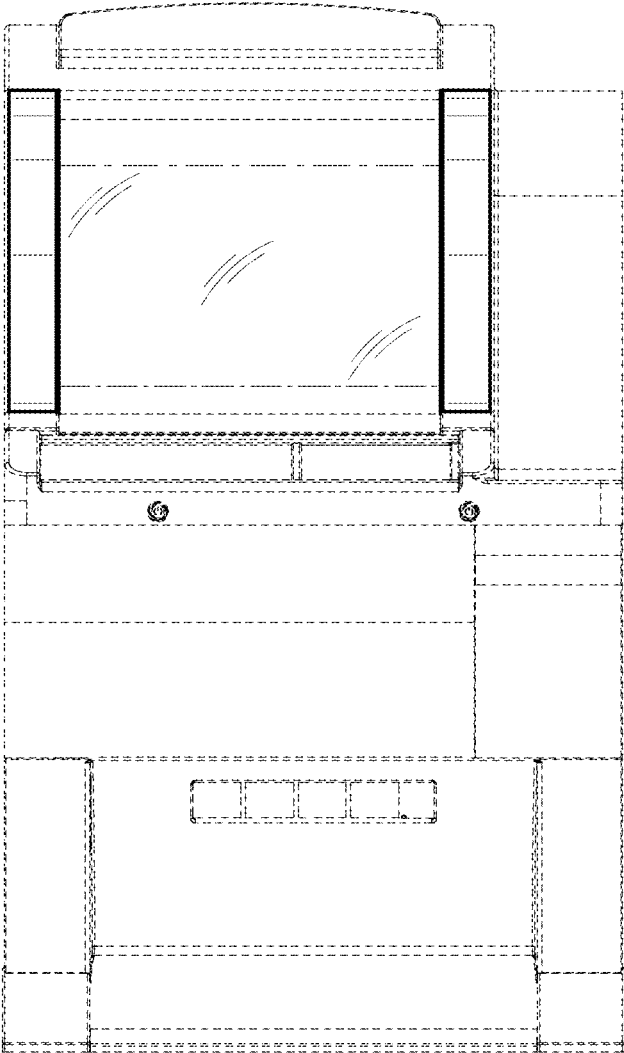

FIG. 13

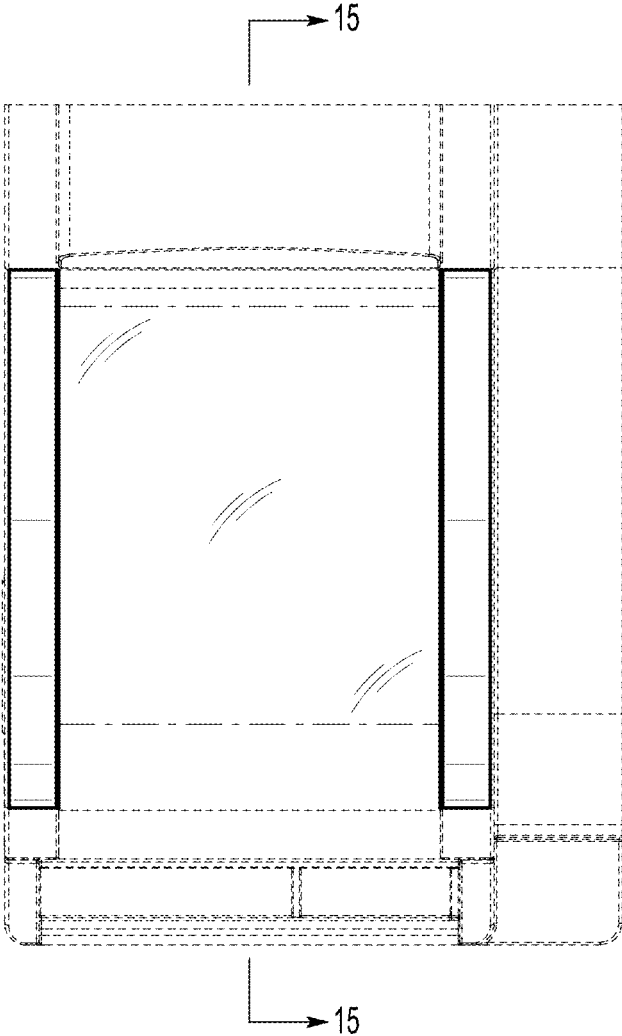

FIG. 14

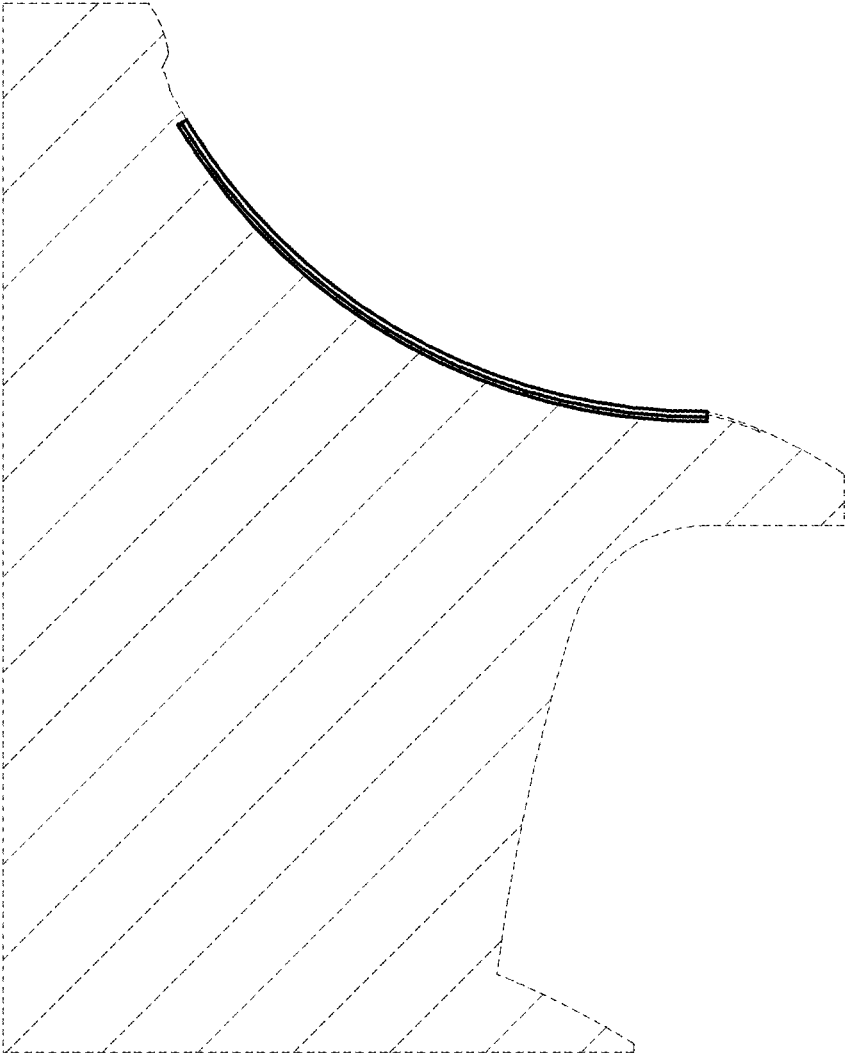

FIG. 15

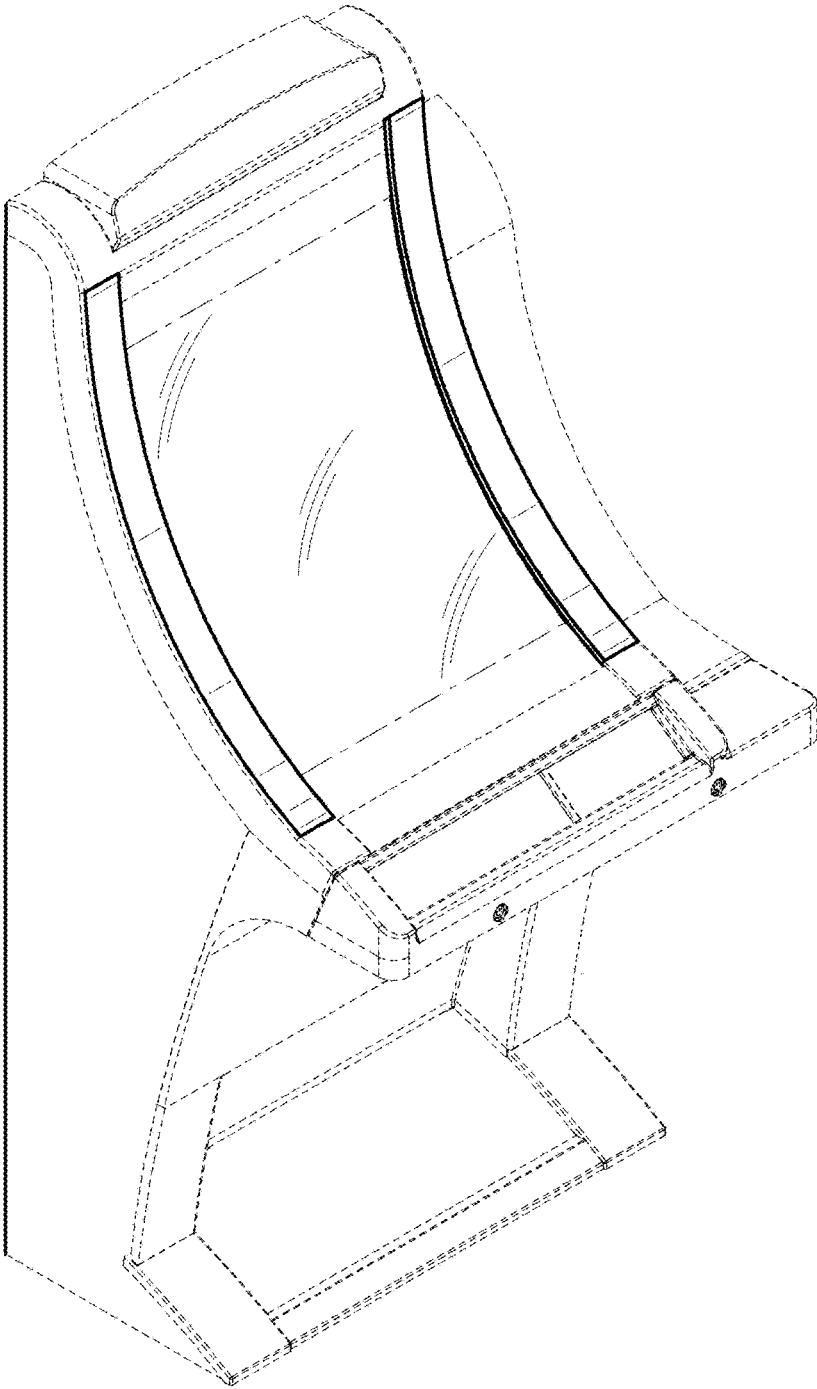

FIG. 16

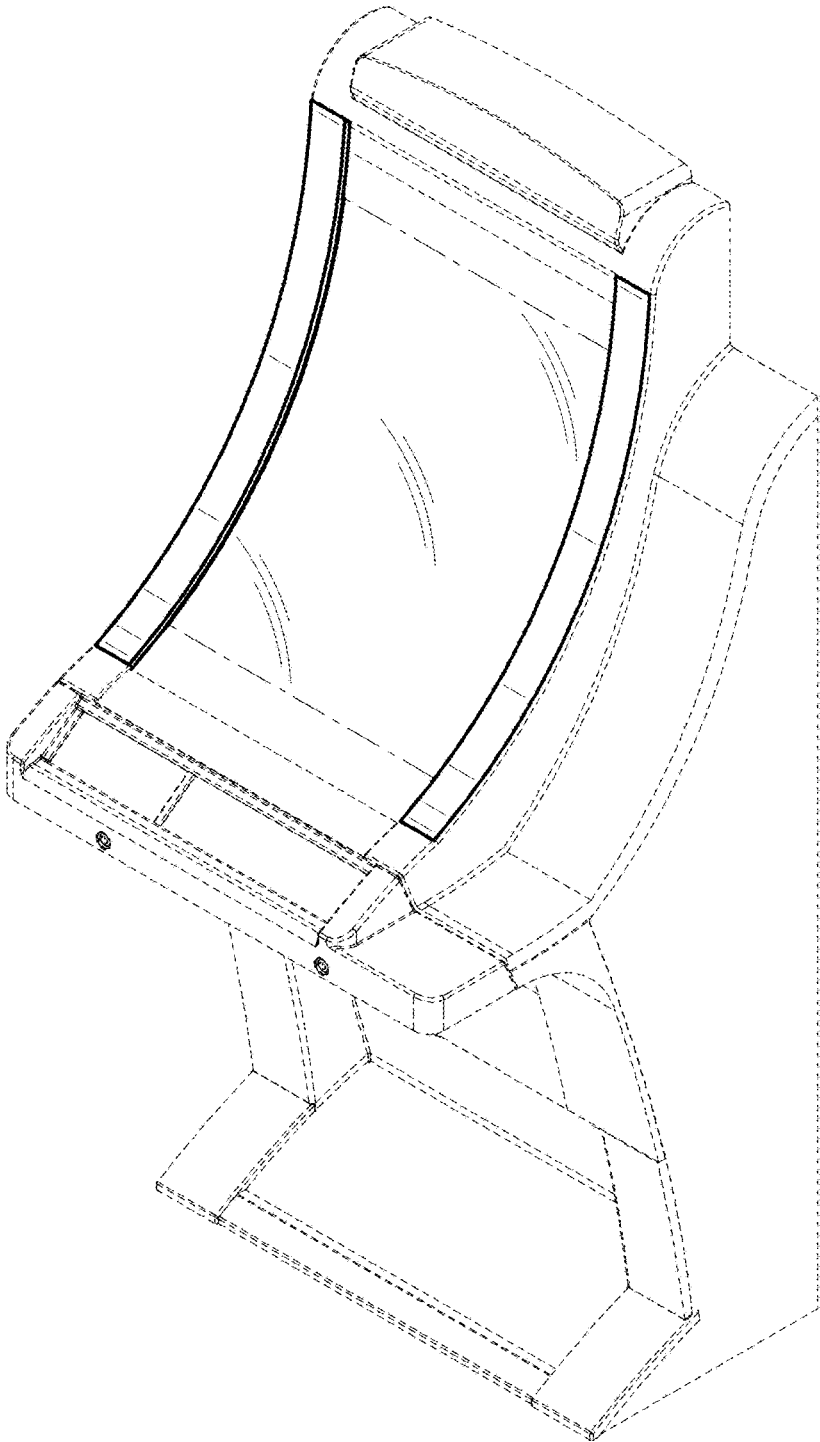

FIG. 17

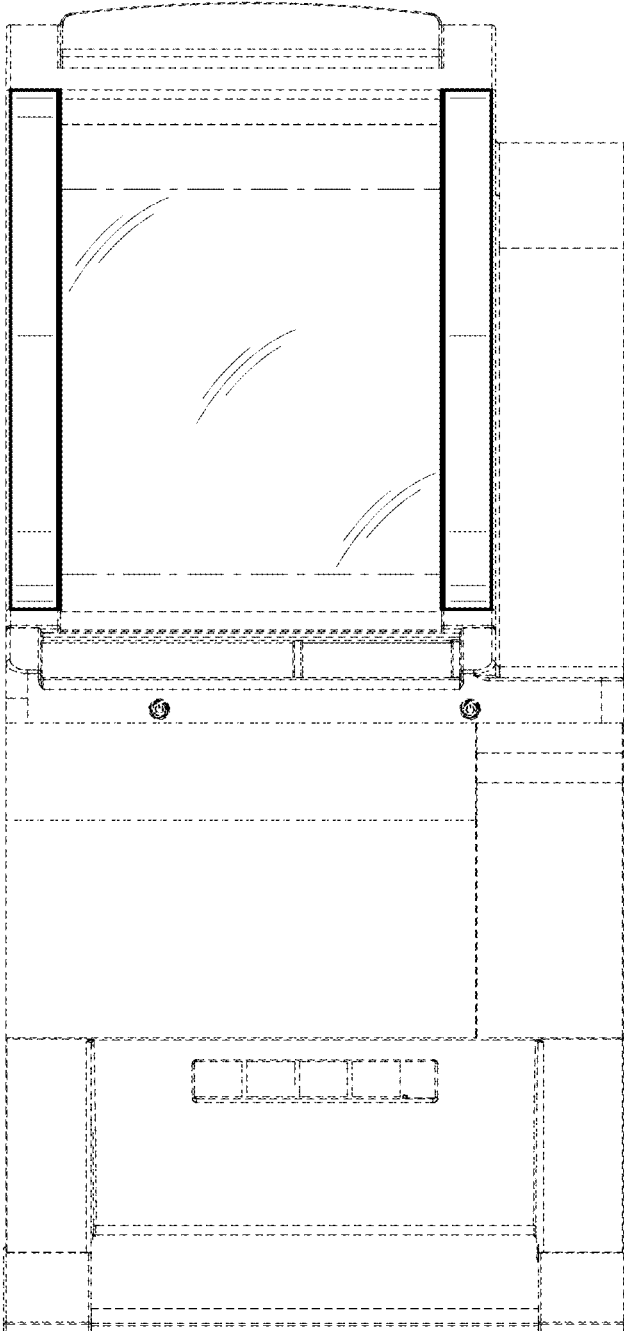

FIG. 18

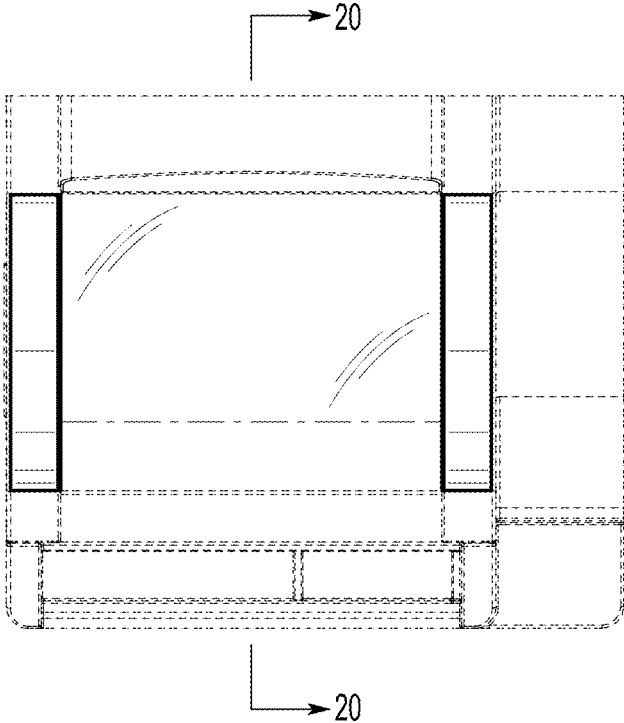

FIG. 19

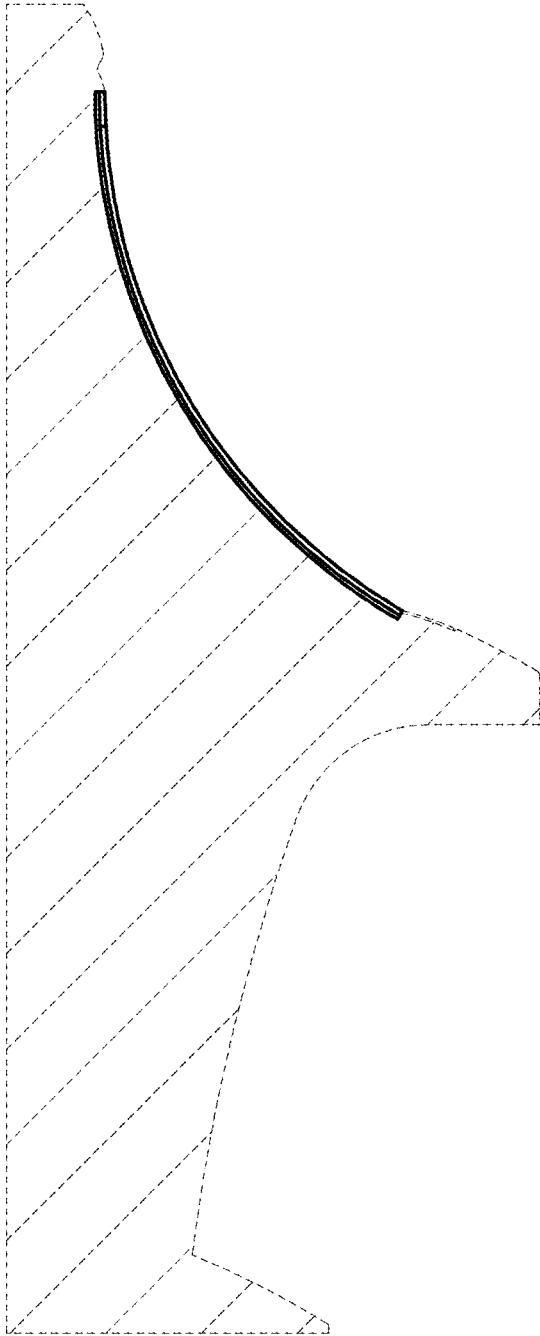

FIG. 20