

(19) World Intellectual Property Organization
International Bureau



(43) International Publication Date
29 September 2005 (29.09.2005)

PCT

(10) International Publication Number
WO 2005/091509 A1

- (51) International Patent Classification⁷: **H03M 13/27**
- (21) International Application Number: PCT/EP2005/002221
- (22) International Filing Date: 3 March 2005 (03.03.2005)
- (25) Filing Language: English
- (26) Publication Language: English
- (30) Priority Data:
04005627.7 10 March 2004 (10.03.2004) EP
60/553,438 16 March 2004 (16.03.2004) US
- (71) Applicant (for all designated States except US): TELEFONAKTIEBOLAGET L M ERICSSON (PUBL) [SE/SE]; S-164 83 Stockholm (SE).
- (72) Inventor; and
- (75) Inventor/Applicant (for US only): BERKEMAN, Anders [SE/SE]; Kulgränden 15 A, S-226 49 Lund (SE).
- (74) Agent: STRÖM & GULLIKSSON AB; P.O. Box 793, S-220 07 Lund (SE).
- (81) Designated States (unless otherwise indicated, for every kind of national protection available): AE, AG, AL, AM, AT, AU, AZ, BA, BB, BG, BR, BW, BY, BZ, CA, CH, CN, CO, CR, CU, CZ, DE, DK, DM, DZ, EC, EE, EG, ES, FI, GB, GD, GE, GH, GM, HR, HU, ID, IL, IN, IS, JP, KE, KG, KP, KR, KZ, LC, LK, LR, LS, LT, LU, LV, MA, MD, MG, MK, MN, MW, MX, MZ, NA, NI, NO, NZ, OM, PG, PH, PL, PT, RO, RU, SC, SD, SE, SG, SK, SL, SM, SY, TJ, TM, TN, TR, TT, TZ, UA, UG, US, UZ, VC, VN, YU, ZA, ZM, ZW.
- (84) Designated States (unless otherwise indicated, for every kind of regional protection available): ARIPO (BW, GH, GM, KE, LS, MW, MZ, NA, SD, SL, SZ, TZ, UG, ZM, ZW), Eurasian (AM, AZ, BY, KG, KZ, MD, RU, TJ, TM), European (AT, BE, BG, CH, CY, CZ, DE, DK, EE, ES, FI, FR, GB, GR, HU, IE, IS, IT, LT, LU, MC, NL, PL, PT, RO,

[Continued on next page]

(54) Title: ADDRESS GENERATOR FOR AN INTERLEAVER MEMORY AND A DEINTERLEAVER MEMORY

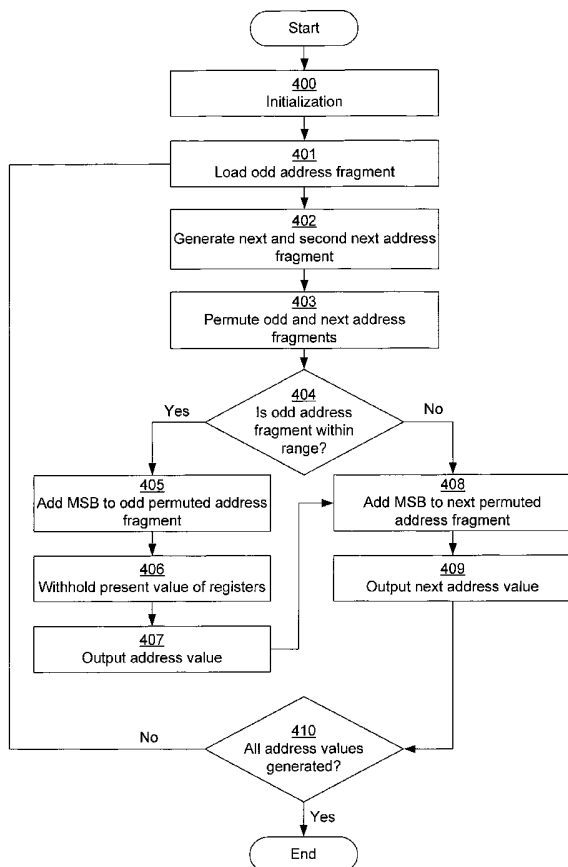

(57) Abstract: Method and device for generating an address value for addressing an interleaver memory. Consecutive address fragments to which a most significant bit(s) is to be appended are generated. Only a fraction of the address fragments generated, which potentially will exceed a maximum allowable value, is compared to the maximum allowable value. If the compared address fragment exceeds the maximum allowable value it is discarded. If the compared address fragment does not exceed the maximum allowable value it is accepted.

WO 2005/091509 A1



SE, SI, SK, TR), OAPI (BF, BJ, CF, CG, CI, CM, GA, GN, GQ, GW, ML, MR, NE, SN, TD, TG).

For two-letter codes and other abbreviations, refer to the "Guidance Notes on Codes and Abbreviations" appearing at the beginning of each regular issue of the PCT Gazette.

Published:

— *with international search report*

ADDRESS GENERATOR FOR AN INTERLEAVER MEMORY AND A DEINTERLEAVER MEMORY

Technical Field of the Invention

The present invention relates to a method for
5 generating address values for addressing a memory. More
specifically, the address values are generated as they are
needed for addressing the memory. The invention also
relates to a device for generating address values for
addressing a memory.

10

Description of Related Art

Interleaving/deinterleaving is used to render a
bursty communication channel into a communication channel
having seemingly independent errors. By interleaving data
15 to be transmitted, error bursts due to the bursty channel
are split up after deinterleaving and thus distributed over
a wider range of received symbols. When the transmitted
data are received and deinterleaved, a code suitable for
correcting independent errors can be used to restore the
20 data.

In the interleaver/deinterleaver, a memory is used
for storing blocks of data to be interleaved/deinterleaved.
The memory may be large, and it is therefore preferred to
calculate the address pattern for addressing the memory on-
25 the-fly, i.e. as the addresses are needed. Alternatively,
the addresses may be kept in a table, which requires
additional storage capacity.

The address patterns may be calculated using LFSR
(Linear Feedback Shift Register) techniques. Typically, the
30 LFSR is adapted to generate maximum length or PN (Pseudo
Noise) sequences.

An address value may be provided by generating an
address fragment, to which one or several most significant
bits (MSB) are appended. However, it is a problem with such
35 address generation techniques that the generated address

may be out of range of the allowable addresses when the MSB is appended. If the generated address value is out of range it has to be discarded, and a new address value has to be generated instead. To make sure that all generated
5 addresses are within range, all generated address value have to be compared to a maximum allowable value. Thus, a large number of unnecessary comparisons are made, which requires unnecessary time and processing capacity.

In the DVB (Digital Video Broadcasting) standard ETSI
10 EN300744, v1.4.1, ETSI, January 2001, symbol interleaving from index q to index $H(q)$ is defined. Both q and $H(q)$ are composed of N_r bits. Calculation of $H(q)$ includes generating an N_r-1 bit word R_i , which is a permuted version of R'_i , the state of an LFSR.

15 Running the algorithm for symbol interleaving for $i=0,1,\dots,M_{\max}-1$, where M_{\max} is the length of the maximum length sequence output by the LFSR, will result in generation of all valid $H(q)$ values, $q=0,1,\dots,N_{\max}-1$, where N_{\max} is the number of addresses of the wanted interleaving sequence.
20 Since $M_{\max}>N_{\max}$ it has to be checked, for each generated $H(q)$, that $H(q)$ is valid, i.e. that $H(q)$ is less than N_{\max} .

The most significant bit of $H(q)$ does not depend on R_i , but toggles for every i . Since the maximum length sequence contains an odd number of states of the LFSR ($2^{N_r}-1$), the PN-sequence is run twice before the interleaver
25 pattern repeats itself.

In the above-mentioned version of the DVB standard, two major modes are defined, the 8k mode ($N_r=13$) and the 2k mode ($N_r=11$). Also, a 4k mode ($N_r=12$) is envisaged. The
30 different modes may be summarized as:

mode	N_r	M_{\max}	N_{\max}
2k	11	2048	1512
4k	12	4096	3024
8k	13	8192	6048

In approximately 35% ($(M_{\max}-N_{\max})/N_{\max}$) of the loop iterations $H(q)$ has to be recomputed, since the calculated value is out of range ($H(q) \geq N_{\max}$). This leads to a corresponding increase in execution time. However, as $H(q)$ is compared in all generated loop iterations in the prior art, many unnecessary comparisons are made, resulting in non-optimal execution time and energy consumption.

The same problem occurs also in the deinterleaving process, wherein the mapping of the memory is the inverse of $H(q)$.

What has been described above in relation to the DVB standard is also applicable to other interleaving schemes wherein appending one or several MSB to a generated address fragment will generate address values, which potentially are not within range, wherein a generated address value has to be checked to not exceed a maximum allowable value.

US-B1-6 314 534 discloses a method and apparatus for address generation in an interleaver. An address is generated using a random address fragment and a bit reversed address fragment. It is a problem with this address generator in that the comparison to make sure that the address is within range is made every clock cycle. Thus, the execution time will be unnecessary long as addresses that are within range are compared.

US-B1-6 549 998 discloses an interleaver for generating a valid interleaved address for each iteration. An address generator comprises two counters for addressing parallel lookup tables. A magnitude comparison is made to select the proper output. It is a problem with this address

generator in that it comprises two counters, which makes it complicated. Furthermore, a comparison to make sure that the generated address is within range is made in each clock cycle. Also, as the address generator comprises two
5 registers for storing tentative address values, an unnecessary amount of memory capacity is required.

Summary of the Invention

It is an object of the invention to provide a method
10 and a device for decreasing the processing capacity needed for generating address values based on address fragments to which at least one most significant bit (MSB) is appended.

The object of the invention is achieved by a method for generating an address value for addressing a memory.
15 According to the method, consecutive address fragments, to which at least one most significant bit is to be appended, are generated. Only a fraction of the address fragments, which potentially will generate an address value out of range, is compared to a maximum allowable value. If the
20 compared address fragment exceeds the maximum allowable value, the compared address fragment is discarded. However, if the compared address fragment does not exceed the maximum allowable value the compared address fragment is accepted.

25 The fraction of address values compared given a predetermined number of address values of an interleaving sequence is dependent on the number of MSBs. The fraction may e.g. be $\frac{1}{2}$ if only one MSB is appended.

If necessary, the address fragments are permuted
30 before or after being compared.

The address fragment following the compared address fragment is either generated in the same clock cycle as the compared address fragment, or in response to discarding or accepting the compared address fragment.

The next and second next address fragments following the compared address fragment may be generated by means of a feedback function.

The object of the invention is also achieved by a
5 device for generating address values for addressing a memory. The device comprises a shift register having a predetermined number of registers for generating a maximum length pseudo noise (PN) sequence, i.e. consecutive address
10 fragments. Comparator means is adapted to compare a fraction of the address fragments generated with a maximum allowable value. The compared address fragments will possibly generate address values out of range. A selector means is adapted to discard the compared address fragment if it exceeds the maximum allowable value, and to accept
15 the compared address fragment otherwise.

A toggle means may be provided to append at least one bit being the most significant bit to any address fragment, or permuted address fragment, to generate the address value.

20 The device may be implemented by software comprising readable program means to be run by a processor. Alternatively, the device may be implemented as an application specific integrated circuit (ASIC) or a field programmable gate array (FPGA).

25 An interleaver for interleaving a block of data, comprising an interleaver memory and a device for generating address values according to the invention for addressing the memory also achieves the object of the invention.

30 A deinterleaver for interleaving a block of data, comprising a deinterleaver memory and a device for generating address values according to the invention for addressing the memory also achieves the object of the invention.

A communication apparatus for communicating data, comprising a memory and a device for generating address values according to the invention for addressing the memory also achieves the object of the invention.

5 Also, a software program product embodied on a computer readable medium comprising instructions for carrying out the method according to the invention when said product is run by a processor achieves the object of the invention.

10 Further embodiments of the invention are defined in the dependent claims.

It is an advantage of the invention that the processing capacity needed compared to address generation schemes known in the art is decreased. More specifically, 15 the algorithm for generating address values presented in the ETSI standard mentioned above performs substantially more comparisons than according to the invention, resulting in non-optimal processing time and energy consumption. Thus, the present invention results in faster execution 20 time, and since unnecessary operations are removed, decreased energy consumption.

It should be emphasized that the term "comprises/comprising" when used in this specification is taken to specify the presence of stated features, integers, 25 steps or components but does not preclude the presence or addition of one or more other features, integers, steps, components or groups thereof.

Brief Description of the Drawings

30 Further objects, features and advantages of the invention will appear from the following detailed description of the invention, reference being made to the accompanying drawings, in which:

Fig. 1 is a schematic view of a mobile terminal 35 connected to a mobile communication network;

Fig. 2 is a block diagram of communication components of the mobile terminal of Fig. 1;

Fig. 3 is block diagram of an interleaver according to the invention;

5 Fig. 4 is block diagram a first embodiment of an address generator according to the invention;

Fig. 5 is a second embodiment of an address generator according to the invention;

10 Fig. 6 is a third embodiment of an address generator according to the invention; and

Fig. 7 is a flow chart of a method for generating address values according to the invention.

Detailed Description of Embodiments

15 Fig. 1 illustrates a mobile terminal 1 embodied as a mobile telephone, as one example of a communication apparatus comprising an interleaver according to the invention. The invention is not only applicable to a mobile terminal, but can be incorporated into any electronic
20 communication apparatus, such as a portable communication apparatus, a mobile radio terminal, a pager, a communicator, an electronic organizer, a smartphone, a set-top-box, a TV-set, or a mobile television receiver, which has a need for sending and/or receiving interleaved data.
25 The present invention may also be implemented in electronic devices which communicates over a cable or fiber connection, and is not limited to wireless communication.

The mobile terminal 1 comprises a user interface for user interaction, which e.g. may comprise a microphone 2, a
30 loudspeaker 3, a keypad 4 and a display 5. The mobile terminal 1 also comprises a communication interface including an antenna 6 for communicating with a mobile communication network 10, or other electronic equipment, over a wireless communication link 11. The communication
35 interface may also be adapted to communicate with other

networks, such as a network for digital video broadcasting (DVB), wherein the mobile terminal 1 is adapted to communicate directly with the DVB network. The communication interface for communicating with a mobile communication network or a DVB network could also be adopted to only receive DVB transmissions. That is, the mobile terminal 1 is not necessarily connected to a network (such that the network is aware of the presence of the mobile terminal) since the DVB transmissions are broadcast and hence the communication is one-way only.

Fig. 2 illustrates the communication interface of the terminal 1 in more detail. The communication interface comprises a communication unit including e.g. a receiver/transmitter (Tx/Rx) unit 21, a modulator/demodulator unit 22, and a coder/decoder unit 23 connected to other units of the mobile terminal 1. The coder/decoder unit 23 comprises an interleaver/deinterleaver 30 according to the invention. The interleaver/deinterleaver 30 may alternatively be provided as a stand-alone unit. Furthermore, the communication interface may also be adapted to communicate over a cable or fiber connection.

Fig. 3 illustrates the interleaver/deinterleaver 30 in more detail. The interleaver/deinterleaver 30 comprises an interleaver/deinterleaver memory 31 adapted to store a predetermined number of data blocks, each having a certain number of bits. The memory 31 forms an array having a predetermined number of rows and columns. Blocks of data are read into the interleaver/interleaver memory 31 in a first order, and read out from the memory in a second order being different from the first order. Address values are generated for addressing each memory position of the array. To form blocks of data to be transmitted, the memory positions are addressed according to the interleaving pattern, which is often constructed to have random-like

properties. The formed blocks thus comprise seemingly independent interleaved bits. After transmission, the transmitted blocks are deinterleaved, i.e. read into a deinterleaving memory, wherein the original blocks of data are restored. Thus, bit errors due to a bursty channel during transmission will be spread out. The errors may be restored by utilizing an error correction scheme. In the following, we will make reference to an interleaver and an interleaver memory, or simply memory, and its functionality for simplicity of notation. However, the present invention is equally relevant for a deinterleaver.

An interleaver address generator 40 is connected to the memory 31, and ensures that a proper address value is generated. The generated address value may be supplied to a controller 32, such as a central processing unit, which will address the memory and retrieve bits to be forwarded for transmission or use by other units of the terminal 1. Alternatively, the output of the address generator 40 is directly forwarded to the memory 31, which will output the data stored at the memory position corresponding to the specific address value.

Fig. 4 illustrates in more detail an embodiment of a device for generating address values, or an address generator 100, according to the invention. The address generator 100 may e.g. be implemented as an application specific integrated circuit (ASIC), a field programmable gate array, hard-wired logic, or by software instructions to be executed by a processor of the terminal 1. The address generator 100 comprises a predetermined number ($N_r - 1$) of registers 110a-110d required for generating an address fragment comprising a predetermined number of bits. Each input terminal of the registers 110a-110d is connected to an output terminal of a multiplexor 120a- 120d. An output terminal of each register 110a-110d is connected to a first input terminal of the multiplexors 120a-120d. Also,

the output terminals of the registers 110a-110d are operatively connected, through a bus, to a first permutation unit 130a. The output of the registers 110a-110d together form a vector denoted address fragment R'_i below. The first permutation unit 130a is adapted to permute the address fragment into a second vector R_i denoted permuted address fragment in the following. The permutation may be carried out according to different schemes. One scheme for permuting the address fragment R'_i to satisfy the DVB standard is disclosed in ETSI EN300744, v1.4.1, ETSI, January 2001, which is enclosed herein by reference.

The output terminals of the registers 110a-110d are also connected to a first address fragment calculation unit 140a, which is adapted to generate a consecutive next address fragment R'_{i+1} based on the present address fragment R'_i by means of an address calculation or feedback function $g(x)$. One scheme for calculating the next address fragment R'_{i+1} by means of $g(x)$ is presented in the above-mentioned ETSI standard. However, other schemes are also possible as long as a next address fragment is generated. Output terminals of the first address fragment calculation unit 140a are operatively connected, by means of a bus, to a second permutation unit 130b. The second permutation unit 130b is adapted to permute the next address fragment R'_{i+1} to a permuted next address fragment R_{i+1} according to the same principles as discussed in relation to the first permutation unit 130a.

Output terminals of the first address fragment calculation unit are also connected to a second address fragment calculation unit 140b. The second address fragment calculation unit 140b is adapted to calculate the second next address fragment R'_{i+2} based on the next address fragment R'_{i+1} by means of the address calculation function $g(x)$. Output terminals of the second address calculation

unit 140b are operatively connected to second input terminals of each multiplexor 120a-120d, wherein the values of the binary word R'_{i+2} may be fed back to the registers 110a-110d.

5 The present address fragment R'_i , the next address fragment R'_{i+1} and the second next address fragment R'_{i+2} are available during the same clock cycle. Thus, at the input terminals of each multiplexor 120a-120d are the present value of each register 110a-110d, and the second next value
10 as determined by the second address calculation unit 140b, available. Either of the present value or the second next value will be input to the registers in the next clock cycle, as will be described below.

 Output terminals of the first and second permutation
15 units 130a, 130b are connected to a selector unit 150. The selector unit 150 is adapted to select either the present permuted address fragment R_i or the next permuted address fragment R_{i+1} , which are both available at the same clock cycle, based on a control signal M received from a
20 comparator 160.

 A toggle unit 170 is adapted to concatenate or append one or several MSBs (Most Significant Bits) to the output from the selector 150. According to the above-mentioned standard, if the present address fragment R_i is output from
25 the selector, a 1 is appended. If the next address fragment R_{i+1} is output from the selector 150, 0 is appended. Thus, the complete address value $H(q)$ for addressing the memory 31 is generated.

 The present invention is not limited to a single bit
30 as the MSB. One or several bits may be appended to the permuted address fragment to generate the address value. Then the toggle unit is adapted to toggle the MSBs between several values, some of which will generate address values out of range. Depending on the number of MSBs appended,
35 only a fraction of the generated address values have to be

wanted range of zero to 6047. Thus, it is only necessary to determine whether permuted address fragments to which a 1 is to be appended as an MSB are within range, i.e. only every second address fragment is compared when only one bit is appended as the MSB. Therefore, the comparator 160 is adapted to determine whether the present permuted address fragment is out of range, i.e. whether R_i is less than or equal to N_{\max} as adjusted for the MSB. To satisfy the DVB standard, the comparator 160 is adapted to determine whether $R_i < 488, 976, \text{ or } 1952$ (6048-4096=1952) depending on the used mode (2k, 4k, or 8k mode). It should be noted that the same compare function may be used for all three modes, as $1952 = 2 \times 976 = 2 \times 2 \times 488$. In the above example, it is determined whether the value of the permuted address fragment is less than 1952. I.e. a permuted address fragment having the value 1951 is the largest address fragment that will generate an address value within range if a 1 is appended as the MSB.

If R_i is within range, the comparator 160 outputs the control signal M with information to the selector 150 to output the compared permuted address fragment R_i . Also, the comparator 160 outputs a toggle control signal received by the toggle unit 170, which will append a 1 as the MSB of R_i . Furthermore, the comparator 160 outputs a shift register control signal E, which is received at a third input of the multiplexors 120a-120d. If the multiplexors 120a-120d receive the control signal E, the present values of the registers 110a-110d are maintained in the registers. During the next clock cycle, the comparator 160 instructs the selector 150 to output the next address fragment R_{i+1} without making any comparison, and instructs the toggle unit to append a 0 as the MSB of R_{i+1} .

During the clock cycle following the outputting of the next address fragment R_{i+1} , the registers 110a-110d are

updated with the second next address fragment R'_{i+2} , and i is incremented by 2.

If a compared permuted address fragment is out of range, the comparator 160 outputs the control signal M with information to the selector 150 to output the next permuted address fragment R_{i+1} . Also, the comparator 160 instructs the toggle unit 170 to append a 0 as the MSB to the next permuted address fragment R_{i+1} . Furthermore, when the address fragment is out of range, the values of the registers 110a-110d are not withheld but updated during the next clock cycle.

The procedure of comparing every second address fragment, outputting or discarding the compared address value, and outputting the next address value is repeated until all values of i are iterated.

Thus, according to the embodiment of Fig. 4, a correct address value is generated in every clock cycle. Furthermore, comparisons are only made where necessary and not for every data. Thus the processing time and processing requirements for generating valid address values are decreased, which saves power.

Fig. 5 illustrates a second embodiment of a device 200 for generating address values according to the invention. Components corresponding to components of the embodiment of Fig. 4 are denoted by the same reference numerals. In the embodiment of Fig. 5, the present address fragment R'_i and the next address fragment R'_{i+1} are generated during consecutive clock cycles. During a first clock cycle, the present address fragment is available from the registers 110a-110d, and permuted by the single permutation unit 130a. For every second, i.e. odd generated permuted address fragment, the comparator 260 is adapted to determine whether the permuted address fragment is within range, according to the same principles as described above. For every even permuted address fragment, the comparator

260 is adapted to acknowledge the output of the permutation unit 130a without any comparison.

If the present permuted address fragment R_i is odd and is determined to be within range, the comparator 260 will instruct the toggle unit 170 to append a 1 as the MSB. Also, the comparator may issue a data available signal, e.g. to the controller 32, when the address value is available at the output of the address generator. Then, the comparator is adapted to update the registers 110a-110d with the output of the first address fragment calculation unit. Thus each register 110a-110d will comprise the value for the next address fragment. During the next clock cycle, the next, even, permuted address fragment will be generated and the next even address value (having a 0 as MSB) is generated without any comparison.

If the present permuted address fragment R_i is odd and determined being out of range, the comparator 260 will not issue the data available signal until a new address value is generated. Thus no address value will be generated during the present clock cycle. In the following clock cycle, the next, even, permuted address fragment will be generated. The comparator 260 then directly without making any comparison instructs the toggle unit 170 to append a 0 as the MSB and issues the data available signal.

Fig. 6 illustrates a third embodiment of an address generator 300 according to the invention. Components corresponding to components of the embodiment of Fig. 4 are denoted by the same reference numerals. In the embodiment of Fig. 6, the present, the next and the second next address fragments are generated according to the same principles as described in relation to Fig. 4. The difference is that in the embodiment of Fig. 6 the comparator 360 is adapted to determine whether the present (odd) address fragment will generate a permuted address fragment, and consequently the address value, which may be

out of range. Thus, the comparator 360 has knowledge of which address fragments that may generate permuted address fragments out of range. Such address fragments may be stored in an internal memory 361 or register of the
5 comparator 360. The generated present address fragment is compared to address fragment values stored in the memory 361 to check whether the present permuted address fragment will be within range. If so, the comparator instructs the selector 150 to output the present permuted address
10 fragment, and instructs the toggle unit 170 to append a 1 as the MSB. However, if the comparator 360 determines that the present address fragment is out of range, the present address fragment will be discarded. Then, the comparator will instruct the selector to output the next (even)
15 permuted address fragment without any comparison, and instruct the toggle unit to append a 0 as the MSB.

In the above embodiments, the three first address values, $R'_0=0$, $R'_1=0$, $R'_2=1$, which gives $H(0)=0$, $H(1)=2^{Nr-1}$, and $H(2) \leq 2^{Nr-2}$, are taken care of separately, e.g. by the
20 controller 32, since it is known beforehand that the resulting addresses are within range.

Furthermore, in the above embodiments the generated address fragments are permuted. However, permuting the address fragments may not be necessary if the registers are
25 arranged to generate address fragments, to which an MSB directly may be appended to generate the address value. Also, appending the MSB may also not be necessary if the registers are arranged to generate the address values directly.

30 Fig. 7 illustrates one embodiment of the method according to the invention for generating address values for addressing the memory 31. In a first step 400, the procedure is initialized by taking care of the first three address fragments.

In step 401 the present (odd) address fragment (which is the second next address fragment from the previous cycle, except during the first cycle when the present odd address fragment is R'_3) is loaded into the registers, and
5 in step 402 the next (even) and second next address fragments are generated. If required, the present and next address fragments are permuted in step 403. In step 404 it is determined whether the odd permuted address fragment is within range. If the answer in step 404 is yes, a 1 is in
10 step 405 appended as an MSB to the address fragment permuted in step 403. In step 406, the present values of the registers are withheld. The generated present (odd) address value is then output in step 407.

If the answer in step 404 is no, the procedure
15 proceeds to step 408, wherein a 0 is appended as an MSB to the next (even) permuted address fragment. Then, the next address value is output in step 409.

In step 410 it is determined whether all possible address values have been generated. If not, the procedure
20 returns to step 401. Otherwise, the procedure is ended.

The method according to the invention has been described in relation to a number of steps. Some of the steps are not necessary to carry out the method according to the invention depending on the specific embodiment. The
25 permutation may e.g. not be executed in all embodiments of the invention. Furthermore, some of the steps may also be executed in a different order. The second next address fragment may e.g. be generated in step 401 when it is needed.

30 The present invention has been described in the above as applicable to generate and address value for addressing an interleaver memory, such that data written into the memory in linear order is read from the memory in an interleaved order. However, the invention is also
35 applicable to generate address values for addressing a

deinterleaver memory, such that data written into the memory in an interleaved order is read from the memory in a linear order. In such a case, the mapping process for generating the address values is the inverse of $H(q)$.

5 The present invention has been described above with reference to specific embodiments. However, other embodiments than the above described are equally possible within the scope of the invention. Different method steps than those described above, performing the method by
10 hardware or software, may be provided within the scope of the invention. The different features and steps of the invention may be combined in other combinations than those described. The invention is only limited by the appended
15 patent claims.

CLAIMS

1. A method for generating an address value for addressing a memory (31), comprising the step of generating a plurality of address fragments, **characterized** by the step of:

comparing only a fraction of the generated address fragments with a maximum allowable value.

2. The method according to claim 1, wherein every second address fragment is compared.

3. The method according to claim 1 or 2, further comprising the steps of:

discarding the compared address fragment if it exceeds the maximum allowable value; and accepting the compared address fragment otherwise.

4. The method according to any of the previous claims, further comprising the step of: permuting the generated address fragments, wherein the address fragments to be compared are permuted prior to or after the step of comparing.

5. The method according to any of the previous claims, further comprising the step of: appending at least one bit being the most significant bit(s) to any address fragment or permuted address fragment

6. The method according to any of the previous claims, wherein the compared address fragment is an odd address fragment to which a 1 is to be appended as a most significant bit.

7. The method according to any of the previous claims, wherein an even address fragment is generated in

response to discarding or accepting the compared address fragment.

8. The method according to any of the claims 1 to 6,
5 comprising the step of:

generating at least the odd address fragment to be compared and a following even address fragment during a first clock cycle;

10 if the compared odd address fragment is discarded, outputting the even address fragment during the first clock cycle;

if the compared odd address fragment is accepted, outputting the odd compared address fragment and retaining values of registers of a shift register during the first
15 clock cycle; and

outputting the even address fragment during a second clock cycle following the first clock cycle.

9. The method according to any of the previous
20 claims, comprising the step of:

generating a next odd address fragment; and

inputting the next odd address fragment into registers (120a-120d) of a shift register.

25 10. The method according to claim 8 or 9, wherein the next even and next odd address fragments are generated by means of a feedback function $(g(x))$.

11. A device (100, 200, 300) for generating address
30 values for addressing a memory (31), comprising means (110a-110d, 140a, 140b) for generating a plurality of address fragments, **characterized** by

comparator means (160, 260, 360) adapted to compare only a fraction of the plurality of address fragments
35 generated with a maximum allowable value.

12. The device according to claim 11, wherein the comparator is adapted to compare every second generated address fragment.

5 13. The device according to claim 11 or 12, further comprising selector means (150), which is adapted to discard the compared address fragment if it exceeds the maximum allowable value, and to accept the compared address fragment otherwise.

10

 14. The device according to any of the claims 11 to 13, further comprising permuting means (130a, 130b) adapted to permute the address fragments, the permuting means being provided prior to or after the comparator means (160, 260, 15 360).

 15. The device according to any of the claims 11 to 14, further comprising toggle means (170) adapted to append at least one bit being the most significant bit(s) to any 20 address fragment, or permuted address fragment, in order to generate the address value.

 16. The device according to any of the claims 10 to 13, wherein the compared address fragments are address 25 fragments to which a 1 is to be appended as a most significant bit.

 17. The device according to any of the claims 11 to 16, wherein the means (110a-110d, 140a) for generating 30 address fragments is adapted to generate a next even address fragment in response to discarding or accepting the compared address fragment.

18. The device according to any of the claims 11 to 16, wherein the means for generating address fragments comprises:

5 a shift-register comprising a predetermined number of registers (110a-110d) adapted to generate address fragments to be compared during a first clock cycle,

10 address fragment calculation means (140) adapted to generate a next even address fragment during the first clock cycle, which is based on the address fragment to be compared;

the selector means (150) is adapted to, if the compared address fragment is discarded, output the even address fragment in response to a first control signal (M) during the first clock cycle, and to output the compared address fragment during the first clock cycle if the compared address fragment is accepted, and to output the even address fragment during a second clock cycle following the first clock cycle; and

20 the shift register is adapted to retain present values of the registers during the first clock cycle in response to a second control signal (E) if the compared address fragment is accepted.

19. The device according to claim 18, wherein the address fragment calculation unit means (140a, 140b) is adapted to generate a next odd address fragment, based on the even address fragment, and feed back said next odd address fragment to the shift register.

30 20. The device according to claim 18 or 19, wherein the address fragment calculation means (140a, 140b) is adapted to generate the next even and next odd address fragments by means of a feedback function.

21. The device according to any of the claims 11 to 20, wherein the device (100, 200, 300) is implemented by software comprising readable program means to be run by a processor.

5

22. The device according to any of the claims 11 to 20, wherein the device (100, 200, 300) is implemented as an application specific integrated circuit.

10

23. The device according to any of the claims 11 to 20, wherein the device (100, 200, 300) is implemented as a field programmable gate array.

15

24. The device according to any of the claims 11 to 23, further comprising a shift register adapted to generate a maximum length pseudo noise sequence.

20

25. The device according to any of the claims 11 to 24, wherein the memory (31) is an interleaver memory.

26. The device according to any of the claims 11 to 24, wherein the memory (31) is a deinterleaver memory.

25

27. An interleaver for interleaving a block of data, comprising a memory (31) and a device (100, 200, 300) for generating address values according to any of the claims 11 to 25 for addressing the memory.

30

28. A deinterleaver for interleaving a block of data, comprising a memory (31) and a device (100, 200, 300) for generating address values according to any of the claims 11 to 24 and 26 for addressing the memory.

35

29. A communication apparatus for communicating data, comprising a memory (31) and a device according to any of

the claims 11 to 26 for generating address values for addressing the memory.

30. The communication apparatus according to claim
5 29, wherein the communication apparatus is a mobile radio terminal, a pager, a communicator, an electronic organizer, or a smartphone.

31. The communication apparatus according to claim
10 29, wherein the communication apparatus is a mobile telephone (1).

32. A communication apparatus for receiving data,
comprising a deinterleaver according to claim 28.
15

33. The communication apparatus according to claims
32, wherein the communication apparatus is a set-top-box, a TV-set, or a mobile television receiver.

20 34. A software program product embodied on a computer readable medium comprising instructions for carrying out the method according to any of the claims 1 to 10 when said product is run by a processor.

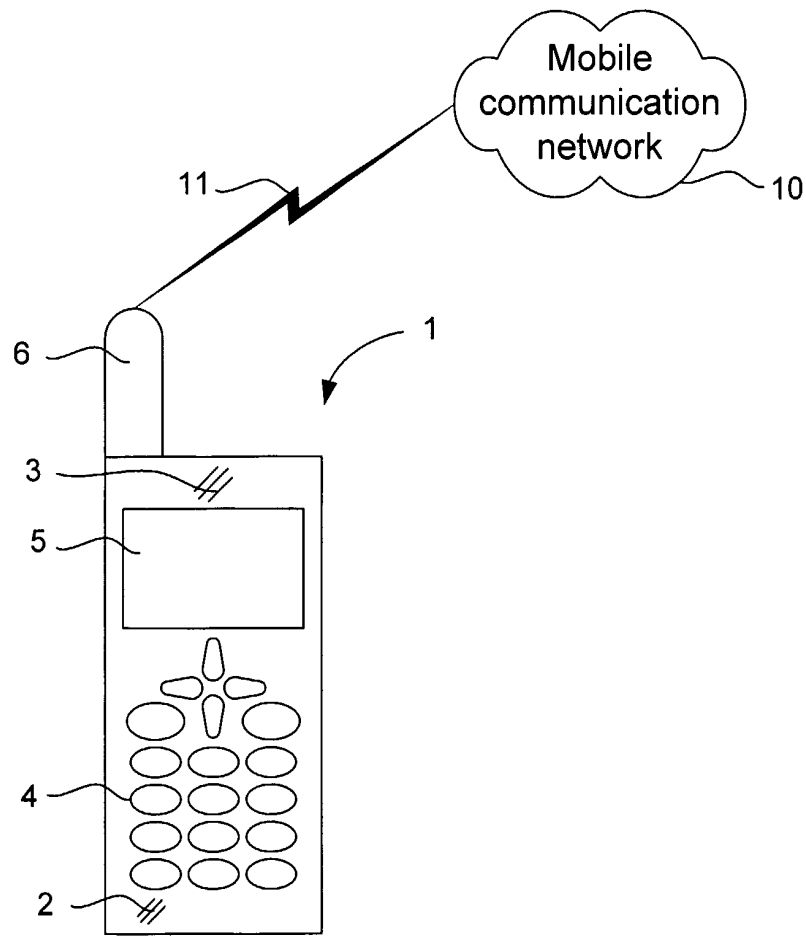

FIG. 1

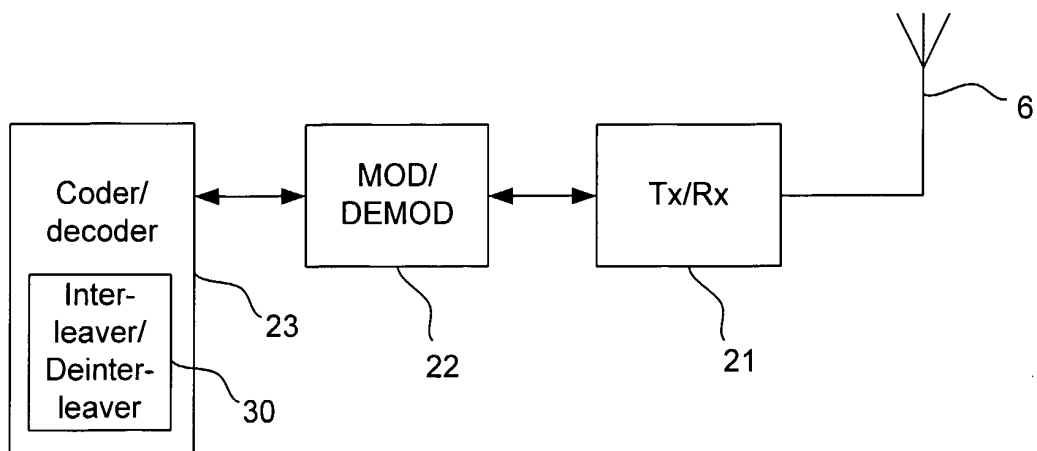

FIG. 2

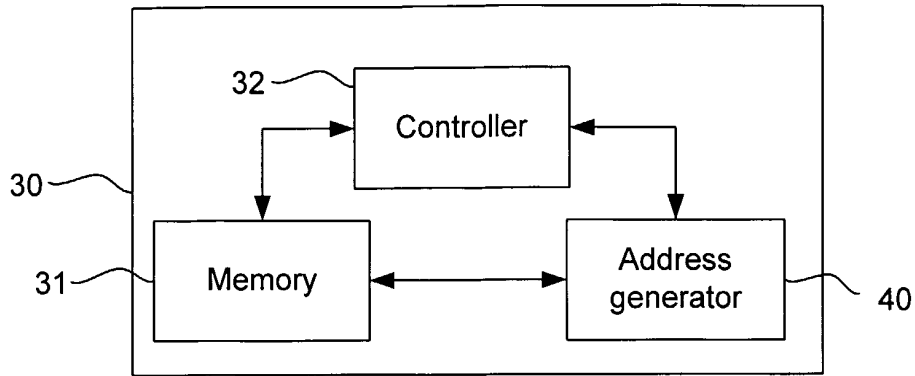

FIG. 3

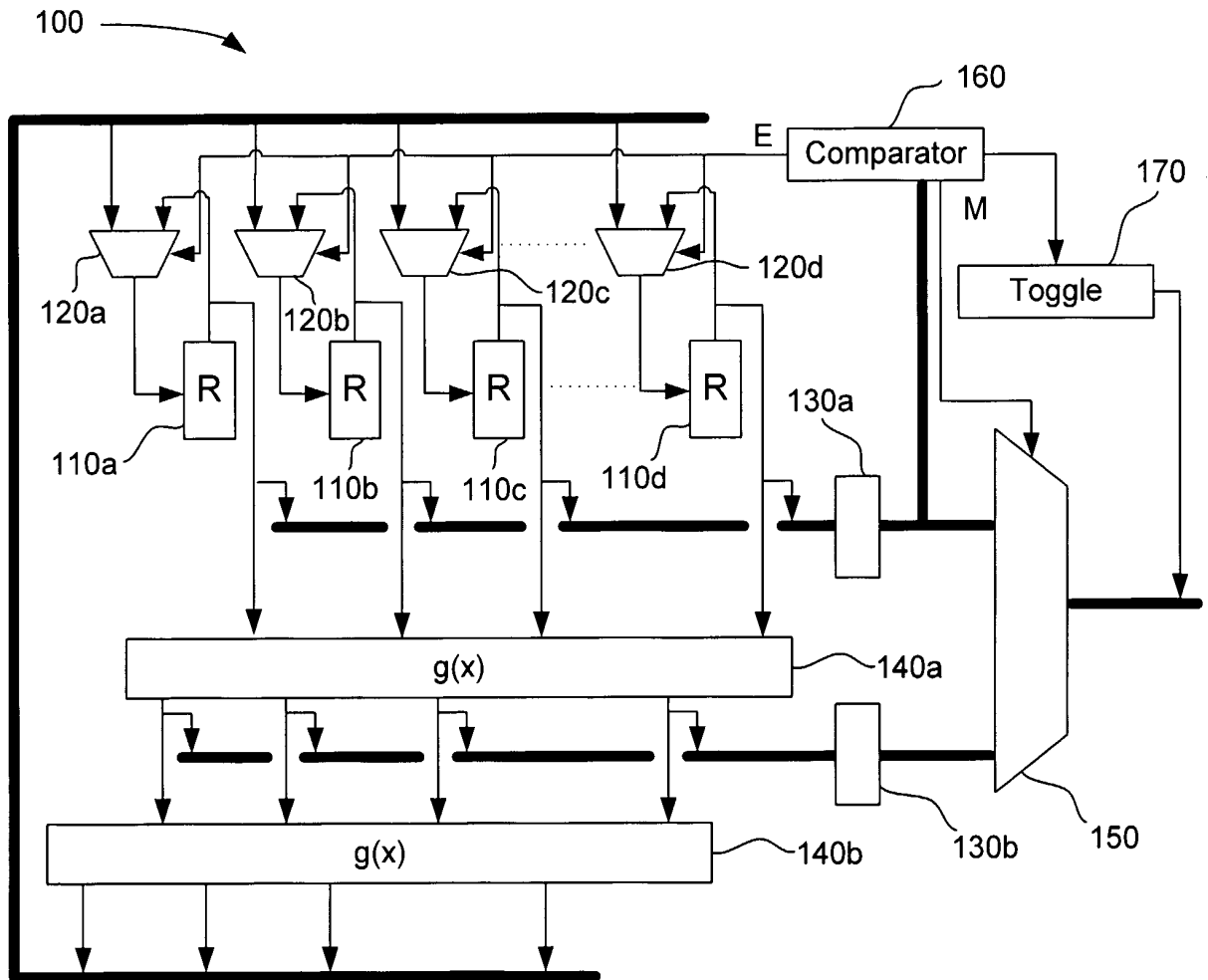

FIG. 4

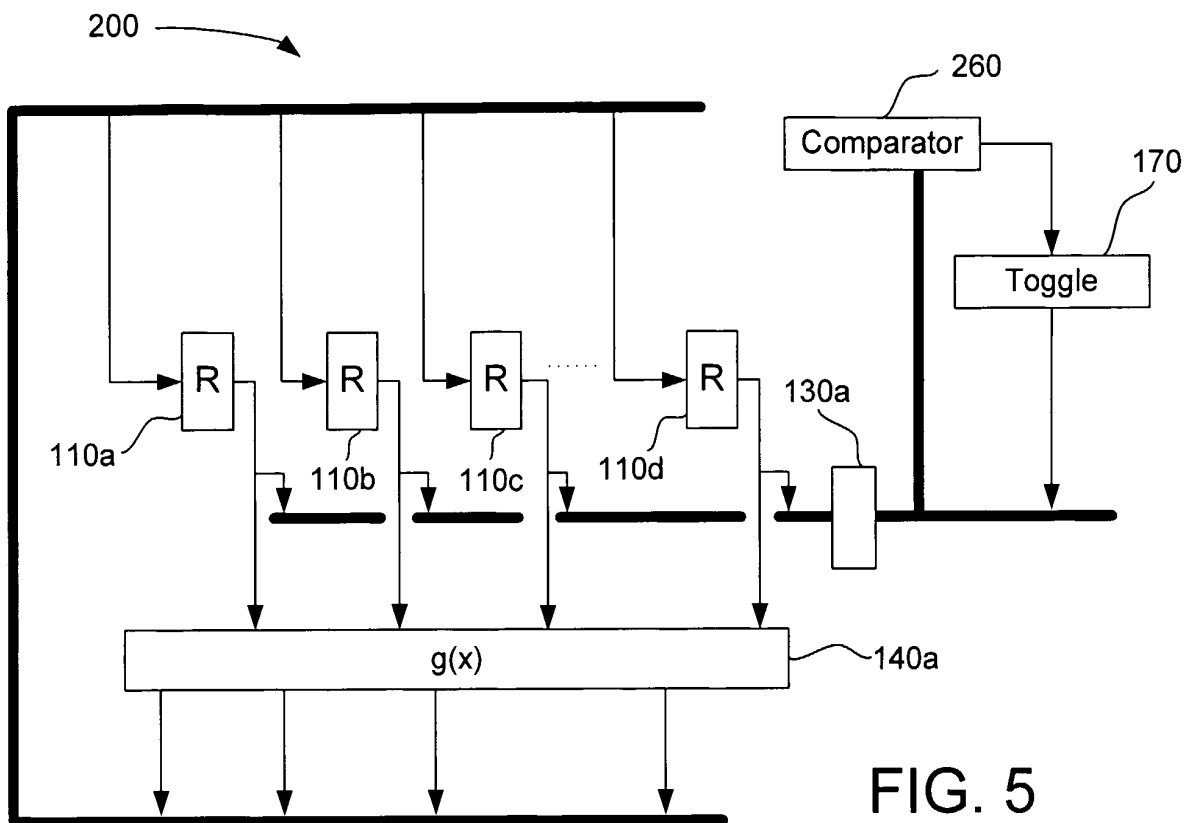

FIG. 5

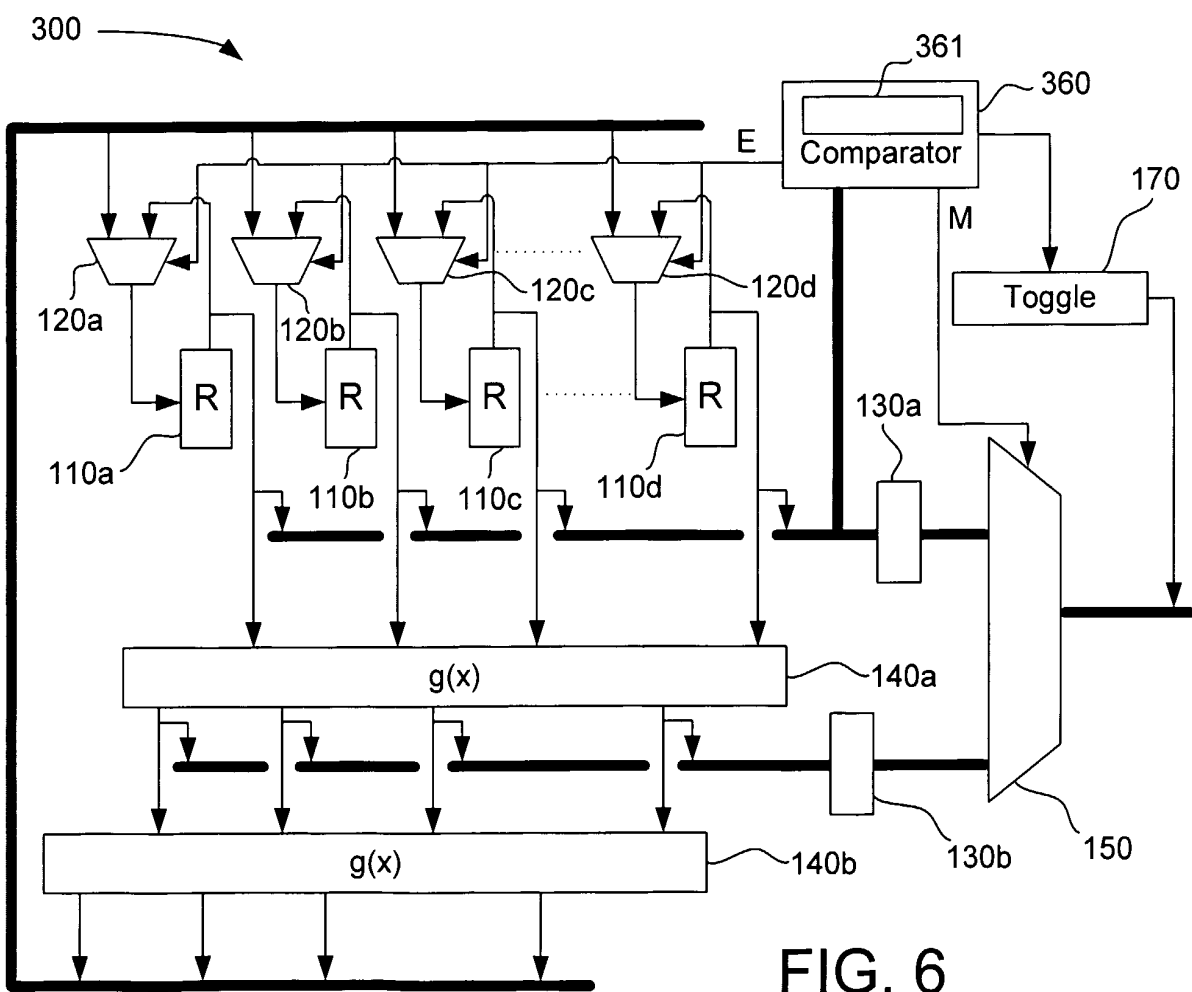

FIG. 6

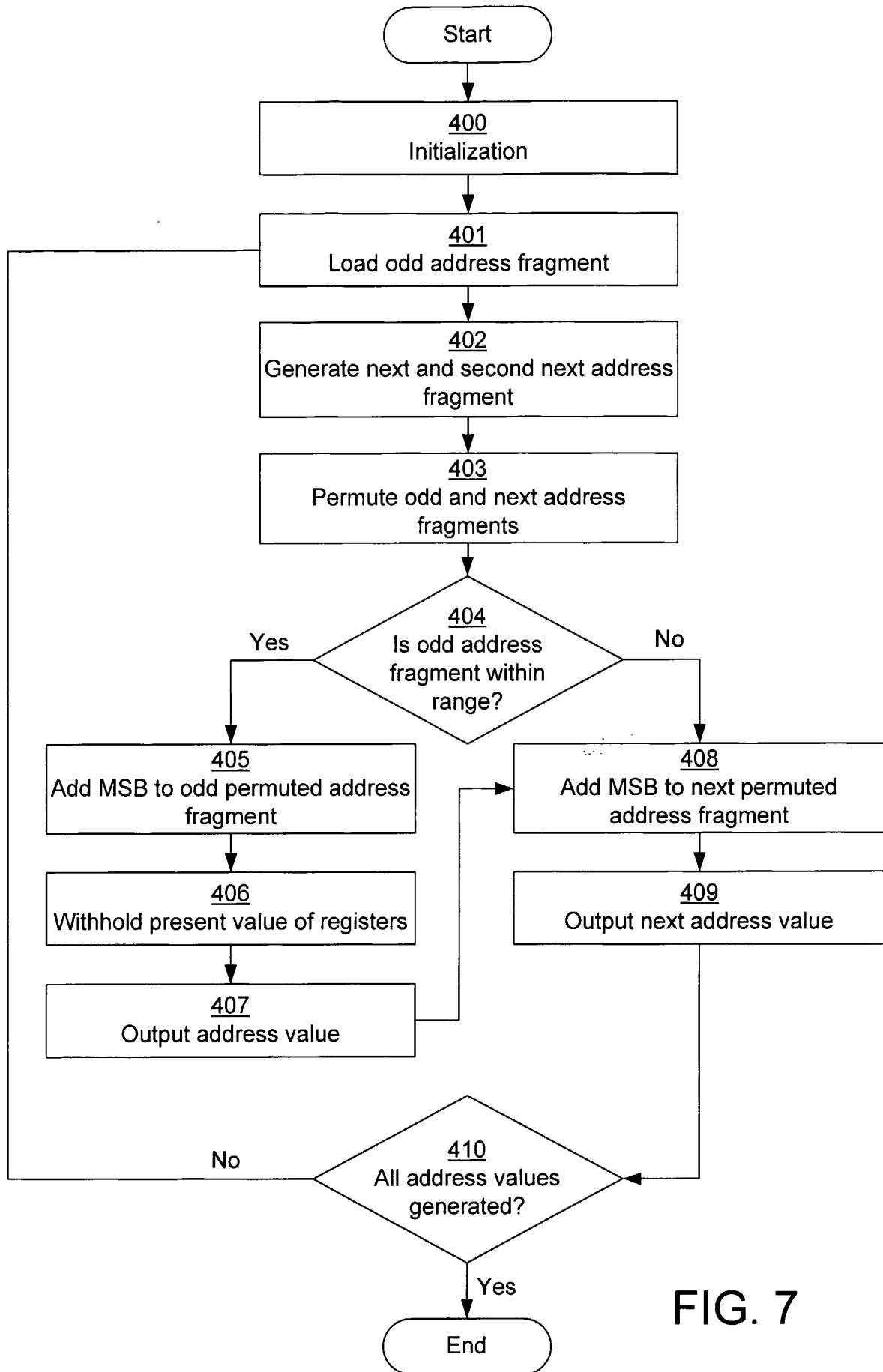

FIG. 7

INTERNATIONAL SEARCH REPORT

International Application No
PCT/EP2005/002221

A. CLASSIFICATION OF SUBJECT MATTER IPC 7 H03M13/27				
According to International Patent Classification (IPC) or to both national classification and IPC				
B. FIELDS SEARCHED				
Minimum documentation searched (classification system followed by classification symbols) IPC 7 H03M				
Documentation searched other than minimum documentation to the extent that such documents are included in the fields searched				
Electronic data base consulted during the international search (name of data base and, where practical, search terms used) EPO-Internal, WPI Data, PAJ				
C. DOCUMENTS CONSIDERED TO BE RELEVANT				
Category °	Citation of document, with indication, where appropriate, of the relevant passages	Relevant to claim No.		
X	US 6 625 234 B1 (CUI JIAN ET AL) 23 September 2003 (2003-09-23) figure 2 abstract column 3, line 29 - column 5, line 15	1-4,7, 9-14,17, 19-34		
X	US 6 314 534 B1 (ZOU QIUZHEN ET AL) 6 November 2001 (2001-11-06) cited in the application figures 2,3 abstract column 3, line 16 - line 18 column 2, line 25 - line 28 column 1, line 51 - line 63 column 3, line 57 - column 4, line 20 ----- -/--	1-34		
<table style="width:100%; border: none;"> <tr> <td style="width:50%; border: none;"> <input checked="" type="checkbox"/> Further documents are listed in the continuation of box C. </td> <td style="width:50%; border: none;"> <input checked="" type="checkbox"/> Patent family members are listed in annex. </td> </tr> </table>			<input checked="" type="checkbox"/> Further documents are listed in the continuation of box C.	<input checked="" type="checkbox"/> Patent family members are listed in annex.
<input checked="" type="checkbox"/> Further documents are listed in the continuation of box C.	<input checked="" type="checkbox"/> Patent family members are listed in annex.			
° Special categories of cited documents :				
"A" document defining the general state of the art which is not considered to be of particular relevance "E" earlier document but published on or after the international filing date "L" document which may throw doubts on priority claim(s) or which is cited to establish the publication date of another citation or other special reason (as specified) "O" document referring to an oral disclosure, use, exhibition or other means "P" document published prior to the international filing date but later than the priority date claimed	"T" later document published after the international filing date or priority date and not in conflict with the application but cited to understand the principle or theory underlying the invention "X" document of particular relevance; the claimed invention cannot be considered novel or cannot be considered to involve an inventive step when the document is taken alone "Y" document of particular relevance; the claimed invention cannot be considered to involve an inventive step when the document is combined with one or more other such documents, such combination being obvious to a person skilled in the art. "&" document member of the same patent family			
Date of the actual completion of the international search <p align="center">12 May 2005</p>	Date of mailing of the international search report <p align="center">27/05/2005</p>			
Name and mailing address of the ISA European Patent Office, P.B. 5818 Patentlaan 2 NL - 2280 HV Rijswijk Tel. (+31-70) 340-2040, Tx. 31 651 epo nl, Fax: (+31-70) 340-3016	Authorized officer <p align="center">Winkler, G</p>			

INTERNATIONAL SEARCH REPORT

International Application No
PCT/EP2005/002221

C.(Continuation) DOCUMENTS CONSIDERED TO BE RELEVANT		
Category *	Citation of document, with indication, where appropriate, of the relevant passages	Relevant to claim No.
A	WO 00/60751 A (SAMSUNG ELECTRONICS CO LTD) 12 October 2000 (2000-10-12) page 6, line 14 - line 24 -----	4
A	"Digital Video Broadcasting (DVB); Framing structure, channel coding and modulation for digital terrestrial television; ETSI EN 300 744" ETSI STANDARDS, EUROPEAN TELECOMMUNICATIONS STANDARDS INSTITUTE, SOPHIA-ANTIPO, FR, vol. BC, no. V141, January 2001 (2001-01), XP014001882 ISSN: 0000-0001 cited in the application page 18 - page 19 -----	1-34

INTERNATIONAL SEARCH REPORT

Information on patent family members

International Application No

PCT/EP2005/002221

Patent document cited in search report	Publication date	Patent family member(s)	Publication date	
US 6625234	B1	23-09-2003	BR 9916067 A	29-01-2002
			CA 2357613 A1	15-06-2000
			CN 1381095 A	20-11-2002
			DE 69909649 D1	21-08-2003
			DE 69909649 T2	04-03-2004
			EP 1138121 A1	04-10-2001
			HK 1038653 A1	10-10-2003
			WO 0035101 A1	15-06-2000
			JP 2002532939 T	02-10-2002
			MX PA01005902 A	30-08-2002
US 6314534	B1	06-11-2001	AU 4059000 A	16-10-2000
			CN 1345486 A ,C	17-04-2002
			EP 1166450 A1	02-01-2002
			JP 2002540712 T	26-11-2002
			WO 0059117 A1	05-10-2000
WO 0060751	A	12-10-2000	KR 2000066035 A	15-11-2000
			AU 746913 B2	02-05-2002
			AU 3681700 A	23-10-2000
			BR 0005569 A	06-03-2001
			CA 2332990 A1	12-10-2000
			CN 1297616 A ,C	30-05-2001
			DE 60015272 D1	02-12-2004
			DE 60015272 T2	21-04-2005
			EP 1092270 A1	18-04-2001
			JP 3447270 B2	16-09-2003
			JP 2002541711 T	03-12-2002
			WO 0060751 A1	12-10-2000
			RU 2186460 C1	27-07-2002
			US 6590951 B1	08-07-2003