



- (51) International Patent Classification:
A61B 17/00 (2006.01)
- (21) International Application Number:
PCT/IB2019/059523
- (22) International Filing Date:
06 November 2019 (06.11.2019)
- (25) Filing Language: English
- (26) Publication Language: English
- (30) Priority Data:
62/756,089 06 November 2018 (06.11.2018) US
- (72) Inventors; and
- (71) Applicants: **MORADI, Ali** [IR/IR]; Orthopedic Research Center, Department of Orthopedics, Ghaem Hospital, Ahmad Abad St., Mashhad, 9176699199 (IR). **MORADI, Morteza** [IR/IR]; Unit 3, No. 1, Namdar 13th, Alvand 16th, Ebrahimi Ave., Marzadaran St., Tehran, 1463739454 (IR). **VAHEDI, Ehsan** [IR/IR]; Orthopedic Research Center, Department of Orthopedics, Ghaem Hospital, Ahmad Abad St., Mashhad, 9176699199 (IR). **KERMANI, Saeed**

[IR/IR]; Orthopedic Research Center, Department of Orthopedics, Ghaem Hospital, Ahmad Abad St., Mashhad, 9176699199 (IR). **EBRAHIMZADEH, Mohammad Hossein** [IR/IR]; Orthopedic Research Center, Department of Orthopedics, Ghaem Hospital, Ahmad Abad St., Mashhad, 9176699199 (IR). **MOJAVER, Nahid** [IR/IR]; Orthopedic Research Center, Department of Orthopedics, Ghaem Hospital, Ahmad Abad St., Mashhad, 9176699199 (IR).

(74) Agent: **IDESAZAN ASRAFTAB**; Unit 7, Pardis building, Behboudi St., Sattarkhan, Tehran (IR).

(81) Designated States (unless otherwise indicated, for every kind of national protection available): AE, AG, AL, AM, AO, AT, AU, AZ, BA, BB, BG, BH, BN, BR, BW, BY, BZ, CA, CH, CL, CN, CO, CR, CU, CZ, DE, DJ, DK, DM, DO, DZ, EC, EE, EG, ES, FI, GB, GD, GE, GH, GM, GT, HN, HR, HU, ID, IL, IN, IR, IS, JO, JP, KE, KG, KH, KN, KP, KR, KW, KZ, LA, LC, LK, LR, LS, LU, LY, MA, MD, ME, MG, MK, MN, MW, MX, MY, MZ, NA, NG, NI, NO, NZ, OM, PA, PE, PG, PH, PL, PT, QA, RO, RS, RU, RW, SA,

(54) Title: EXTERNAL ORTHOPEDIC FIXATION DEVICE

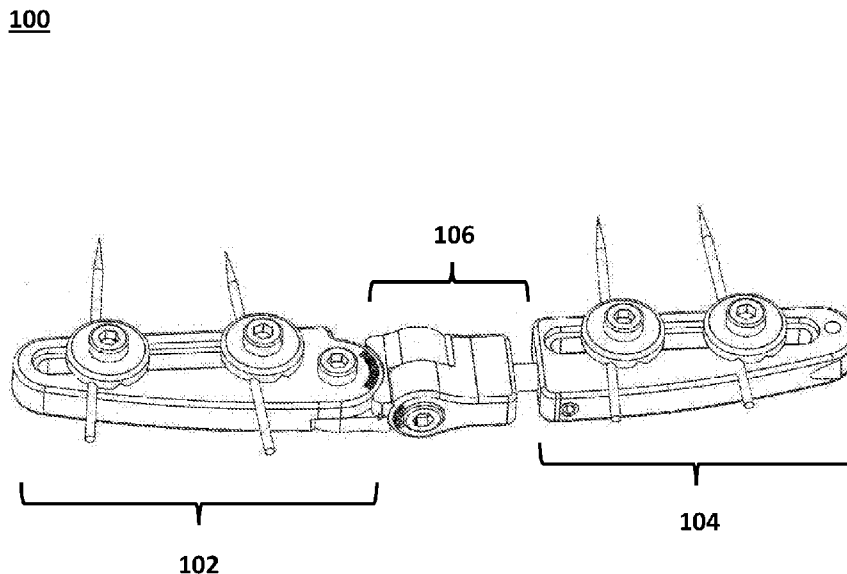

FIG. 1A

(57) Abstract: An external orthopedic fixation device. The external orthopedic fixation device includes a radius fixing member, a metacarpus fixing member, and a coupling member. The radius fixing member is configured to be secured to a radius bone of a patient. The metacarpus fixing member is configured to be secured to a metacarpus bone of the patient. The coupling member is disposed between the radius fixing member and the metacarpus fixing member. The coupling member is configured to connect the radius fixing member and the metacarpus fixing member.



SC, SD, SE, SG, SK, SL, SM, ST, SV, SY, TH, TJ, TM, TN,
TR, TT, TZ, UA, UG, US, UZ, VC, VN, ZA, ZM, ZW.

- (84) Designated States** (*unless otherwise indicated, for every kind of regional protection available*): ARIPO (BW, GH, GM, KE, LR, LS, MW, MZ, NA, RW, SD, SL, ST, SZ, TZ, UG, ZM, ZW), Eurasian (AM, AZ, BY, KG, KZ, RU, TJ, TM), European (AL, AT, BE, BG, CH, CY, CZ, DE, DK, EE, ES, FI, FR, GB, GR, HR, HU, IE, IS, IT, LT, LU, LV, MC, MK, MT, NL, NO, PL, PT, RO, RS, SE, SI, SK, SM, TR), OAPI (BF, BJ, CF, CG, CI, CM, GA, GN, GQ, GW, KM, ML, MR, NE, SN, TD, TG).

Published:

- *with international search report (Art. 21(3))*

EXTERNAL ORTHOPEDIC FIXATION DEVICE

TECHNICAL FIELD

[0001] The present disclosure generally relates to orthopedics, and particularly to orthopedic devices, and more particularly, to an external orthopedic fixation device for repairing fractures and dislocations of a distal radius of a patient.

BACKGROUND ART

[0002] Colle's fracture and distal radius fracture are common injuries among adults, including middle-aged to elderly individuals who suffer from osteoporosis as well as younger adults who suffer falls during sports, motor vehicle accidents, or other vigorous activities. A colle's fracture is a fracture of a radius, i.e., a forearm bone on a thumb side. A distal radius fracture typically occurs when one begins to fall and extends one's hand as a reflex to lessen a force of hitting the ground. The fall may produce a sudden impact of a body weight on a heel of a hand which may result in a fracture of a radius bone just above a wrist joint with or without an associated wrist joint injury.

[0003] Realignment and setting of bones crushed by a Colle's fracture or a distal radius fracture are typically performed with an aid of an external fixator or fixation device, which may be a mechanically adjustable splint that may be mounted externally to a forearm and a hand through percutaneous pins or screws that may secure the device to bones on either side of a fracture site. External fixators may be designed in such a way that permit initial alignment of a fracture fragments and then stabilize fragments and damaged soft tissue as they heal. Furthermore, external fixators may be designed in such a way that provides a facility for a surgeon to allow him/her to exert a tensile force to a radius bone of a patient. In order to heal a Colle's fracture

or a distal radius fracture, a controllable tensile force may be needed to be applied to a radius bone along an axis perpendicular to a fracture surface. But, typical external fixators or fixation devices fail to provide a facility for a surgeon to allow him/her to exert a controllable tensile force along an axis perpendicular to a fracture surface. There is, therefore, a need for an external
5 fixator that enables a surgeon to achieve alignment of a fracture and also apply a controllable tensile force to a radius bone along an axis perpendicular to a fracture surface.

SUMMARY OF THE DISCLOSURE

[0004] This summary is intended to provide an overview of the subject matter of the present
10 disclosure and is not intended to identify essential elements or key elements of the subject matter, nor is it intended to be used to determine the scope of the claimed implementations. The proper scope of the present disclosure may be ascertained from the claims set forth below in view of the detailed description below and the drawings.

[0005] In one general aspect, the present disclosure describes an exemplary external orthopedic
15 device. An exemplary external orthopedic device may include a radius fixing member, a metacarpus fixing member, and a coupling member. In an exemplary embodiment, the radius fixing member may be configured to be secured to a radius bone of a patient. In an exemplary embodiment, the metacarpus fixing member may be configured to be secured to a metacarpus bone of the patient.

[0006] In an exemplary embodiment, the coupling member may be disposed between the
20 radius fixing member and the metacarpus fixing member. In an exemplary embodiment, the coupling member may be configured to connect the radius fixing member and the metacarpus fixing member.

[0007] In an exemplary embodiment, the coupling member may include a radius coupling element, and a metacarpus coupling element. In an exemplary embodiment, the radius coupling element may be disposed between the metacarpus fixing member and the radius coupling element. In an exemplary embodiment, the metacarpus coupling element may be connected to
5 the metacarpus fixing member and the radius coupling element.

[0008] In an exemplary embodiment, the metacarpus coupling element may be configured to rotate around a second axis. In an exemplary embodiment, the second axis may be fixed to the radius coupling element. In an exemplary embodiment, the coupling member may be configured to allow rotational movements of the radius fixing member around the first axis and
10 the second axis.

[0010] In an exemplary embodiment, the metacarpus fixing member may include an adjusting hole. In an exemplary embodiment, the metacarpus coupling element may include a first adjusting rod associated with the adjusting hole, the first adjusting rod disposed slidably inside a first side of the adjusting hole.

15 [0011] In an exemplary embodiment, a distance between the radius fixing member and the metacarpus fixing member may be configured to be changed responsive to linear movement of the first adjusting rod inside the adjusting hole and along a third axis.

[0012] In an exemplary embodiment, the external orthopedic fixation device may further include a force adjusting mechanism configured to exert a tensile force between the radius
20 fixing member and the metacarpus fixing member through urging the first adjusting rod to move linearly inside the adjusting hole and along the third axis.

[0013] In an exemplary embodiment, the force adjusting mechanism may include a second adjusting rod including a second hollow cylindrical section. In an exemplary embodiment, the second adjusting rod may be configured to be inserted inside a second side of the adjusting

hole and also may be configured to urge the first adjusting rod to move linearly inside the adjusting hole and along the third axis.

[0014] In an exemplary embodiment, the force adjusting mechanism may further include a pushing member and a spring. In an exemplary embodiment, the pushing member may include a first hollow cylindrical section. In an exemplary embodiment, the first hollow cylindrical section may be disposed slidably inside the second hollow cylindrical section. In an exemplary embodiment, the spring may be disposed between the second adjusting rod and the pushing member. In an exemplary embodiment, the spring may be disposed inside the first hollow cylindrical section and the second hollow cylindrical section.

[0015] In an exemplary embodiment, responsive to linear movement of the pushing member inside the second hollow cylindrical section and along a fourth axis, the spring may be configured to compress, and to thereby, urge the second adjusting rod to move along the fourth axis.

[0016] In an exemplary embodiment, the force adjusting mechanism may further include a shell. In an exemplary embodiment, the second adjusting rod and the pushing member may be disposed slidably inside the shell. In an exemplary embodiment, responsive to linear movement of the first hollow cylindrical section of pushing member inside the second hollow cylindrical section and along the fourth axis, the spring may be configured to compress, and to thereby urge the second adjusting rod to move along the fourth axis and inside the shell.

[0017] In an exemplary embodiment, the first axis may be perpendicular to the second axis. In an exemplary embodiment, the second axis may be perpendicular to the third axis. In an exemplary embodiment, the fourth axis may be the same as the third axis.

[0018] In an exemplary embodiment, the shell may include a slot on an outermost surface of the shell. In an exemplary embodiment, the slot may be configured to provide a view of the pushing member and the second adjusting rod to a surgeon.

5 [0019] In an exemplary embodiment, the coupling member may further include a first locking nut and a second locking nut. In an exemplary embodiment, a first internally threaded section of the first locking nut may correspond to a first externally threaded section of the first attaching rod. In an exemplary embodiment, the first internally threaded section of the first locking nut may be configured to be meshed with the first externally threaded section of the first attaching rod.

10 [0020] In an exemplary embodiment, responsive to fastening the first locking nut onto the first attaching rod, the radius coupling element may be configured to be prevented from rotating around the first axis and, to thereby, radius coupling element may be fixed relative to radius fixing member.

15 [0021] In an exemplary embodiment, a second internally threaded section of the second locking nut may correspond to a second externally threaded section of the second attaching rod. In an exemplary embodiment, the second internally threaded section of the second locking nut may be configured to be meshed with the second externally threaded section of the second attaching rod.

20 [0022] In an exemplary embodiment, responsive to fastening the second locking nut onto the second attaching rod, the metacarpus coupling element may be configured to be prevented from rotating around the second axis and, to thereby, metacarpus coupling element may be fixed relative to radius coupling element.

[0023] In an exemplary embodiment, the coupling member may further include a locking screw associated with the first adjusting rod. In an exemplary embodiment, responsive to

fastening the locking screw, a friction between the locking screw and the first adjusting rod may be configured to be increased, and to thereby, prevent first adjusting rod from linear movement along the third axis, and to thereby, fix the metacarpus coupling element relative to metacarpus fixing member.

5

BRIEF DESCRIPTION OF THE DRAWINGS

[0024] The drawing figures depict one or more implementations in accord with the present teachings, by way of example only, not by way of limitation. In the figures, like reference numerals refer to the same or similar elements.

10 **[0025] FIG. 1A** illustrates a perspective view of an exemplary external orthopedic fixation device, consistent with one or more exemplary embodiments of the present disclosure.

[0026] FIG. 1B illustrates a top view of an external orthopedic fixation device, consistent with one or more exemplary embodiments of the present disclosure.

15 **[0027] FIG. 1C** shows a side view of an external orthopedic fixation device, consistent with one or more exemplary embodiments of the present disclosure.

[0028] FIG. 1D illustrates an exemplary scenario when external orthopedic fixation device is secured to a hand of a patient, consistent with one or more exemplary embodiments of the present disclosure.

20 **[0029] FIG. 2A** illustrates an exploded view of an external orthopedic fixation device, consistent with one or more exemplary embodiments of the present disclosure.

[0030] FIG. 2B illustrates a perspective view of a coupling member, consistent with one or more exemplary embodiments of the present disclosure.

[0031] FIG. 3A illustrates an external orthopedic fixation device, consistent with one or more exemplary embodiments of the present disclosure.

[0032] FIG. 3B illustrates a force adjusting mechanism, consistent with one or more exemplary embodiments of the present disclosure.

[0033] FIG. 3C illustrates a sectional view of a force adjusting mechanism, consistent with one or more exemplary embodiments of the present disclosure.

5 [0034] FIG. 3D illustrates an exploded view of a force adjusting mechanism, consistent with one or more exemplary embodiments of the present disclosure.

[0035] FIG. 3E illustrates a sectional view of a second adjusting rod, consistent with one or more exemplary embodiments of the present disclosure.

10 [0036] FIG. 3F illustrates a sectional view of a pushing member, consistent with one or more exemplary embodiments of the present disclosure.

[0037] FIG. 3G illustrates a side view of an adjusting mechanism in a scenario when pushing member is free and not moved along fourth axis.

15 [0038] FIG. 3H illustrates a side view of an adjusting mechanism in a scenario when pushing member is moved along fourth axis, consistent with one or more exemplary embodiments of the present disclosure.

DESCRIPTION OF EMBODIMENTS

20 [0039] In the following detailed description, numerous specific details are set forth by way of examples in order to provide a thorough understanding of the relevant teachings. However, it should be apparent that the present teachings may be practiced without such details. In other instances, well known methods, procedures, components, and/or circuitry have been described at a relatively high-level, without detail, in order to avoid unnecessarily obscuring aspects of the present teachings.

[0040] The following detailed description is presented to enable a person skilled in the art to make and use the methods and devices disclosed in exemplary embodiments of the present disclosure. For purposes of explanation, specific nomenclature is set forth to provide a thorough understanding of the present disclosure. However, it will be apparent to one skilled in the art that these specific details are not required to practice the disclosed exemplary embodiments. Descriptions of specific exemplary embodiments are provided only as representative examples. Various modifications to the exemplary implementations will be readily apparent to one skilled in the art, and the general principles defined herein may be applied to other implementations and applications without departing from the scope of the present disclosure. The present disclosure is not intended to be limited to the implementations shown but is to be accorded the widest possible scope consistent with the principles and features disclosed herein.

[0041] Herein is disclosed an exemplary orthopedic device for repairing fractures and dislocations of a fractured distal radius of a patient. An exemplary orthopedic device may include a radius fixing member and a metacarpus fixing member. The radius fixing member may be secured to a radius of a patient and the metacarpus fixing member may be secured to a metacarpus of the patient. The radius fixing member and the metacarpus fixing member may be connected to each other utilizing a coupling member which may allow the radius fixing member and the metacarpus fixing member to rotate and move linearly in order to provide three degrees of freedom for the exemplary orthopedic device. Furthermore, an exemplary orthopedic device may include a force adjusting mechanism which may be used by a surgeon to exert a controllable tensile force between a radius and a metacarpus of a patient and along an axis perpendicular to a fracture surface.

[0042] **FIG. 1A** shows a perspective view of an exemplary external orthopedic fixation device **100**, consistent with one or more exemplary embodiments of the present disclosure. **FIG. 1B**

shows a top view of external orthopedic fixation device **100**, consistent with one or more exemplary embodiments of the present disclosure. **FIG. 1C** shows a side view of external orthopedic fixation device **100**, consistent with one or more exemplary embodiments of the present disclosure. As shown in **FIG. 1A**, **FIG. 1B**, and **FIG. 1C**, in an exemplary embodiment, external orthopedic fixation device **100** may include a radius fixing member **102** and a metacarpus fixing member **104**. **FIG. 1D** shows an exemplary scenario when external orthopedic fixation device **100** is secured to a hand of a patient, consistent with one or more exemplary embodiments of the present disclosure. As shown in **FIG. 1D**, in an exemplary embodiment, radius fixing member **102** may be secured to a radius bone **120** of a patient. In an exemplary embodiment, securing radius fixing member **102** to radius bone **120** of the patient may refer to attaching radius fixing member **102** to radius bone **120** in such a way that radius fixing member **102** becomes fixed relative to radius bone **120**. In an exemplary embodiment, radius fixing member **102** may be secured to radius fixing member **102** by utilizing a first plurality of bone pins.

[0043] In an exemplary embodiment, the first plurality of bone pins may include a first bone pin **122a** and a second bone pin **122b**. In an exemplary embodiment, a distal end of first bone pin **122a** and a distal end of second bone pin **122b** may be affixed into radius bone **120**. In an exemplary embodiment, a proximal end of first bone pin **122a** and a proximal end of second bone pin **122b** may be secured to radius fixing member **102**. In an exemplary embodiment, the proximal end of second bone pin **122b** may be secured to radius fixing member **102** by utilizing a first clamp mechanism **124**. In an exemplary embodiment, first clamp mechanism **124** may include a first fastening screw **1242**. In an exemplary embodiment, the proximal end of second bone pin **122b** may be disposed between first fastening screw **1242** and radius fixing member

102, and by fastening first fastening screw **1242**, the proximal end of second bone pin **122b** may be secured to radius fixing member **102**.

[0044] In an exemplary embodiment, metacarpus fixing member **104** may be secured to a metacarpus bone **140** of the patient. In an exemplary embodiment, securing metacarpus fixing member **104** to metacarpus bone **140** of the patient may refer to attaching metacarpus fixing member **104** to metacarpus bone **140** in such a way that metacarpus fixing member **104** is fixed relative to metacarpus bone **140**. In an exemplary embodiment, metacarpus fixing member **104** may be secured to metacarpus bone **140** by utilizing a second plurality of bone pins. In an exemplary embodiment, the second plurality of bone pins may include a third bone pin **142a** and a fourth bone pin **142b**. In an exemplary embodiment, a distal end of third bone pin **142a** and a distal end of fourth bone pin **142b** may be affixed into metacarpus bone **140**. In an exemplary embodiment, a proximal end of third bone pin **142a** and a proximal end of fourth bone pin **142b** may be secured to metacarpus fixing member **104**.

[0045] In an exemplary embodiment, the proximal end of fourth bone pin **142b** may be secured to metacarpus fixing member **104** by utilizing a second clamp mechanism **144**. In an exemplary embodiment, second clamp mechanism **144** may include a second fastening screw **1442**. In an exemplary embodiment, the proximal end of second bone pin **142b** may be disposed between second fastening screw **1442** and metacarpus fixing member **104**, and by fastening second fastening screw **1442**, the proximal end of fourth bone pin **142b** may be secured to metacarpus fixing member **104**. In an exemplary embodiment, external orthopedic fixation device **100** may further include a coupling member **106**. In an exemplary embodiment, coupling member **106** may be configured to connect radius fixing member **102** and metacarpus fixing member **104**.

[0046] FIG. 2A shows an exploded view of external orthopedic fixation device **100**, consistent with one or more exemplary embodiments of the present disclosure. FIG. 2B shows a perspective view of coupling member **106**, consistent with one or more exemplary embodiments of the present disclosure. As shown in FIG. 2A and FIG. 2B, in an exemplary embodiment, coupling member **106** may include a radius coupling element **202**. In an exemplary embodiment, radius coupling element **202** may be connected to radius fixing member **102** in such a way that radius coupling element **202** be able to rotate around a first axis **222**. In an exemplary embodiment, first axis **222** may be associated with radius fixing member **102**. In fact, in an exemplary embodiment, first axis **222** may be fixed to radius fixing member **102**. In an exemplary embodiment, radius coupling element **202** may include a first attaching rod **224**. In an exemplary embodiment, first attaching rod **224** may be disposed freely inside a first rod receiving hole **232** of radius fixing member **102**. In an exemplary embodiment, disposing first attaching rod **224** freely inside first rod receiving hole **232** may refer to an exemplary scenario in which an external diameter of first attaching rod **224** is smaller than an internal diameter of first rod receiving hole **232**. In an exemplary embodiment, the difference between the external diameter of first attaching rod **224** and the internal diameter of first rod receiving hole **232** may allow first attaching rod **224** to rotate freely inside first rod receiving hole **232**.

[0047] In an exemplary embodiment, as shown in FIG. 2A and FIG. 2B, coupling member **106** may further include a metacarpus coupling element **204**. In an exemplary embodiment, metacarpus coupling element **204** may be connected to radius coupling element **202** in such a way that metacarpus coupling element **204** may be able to rotate around a second axis **242**. In an exemplary embodiment, second axis **242** may be associated with radius coupling element **202**. In an exemplary embodiment, radius coupling element **202** may include a second attaching

rod **226**. In an exemplary embodiment, second attaching rod **226** may be disposed freely inside a second rod receiving hole **252** of metacarpus coupling element **204**. In an exemplary embodiment, disposing second attaching rod **226** freely inside second rod receiving hole **252** may refer to an exemplary scenario in which an external diameter of second attaching rod **226** is smaller than an internal diameter of second rod receiving hole **252**. In an exemplary embodiment, the difference between the external diameter of second attaching rod **226** and the internal diameter of second rod receiving hole **252** may allow second attaching rod **226** to rotate freely inside rod receiving hole **232**.

[0048] In an exemplary embodiment, coupling member **106** may further include a first locking nut **272** associated with first attaching rod **224**. In an exemplary embodiment, first attaching rod **224** may include a first externally threaded section corresponds to a first internally threaded section of first locking nut **272**. In an exemplary embodiment, first locking nut **272** and first attaching rod **224** may act as a nut and screw mechanism. In an exemplary embodiment, responsive to fastening first locking nut **272**, radius coupling element **202** may be prevented from rotating around first axis **222** and, consequently, radius coupling element **202** may be fixed relative to radius fixing member **102**.

[0049] In an exemplary embodiment, coupling member **106** may further include a second locking nut **273** associated with second attaching rod **226**. In an exemplary embodiment, second attaching rod **226** may include a second externally threaded section corresponds to a second internally threaded section of second locking nut **273**. In an exemplary embodiment, second locking nut **273** and second attaching rod **226** may act as a nut and screw mechanism. In an exemplary embodiment, responsive to fastening second locking nut **272**, metacarpus coupling element **204** may be prevented from rotating around second axis **222** and,

consequently, metacarpus coupling element **204** may be fixed relative to radius coupling element **202**.

[0050] In an exemplary embodiment, metacarpus coupling element **204** may further include a first adjusting rod **244**. In an exemplary embodiment, first adjusting rod **244** may be disposed
5 slidably inside an adjusting hole **254** of metacarpus fixing member **104** from a first side **2542** of adjusting hole **254**. In an exemplary embodiment, disposing first adjusting rod **244** slidably inside adjusting hole **254** may refer to disposing first adjusting rod **244** inside adjusting hole **254** in such a way that first adjusting rod **244** is able to move linearly inside adjusting hole **254** and along a third axis **262**. In an exemplary embodiment, third axis **262** may be associated with
10 metacarpus fixing member **104**. In an exemplary embodiment, third axis **262** may be the same as a main longitudinal axis of adjusting hole **254**. In an exemplary embodiment, disposing first adjusting rod **244** slidably inside adjusting hole **254** may allow metacarpus fixing member **104** to move linearly along third axis **262** and relative to coupling member **106**.

[0051] In an exemplary embodiment, coupling member **106** may further include a locking
15 screw **274** associated with first adjusting rod **244**. In an exemplary embodiment, responsive to fastening locking screw **274**, first adjusting rod **244** may be prevented from linear movement along third axis **262** and, in fact, metacarpus coupling element **204** may be fixed relative to metacarpus fixing member **104**.

[0052] **FIG. 3A** shows external orthopedic fixation device **100**, consistent with one or more
20 exemplary embodiments of the present disclosure. As shown in **FIG. 3A**, in an exemplary embodiment, external orthopedic fixation device **100** may further include a force adjusting mechanism **300**. In an exemplary embodiment, force adjusting mechanism **300** may be configured to exert a tensile force between radius fixing member **102** and metacarpus fixing member **104**. **FIG. 3B** shows force adjusting mechanism **300**, consistent with one or more

exemplary embodiments of the present disclosure. In an exemplary embodiment, force adjusting mechanism **300** may include a second adjusting rod **302**.

[0053] In an exemplary embodiment, second adjusting rod **302** may be configured to be inserted inside a second side **2544** of adjusting hole **254** and urge first adjusting rod **244** to move linearly inside adjusting hole **254** and along third axis **262**. In an exemplary embodiment, second adjusting rod **302** may urge first adjusting rod **244** to move along third axis **262** and in a direction **310**. In an exemplary embodiment, moving first adjusting rod **244** inside adjusting hole **254** and in direction **310** may increase a distance between radius fixing member **102** and metacarpus fixing member **104**. Furthermore, in an exemplary embodiment, moving first adjusting rod **244** inside adjusting hole **254** and in direction **310** may exert a tensile force between radius fixing member **102** and metacarpus fixing member **104**. In an exemplary embodiment, it may be understood that the tensile force between radius fixing member **102** and metacarpus fixing member **104** may directly be applied between radius bone **120** and metacarpus bone **140**.

[0054] **FIG. 3C** shows a sectional view of force adjusting mechanism **300**, consistent with one or more exemplary embodiments of the present disclosure. **FIG. 3D** shows an exploded view of force adjusting mechanism **300**, consistent with one or more exemplary embodiments of the present disclosure. As shown in **FIG. 3C** and **FIG. 3D**, in an exemplary embodiment, force adjusting mechanism **300** may further include a pushing member **304** and a spring **306**. **FIG. 3E** shows a sectional view of second adjusting rod **302**, consistent with one or more exemplary embodiments of the present disclosure. **FIG. 3F** shows a sectional view of pushing member **304**, consistent with one or more exemplary embodiments of the present disclosure.

[0055] Referring back to **FIG. 3C**, in an exemplary embodiment, a first hollow cylindrical section **342** of pushing member **304** may be disposed slidably inside a second hollow

cylindrical section **322** of second adjusting rod **302**. Furthermore, spring **306** may be disposed between second adjusting rod **302** and pushing member **304** and inside first hollow cylindrical section **342** and second hollow cylindrical section **322**. In an exemplary embodiment, when pushing member **304** is moved along a fourth axis **330** and in a direction **350**, it may compress
5 spring **306**, and to thereby, may urge second adjusting rod **302** to move along fourth axis **330** and in direction **350**. In an exemplary embodiment, force adjusting mechanism **300** may further include a shell **308**. In an exemplary embodiment, second adjusting rod **302** and pushing member **304** may be disposed slidably inside shell **308**. In an exemplary embodiment, shell **308** may include a slot **382**.

10 **[0056]** In an exemplary embodiment, slot **382** may provide a facility for a surgeon to see the amounts which second adjusting rod **302** and pushing member **304** are moved along fourth axis **330** and in direction **350**. In an exemplary embodiment, a difference between an amount which pushing member **304** is moved along fourth axis **330** and in direction **350** and an amount which
15 second adjusting rod **302** is moved along fourth axis **330** and in direction **350** may be the same as an amount which spring **306** is compressed. In an exemplary embodiment, it may be understood that, the amount which spring **306** is compressed may be an indication for the tensile force between radius fixing member **102** and metacarpus fixing member **104**. Consequently, in an exemplary embodiment, slot **382** may act as a force indicator which
20 provide a facility for a surgeon to calculate the tensile force between radius fixing member **102** and metacarpus fixing member **104**.

[0057] In an exemplary embodiment, it may be understood that the tensile force between radius fixing member **102** and metacarpus fixing member **104** may be a force along third axis **262**. In an exemplary embodiment, a tensile force along third axis **262** may refer to a force which is able to pull radius fixing member **102** in direction of third axis **262**. A surgeon may

rotate metacarpus fixing member **104** around first axis **222** and second axis **242** to change a direction of third axis **262** in space. For example, a surgeon may rotate metacarpus fixing member **104** around first axis **222** and second axis **242** to set third axis **262** along an axis perpendicular to a fracture plane or a distal radius articular plane. Consequently, the tensile force between radius fixing member **102** and metacarpus fixing member **104** which may be applied between radius bone **120** and metacarpus bone **140** may be a tensile force along the axis perpendicular to the fracture plane or the distal radius articular plane.

[0058] **FIG. 3G** shows a side view of adjusting mechanism **300** in a scenario when pushing member **304** is free and not moved along fourth axis **330**. **FIG. 3H** shows a side view of adjusting mechanism **300** in a scenario when pushing member **304** is moved along fourth axis **330** and in direction **350**, consistent with one or more exemplary embodiments of the present disclosure. As may be seen in **FIG. 3G**, in an exemplary embodiment, when pushing member **304** is moved along fourth axis **330** and in direction **350**, pushing member **304** may be moved by a first amount **344** and second adjusting rod **302** may be moved by a second amount **324**. In an exemplary embodiment, it may be understood that a difference between first amount **344** and second amount **324** may be equal to a compression amount of spring **306**. Furthermore, it may be understood that a surgeon, utilizing a compression amount of spring **306**, may be able to calculate a tensile force applied by external orthopedic fixation device **100** between radius bone **120** and metacarpus bone **140**. Hence, disclosed external orthopedic fixation device **100** may provide a facility for a surgeon to make him/her able to exert a controllable tensile force between a radius bone of a patient and a metacarpus bone of a patient. In an exemplary embodiment, exerting a controllable tensile force may refer to exerting a tensile force in a predetermined direction and by a predetermined magnitude.

[0059] While the foregoing has described what may be considered to be the best mode and/or other examples, it is understood that various modifications may be made therein and that the subject matter disclosed herein may be implemented in various forms and examples, and that the teachings may be applied in numerous applications, only some of which have been described herein. It is intended by the following claims to claim any and all applications, modifications and variations that fall within the true scope of the present teachings.

[0060] Unless otherwise stated, all measurements, values, ratings, positions, magnitudes, sizes, and other specifications that are set forth in this specification, including in the claims that follow, are approximate, not exact. They are intended to have a reasonable range that is consistent with the functions to which they relate and with what is customary in the art to which they pertain.

[0061] The scope of protection is limited solely by the claims that now follow. That scope is intended and should be interpreted to be as broad as is consistent with the ordinary meaning of the language that is used in the claims when interpreted in light of this specification and the prosecution history that follows and to encompass all structural and functional equivalents. Notwithstanding, none of the claims are intended to embrace subject matter that fails to satisfy the requirement of Sections 101, 102, or 103 of the Patent Act, nor should they be interpreted in such a way. Any unintended embracement of such subject matter is hereby disclaimed.

[0062] Except as stated immediately above, nothing that has been stated or illustrated is intended or should be interpreted to cause a dedication of any component, step, feature, object, benefit, advantage, or equivalent to the public, regardless of whether it is or is not recited in the claims.

[0063] It will be understood that the terms and expressions used herein have the ordinary meaning as is accorded to such terms and expressions with respect to their corresponding

respective areas of inquiry and study except where specific meanings have otherwise been set forth herein. Relational terms such as first and second and the like may be used solely to distinguish one entity or action from another without necessarily requiring or implying any actual such relationship or order between such entities or actions. The terms “comprises,” “comprising,” or any other variation thereof, are intended to cover a non-exclusive inclusion, such that a process, method, article, or apparatus that comprises a list of elements does not include only those elements but may include other elements not expressly listed or inherent to such process, method, article, or apparatus. An element preceded by “a” or “an” does not, without further constraints, preclude the existence of additional identical elements in the process, method, article, or apparatus that comprises the element.

[0064] The Abstract of the Disclosure is provided to allow the reader to quickly ascertain the nature of the technical disclosure. It is submitted with the understanding that it will not be used to interpret or limit the scope or meaning of the claims. In addition, in the foregoing Detailed Description, it can be seen that various features are grouped together in various implementations. This is for purposes of streamlining the disclosure, and is not to be interpreted as reflecting an intention that the claimed implementations require more features than are expressly recited in each claim. Rather, as the following claims reflect, inventive subject matter lies in less than all features of a single disclosed implementation. Thus, the following claims are hereby incorporated into the Detailed Description, with each claim standing on its own as a separately claimed subject matter.

[0065] While various implementations have been described, the description is intended to be exemplary, rather than limiting and it will be apparent to those of ordinary skill in the art that many more implementations and implementations are possible that are within the scope of the implementations. Although many possible combinations of features are shown in the

accompanying figures and discussed in this detailed description, many other combinations of the disclosed features are possible. Any feature of any implementation may be used in combination with or substituted for any other feature or element in any other implementation unless specifically restricted. Therefore, it will be understood that any of the features shown
5 and/or discussed in the present disclosure may be implemented together in any suitable combination. Accordingly, the implementations are not to be restricted except in light of the attached claims and their equivalents. Also, various modifications and changes may be made within the scope of the attached claims.

What is claimed is:

1- An external orthopedic fixation device, comprising:

a radius fixing member configured to be secured to a radius bone of a patient;

a metacarpus fixing member configured to be secured to a metacarpus bone of the patient;

and

a coupling member disposed between the radius fixing member and the metacarpus fixing member, the coupling member configured to connect the radius fixing member and the metacarpus fixing member, the coupling member comprising:

a radius coupling element connected to the radius fixing member, the radius coupling element configured to rotate around a first axis, the first axis fixed to the radius fixing member; and

a metacarpus coupling element disposed between the metacarpus fixing member and the radius coupling element, the metacarpus coupling element connected to the metacarpus fixing member and the radius coupling element, the metacarpus coupling element configured to rotate around a second axis, the second axis fixed to the radius coupling element;

wherein the coupling member is configured to allow rotational movements of the radius fixing member around the first axis and the second axis.

2- The external orthopedic fixation device of claim 1, wherein:

the metacarpus fixing member comprises an adjusting hole,

the metacarpus coupling element comprises a first adjusting rod associated with the adjusting hole, the first adjusting rod disposed slidably inside a first side of the adjusting hole, and

a distance between the radius fixing member and the metacarpus fixing member is configured to be changed responsive to linear movement of the first adjusting rod inside the adjusting hole and along a third axis.

- 3- The external orthopedic fixation device of claim 2, further comprising a force adjusting mechanism configured to exert a tensile force between the radius fixing member and the metacarpus fixing member through urging the first adjusting rod to move linearly inside the adjusting hole and along the third axis.
- 4- The external orthopedic fixation device of claim 3, wherein the force adjusting mechanism comprises a second adjusting rod comprising a second hollow cylindrical section, the second adjusting rod configured to:
 - be inserted inside a second side of the adjusting hole; and
 - urge the first adjusting rod to move linearly inside the adjusting hole and along the third axis.
- 5- The external orthopedic fixation device of claim 4, wherein the force adjusting mechanism further comprises:
 - a pushing member comprising a first hollow cylindrical section, the first hollow cylindrical section disposed slidably inside the second hollow cylindrical section; and
 - a spring disposed between the second adjusting rod and the pushing member, the spring disposed inside the first hollow cylindrical section and the second hollow cylindrical section;
 - wherein responsive to linear movement of the pushing member inside the second hollow cylindrical section and along a fourth axis, the spring is configured to compress, and to thereby, urge the second adjusting rod to move along the fourth axis.
- 6- The external orthopedic fixation device of claim 5, wherein the force adjusting mechanism further comprises a shell, the second adjusting rod and the pushing member disposed slidably inside the shell, responsive to linear movement of the first hollow cylindrical section of pushing member inside the second hollow cylindrical section and along the fourth axis, the spring is configured to compress, and to thereby urge the second adjusting rod to move along the fourth axis and inside the shell.

- 7- The external orthopedic fixation device of claim 6, wherein the first axis is perpendicular to the second axis.
- 8- The external orthopedic fixation device of claim 7, wherein the second axis is perpendicular to the third axis.
- 9- The external orthopedic fixation device of claim 8, wherein the fourth axis is the same as the third axis.
- 10- The external orthopedic device of claim 9, wherein the shell comprises a slot on an outermost surface of the shell, the slot configured to provide a view of the pushing member and the second adjusting rod to a surgeon.
- 11- The external orthopedic device of claim 10, wherein the coupling member further comprises:
 - a first locking nut, a first internally threaded section of the first locking nut corresponding to a first externally threaded section of the first attaching rod, the first internally threaded section of the first locking nut configured to be meshed with the first externally threaded section of the first attaching rod, responsive to fastening the first locking nut onto the first attaching rod, the radius coupling element configured to be prevented from rotating around the first axis and, to thereby, radius coupling element be fixed relative to radius fixing member; and
 - a second locking nut, a second internally threaded section of the second locking nut corresponding to a second externally threaded section of the second attaching rod, the second internally threaded section of the second locking nut configured to be meshed with the second externally threaded section of the second attaching rod, responsive to fastening the second locking nut onto the second attaching rod, the metacarpus coupling element configured to be prevented from rotating around the second axis and, to thereby, metacarpus coupling element be fixed relative to radius coupling element.
- 12- The external orthopedic device of claim 11, wherein the coupling member further comprises a locking screw associated with the first adjusting rod, responsive to fastening the locking screw, a friction between the locking screw and the first adjusting rod is configured to be increased, and to

thereby, prevent first adjusting rod from linear movement along the third axis, and to thereby, fix the metacarpus coupling element relative to metacarpus fixing member.

1/14

100

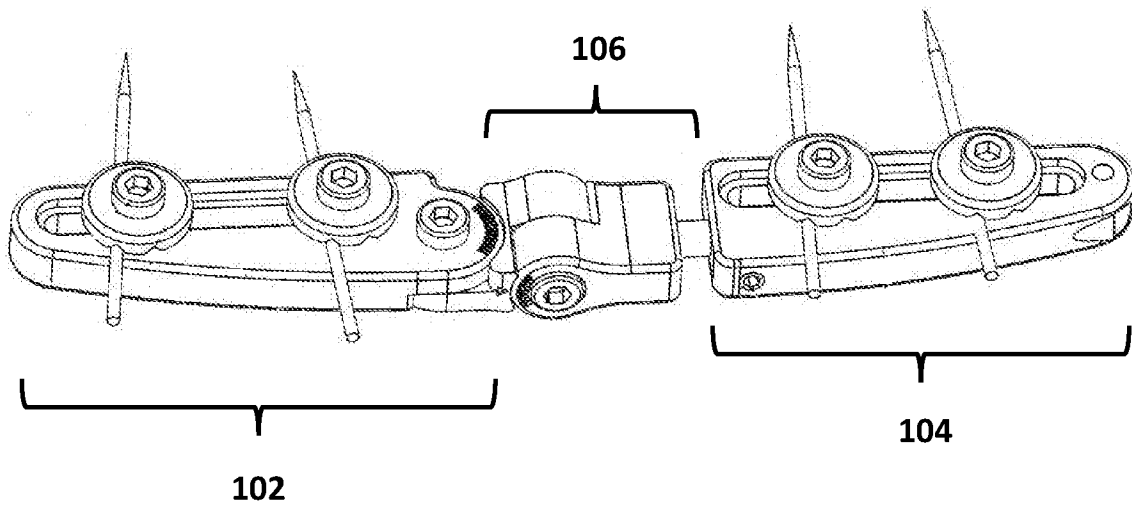

FIG. 1A

2/14

100

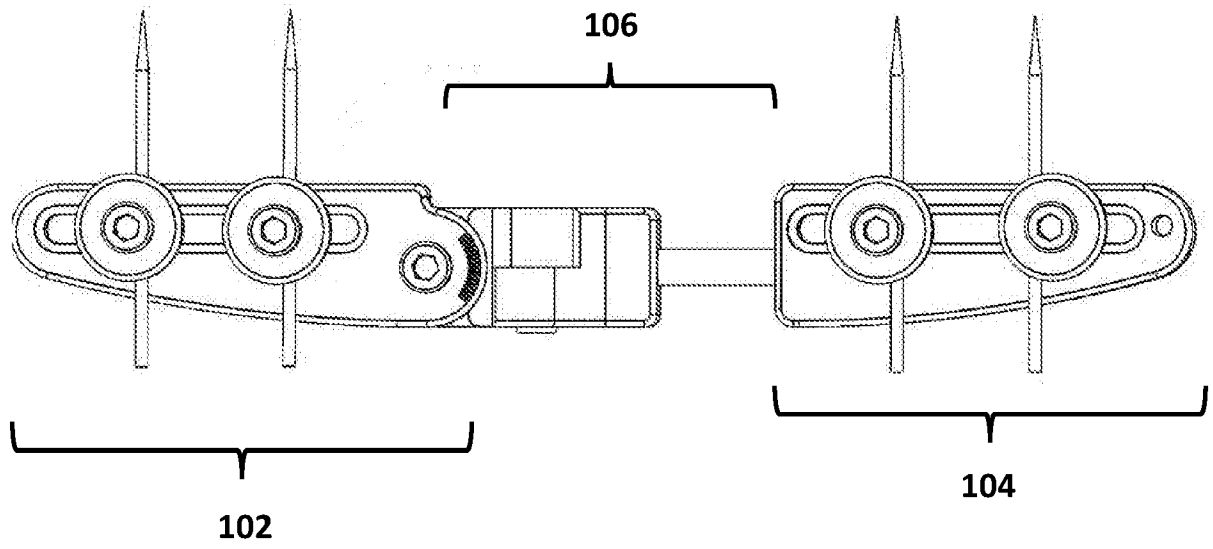

FIG. 1B

3/14

100

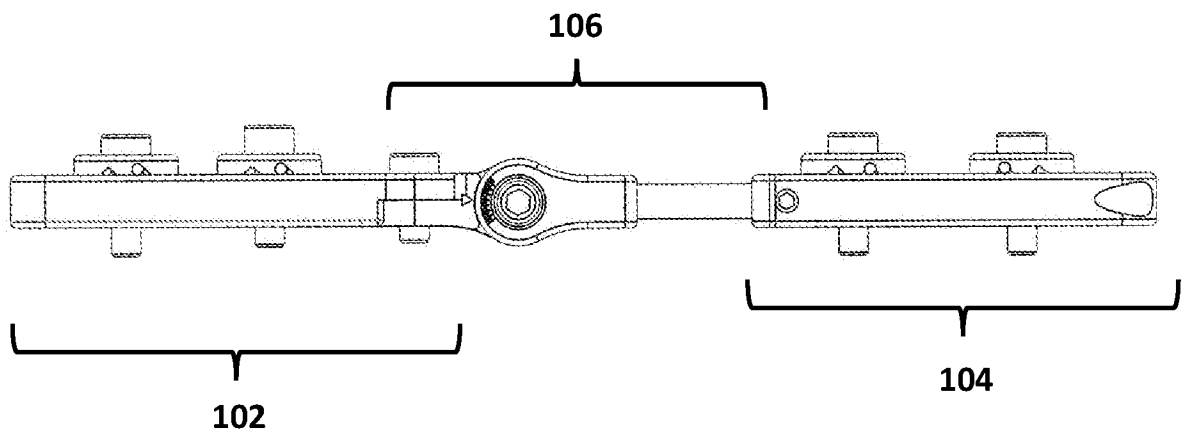

FIG. 1C

4/14

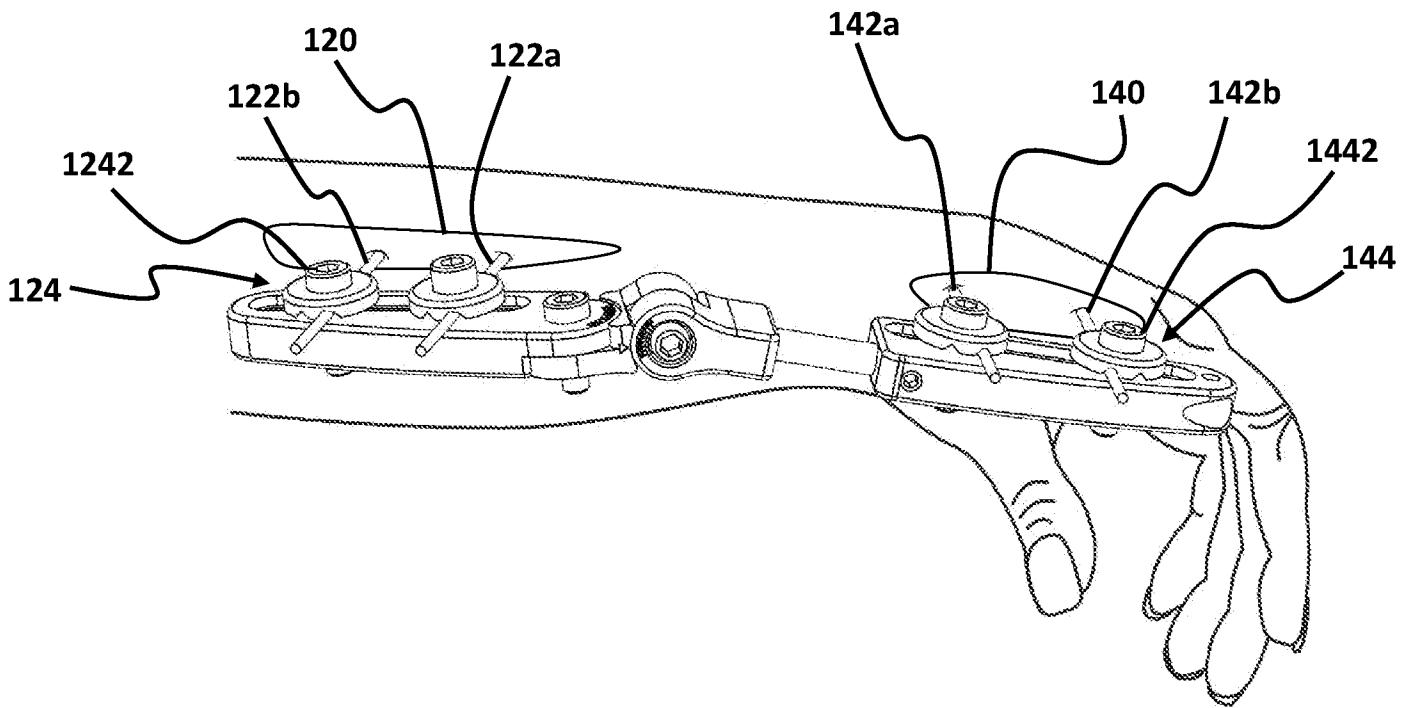

FIG. 1D

5/14

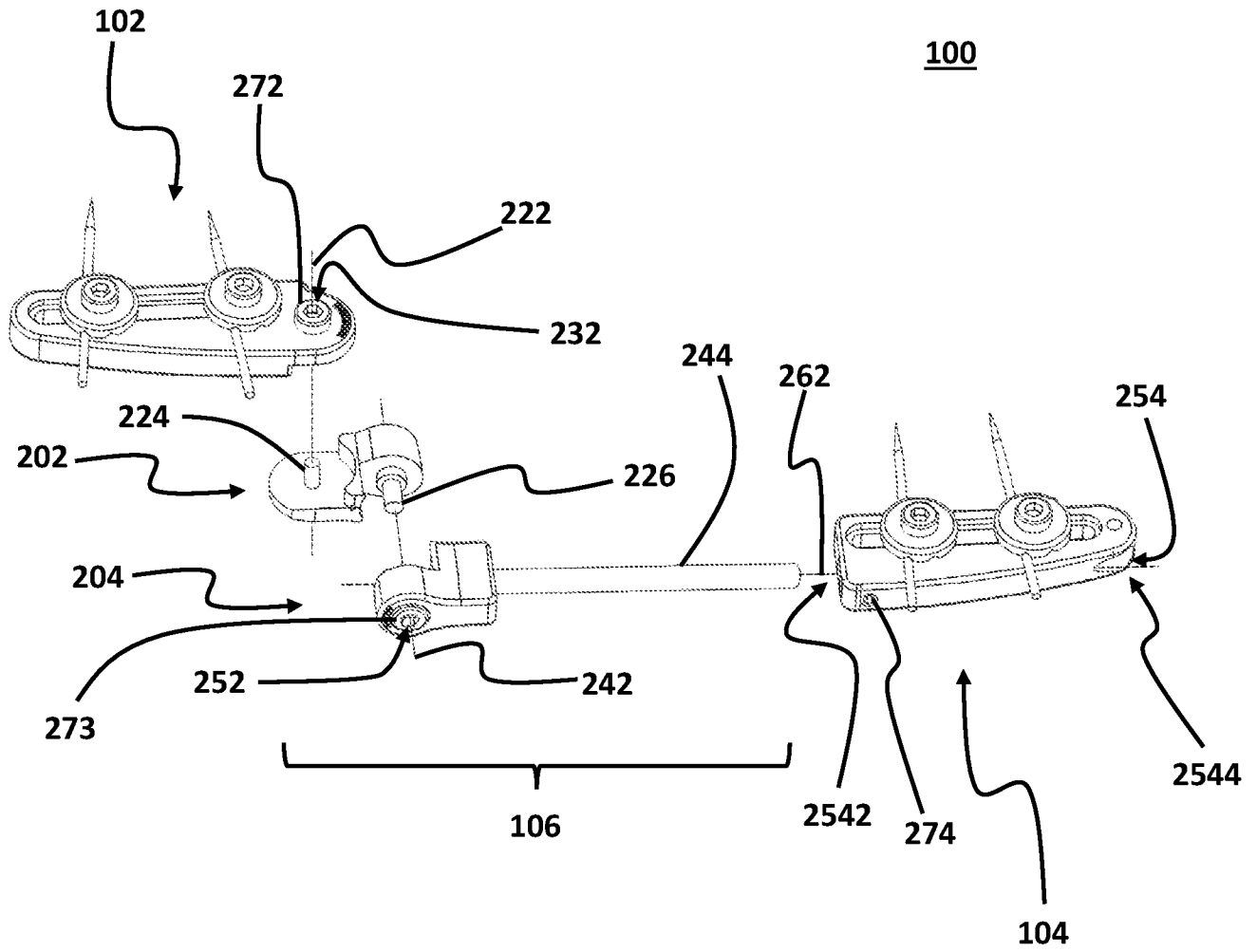

FIG. 2A

6/14

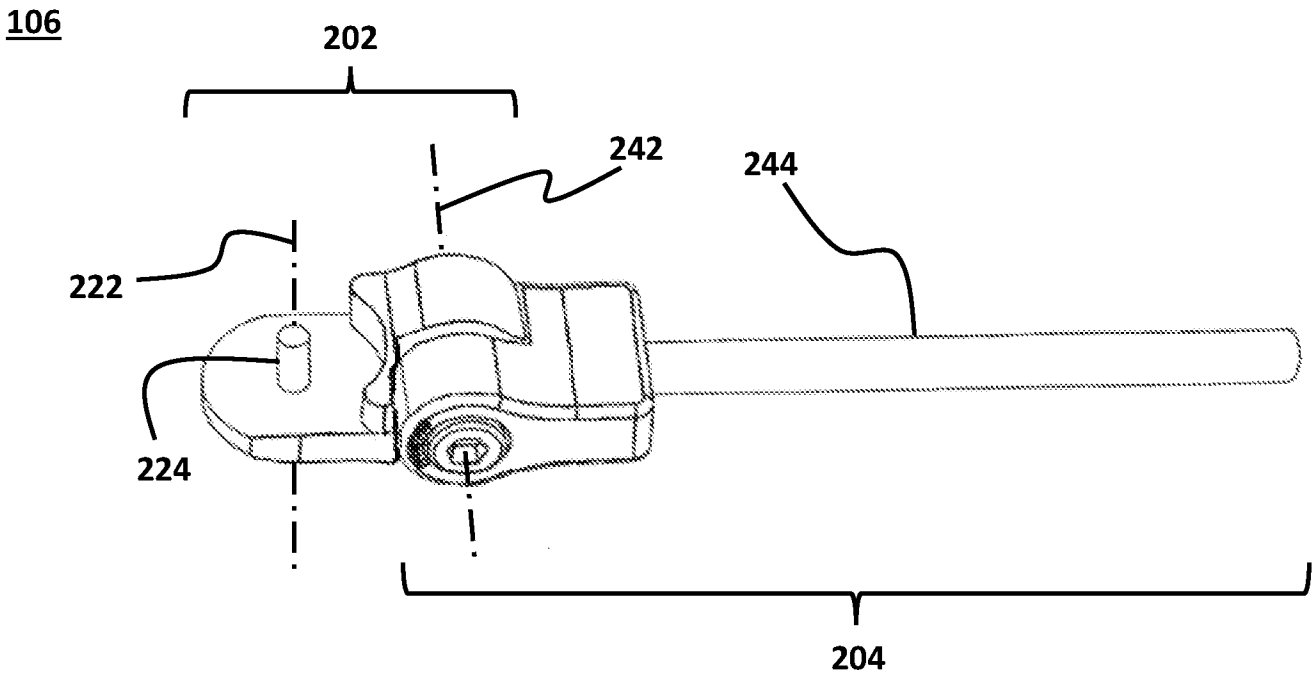

FIG. 2B

7/14

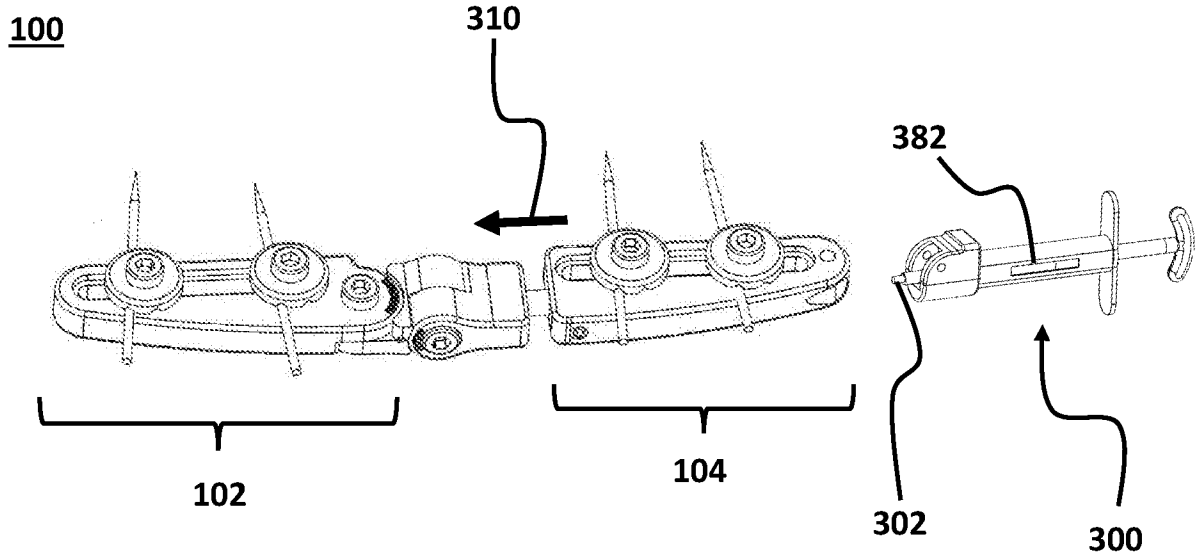

FIG. 3A

8/14

300

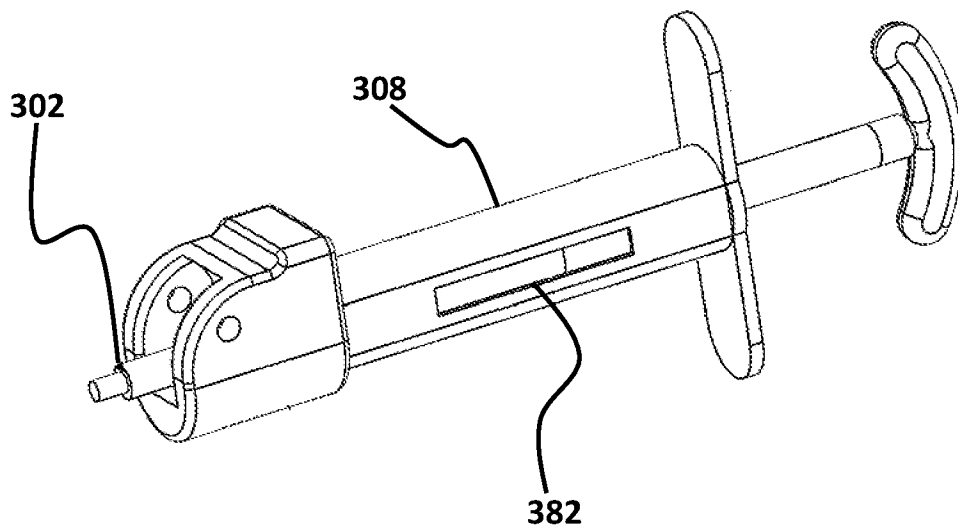

FIG. 3B

9/14

300

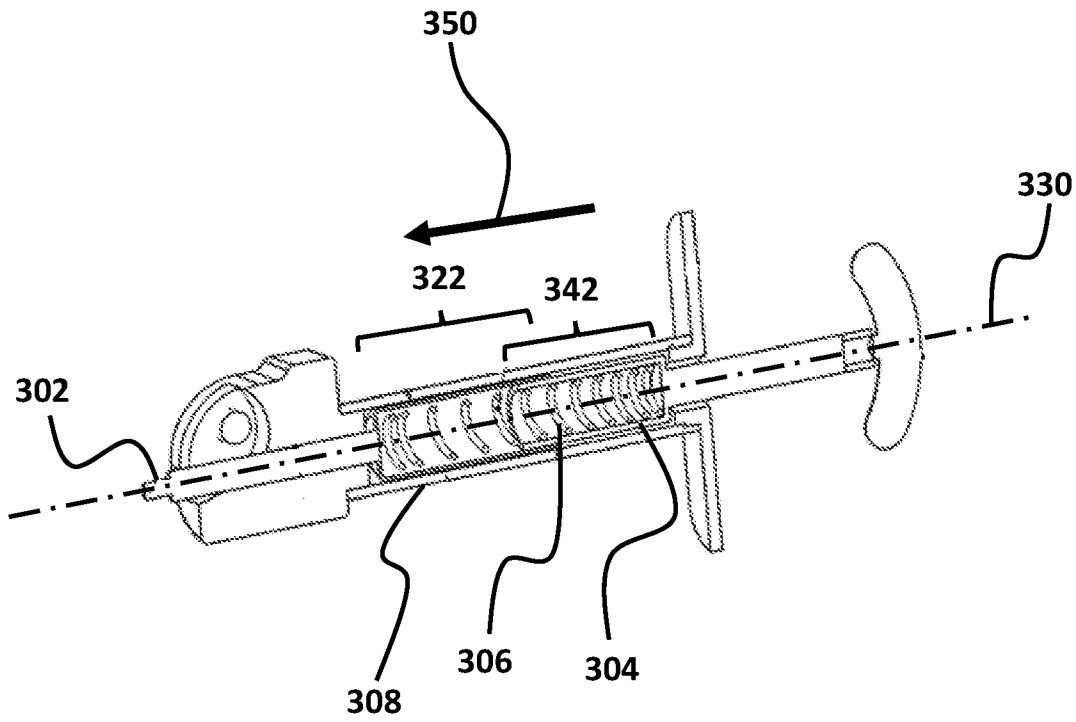

FIG. 3C

10/14

300

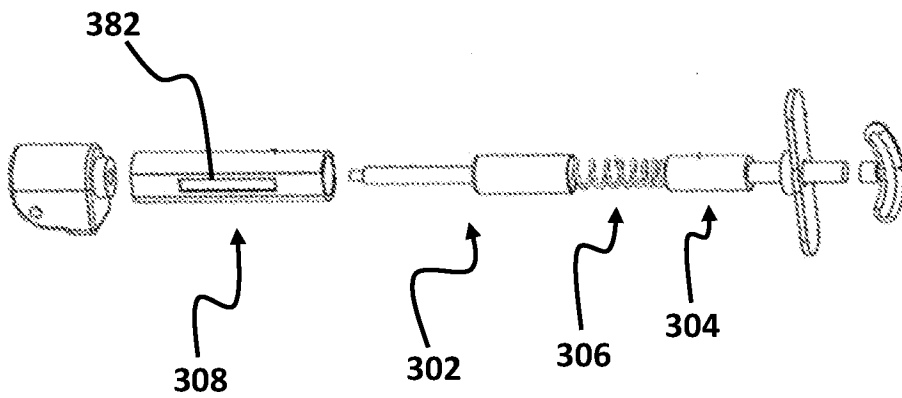

FIG. 3D

11/14

302

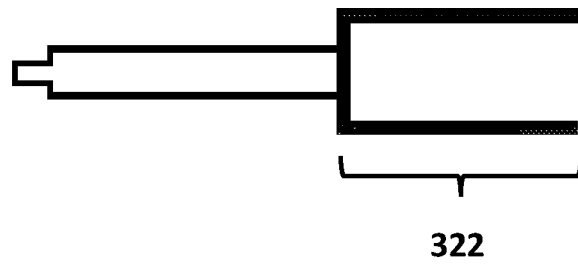

FIG. 3E

12/14

304

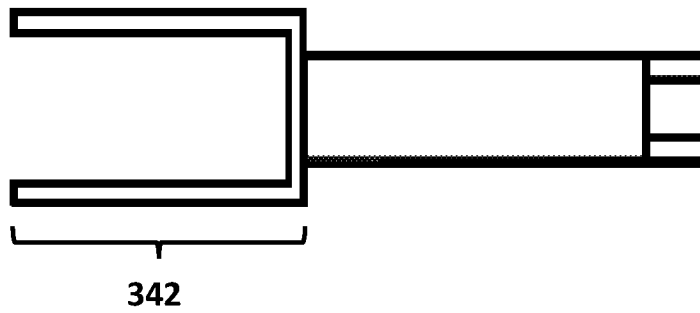

FIG. 3F

13/14

300

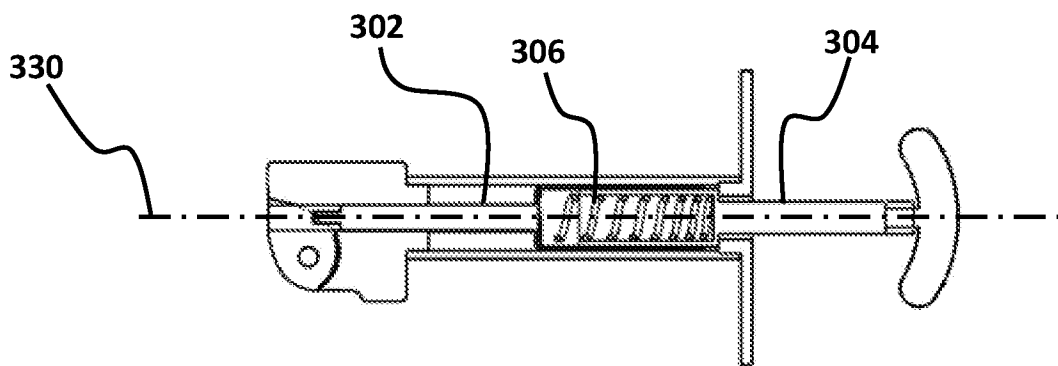

FIG. 3G

14/14

300

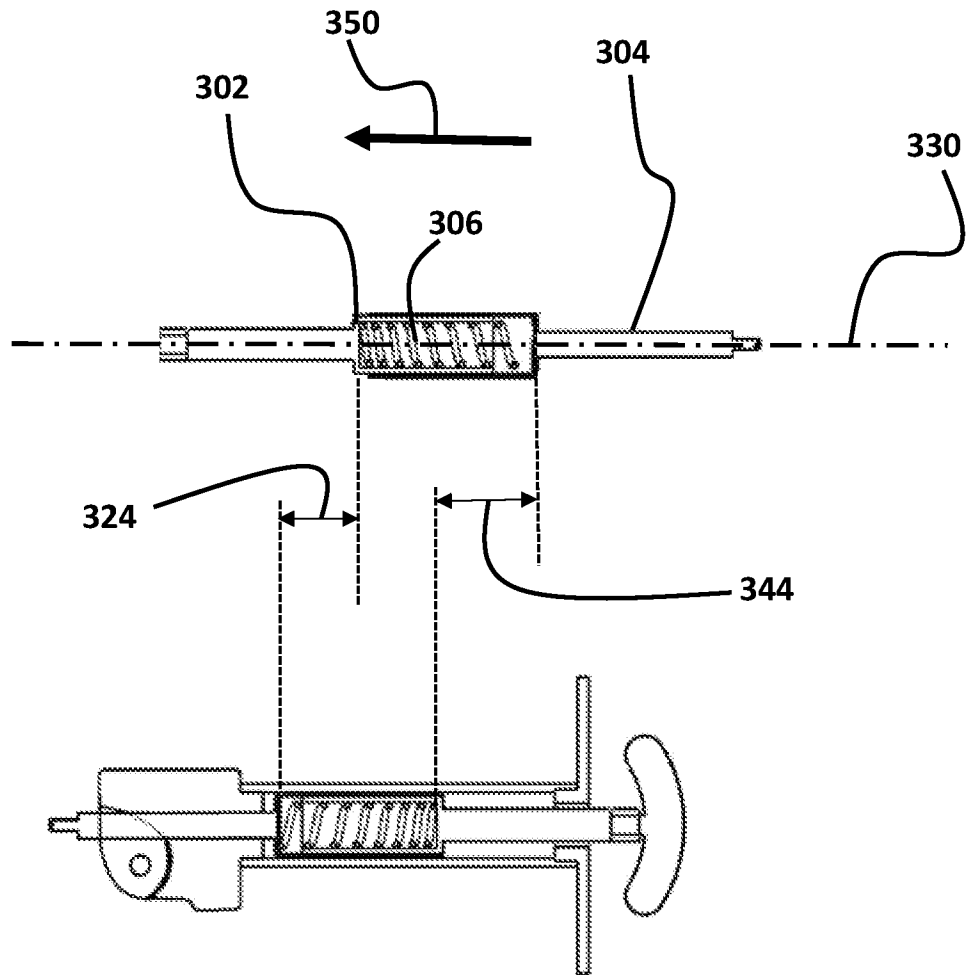

FIG. 3H

INTERNATIONAL SEARCH REPORT

International application No.
PCT/IB2019/059523

A. CLASSIFICATION OF SUBJECT MATTER
A61B17/00 Version=2020.01

According to International Patent Classification (IPC) or to both national classification and IPC

B. FIELDS SEARCHED

Minimum documentation searched (classification system followed by classification symbols)

A61B

Documentation searched other than minimum documentation to the extent that such documents are included in the fields searched

Electronic data base consulted during the international search (name of data base and, where practicable, search terms used)

Databases: TotalPatent One, IPO Internal Database

Keywords: External orthopedic fixation, radius member, metacarpus member

C. DOCUMENTS CONSIDERED TO BE RELEVANT

Category*	Citation of document, with indication, where appropriate, of the relevant passages	Relevant to claim No.
X	US 20040097944 A1 (AMEI TECHNOLOGIES INC (US)) 20 May 2004 (20.05.2004) Abstract, Description	1-12
X	EP 3179938 A1 (ZIMMER INC (US)) 21 June 2017 (21.06.2017) Abstract, Description	1-12

Further documents are listed in the continuation of Box C. See patent family annex.

* Special categories of cited documents:

"A" document defining the general state of the art which is not considered to be of particular relevance

"D" document cited by the applicant in the international application

"E" earlier application or patent but published on or after the international filing date

"L" document which may throw doubts on priority claim(s) or which is cited to establish the publication date of another citation or other special reason (as specified)

"O" document referring to an oral disclosure, use, exhibition or other means

"P" document published prior to the international filing date but later than the priority date claimed

"T" later document published after the international filing date or priority date and not in conflict with the application but cited to understand the principle or theory underlying the invention

"X" document of particular relevance; the claimed invention cannot be considered novel or cannot be considered to involve an inventive step when the document is taken alone

"Y" document of particular relevance; the claimed invention cannot be considered to involve an inventive step when the document is combined with one or more other such documents, such combination being obvious to a person skilled in the art

"&" document member of the same patent family

Date of the actual completion of the international search

03-02-2020

Date of mailing of the international search report

03-02-2020

Name and mailing address of the ISA/

Indian Patent Office
Plot No.32, Sector 14, Dwarka, New Delhi-110075
Facsimile No.

Authorized officer

Pritish Ranjan Pal

Telephone No. +91-1125300200

INTERNATIONAL SEARCH REPORT
Information on patent family members

International application No.
PCT/IB2019/059523

Citation	Pub.Date	Family	Pub.Date
US 20040097944 A1	20-05-2004	WO 2004010893 A2	05-02-2004
		EP 1545350 A4	13-08-2008
EP 3179938 A1	21-06-2017	WO 2016025375 A1	18-02-2016
		JP 2017523864 A	24-08-2017
		CN 106794034 B	16-08-2019