



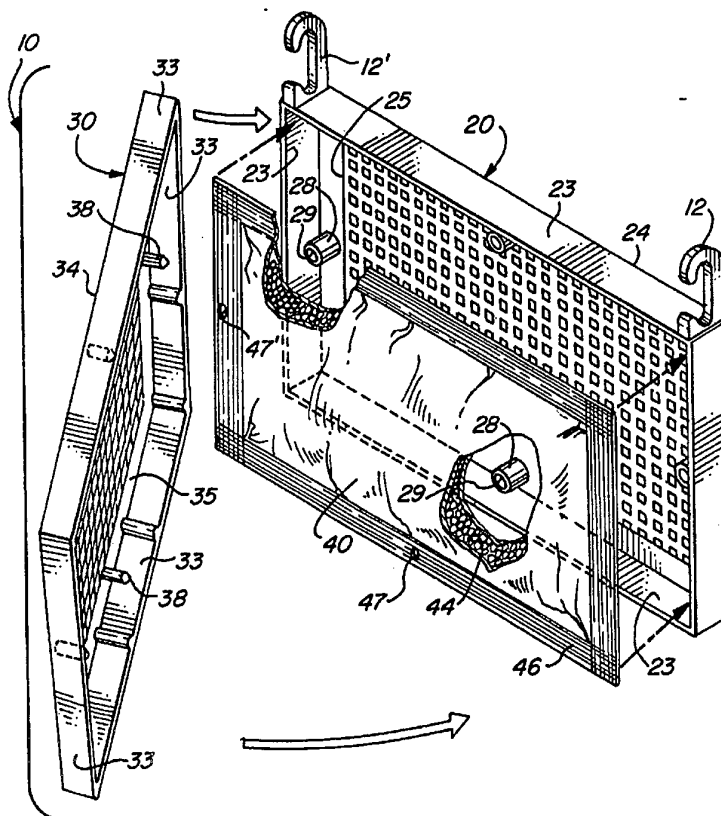
## INTERNATIONAL APPLICATION PUBLISHED UNDER THE PATENT COOPERATION TREATY (PCT)

<p>(51) International Patent Classification <sup>6</sup> : A61L 9/01, 9/12</p>	<p>A1</p>	<p>(11) International Publication Number: <b>WO 95/15187</b> (43) International Publication Date: 8 June 1995 (08.06.95)</p>
<p>(21) International Application Number: PCT/US94/13185 (22) International Filing Date: 15 November 1994 (15.11.94) (30) Priority Data: 08/159,732 30 November 1993 (30.11.93) US (71) Applicant: RECKITT &amp; COLMAN INC. [US/US]; 1655 Valley Road, Wayne, NJ 07474 (US). (72) Inventor: BERMAS, Edward, M.; 25 North Porchuck Road, Greenwich, CT 06831 (US). (74) Agents: RABIN, Frederick, H. et al.; Rosen, Dainow &amp; Jacobs, 489 Fifth Avenue, New York, NY 10017 (US).</p>	<p>(81) Designated States: AM, AT, AU, BB, BG, BR, BY, CA, CN, CZ, DE, DK, EE, ES, FI, GB, GE, HU, JP, KE, KG, KP, KR, KZ, LK, LR, LT, LU, LV, MD, MG, MN, MW, NL, NO, NZ, PL, PT, RO, RU, SD, SE, SI, SK, TJ, TT, UA, UZ, VN, European patent (AT, BE, CH, DE, DK, ES, FR, GB, GR, IE, IT, LU, MC, NL, PT, SE), OAPI patent (BF, BJ, CF, CG, CI, CM, GA, GN, ML, MR, NE, SN, TD, TG).</p> <p>Published With international search report.</p>	

(54) Title: REFRIGERATOR FRESHENER

(57) Abstract

A refrigerator freshening device includes an air-permeable container, enclosing a mixture, in particulate form, of a major amount of activated carbon and a minor amount of an odor-absorbing zeolite. The activated carbon is preferably characterized by a good distribution of large and small pores, at least 30 percent of the pores having a diameter of from about 15 to less than about 50 Å and the zeolite by a strong organophilic character and a surface area of at least about 400 square meters per gram. The combination of particulate adsorbent materials preferably includes from about 5 to about 25 percent of the zeolite and from about 75 to about 95 percent of the activated carbon. The device preferably includes a front panel, a back panel, and a package constructed of flexible, porous material enclosing adsorbent, wherein the front panel receives the back panel in nesting relationship and encloses the package of adsorbent material. Hooks are preferred to suspend the device freely within a refrigerator. The device maintains a fresh environment within a refrigerator, by acting immediately to delay the buildup of odors when aromatic foods are placed therein and continues to maintain low odor levels for extended times.



**FOR THE PURPOSES OF INFORMATION ONLY**

Codes used to identify States party to the PCT on the front pages of pamphlets publishing international applications under the PCT.

AT	Austria	GB	United Kingdom	MR	Mauritania
AU	Australia	GE	Georgia	MW	Malawi
BB	Barbados	GN	Guinea	NE	Niger
BE	Belgium	GR	Greece	NL	Netherlands
BF	Burkina Faso	HU	Hungary	NO	Norway
BG	Bulgaria	IE	Ireland	NZ	New Zealand
BJ	Benin	IT	Italy	PL	Poland
BR	Brazil	JP	Japan	PT	Portugal
BY	Belarus	KE	Kenya	RO	Romania
CA	Canada	KG	Kyrgystan	RU	Russian Federation
CF	Central African Republic	KP	Democratic People's Republic of Korea	SD	Sudan
CG	Congo	KR	Republic of Korea	SE	Sweden
CH	Switzerland	KZ	Kazakhstan	SI	Slovenia
CI	Côte d'Ivoire	LI	Liechtenstein	SK	Slovakia
CM	Cameroon	LK	Sri Lanka	SN	Senegal
CN	China	LU	Luxembourg	TD	Chad
CS	Czechoslovakia	LV	Latvia	TG	Togo
CZ	Czech Republic	MC	Monaco	TJ	Tajikistan
DE	Germany	MD	Republic of Moldova	TT	Trinidad and Tobago
DK	Denmark	MG	Madagascar	UA	Ukraine
ES	Spain	ML	Mali	US	United States of America
FI	Finland	MN	Mongolia	UZ	Uzbekistan
FR	France			VN	Viet Nam
GA	Gabon				

## DESCRIPTION

### REFRIGERATOR FRESHENER

#### Technical Field

5 The invention relates to an improved device for maintaining a fresh environment within a refrigerator, and especially to one which acts immediately to delay the buildup of odors when aromatic foods are placed therein and continues to maintain low odor levels for extended time periods.

10 The odors of various foods, such as onion, garlic, strong cheeses, gamey meats, and the like, often fill the refrigerator with a bouquet of strong and incompatible aromas. This presents the home cook with a problem -- beyond mere unpleasantness -- of the blending of odors and flavors among the various foods stored in the refrigerator. Long term storage is certainly a problem, but one particularly troublesome situation is the short term storage of foods prepared in  
15 advance of or brought to a dinner party or other social gathering. The desirable aroma of one dish can, by sharing its essence, diminish the character of another food.

20 Many techniques have been employed over the years to reduce the problem, and the most important of these is simply to use care when wrapping foods for refrigerator storage. However, even with care, some odors are just too strong to deal with and something more than discretion is required. Other

techniques have employed various odor eaters, such as baking soda, active carbon, certain zeolites, and the like. Each of these seems to provide some help, but there remains a need for a device and a technique that can moderate the level of odor initially as well as over time.

## 5 Background Art

The art of fresheners for refrigerators is unique to itself because of the wide variety of strong odors that are typically involved and the effect that they can have on the foods stored. This is clearly different from the art of air fresheners in general which often remove only certain types of odors or try to cover up some with others – perfumes and fragrances, no matter how pleasant, can't be employed. The additive effect of these materials with the naturally evolved odors from the contents of the refrigerator, will not necessarily be pleasant. Moreover, such additives can alter the desired flavor and aroma of stored materials. For refrigerators, odor controllers typically employ absorbent or adsorbent materials such as baking soda (NaHCO<sub>3</sub>), activated carbon, zeolites, clays and other minerals, and the like. Combinations of various of these materials have also been used for specified purposes, but no combination has been known to provide the desired short term and long term effects.

In U.S. Patent No. 3,990,872, Cullen describes an absorbent package made of spunbonded olefin walls holding a particulate adsorbent material. The adsorbent materials identified are silica gel, activated carbon, bentonite, montmorillonite, molecular sieve, and any other type of desiccant or adsorbent material desired. No direction is given for refrigerator use.

U.S. Patent No. 4,401,447, to Huber describes an adsorbent unit for use internally of a refrigerant system, but not a refrigerator *per se*. This patent also provides a wide variety of choices for adsorbents with no particular preference for

any. The adsorbent may selectively include, without limitation, adsorbents such as silica gel, metal, alumino silicate, alumina, calcium sulfate, activated charcoal, molecular sieve, or any other desired compound in bead, pellet or granular form.

In U.S. Patent No. 4,437,429, Goldstein *et al.* disclose, not a refrigerator  
5 freshener, but a litter for cats or other small animals. Their composition of a zeolite, such as clinoptilolite, in combination with a clay or other sorptive, non-colloidal granular aluminosilicate, is said to have extended life as compared to litters made of clay alone.

In U.S. Patent No. 4,534,775 and its divisional Patent No. 4,604,110, Frazier  
10 describes an air filter element -- of the type typically referred to as a room air freshener -- for use with a fan for drawing room air through it to remove odors. The filter element includes a dry mixture of silica gel, activated carbon, and a zeolite, all preferably in particulate form, packed into a filter body so as to minimize the pore volume or void space. The dry mixture can be impregnated with a liquid for  
15 inhibiting the growth of microorganisms. While each of the components of the dry mixture is disclosed to be used at a level of from about 10 to 80 weight percent, it is preferred to employ essentially equal weights of each. The patentee discloses that the materials together synergistically remove a wide spectrum of household odors.

20 In U.S. Patent No. 4,795,482, Gioffre *et al.* describe reducing odors attributable to organic molecular species, through the use of a crystalline molecular sieve material having at least 90% of its tetrahedral oxide units as SiO<sub>2</sub> tetrahedra, having pore apertures nominally at least 5.5Å in diameter, and meeting other  
25 criteria. This class of materials is said to include zeolites as well as the so-called silica polymorphs. Comparisons are cited between these molecular sieves (exemplified as zeolites), activated charcoal, silicalite, silica gel, NaHCO<sub>3</sub>, and mixtures of the zeolite with silicalite. Combinations of charcoal and zeolite were not tested.

In U.S. Patent No. 4,826,497, Marcus *et al.* disclose a fibrous absorbent article (disposable diapers, catamenial devices, wound dressings, etc.) containing a suitable zeolite having the ability to deodorize with respect to bodily fluids, even in the presence of water. Comparisons are made between several zeolites, activated charcoal, silica gel, silicalite,  $\text{NaHCO}_3$ , and various combinations other than the combination of activated charcoal and zeolite.

Thus, despite the wide range of prior art describing and comparing various gas adsorbing materials for use in various deodorizing situations, it has not been previously recognized that combinations of crystalline aluminosilicate zeolite adsorbents, in minor amount, with a major amount of activated charcoal, would have particular utility for a refrigerator freshener -- particularly one which fills the need for rapid response in combination with long acting odor reduction.

#### **Brief Description of the Drawings**

The invention will be better understood and its advantages will be better appreciated from the following detailed description, especially when read in connection with the accompanying drawings, wherein:

Figure 1 is a perspective view of a preferred form of air freshener of the invention freely hanging within a refrigerator compartment;

Figure 2 is an exploded perspective view, partially cut away, showing a preferred form of refrigerator freshener of the invention;

Figure 3 is a front elevational view of the refrigerator freshener shown in Figure 2;

Figure 4 is a cross-sectional view of a preferred form of refrigerator freshener of the invention, taken along line 4-4 in Figure 3; and

Figure 5 is an enlarged view of detail of the refrigerator freshener shown in Figure 3.

### Disclosure of the Invention

It is an object of the invention to provide an improved device for maintaining the freshness of the air within a refrigerator.

It is another object of the invention to provide an improved device for main-  
5 taining the freshness of the air within a refrigerator by immediately eliminating odors to prevent their buildup after placing odorous foods in the refrigerator.

It is a more specific object of the invention to provide an improved device for  
maintaining the freshness of the air within a refrigerator, especially shortly after  
placing therein highly odorous foods, such as onion, garlic, strong cheeses, aged  
10 meats, and the like.

It is yet another object of the invention to provide a device and a technique  
for its use which can moderate the level of odor in a refrigerator both when storing  
foods both initially and over extended times.

15 These and other objects are realized by the present invention which provides both a device and a technique for its use which can moderate the level of odor initially as well as over time. The device, in one of its broader aspects comprises an air-permeable container enclosing a mixture, in particulate form, of a major amount of active carbon and a minor amount of an odor-absorbing zeolite.

20 The technique or process of the invention comprises suspending the container, as described above, from a refrigerator shelf to permit the normal movement of air within the refrigerator to pass by and be deodorized by the active carbon and the zeolite.

The combination of particulate adsorbent materials preferably includes from  
25 about 5 to about 25 percent of the zeolite and from about 75 to about 95 percent of the activated carbon. Unless otherwise indicated, all parts and percentages used

in the specification, are based on the weight of the ingredient or material at the indicated stage of processing.

The device preferably includes a front panel, a back panel, and a package constructed of flexible, porous material enclosing adsorbent, wherein the front panel receives the back panel in nesting relationship and encloses the package of adsorbent material. Hooks are preferred to suspend the device freely within a refrigerator.

### Industrial Applicability

The invention will be described below with specific reference to a preferred embodiment as illustrated in Figures 1 through 5. The refrigerator freshening device 10 of the invention preferably includes hooks 12 and 12' to facilitate hanging it from a wire shelf element 14 in a refrigerator 16 as shown in Figure 1.

The ability to freely suspend the device 10 in this manner permits a free circulation of air around and into contact with it by maintaining it in a position off of the storage surfaces. The device 10 permits bulk flow of air within the refrigerator 16 to come into contact with it at a sufficient rate and for a sufficient time period to immediately have a significant odor reducing effect on odors emanating from foods. Accordingly, when a variety of foods are prepared ahead of time for an event and placed in the refrigerator, the refrigerator freshening device of the invention will help each food maintain its own natural flavor and aroma, unadulterated by the odors of the other foods.

Figure 2 is an exploded view showing the principal structural features of the refrigerator freshener of the invention. A front panel 20 receives back panel 30 in nesting relationship, enclosing adsorbent package 40.



-7-

The front panel 20 includes a rectangular front wall member 22 (see Figure 4), and four side wall members 23. The front wall member has an outside surface 24 (see Figures 3 and 4) and an inside surface 25. The detail of Figure 5 shows the grid structure provided by ribs 26 and holes 27 which extend through the front wall member from the inside surface to the outside surface. Extending outwardly from the inside surface, and positioned near each of the side wall members 23, are posts 28 having holes 29 therein. As will be explained below, the posts function with the package 40 and complimentary means on the back panel to suspend the package.

The back panel 30 includes a rectangular rear wall member 32, and four side wall members 33. The rear wall member has an outside surface 34 (see Figure 4) and an inside surface 35 with a grid structure 36 which is similar in structure to that of the front panel. Posts 38 extend outwardly from the inside surface 35 of back panel 30. The posts 38 are located at suitable positions to enable engagement with the holes 29 in posts 28 on the front wall member. The posts 38 should be of similar diameter as the holes, optionally with a slight taper or other means facilitating mechanical or frictional interlock, to permit a secure fit. The outer dimension of the rear panel 30 is defined by wall members 33 and is selected to nest within the opening defined by the wall members 23 of the front panel 20. It will be apparent, however, that the post and wall panel dimensions can be varied as desired to achieve the necessary structural integrity of the unit with the package 40 suspended between the porous front and rear panel members.

The package 40 includes a porous outer wall member 42 which encloses a granular adsorbent 44 composition which comprises a major amount of activated carbon and a minor amount of zeolite. Preferably, the porous outer wall member should have a porosity at least sufficient to permit refrigerator air to freely flow into and out of the package but not so great as to permit dust from the particulate adsorbents to escape through the pores. Preferably, the permeability will be within the range of up to about 100 gurley seconds, e.g. from about 5 to about 25 gurley seconds.

-8-

In practice, porous paper and nonwoven polymeric felt materials such as employed for teabags, coffee filters, and as specifically available for use in making pouches for odor adsorbents, can be employed. A preferred material is made of a nonwoven fabric comprised of polyester and polypropylene, e.g. at a ratio of 63.3  
5 parts polyester to 36.7 parts of the polypropylene. The package shown in the drawing is made by cutting two thicknesses of a heat-sealable nonwoven fabric, which is sealed around the entire periphery to enclose particulate adsorbent 44 and provide a compressed marginal edge 46. Holes as needed, e.g. 47 and 47', can be provided to suspend the package from posts 28 between the front and rear panels.

10 The surprisingly good combination of effectiveness for initial response to strong odors and extended effectiveness against accumulating odors achieved by the refrigerator freshener of the invention is believed due to the combination of the activated carbon and the zeolite. The loose packing of the particulate materials in the package 40, its suspension between the porous front and rear wall members 22  
15 and 32, and the suspension of the device by hooks 12 and 12' in the freely circulating air in a refrigerator enhance this effectiveness. Preferably, the particulate materials will have a bulk density of from about 0.3 to about 0.6 grams per cubic centimeter.

Preferred forms of activated carbon are characterized by a good distribution  
20 of large and small pores, preferably with at least 30 percent of the pores having a diameter of from about 15 to less than about 50 Å, most preferably from about 15 to about 20 Å, and one preferred form is available from Calgon as BPL 6x16 granular carbon.

Preferred forms of zeolite are characterized by a strong organophilic  
25 character and a surface area of at least about 400 square meters per gram, and one preferred form is available from UOP as Abscents® deodorizing powders. In general, the preferred zeolites are those crystalline molecular sieve materials having at least 90% of their tetrahedral oxide units as SiO<sub>2</sub> tetrahedra, and having

pore apertures nominally at least 5.5Å in diameter, such as described in the above-mentioned U.S. Patent No. 4,795,482, which is hereby incorporated in its entirety.

Preferred combinations of these granular adsorbent materials will consist essentially of a zeolite and activated carbon, including from about 5 to about 25  
5 percent of the zeolite and from about 75 to about 95 percent of the activated carbon. The most preferred combinations will contain from about 7 to about 15 percent of the zeolite, e.g. about 9 percent, with from about 85 to about 93 percent of the activated carbon.

The above description is intended to enable the person skilled in the art to  
10 practice the invention. It is not intended to detail all of the possible modifications and variations which will become apparent to the skilled worker upon reading the description. It is intended, however, that all such modifications and variations be included within the scope of the invention which is defined by the following claims. The claims are meant to cover the indicated elements and steps in any arrangement  
15 or sequence which is effective to meet the objectives intended for the invention, unless the context specifically indicates the contrary.

**CLAIMS**

1. A refrigerator freshening device comprising:  
an air-permeable container; and  
enclosed within said container, a mixture in particulate form, of a major  
5 amount of activated carbon and a minor amount of an odor-absorbing zeolite.
2. A refrigerator freshening device according to claim 1, wherein the activated  
carbon is characterized by a good distribution of large and small pores, at least 30  
percent of the pores having a diameter of from about 15 to less than about 50 Å.
3. A refrigerator freshening device according to claim 1, wherein the zeolite is  
10 characterized by a strong organophilic character and a surface area of at least  
about 400 square meters per gram.
4. A refrigerator freshening device according to claim 1, wherein the combination  
of particulate adsorbent materials consists essentially of a zeolite and activated  
carbon, including from about 5 to about 25 percent of the zeolite and from about 75  
15 to about 95 percent of the activated carbon.
5. A refrigerator freshening device according to claim 4, wherein the combination  
of particulate adsorbent materials consists essentially of a zeolite and activated  
carbon, including 7 to about 15 percent of the zeolite.
6. A refrigerator freshening device according to claim 1, which further comprises:  
20 a front pane;  
a back panel; and

a package constructed of flexible, porous material enclosing the absorbent; wherein the front panel receives the back panel in nesting relationship and encloses the package of adsorbent material.

7. A refrigerator freshening device according to claim 1, wherein:

5 the front panel includes a rectangular front wall member and four side wall members;

the front wall member has an outside surface, an inside surface, and a grid structure including holes which extend through the front wall member from the inside surface to the outside surface.

10 8. A refrigerator freshening device according to claim 1, wherein: the rear panel includes a rectangular rear wall member and four side wall members;

the rear wall member has an outside surface, an inside surface, and a grid structure including holes which extend through the rear wall member from the inside surface to the outside surface.

15 9. A refrigerator freshening device according to claim 8, which further includes:

front panel posts extending outwardly from the inside surface of the front panel, and positioned near each of the side wall members, the posts having holes therein;

20 posts extending outwardly from the inside surface of said rear panel complementary with said front panel posts to secure the front panel to the rear panel and suspend the package.

10. A refrigerator freshening device according to claim 8, which further includes:

at least one hook to enable suspension of the device from a refrigerator shelf.

25 11. A refrigerator freshening device comprising:

an air-permeable container; and

enclosed within said container, a mixture in particulate form, consisting essentially of a major amount of active carbon characterized by a good distribution of large and small pores, at least 30 percent of the pores having a diameter of from about 15 to less than about 50 Å and a minor amount of an odor-absorbing zeolite  
5 characterized by a strong organophilic character and a surface area of at least about 400 square meters per gram.

12. A refrigerator freshening device according to claim 11, including from about 5 to about 25 percent of the zeolite and from about 75 to about 95 percent of the activated carbon.

10 13. A refrigerator freshening device according to claim 12, wherein the combination of particulate adsorbent materials includes from about 7 to about 15 percent of the zeolite.

14. A refrigerator freshening device according to claim 12, which further comprises:

15 a front panel including a rectangular front wall member and four side wall members, the front wall member having an outside surface, an inside surface, and a grid structure including holes which extend through the front wall member from the inside surface to the outside surface;

20 a back panel, including a rectangular rear wall member and four side wall members, the rear wall member having an outside surface, an inside surface, and a grid structure including holes which extend through the rear wall member from the inside surface to the outside surface;

a package constructed of flexible, porous material enclosing the adsorbent;  
wherein the front panel receives the back panel in nesting relationship and  
25 encloses the package of adsorbent material; and

at least one hook to enable suspension of the device from a refrigerator shelf.

15. A process for maintaining a fresh environment within a refrigerator, by acting immediately to delay the buildup of odors when aromatic foods are placed therein and continuing to maintain low odor levels for extended times, comprising:

5 providing an air-permeable container having enclosed therein, a mixture in particulate form, of a major amount of active carbon and a minor amount of an odor-absorbing zeolite; and

suspending the container from a refrigerator shelf to permit the normal movement of air within the refrigerator to pass by and be deodorized by the active carbon and the zeolite.

10 16. A process according to claim 15, wherein the activated carbon is characterized by a good distribution of large and small pores, at least 30 percent of the pores having a diameter of from about 15 to less than about 50 Å.

15 17. A process according to claim 15, wherein the zeolite is characterized by a strong organophilic character and a surface area of at least about 400 square meters per gram.

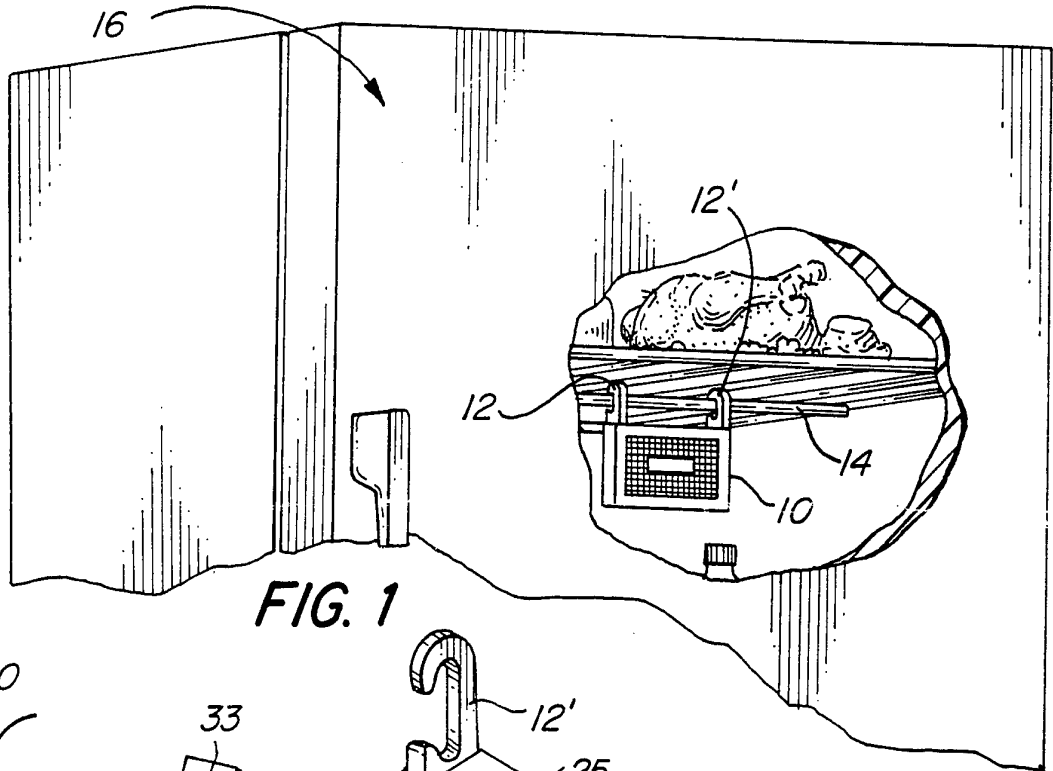
18. A process according to claim 15, wherein the combination of particulate adsorbent materials consists essentially of a zeolite and activated carbon, including from about 5 to about 25 percent of the zeolite and from about 75 to about 95 percent of the activated carbon.

20 19. A process according to claim 18, wherein the combination of particulate adsorbent materials consists essentially of a zeolite and activated carbon, including 7 to about 15 percent of the zeolite.

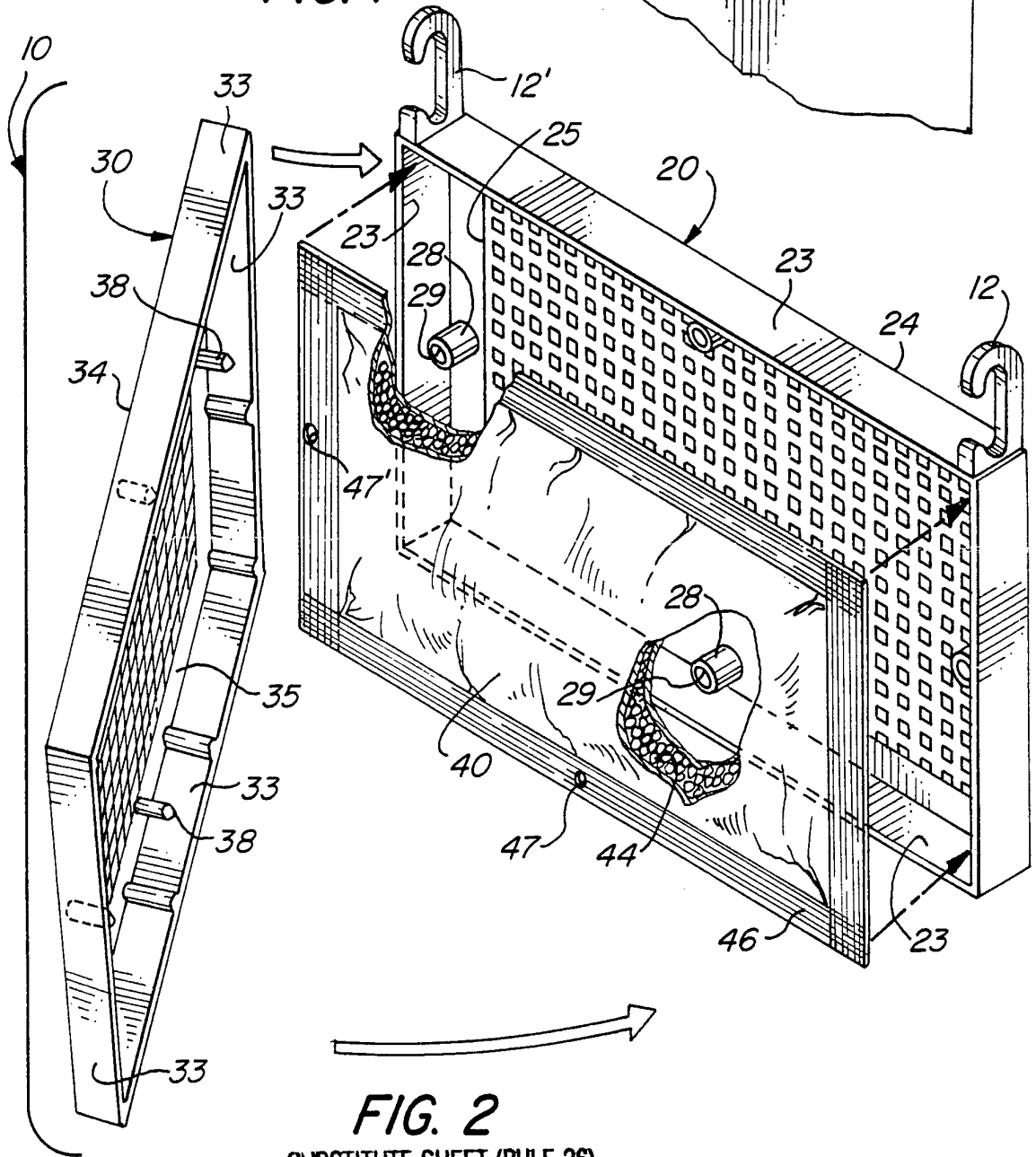
25 20. A process according to claim 18, wherein the activated carbon is characterized by a good distribution of large and small pores, at least 30 percent of the pores having a diameter of from about 15 to less than about 50 Å and the zeolite is

characterized by a strong organophilic character and a surface area of at least about 400 square meters per gram.



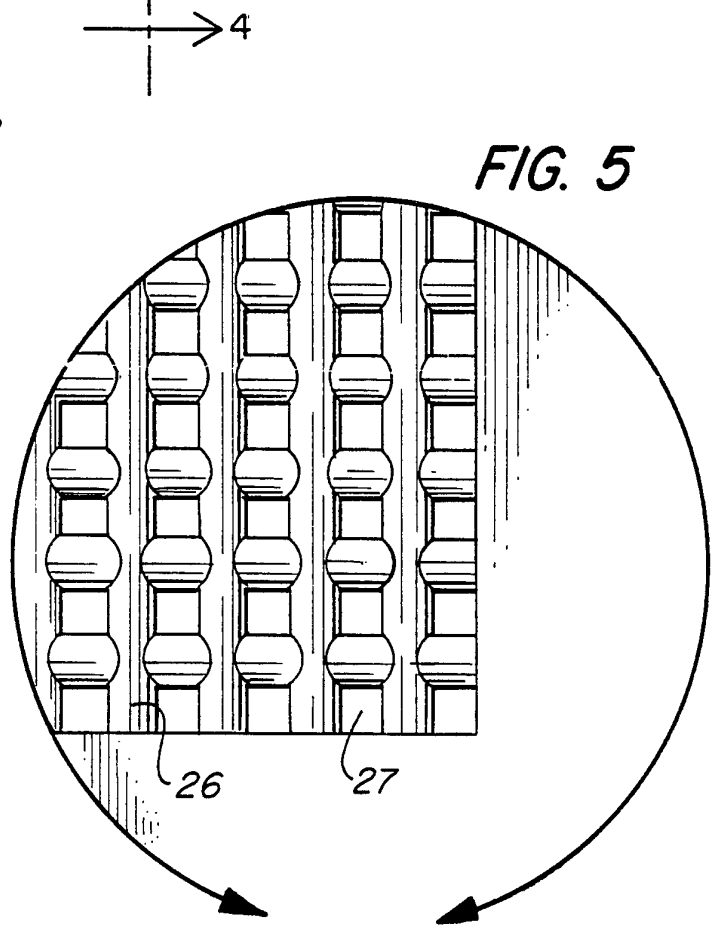
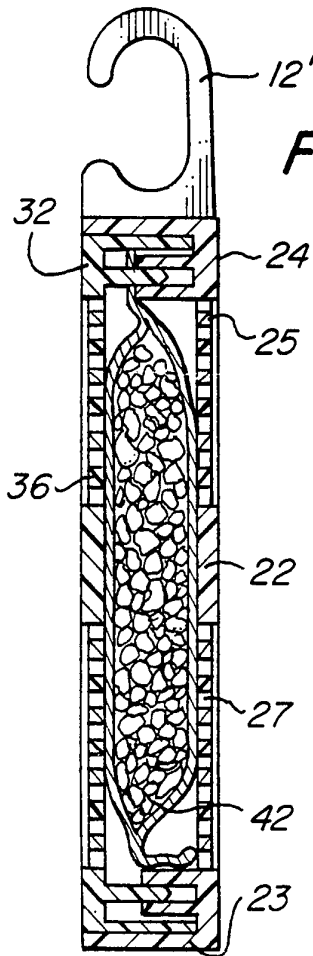
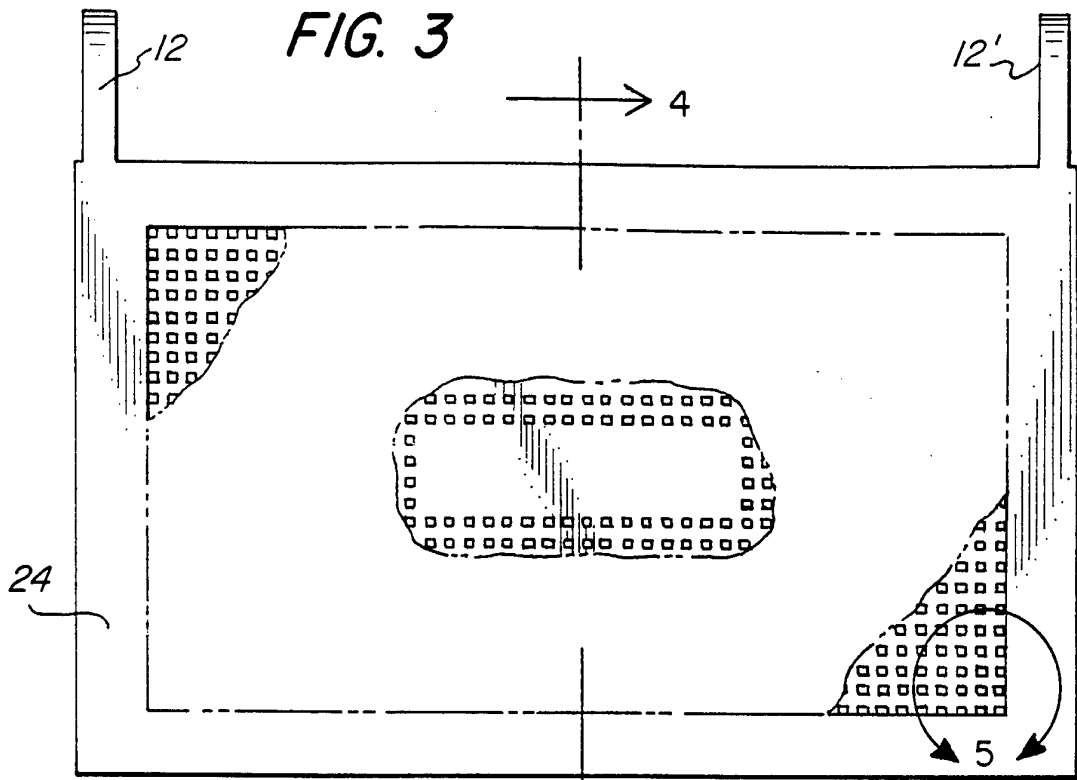


**FIG. 1**



**FIG. 2**

SUBSTITUTE SHEET (RULE 26)



## INTERNATIONAL SEARCH REPORT

International Application No

PCT/US 94/13185

A. CLASSIFICATION OF SUBJECT MATTER  
 IPC 6 A61L9/01 A61L9/12

According to International Patent Classification (IPC) or to both national classification and IPC

## B. FIELDS SEARCHED

Minimum documentation searched (classification system followed by classification symbols)

IPC 6 A61L

Documentation searched other than minimum documentation to the extent that such documents are included in the fields searched

Electronic data base consulted during the international search (name of data base and, where practical, search terms used)

## C. DOCUMENTS CONSIDERED TO BE RELEVANT

Category *	Citation of document, with indication, where appropriate, of the relevant passages	Relevant to claim No.
Y	WO,A,86 05120 (GENERAL TIME CORPORATION) 12 September 1986 see page 7, line 7 - line 22 see page 8, line 8 - line 10 see page 9, line 1 - line 13 see page 13, line 35 - line 36 see page 14, line 1 - line 2 ---	1-20
Y	US,A,5 062 272 (MARSHA L. BURNS.) 5 November 1991 see the whole document --- -/--	1-20

Further documents are listed in the continuation of box C.

Patent family members are listed in annex.

\* Special categories of cited documents :

"A" document defining the general state of the art which is not considered to be of particular relevance

"E" earlier document but published on or after the international filing date

"L" document which may throw doubts on priority claim(s) or which is cited to establish the publication date of another citation or other special reason (as specified)

"O" document referring to an oral disclosure, use, exhibition or other means

"P" document published prior to the international filing date but later than the priority date claimed

"T" later document published after the international filing date or priority date and not in conflict with the application but cited to understand the principle or theory underlying the invention

"X" document of particular relevance; the claimed invention cannot be considered novel or cannot be considered to involve an inventive step when the document is taken alone

"Y" document of particular relevance; the claimed invention cannot be considered to involve an inventive step when the document is combined with one or more other such documents, such combination being obvious to a person skilled in the art.

"&" document member of the same patent family

Date of the actual completion of the international search

28 February 1995

Date of mailing of the international search report

16.03.95

Name and mailing address of the ISA

European Patent Office, P.B. 5818 Patentlaan 2  
 NL - 2280 HV Rijswijk  
 Tel. (+ 31-70) 340-2040, Tx. 31 651 epo nl,  
 Fax: (+ 31-70) 340-3016

Authorized officer

ESPINOSA, M

## INTERNATIONAL SEARCH REPORT

International Application No

PCT/US 94/13185

C.(Continuation) DOCUMENTS CONSIDERED TO BE RELEVANT		
Category *	Citation of document, with indication, where appropriate, of the relevant passages	Relevant to claim No.
A	DATABASE WPI Week 8220, Derwent Publications Ltd., London, GB; AN 82-40295 & JP,A,57 059 634 (ENKLAR BUSINESS KK) 10 April 1982 see abstract ---	1
A	DATABASE WPI Week 8915, Derwent Publications Ltd., London, GB; AN 89-111437 & JP,A,1 058 343 (NIPPON KANKO SHIKI) 6 March 1989 see abstract ---	1
A	DATABASE WPI Week 9031, Derwent Publications Ltd., London, GB; AN 90-235969 & JP,A,2 164 414 (DAIE SHOKUHIN KOGYO) 25 June 1990 see abstract ---	1
A	GB,A,2 259 858 (GLANMOR THOMAS WILLIAMS.) 31 March 1993 see claims -----	1

INTERNATIONAL SEARCH REPORT

Information on patent family members

International Application No

PCT/US 94/13185

Patent document cited in search report	Publication date	Patent family member(s)	Publication date
WO-A-8605120	12-09-86	US-A- 4604110 CA-A- 1259295 JP-T- 62502519	05-08-86 12-09-89 01-10-87
----- US-A-5062272	05-11-91	NONE	-----
----- GB-A-2259858	31-03-93	NONE	-----