

[54] ELECTRONIC BAR CODE READER

[75] Inventors: Vernon L. Stant, Richmond, Va.;
Michael S. Beard, Pineville, N.C.;
James M. DeArras, Richmond, Va.;
Allen M. Grayson; Frederick M.
Weaver, both of Charlotte, N.C.

[73] Assignee: Hand Held Products, Charlotte, N.C.

[**] Term: 14 Years

[21] Appl. No.: 879,793

[22] Filed: Jun. 27, 1986

Related U.S. Application Data

[63] Continuation of Ser. No. 817,910, Jan. 10, 1986, abandoned.

[52] U.S. Cl. D14/116

[58] Field of Search D14/105, 107, 114, 115,
D14/116; 235/454, 470, 472; 250/203 R, 566

References Cited

U.S. PATENT DOCUMENTS

D. 248,946	8/1978	Koenig	D14/116
D. 267,950	2/1983	Ault	D14/115
4,420,682	12/1983	Huber	235/472
4,423,319	12/1983	Jacobsen	235/472
4,445,028	4/1984	Huber	235/472
4,471,218	9/1984	Culp	235/472

Primary Examiner—Susan J. Lucas

Attorney, Agent, or Firm—Bell, Seltzer, Park & Gibson

[57] CLAIM

The ornamental design for an electronic bar code reader, substantially as shown and described.

DESCRIPTION

FIG. 1 is a front perspective view of an electronic bar code reader showing the new design;

FIG. 2 is a rear perspective view of the design rotated 180°;

FIG. 3 is a top plan view of the design;

FIG. 4 is a front elevational view of the design;

FIG. 5 is a bottom plan view of the design;

FIG. 6 is a rear elevational view of the design;

FIG. 7 is an end elevational view looking at the left end in the direction of arrow 7 of FIG. 4;

FIG. 8 is an end elevational view looking at the right end in the direction of arrow 8 of FIG. 4;

FIG. 9 is a front perspective view of a second embodiment of the new design;

FIG. 10 is a front elevational view of this second embodiment;

FIG. 11 is a front perspective view of a third embodiment of the new design;

FIG. 12 is a rear perspective view of this third embodiment rotated 180°;

FIG. 13 is a top plan view of this third embodiment;

FIG. 14 is a front elevational view of this third embodiment;

FIG. 15 is a bottom plan view of this third embodiment;

FIG. 16 is a rear elevational view of this third embodiment;

FIG. 17 is an end elevational view of this third embodiment looking at the left end in the direction of arrow 17 of FIG. 14;

FIG. 18 is an end elevational view of this third embodiment looking at the right end in the direction of arrow 18 of FIG. 14;

FIG. 19 is a front perspective view of a fourth embodiment of the new design; and

FIG. 20 is a front elevational view of this fourth embodiment.

The first embodiment (FIGS. 1-8) and second embodiment (FIGS. 9-10) are identical in the configuration of the housing, differing in the arrangement of the keys on the front control panel. The third embodiment (FIGS. 11-18) and fourth embodiment (FIGS. 19-20) are identical in the configuration of the housing, differing in the arrangement of the keys on the front control panel.

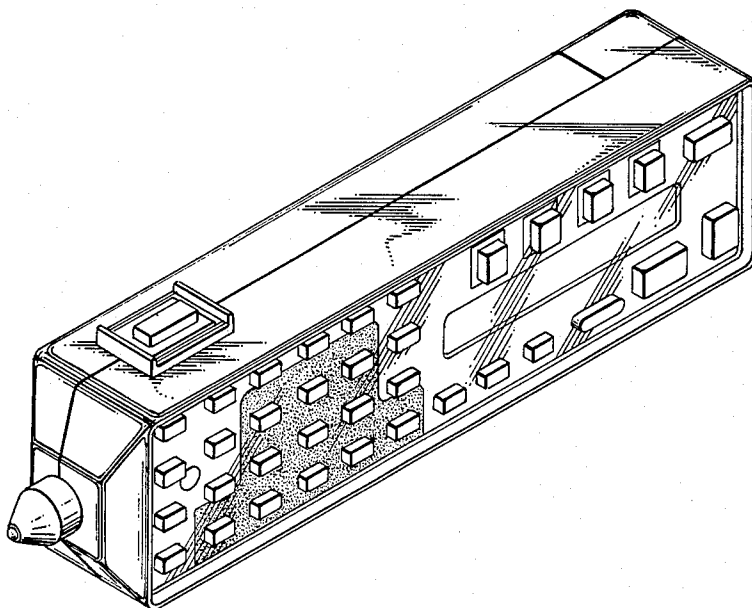

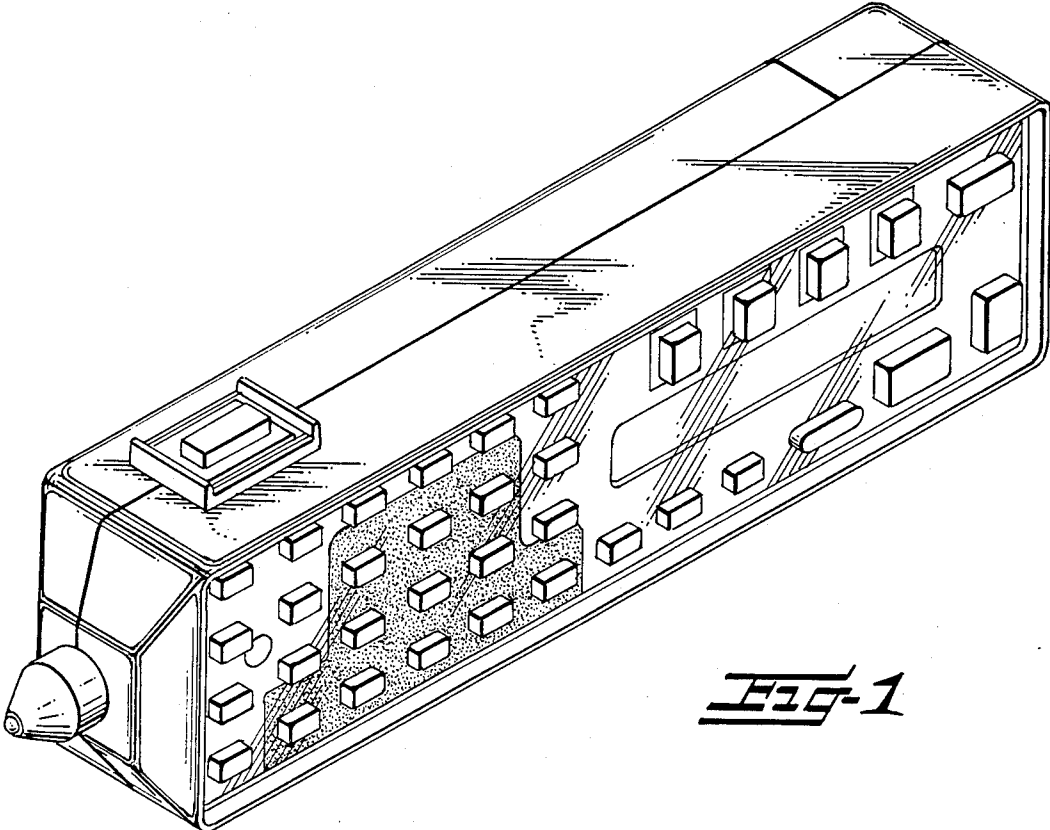

FIG-1

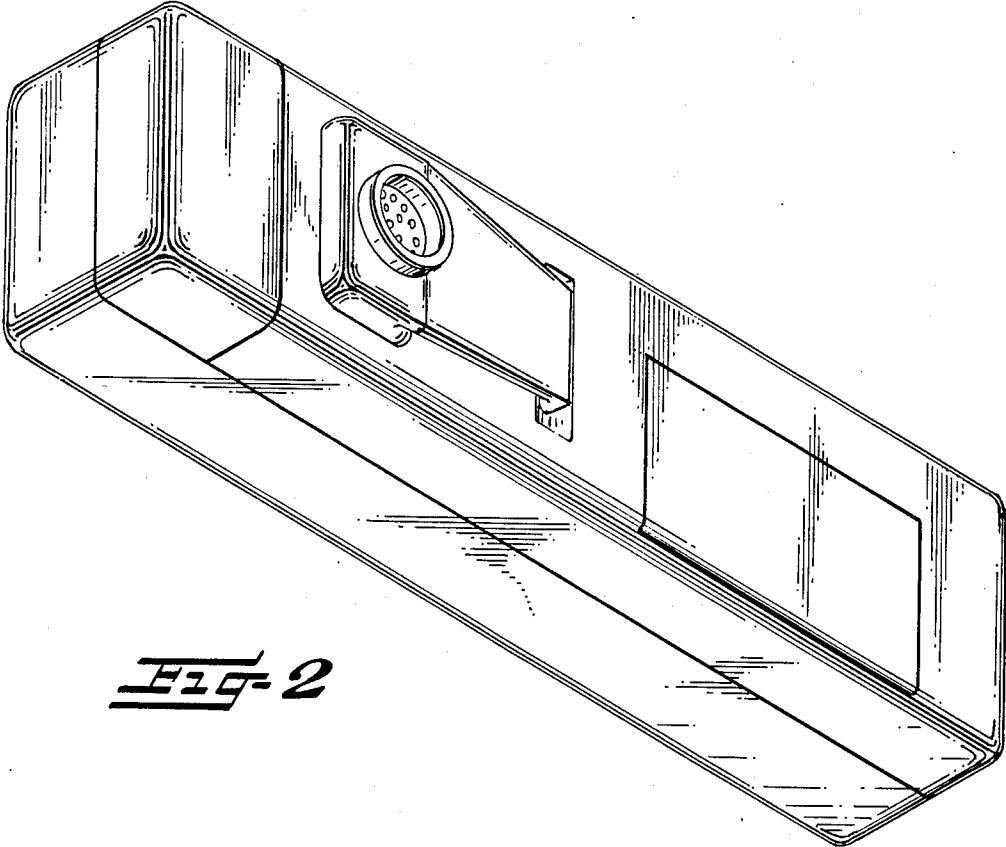

FIG-2

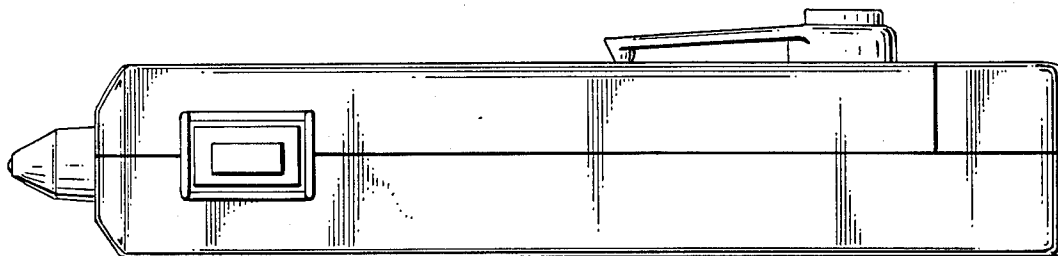

Fig-3

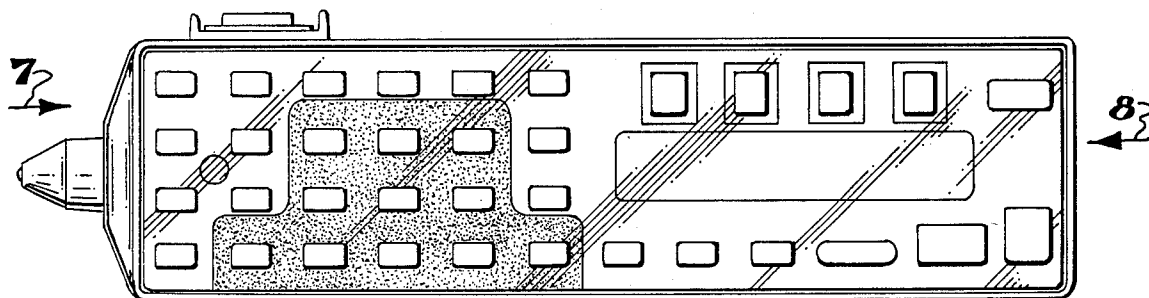

Fig-4

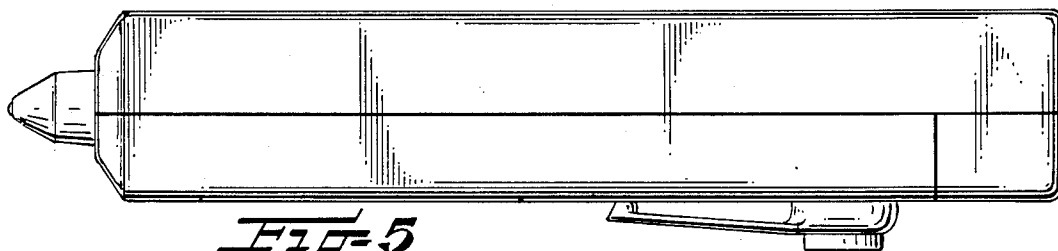

Fig-5

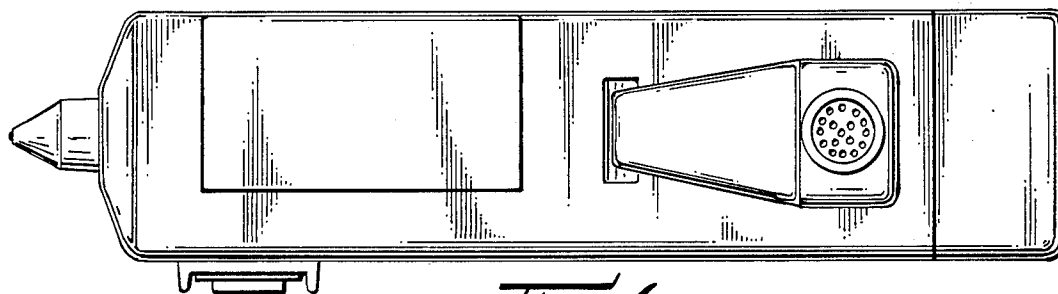

Fig-6

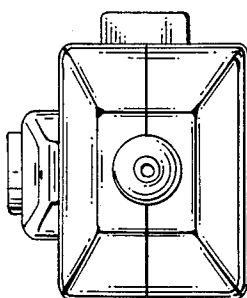

Fig-7

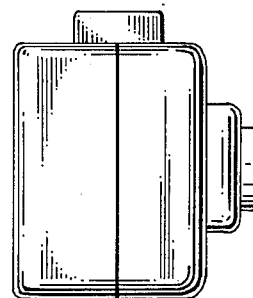

Fig-8

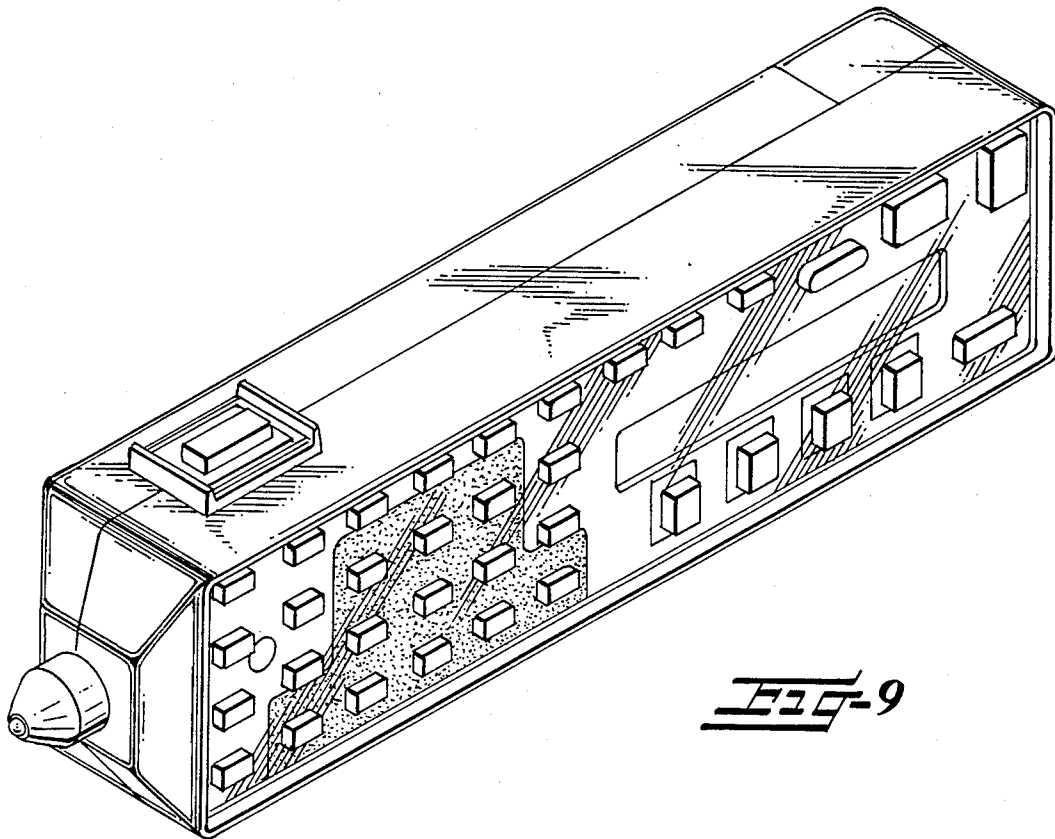

FIG-9

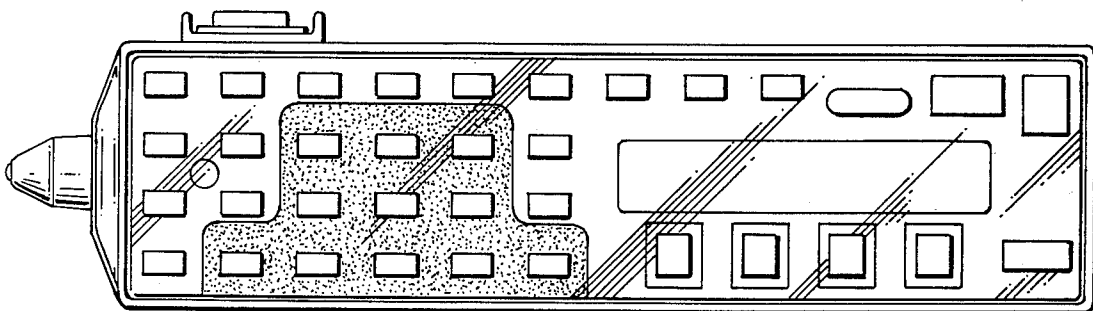

FIG-10

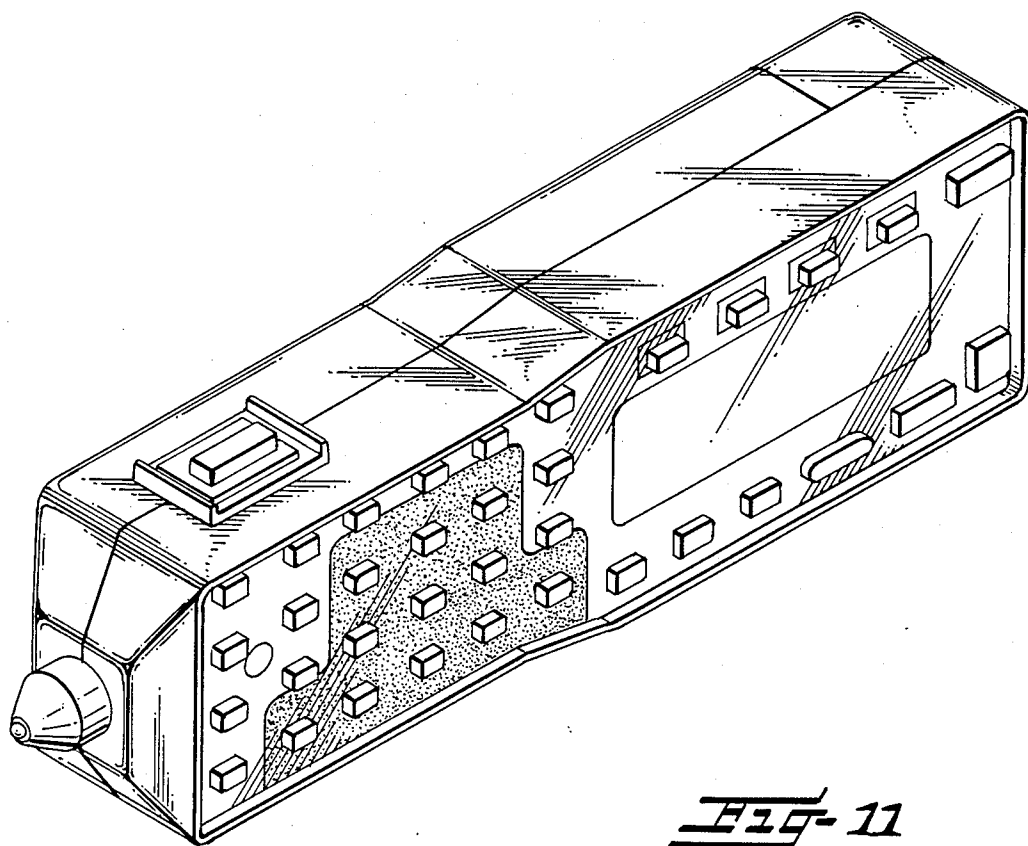

FIG-11

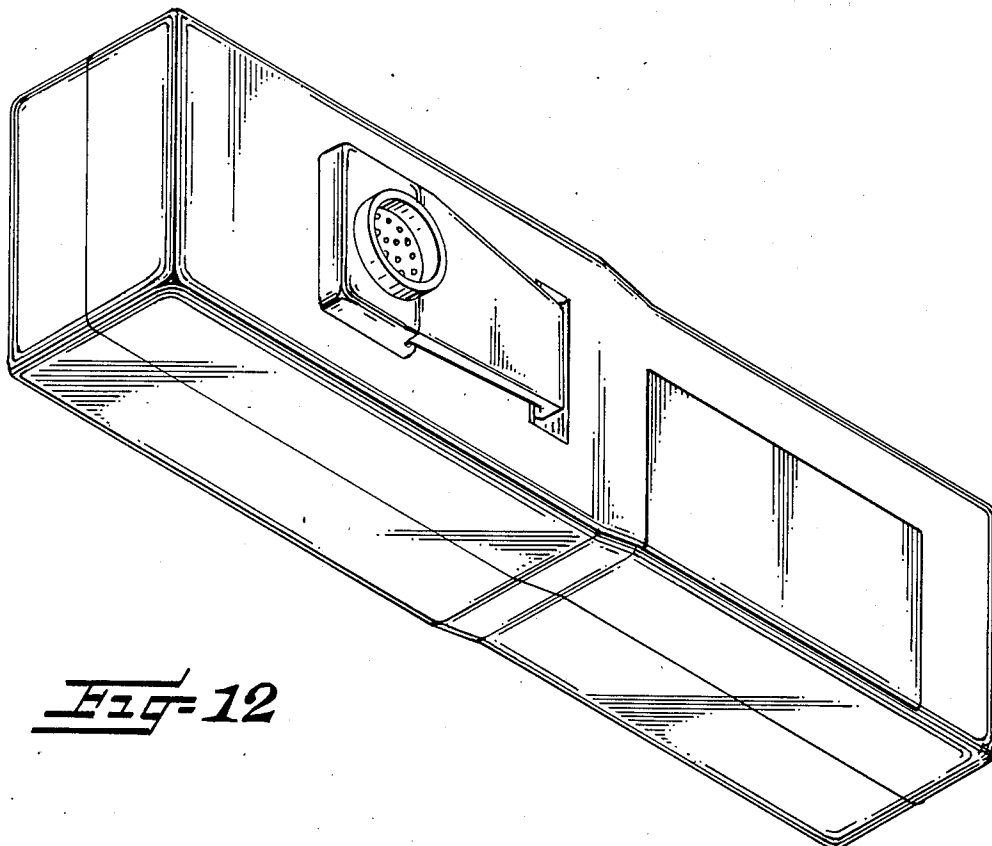

FIG-12

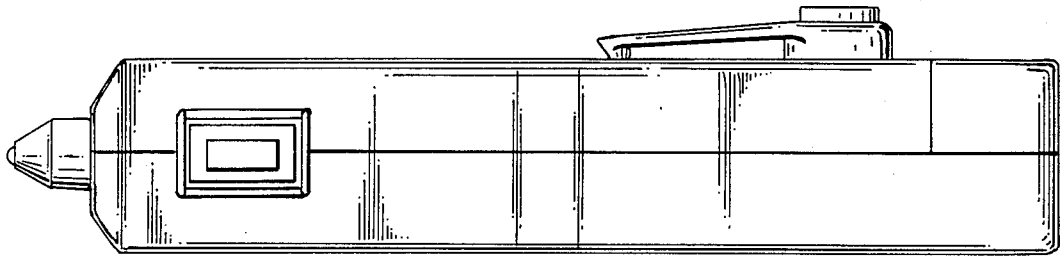

FIG-13

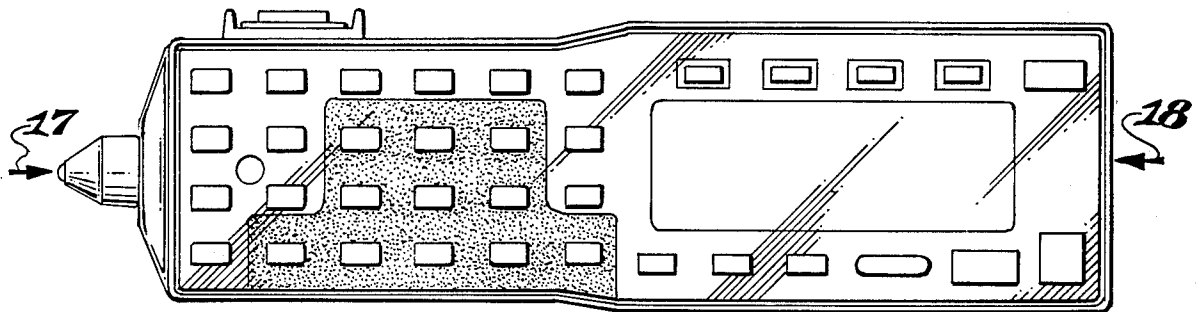

FIG-14

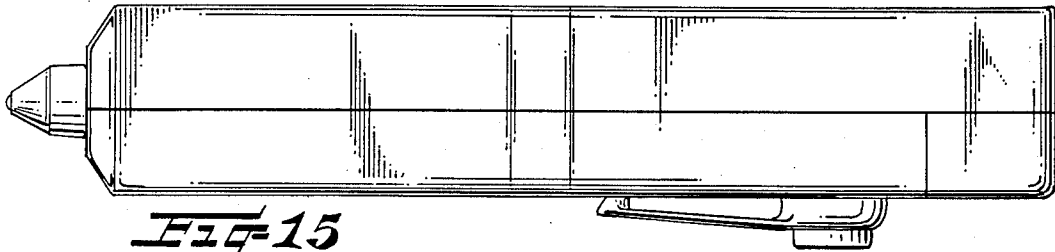

FIG-15

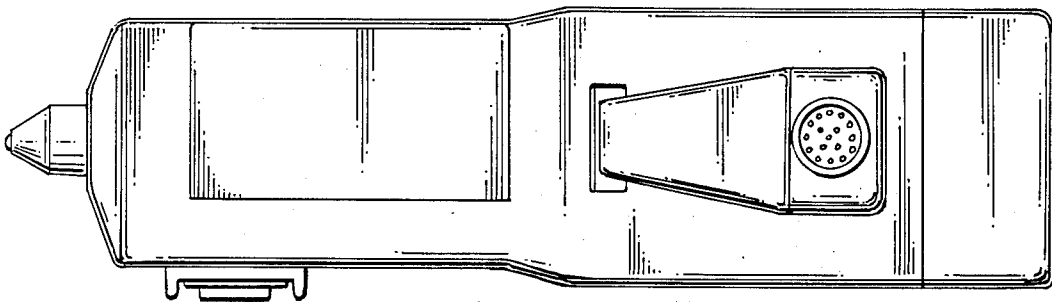

FIG-16

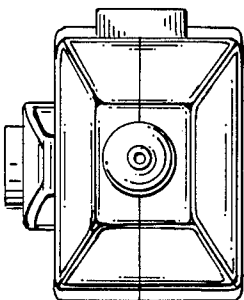

FIG-17

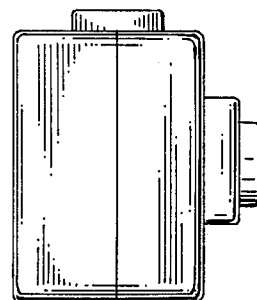

FIG-18

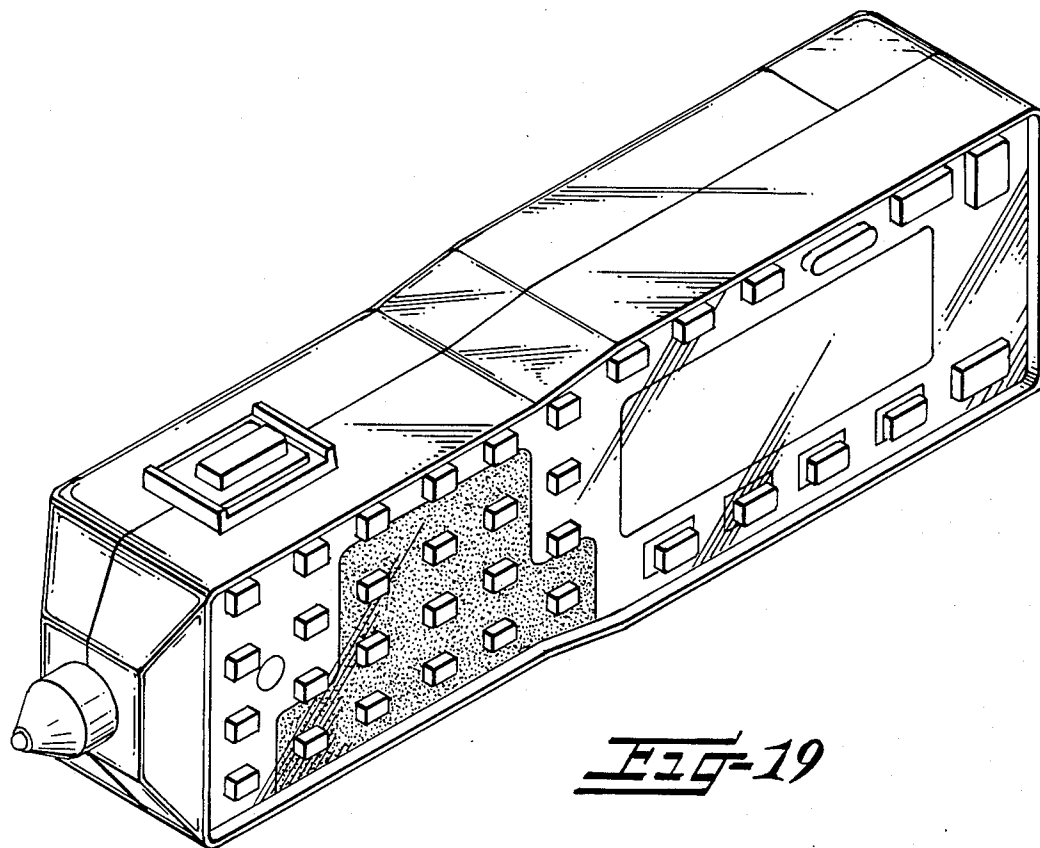

FIG-19

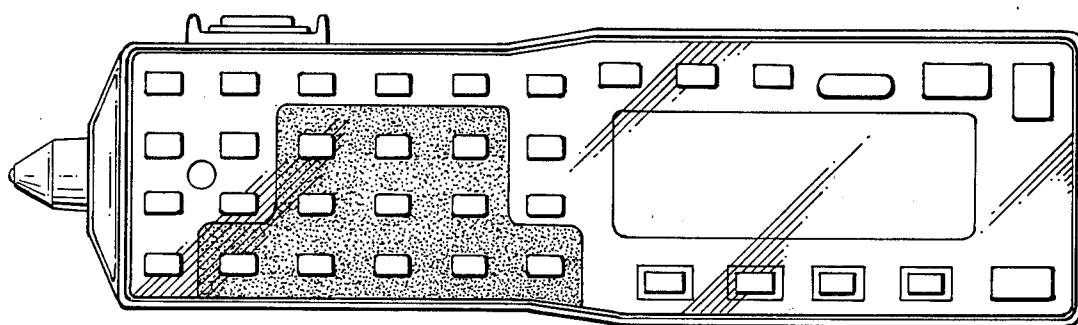

FIG-20