



US00D750392S

(12) **United States Design Patent**
Wilkens

(10) **Patent No.:** **US D750,392 S**

(45) **Date of Patent:** **** Mar. 1, 2016**

(54) **AIRCRAFT SEAT**

(71) Applicant: **Encore Interiors, Inc.**, Irvine, CA (US)

(72) Inventor: **Jeremy Wilkens**, Newport Beach, CA (US)

(73) Assignee: **Encore Interiors, Inc.**, Irvine, CA (US)

(**) Term: **14 Years**

(21) Appl. No.: **29/464,754**

(22) Filed: **Aug. 20, 2013**

(51) **LOC (10) Cl.** **06-01**

(52) **U.S. Cl.**
USPC **D6/356**

(58) **Field of Classification Search**
USPC D6/334-336, 342, 356, 360, 367-368, D6/374, 375, 708.21, 716, 716.1-716.7, D6/717
CPC A47C 1/124; A47C 5/043; A47C 7/022; A47C 7/18; A47C 7/40; A47C 7/70; A47C 7/383; A47C 7/543; A62B 7/14; B60N 2/015; B60N 2/22; B60N 2/48; B60N 2/62; B60N 2/66; B60N 2/70; B60N 2/449; B60N 2/4606; B60N 2/4879; B60N 2/4882; B60N 2/067; B60N 2/075; B60N 2/0715; B60N 2/682; B60N 3/004; B60R 7/043; B64D 11/06; B64D 11/0624; B64D 11/0693

See application file for complete search history.

(56) **References Cited**

U.S. PATENT DOCUMENTS

345,710 A 7/1886 Mason
2,619,395 A 11/1952 Kent
D180,710 S * 7/1957 Del Gludice D6/356
3,049,374 A 8/1962 Nance
D198,498 S * 6/1964 Malitte D6/356

D198,783 S * 8/1964 Barecki D6/356
3,333,890 A * 8/1967 Whitwam 297/188.04
3,615,118 A 10/1971 Buxton

(Continued)

FOREIGN PATENT DOCUMENTS

DE 3 433 589 3/1986
EP 0 018 662 11/1980

(Continued)

OTHER PUBLICATIONS

International Search Report and Written Opinion in co-pending Patent Application No. PCT/US2014/033071, mailed Jul. 28, 2014, in 11 pages.

Primary Examiner — Ricky Pham

(74) *Attorney, Agent, or Firm* — Knobbe Martens Olson & Bear LLP

(57) **CLAIM**

I claim the ornamental design for an aircraft seat, as shown and described.

DESCRIPTION

FIG. 1 is a perspective view of an aircraft seat showing an embodiment of my new design;
FIG. 2 is a front view of the embodiment of FIG. 1;
FIG. 3 is a rear view of the embodiment of FIG. 1;
FIG. 4 is a right side view of the embodiment of FIG. 1;
FIG. 5 is a left side view of the embodiment of FIG. 1;
FIG. 6 is a top view of the embodiment of FIG. 1; and,
FIG. 7 is a bottom view of the embodiment of FIG. 1.
The broken lines in FIGS. 1-7 having a dash-dash configuration are for illustrative purposes only and form no part of the claimed design.

1 Claim, 5 Drawing Sheets

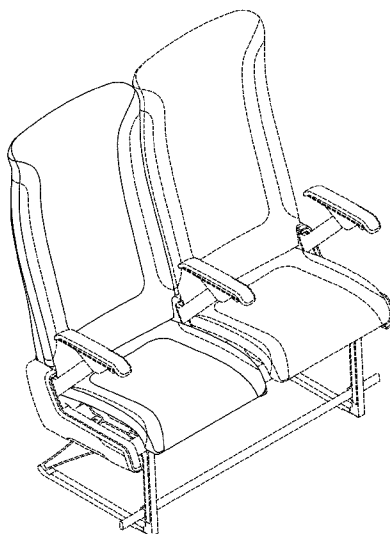

(56)

References Cited

U.S. PATENT DOCUMENTS

3,795,422 A 3/1974 Robinson et al.
D239,148 S * 3/1976 Smith et al. D6/342
4,097,088 A 6/1978 Meiller
D250,071 S * 10/1978 Dickerson D6/356
D257,707 S * 12/1980 Marrujo D6/342
4,307,913 A 12/1981 Spiegelhoff
D267,372 S * 12/1982 Long et al. D6/356
D268,972 S * 5/1983 White D6/356
4,526,421 A * 7/1985 Brennan et al. 297/232
4,726,621 A 2/1988 Muller
4,836,602 A 6/1989 D'Almada Remedios et al.
D336,379 S * 6/1993 Veneruso D6/356
5,375,907 A 12/1994 Rogers et al.
5,507,556 A 4/1996 Dixon
5,597,139 A 1/1997 Beroth
5,611,503 A 3/1997 Brauer
5,695,240 A 12/1997 Luria
5,720,515 A 2/1998 Haffner
5,730,458 A 3/1998 Byon
6,076,768 A 6/2000 Durand et al.
6,092,705 A 7/2000 Meritt
D430,761 S * 9/2000 Haney D6/716.2
6,176,547 B1 1/2001 Francois et al.
D441,210 S * 5/2001 Mitjans D6/368
6,450,571 B1 9/2002 Canni et al.
6,494,533 B1 12/2002 Bohler
6,592,179 B1 7/2003 Miyazaki
6,644,738 B2 * 11/2003 Williamson 297/232
D486,330 S * 2/2004 Laming et al. D6/716.3
6,739,552 B2 5/2004 Sankrithi et al.
6,761,398 B2 7/2004 Bentley
D505,796 S * 6/2005 Johnson D6/356
6,994,401 B1 2/2006 Fischer et al.
7,066,551 B2 * 6/2006 Johnson 297/452.18
7,073,449 B2 7/2006 Pipkin
7,296,858 B2 11/2007 Ruspa
7,500,716 B2 3/2009 Guerin et al.
7,611,198 B2 11/2009 Schweizer
7,621,593 B2 11/2009 Dickinson
D605,863 S * 12/2009 Aruga et al. D6/356
D606,344 S * 12/2009 Aruga et al. D6/717
D632,105 S * 2/2011 Aruga et al. D6/716
7,971,929 B2 7/2011 Kennard et al.
8,020,936 B2 9/2011 Asami et al.
8,028,958 B2 10/2011 Kneller et al.
8,141,948 B2 3/2012 Cassellia et al.
8,146,999 B2 4/2012 Ferguson et al.

8,186,760 B2 5/2012 Kneller et al.
D665,182 S * 8/2012 Hilton et al. D6/360
8,393,680 B2 * 3/2013 Zimmermann et al. 297/257
D686,422 S * 7/2013 Robinson D6/356
8,613,479 B2 12/2013 Schurg et al.
8,636,003 B2 * 1/2014 Deutscher et al. 128/204.18
8,667,904 B2 3/2014 Pajic
8,702,163 B2 4/2014 Westerink
D707,999 S * 7/2014 Takashi et al. D6/716.4
8,763,976 B1 7/2014 Jachim
8,826,830 B2 9/2014 Pajic
8,851,565 B2 10/2014 Hontz et al.
8,905,470 B2 12/2014 Shih et al.
8,934,063 B2 1/2015 Boyer, Jr.
8,936,307 B2 1/2015 Heredia
D723,819 S * 3/2015 Takahashi et al. D6/356
D723,822 S * 3/2015 Cai et al. D6/356
D724,338 S * 3/2015 Nicholas D6/356
D724,339 S * 3/2015 Cai et al. D6/356
D725,927 S * 4/2015 Carter D6/356
2003/0094542 A1 * 5/2003 Williamson 244/122 R
2003/0094837 A1 * 5/2003 Williamson et al. 297/163
2003/0094842 A1 * 5/2003 Williamson 297/362.13
2004/0021349 A1 * 2/2004 Longtin et al. 297/217.3
2004/0046430 A1 * 3/2004 Plant et al. 297/248
2004/0099766 A1 * 5/2004 Pratt, Jr. 244/118.6
2004/0212228 A1 * 10/2004 Skelly et al. 297/217.3
2005/0194828 A1 * 9/2005 Johnson et al. 297/411.32
2007/0200414 A1 8/2007 Pozzi
2007/0283855 A1 12/2007 Pozzi
2011/0174926 A1 7/2011 Margis et al.
2013/0002001 A1 1/2013 Allen et al.
2013/0080357 A1 3/2013 Boren et al.
2013/0093220 A1 4/2013 Pajic
2013/0147240 A1 6/2013 Lee
2013/0314861 A1 11/2013 Burford
2013/0327255 A1 12/2013 Pajic
2014/0159441 A1 6/2014 Philipzik et al.
2014/0175843 A1 6/2014 Westerink et al.
2014/0284972 A1 9/2014 Riedel et al.
2014/0284973 A1 9/2014 Wolgast et al.
2014/0333100 A1 11/2014 Wilkens

FOREIGN PATENT DOCUMENTS

EP 2 110 313 10/2009
EP 2 746 158 6/2014
FR 2 577 776 8/1986
WO WO 02/32268 4/2002

* cited by examiner

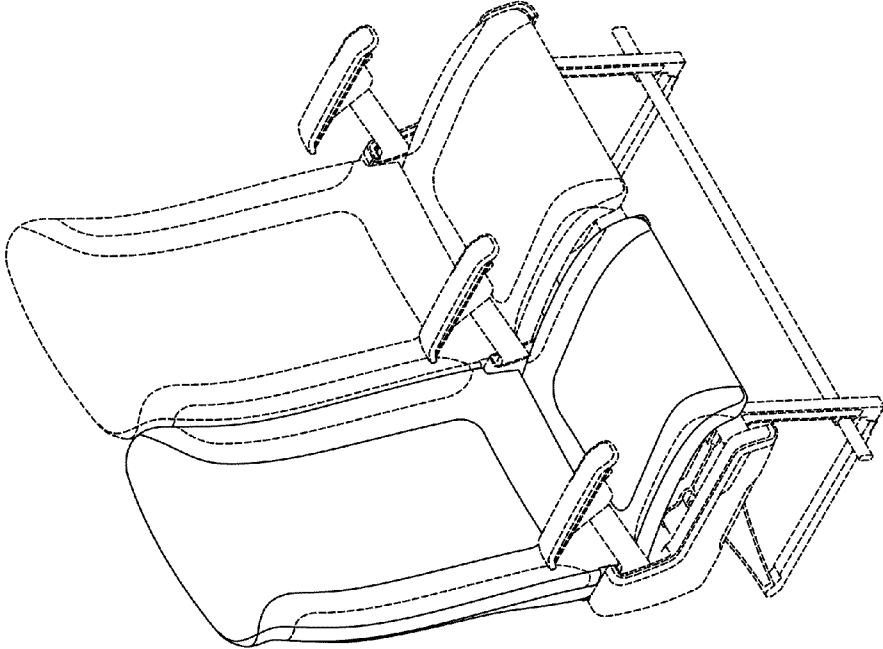

FIG. 1

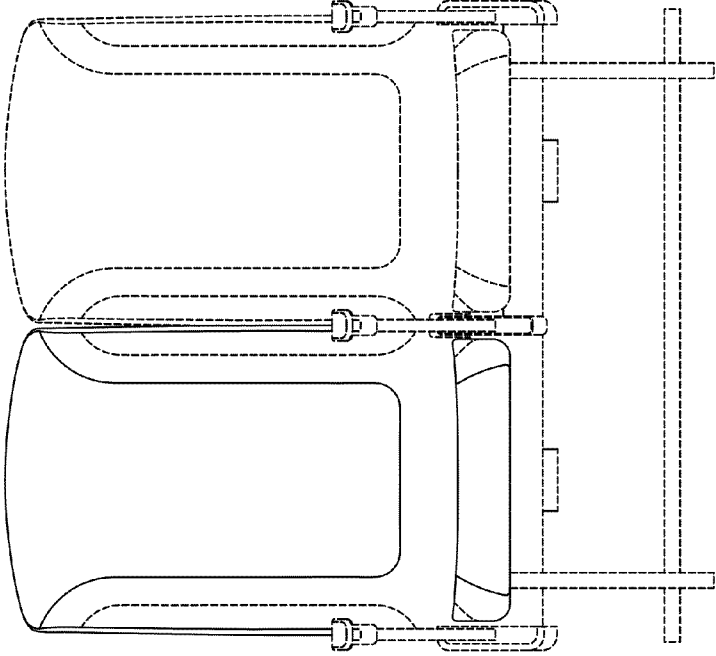

FIG. 2

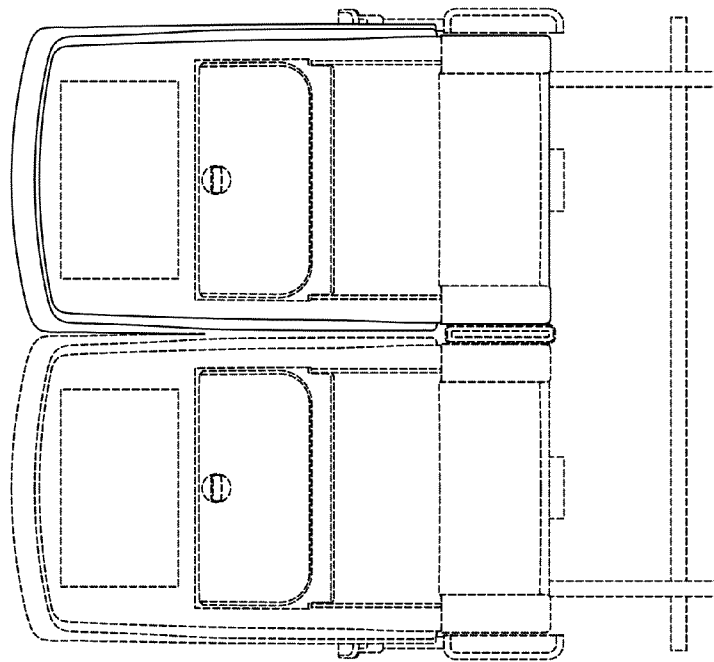

FIG. 3

FIG. 5

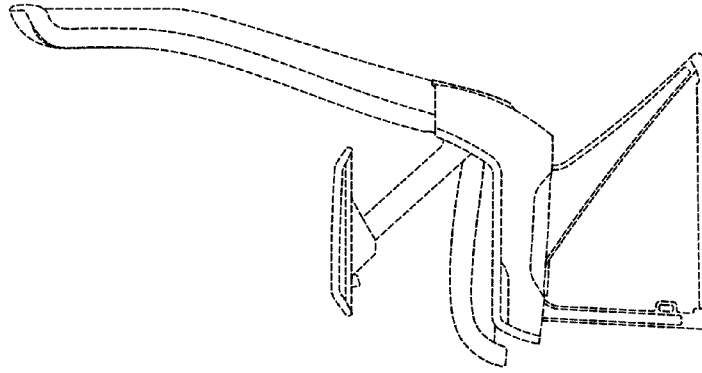
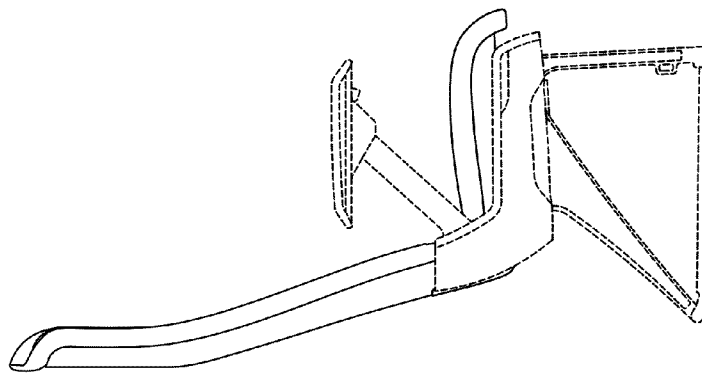

FIG. 4



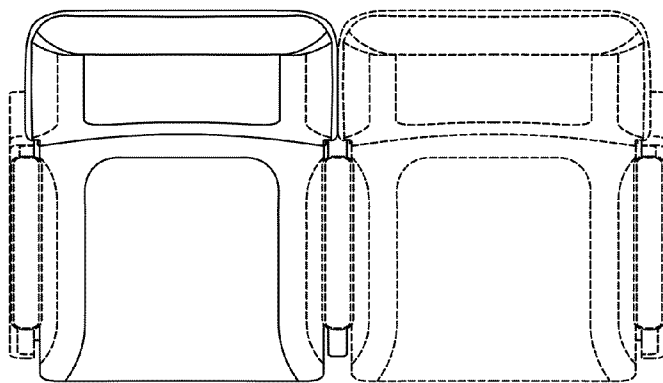

FIG. 6

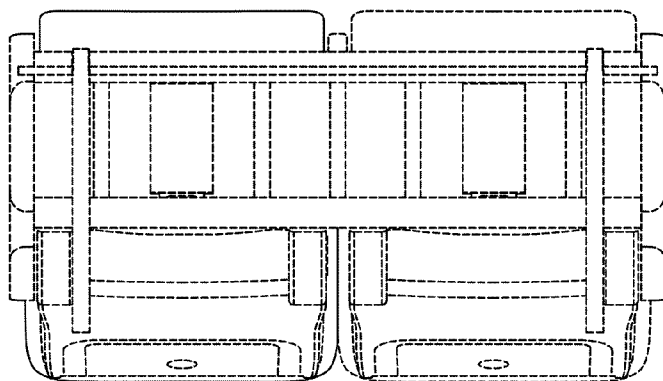

FIG. 7