

Aug. 27, 1929.

A. C. RECKER

1,725,883

CONNECTER FOR ATTACHING ELECTRIC CABLES OR
CONDUITS TO OUTLET BOXES AND THE LIKE
Filed Feb. 10, 1928

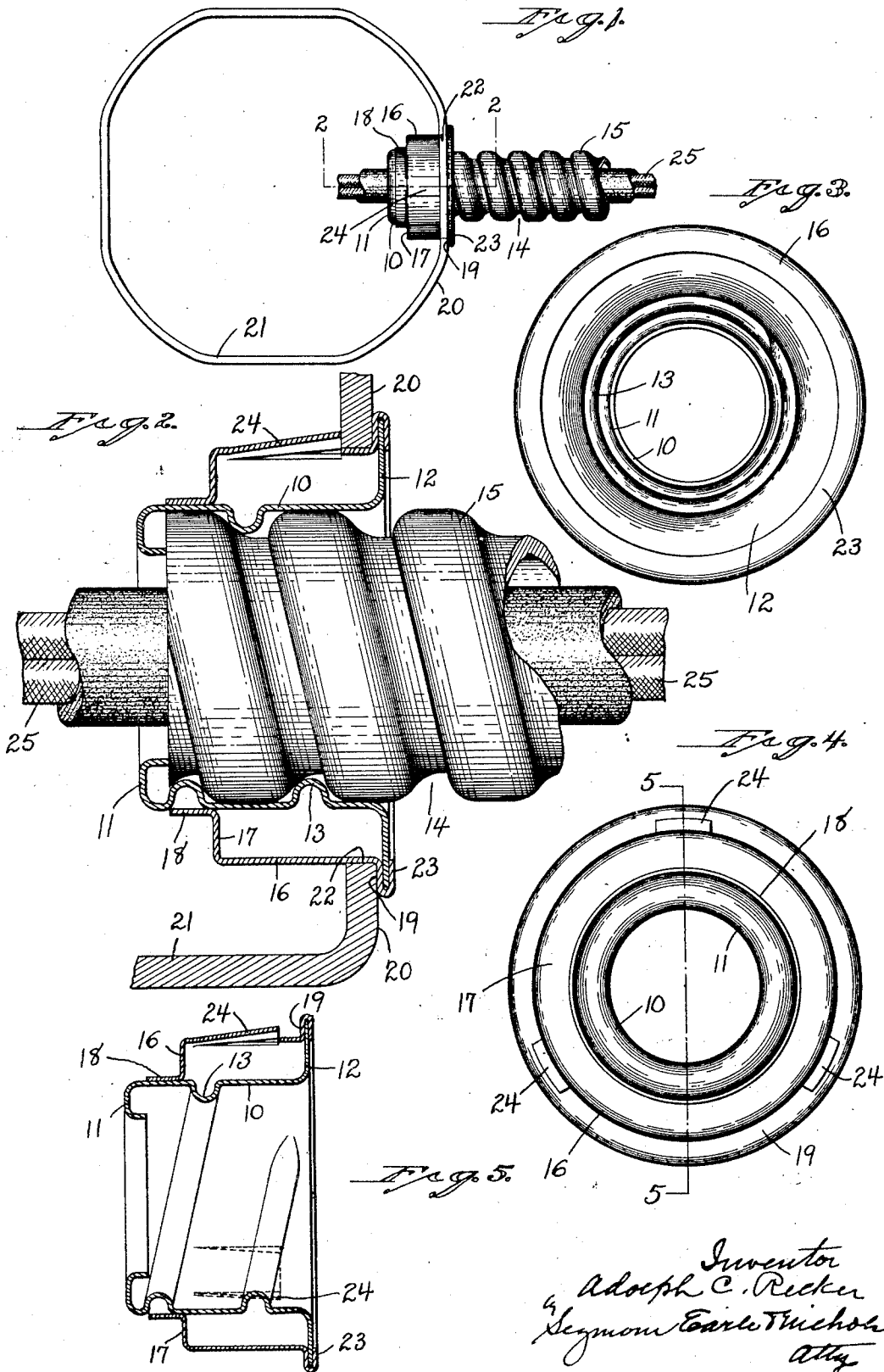

Inventor
Adolph C. Recker
by
Seymour Earl Nichols
Atty

UNITED STATES PATENT OFFICE.

ADOLPH C. RECKER, OF OAKVILLE, CONNECTICUT, ASSIGNOR TO CHASE COMPANIES INC., OF WATERBURY, CONNECTICUT, A CORPORATION.

CONNECTER FOR ATTACHING ELECTRIC CABLES OR CONDUITS TO OUTLET BOXES AND THE LIKE.

Application filed February 10, 1928. Serial No. 253,497.

This invention relates to an improvement in electric cable or conduit connectors, and particularly to connectors for attaching helically-wound flexible metallic cables or conduits to outlet-boxes and the like.

The object of this invention is to produce, at a low cost for manufacture, a simple and convenient connector of the class described, constructed with particular reference to security in use and ease of installation.

With this object in view, my invention consists in a connector for attaching electric cables or conduits to outlet-boxes and the like, characterized in its preferred form by its provision with a socket for the reception of one end of a cable or conduit; means for holding the said cable or conduit in the said socket; a stop for engaging the outer face of the wall of an outlet-box adjacent an opening therein; and one or more spring retaining fingers for engaging the inner face of the said wall, adjacent the opening therein, and sloping outward and toward the said stop; whereby the said spring retaining-fingers will first yield to permit the passage of the forward end of the connector through the said opening and then automatically spring outward to engage the inner face of the side-wall to couple the said connector and cable to the outlet-box.

My invention further consists in a connector characterized as above and having the cable or conduit-receiving socket thereof provided internally with threads or thread-segments for interengaging with the helical grooves of flexible metallic cables or conduits to hold the same in place in the said socket.

In the accompanying drawings:

Fig. 1 is a top or plan view of an outlet-box showing a flexible metallic cable or conduit attached thereto by means of my improved connector;

Fig. 2 is an enlarged scale view in vertical section on the line 2—2 of Fig. 1;

Fig. 3 is a rear end view of my improved connector detached.

Fig. 4 is a view looking toward the forward end thereof; and

Fig. 5 is a sectional view thereof on the line 5—5 of Fig. 4.

In the type of connector herein chosen for the illustration of my invention, I employ a

tubular sheet-metal thimble or socket-member 10 formed at its forward end with an inwardly-turned annular bead-like guard-flange 11 substantially semicircular in cross-section, and at its rear end with a flange 12 outwardly-turned at a right angle with respect to its tubular body-portion. The interior of the tubular body-portion of the said socket-member 10 is provided with an inwardly-projecting thread-like helical rib 13 adapted to fit into the helical groove 14 of a flexible metallic cable or conduit 15 of ordinary and well-known characteristics.

Imposed upon the socket-member 10 just above described is a tubular shell-member 16 formed of sheet-metal and having its forward end turned inward at a right angle to form a transverse wall 17 terminating in a short annular skirt 18 snugly fitting the exterior of the socket-member 10 aforesaid, as clearly shown in Figs. 2 and 5. The rear end of the said shell 16 is turned radially outward at a right angle to form an annular stop-shoulder 19 adapted to engage the outer face of the side-wall 20 of an outlet-box 21 of ordinary form, adjacent the usual opening 22 therein. The metal of the outer end of the shoulder 19 is bent rearwardly and radially inward as at 23 over the outwardly-turned flange 12 of the socket-member 10 to clamp the same against the said shoulder and thus firmly unite the socket-member 10 and the shell 16 into a unitary structure.

For the purpose of retaining the socket- and shell-members as a unit in the opening 22 of the outlet-box 20 against axial rearward displacement, I strike outward from the said shell-member, at equidistant points thereon, three corresponding rearwardly and outwardly-inclined spring retaining-fingers 24, which are adapted at their free rear ends to engage the inner face of the wall 20 of the outlet-box 21 adjacent the opening 22 therein.

In the use of my improved connector, the same is preferably first secured upon the end of the flexible metallic cable or conduit 15 by turning it thereon to engage its thread-like helical ribs 13 with the helical groove 14 of the said cable or conduit and until the end of the latter has been brought into engagement with the bead-like guard-flange 11 intumed from the forward end of the

socket-member aforesaid. The connector is now introduced into the opening 22 in the wall 20 of the outlet-box, with the effect of causing its spring retaining-fingers 24 to yield and to ultimately snap outward to engage with the inner face of the said wall adjacent the opening 22 therein at about the time that the stop-shoulder 19 engages with the outer face of the said wall, with the effect of firmly retaining the connector, and hence the cable or conduit, in place in the outlet-box against axial withdrawal therefrom. The stop-shoulder 19 at this time serves to prevent inward movement in the opposite direction of the connector and cable.

The flexible cable or conduit 15, as before stated, is of ordinary and well-known form and forms a protection for electric conductors 25, more or less in number, which may be permanently installed therein, as is sometimes the practice, or formed independently and threaded therethrough. In either event, the inwardly-turned bead-like guard-flange 11 of the socket-member 10 forms a stop to position the end of the conduit in the said socket and also forms a rounded guard to prevent the rough edges of the conduit from abraiding the insulation of the conductors 25.

The spring retaining-fingers 24, preferably and as shown, are cut free of the shell-member 16 on three of their sides, but it is obvious, without further illustration, that it is unnecessary that they be so cut in order to measurably perform their function.

I claim:

1. A connector for attaching electric cables or conduits to outlet-boxes and the like, comprising a tubular sheet-metal socket-member provided with a socket for the reception of the end of a cable or conduit and with means projecting inwardly into the said socket for holding the same in place therein; a tubular sheet-metal shell-member imposed over the said socket-member and having a stop for engaging the outer face of the wall of an outlet-box adjacent an opening therein; and one or more spring retaining-fingers struck outward from the said shell-member for engaging the inner face of the said wall adjacent the opening therein and sloping outward and toward the said stop; whereby the said spring retaining-fingers will first yield to permit the passage of the forward end of the connector through the said opening and then automatically spring outward to engage the inner face of the side-wall to couple the said connector and cable to the outlet-box.

2. A connector for attaching electric cables or conduits to outlet-boxes and the like, com-

prising a socket-member provided with a socket for the reception of the end of a cable or conduit and with a helical rib for holding the same in place therein; a shell-member imposed over the said socket-member and having a stop for engaging the outer face of the wall of an outlet-box adjacent an opening therein; and one or more spring retaining-fingers struck outward from the said shell-member for engaging the inner face of the said wall adjacent the opening therein and sloping outward and toward the said stop; whereby the said spring retaining-fingers will first yield to permit the passage of the forward end of the connector through the said opening and then automatically spring outward to engage the inner face of the side-wall to couple the said connector and cable to the outlet-box.

3. A connector for attaching electric cables or conduits to outlet-boxes and the like, comprising a tubular sheet-metal socket-member provided with a socket for the reception of the end of a cable or conduit, means projecting inwardly into the said socket for holding the same in place therein, and a guard-flange for positioning the said cable or conduit and preventing the abrasion of conductors passing therethrough; a tubular sheet-metal shell-member imposed over the said socket-member and having a stop for engaging the outer face of the wall of an outlet-box adjacent an opening therein; and one or more spring retaining-fingers struck outward from the said shell-member for engaging the inner face of the said wall adjacent the opening therein and sloping outward and toward the said stop; whereby the said spring retaining-fingers will first yield to permit the passage of the forward end of the connector through the said opening and then automatically spring outward to engage the inner face of the side-wall to couple the said connector and cable to the outlet-box.

4. A connector for attaching electric cables or conduits to outlet-boxes and the like, comprising a tubular sheet-metal socket-member provided with a socket for the reception of the end of a conduit or cable and with means projecting inwardly into the said socket for engaging and holding the conduit in place therein; a tubular sheet-metal shell-member sleeved over the said socket-member and having resilient projections struck outward therefrom for engaging the inner face of the wall of an outlet-box adjacent an opening therein.

In testimony whereof, I have signed this specification.

ADOLPH C. RECKER.