



US006286655B1

(12) **United States Patent**  
**Grubbs et al.**

(10) **Patent No.:** **US 6,286,655 B1**  
(45) **Date of Patent:** **Sep. 11, 2001**

- (54) **INCLINED CONVEYOR**
- (75) Inventors: **Michael R. Grubbs**, Nashville; **Garry R. Kenny**, College Grove, both of TN (US)
- (73) Assignee: **Advanced Sorting Technologies, LLC**, Nashville, TN (US)
- (\* ) Notice: Subject to any disclaimer, the term of this patent is extended or adjusted under 35 U.S.C. 154(b) by 0 days.

4,124,168	11/1978	Bialski et al. ....	241/14
4,131,540	12/1978	Husome et al. .	
4,176,750	12/1979	Holmes .	
4,207,177	6/1980	Block .....	209/44.2
4,225,427	9/1980	Schnell .....	209/44.1
4,231,526	11/1980	Ortner et al. ....	241/28
4,352,430	10/1982	Maier et al. .	
4,440,284	4/1984	DeWolfson .....	194/4 R
4,505,371	3/1985	Krueger et al. .	
4,533,053	8/1985	Kenny et al. ....	209/636
4,533,054	8/1985	Sommer, Jr. et al. ....	209/687
4,541,530	9/1985	Kenny et al. ....	209/571

(List continued on next page.)

- (21) Appl. No.: **09/302,706**
- (22) Filed: **Apr. 29, 1999**
- (51) **Int. Cl.**<sup>7</sup> ..... **B65G 47/31**
- (52) **U.S. Cl.** ..... **198/462.2**; 198/462.1; 198/462.3; 271/195
- (58) **Field of Search** ..... 198/462.1, 462.2, 198/462.3; 271/195, 202

**FOREIGN PATENT DOCUMENTS**

2109021	4/1994	(CA) .
3615644A 1	11/1987	(DE) .

(List continued on next page.)

**OTHER PUBLICATIONS**

Catalog of Magnetic Separation Systems, INC. entitled "Systems For Separation and Sensing"(undated, but admitted to be prior art).

(List continued on next page.)

(56) **References Cited**  
**U.S. PATENT DOCUMENTS**

1,035,345	8/1912	Heess .	
1,497,438	* 6/1924	Gottschalk .....	198/462.3
1,547,743	7/1925	Fowler .	
1,847,263	3/1932	Sandberg .	
1,847,265	3/1932	Sandberg .	
2,897,952	8/1959	Buccicone .	
3,101,832	8/1963	Wyle et al. .	
3,185,286	5/1965	Koplin .	
3,198,352	8/1965	Puechberty .	
3,227,263	1/1966	Kastenbein .	
3,352,404	11/1967	Settembrini .	
3,471,013	10/1969	Haver .	
3,603,645	9/1971	Hardy .	
3,650,369	3/1972	Vergobbi .	
3,747,755	7/1973	Senturia et al. ....	209/111.5
3,800,936	4/1974	Anfossi .	
3,870,967	3/1975	Herkes .	
4,069,005	1/1978	Sommer, Jr. et al. ....	209/212
4,093,062	6/1978	Sjögren .	
4,094,772	6/1978	Hillekamp et al. ....	2009/12
4,102,056	7/1978	Angelo et al. .	

*Primary Examiner*—Christopher P. Ellis  
*Assistant Examiner*—Gene O. Crawford  
(74) *Attorney, Agent, or Firm*—Waddey & Patterson Lucian Wayne Beavers

(57) **ABSTRACT**

A paper handling system includes first and second inclined conveyors. The first inclined conveyor operates at a first speed and has an output end. The second inclined conveyor operates at a second speed and is operably positioned to receive paper output from the first inclined conveyor. The second speed is greater than the first speed. The inclined conveyors are preferably inclined at an angle in the range from 15° to 35°. By transporting the paper up the inclined conveyors, upper layers of paper are allowed to slide down over lower layers of paper thereby creating a thinner stream of paper.

**3 Claims, 14 Drawing Sheets**

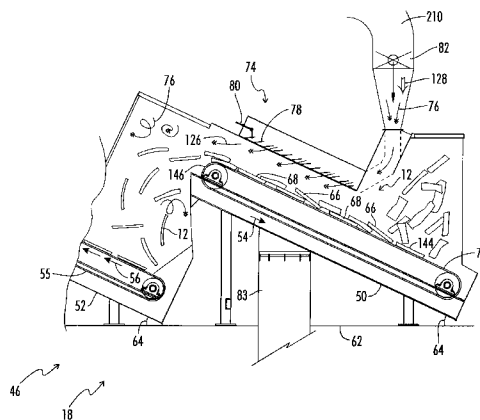

U.S. PATENT DOCUMENTS

4,542,689	9/1985	Trolle	100/215	5,481,864	1/1996	Wright	.
4,609,108	9/1986	Hristozov et al.	.	5,497,871	3/1996	Ciolkevich	.
4,632,320	12/1986	Holz et al.	241/46.17	5,501,344	3/1996	Kaiser et al.	.
4,657,144	4/1987	Martin et al.	.	5,512,758	4/1996	Kobayashi et al.	.
4,667,953	* 5/1987	Hirakawa et al.	271/202 X	5,531,331	7/1996	Barnett	.
4,699,510	10/1987	Alguard	.	5,533,628	7/1996	Tao	.
4,718,559	1/1988	Kenny et al.	209/571	5,555,984	9/1996	Sommer, Jr. et al.	.
4,760,925	8/1988	Stehle et al.	209/616	5,632,381	5/1997	Thust et al.	.
4,844,351	7/1989	Holloway	241/19	5,675,416	10/1997	Campbell et al.	.
4,909,930	3/1990	Cole	.	5,695,035	12/1997	Fukushima et al.	.
4,919,534	4/1990	Reed	.	5,789,741	8/1999	Kinter et al.	.
4,929,342	5/1990	Johnston	209/12	5,794,788	8/1998	Massen	.
5,022,644	* 6/1991	Burge	271/202 X	5,797,327	* 8/1998	Gieser et al.	271/195 X
5,024,335	6/1991	Lundell	209/618	5,799,105	8/1998	Tao	.
5,048,674	9/1991	Wilbur et al.	.	5,799,801	9/1998	Clark et al.	.
5,060,870	10/1991	Trezek et al.	241/19	5,809,885	* 9/1998	Koch et al.	271/195 X
5,085,325	2/1992	Jones et al.	.	5,813,542	9/1998	Cohn	.
5,091,077	2/1992	Williams	209/12	5,848,706	12/1998	Harris	.
5,092,526	3/1992	Takata	.	5,862,919	1/1999	Eason	.
5,100,005	3/1992	Noble et al.	209/583	5,884,775	3/1999	Campbell	.
5,100,537	3/1992	Krause	209/2	5,901,856	4/1999	Brantley, Jr. et al.	.
5,101,977	4/1992	Roman	209/3	5,915,304	* 6/1999	Stiel	271/195 X
5,111,927	5/1992	Schulze, Jr.	194/209	5,954,206	9/1999	Mallon et al.	.
5,115,144	5/1992	Konishi et al.	.	5,966,217	10/1999	Roe et al.	.
5,115,987	5/1992	Mithal	241/23	5,979,240	11/1999	Rix et al.	.
5,143,308	9/1992	Hally et al.	.	6,010,128	* 1/2000	Loser et al.	271/195 X
5,150,307	9/1992	McCourt et al.	.	6,022,017	* 2/2000	Cummings et al.	271/202 X
5,169,588	12/1992	Estep	264/331.17	6,060,677	5/2000	Ulrichsen et al.	.
5,183,251	* 2/1993	Sardella	271/195 X				
5,190,165	3/1993	Garfield, Jr.	209/655				
5,201,921	4/1993	Luttermann et al.	8/506	3828067A1	2/1990	(DE)	.
5,209,355	5/1993	Mindermann	209/3.1	3926641	2/1991	(DE)	.
5,257,577	11/1993	Clark	100/99	3926641A1	2/1991	(DE)	.
5,297,667	3/1994	Hoffman et al.	198/492	4125045A1	2/1993	(DE)	.
5,299,693	4/1994	Ubaldi et al.	209/3.3	4135394A1	4/1993	(DE)	.
5,301,816	4/1994	Weber et al.	209/616	4305006A1	9/1993	(DE)	.
5,314,072	5/1994	Frankel et al.	209/44.1	4241990C2	6/1994	(DE)	.
5,315,384	5/1994	Heffington et al.	.	WO 96/06690	3/1996	(DE)	.
5,318,172	6/1994	Kenny et al.	209/524	291 959 A2	11/1988	(EP)	.
5,322,152	6/1994	Tommila et al.	194/212	873797	10/1996	(EP)	.
5,333,739	8/1994	Stelte	.	1050992	10/1983	(RU)	.
5,333,797	8/1994	Becker et al.	241/19	1411228	7/1988	(RU)	.
5,335,791	8/1994	Eason	.				
5,339,962	8/1994	Sommer, Jr. et al.	209/576				
5,339,963	8/1994	Tao	.				
5,344,026	9/1994	Booth et al.	.				
5,348,136	9/1994	Kenny et al.	198/443				
5,348,162	9/1994	Wroblewski	209/35				
5,361,913	11/1994	Melchionna	209/583				
5,398,818	3/1995	McGarvey	.				
5,402,264	3/1995	Wilbur et al.	.				
5,419,438	5/1995	Squyres et al.	.				
5,440,127	8/1995	Squyres	.				
5,443,164	8/1995	Walsh et al.	.				
5,460,271	10/1995	Kenny et al.	209/576				
5,464,981	11/1995	Squyres et al.	.				
5,469,973	11/1995	Booth et al.	.				

FOREIGN PATENT DOCUMENTS

OTHER PUBLICATIONS

Brochure entitled "MSS Pen Binary Bottlesort®" (Undated, but admitted to be prior art).

Brochure entitled "MSS Plasticsort™" (Undated, but admitted to be prior art).

Brochure entitled "Machinefabriek Lubo® Mobile Systems" (Undated, but admitted to be prior art) discloses a screening unit having rotating disc on parallel shafts.

Brochure entitled "Machinefabriek Lubo® Projects" (Undated, but admitted to be prior art) discloses a screening unit having rotating discs on parallel shafts.

\* cited by examiner

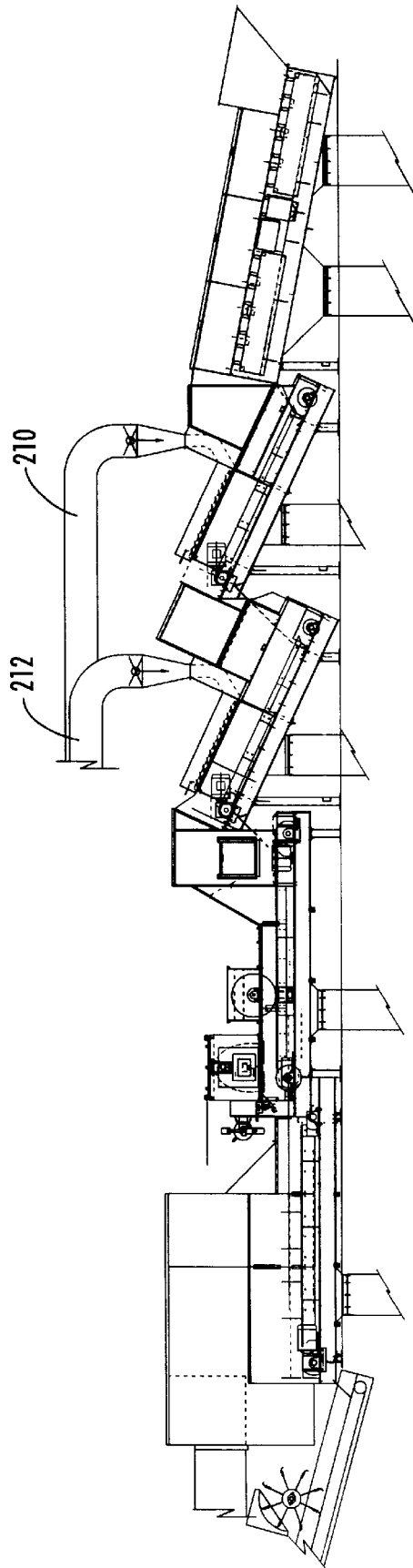

FIG. 1

10

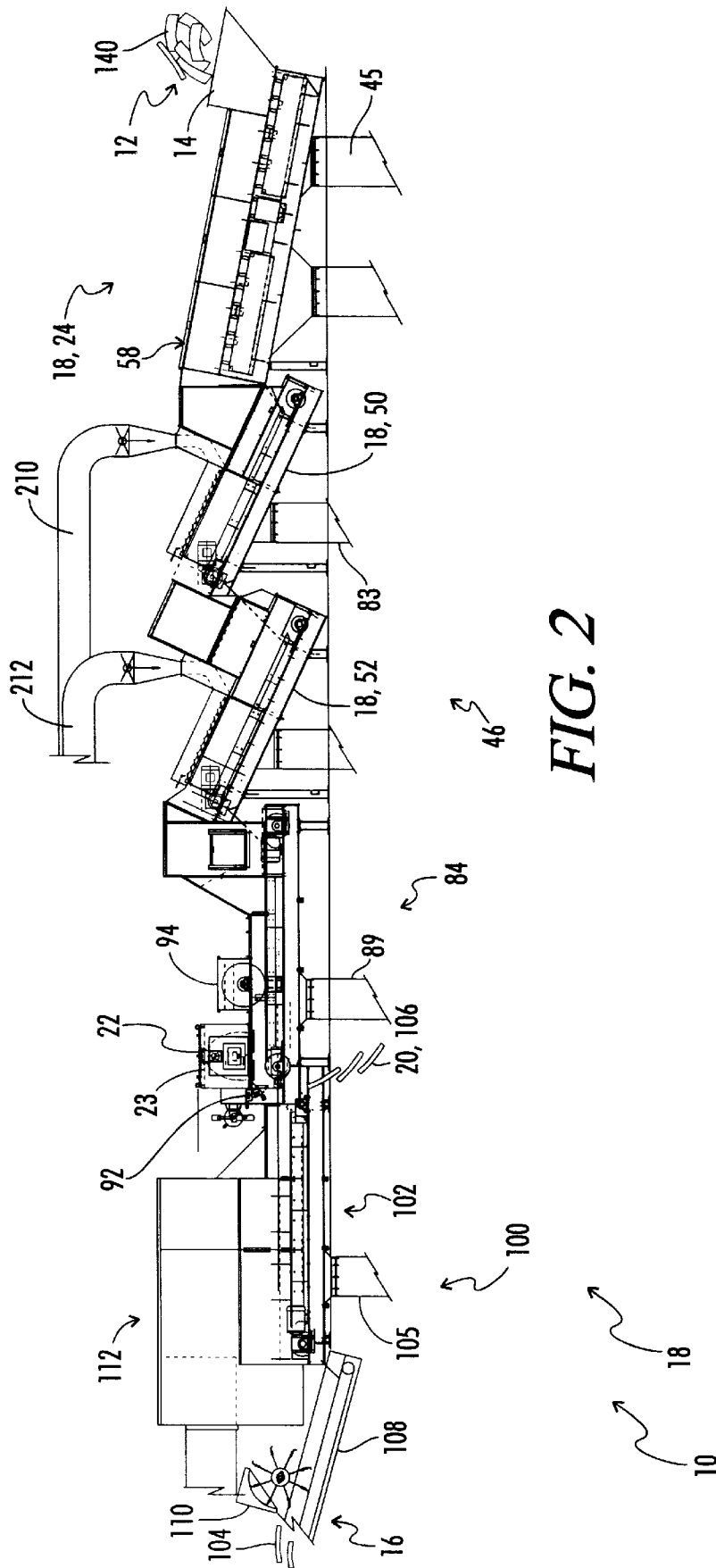

FIG. 2

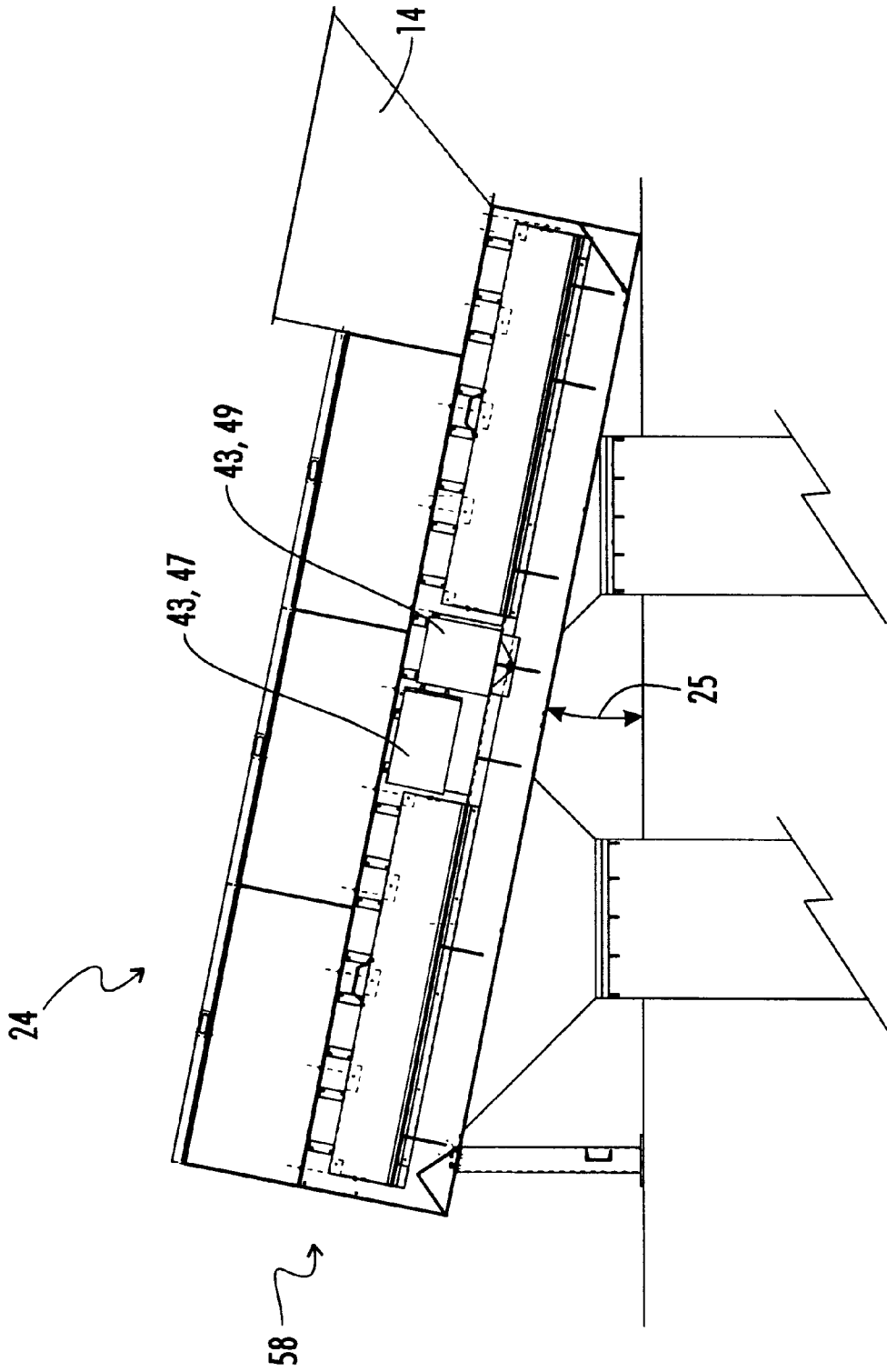

FIG. 3

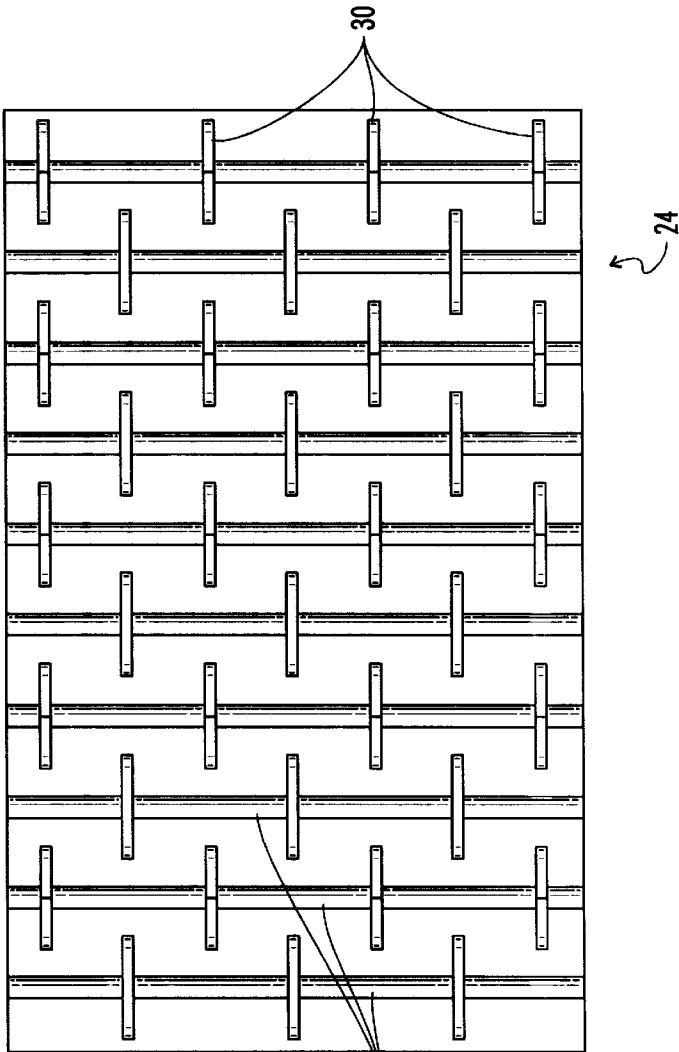

FIG. 4

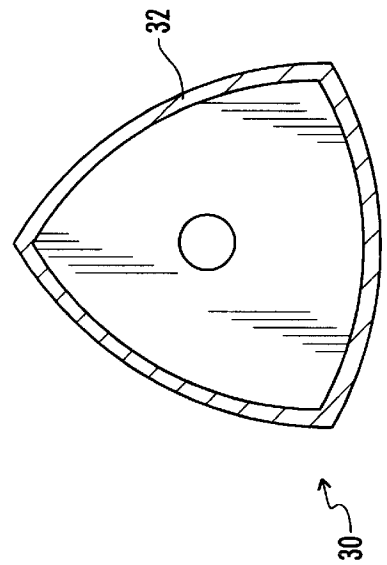

FIG. 5

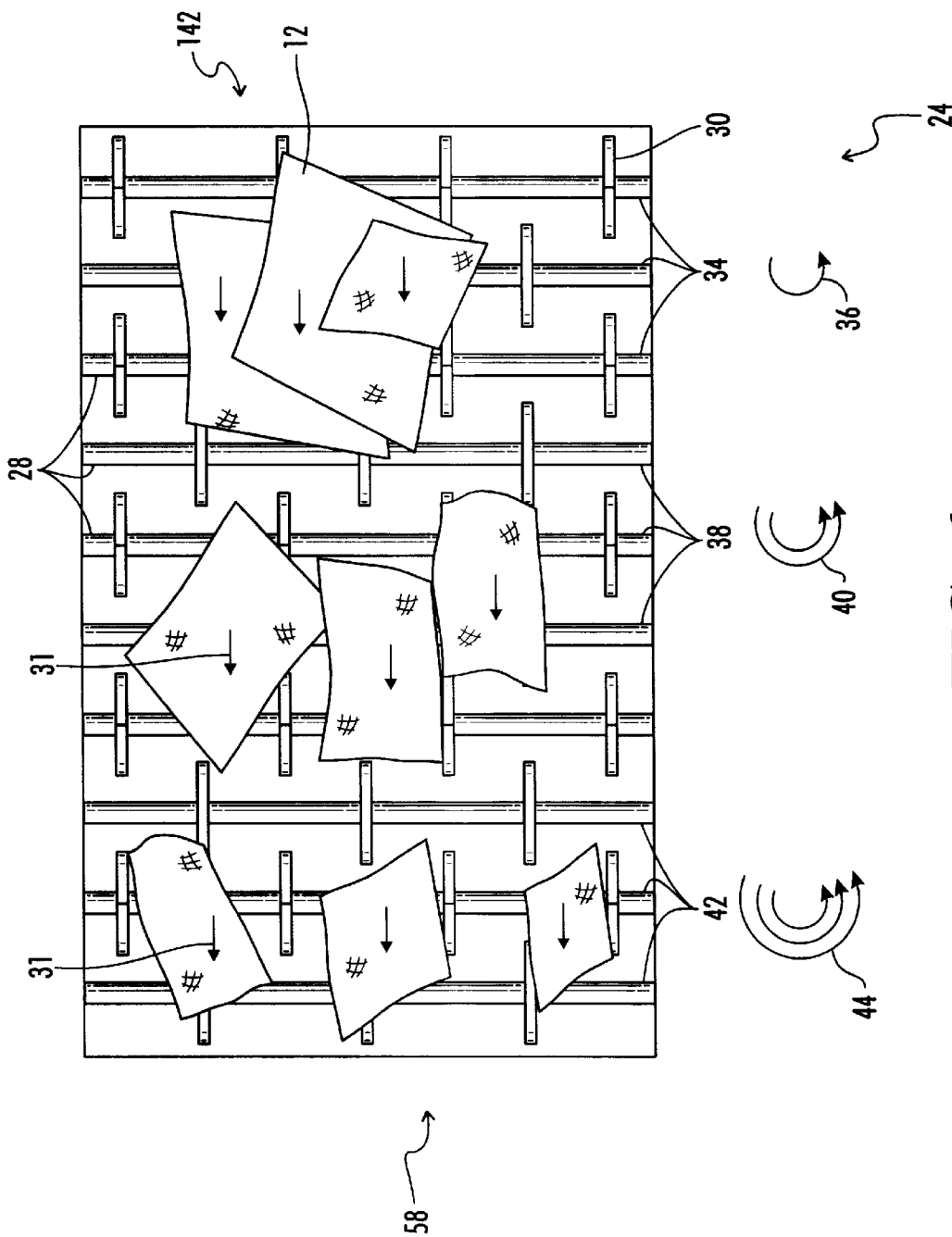

FIG. 6

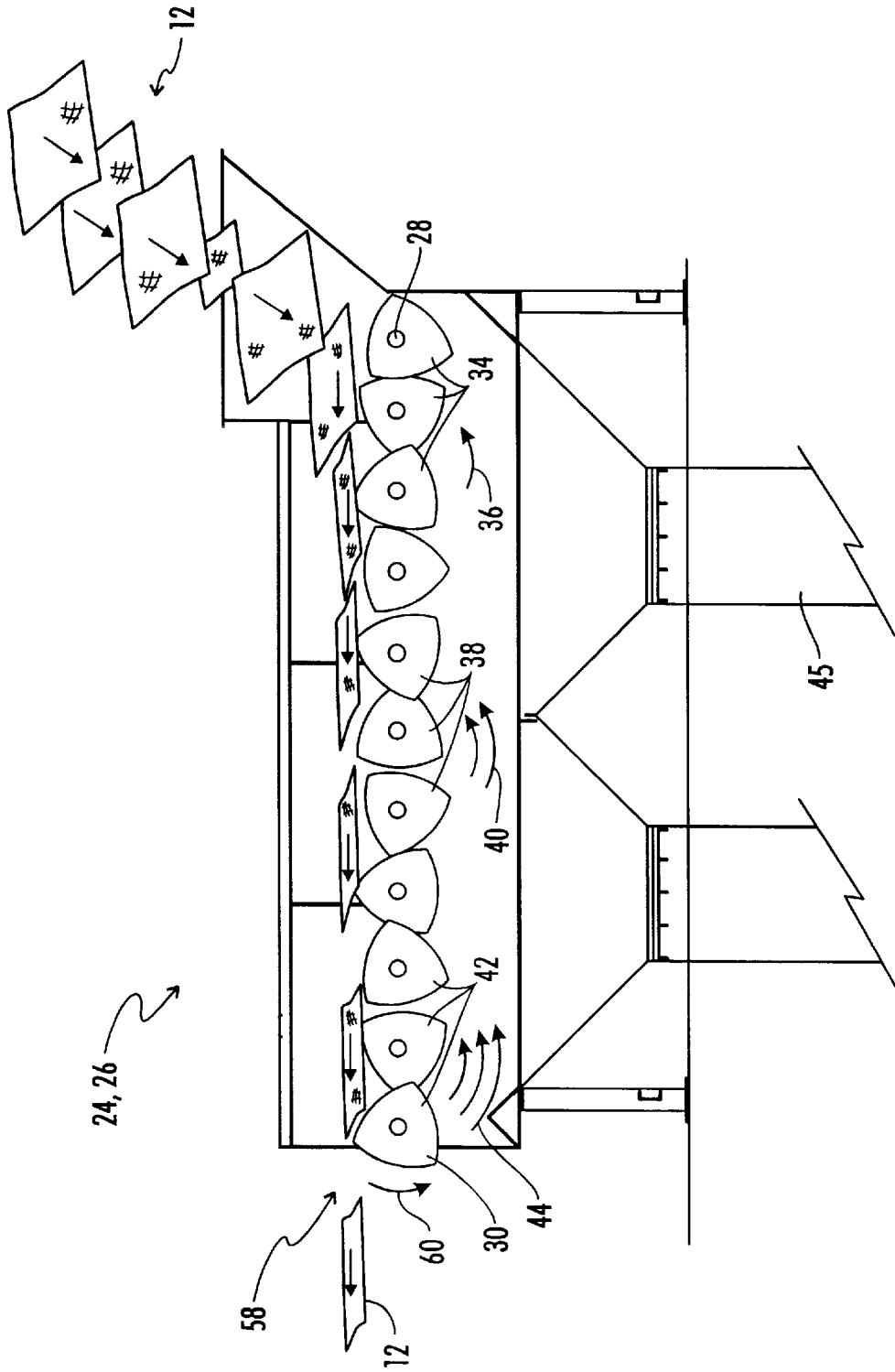

FIG. 7



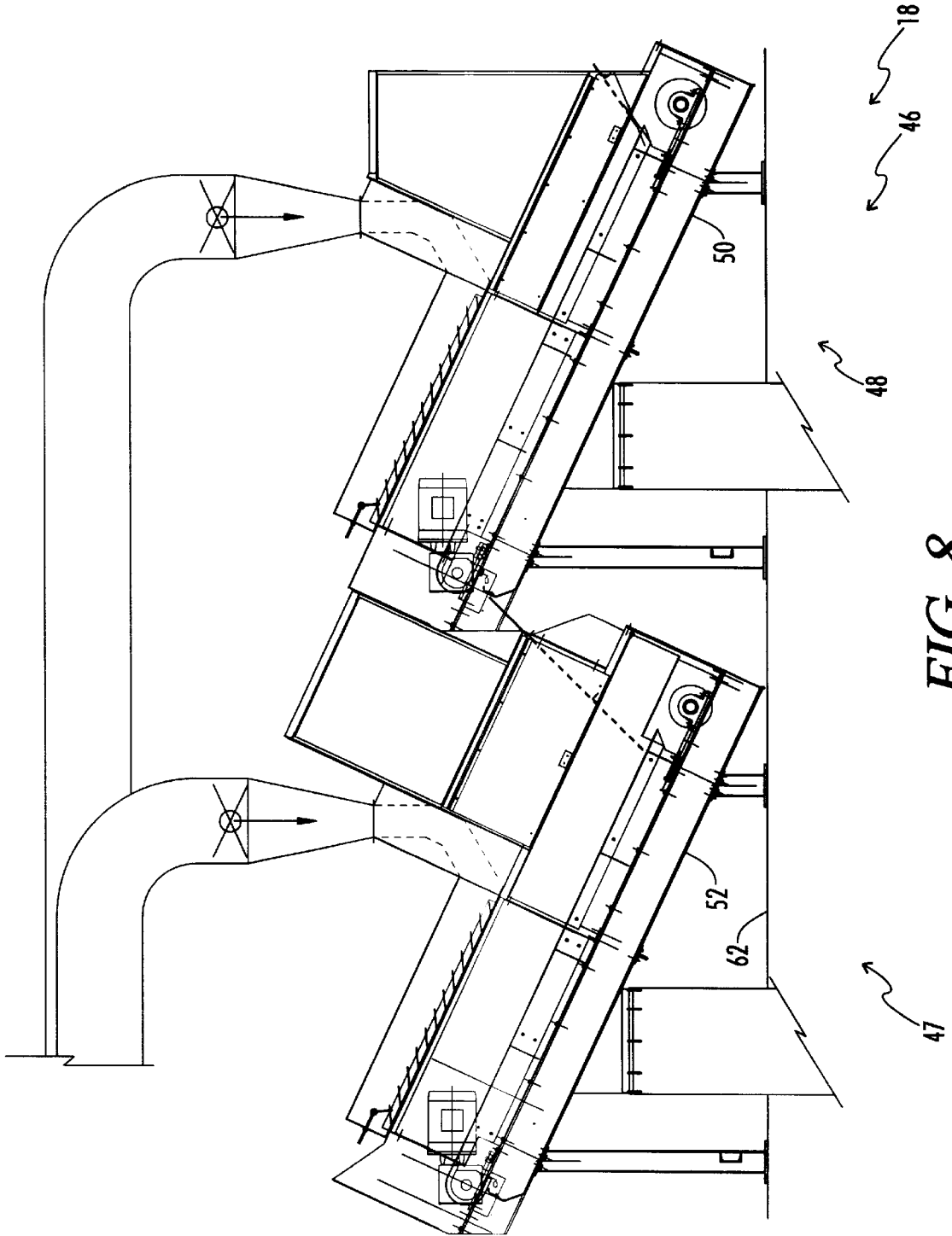
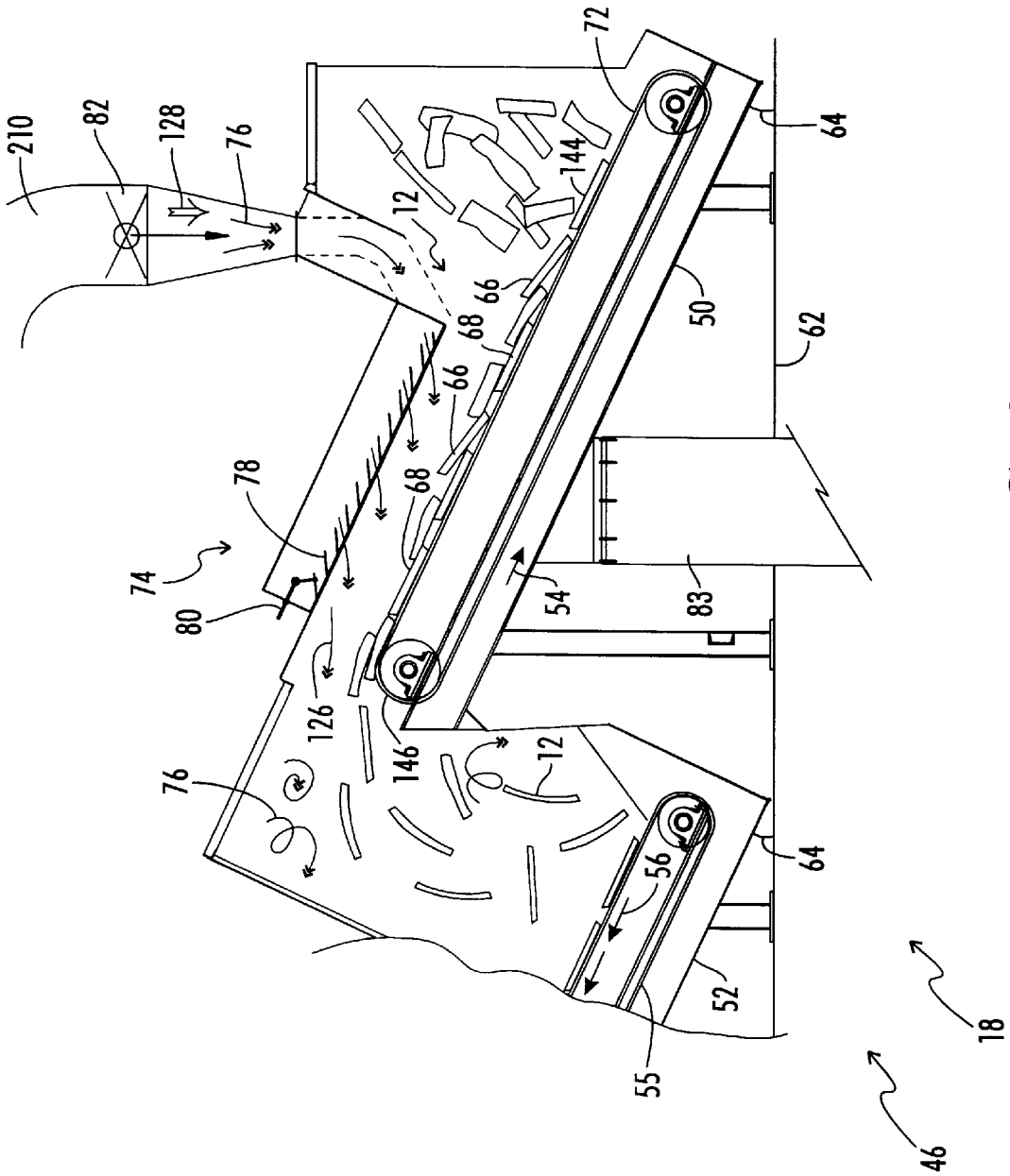

FIG. 8



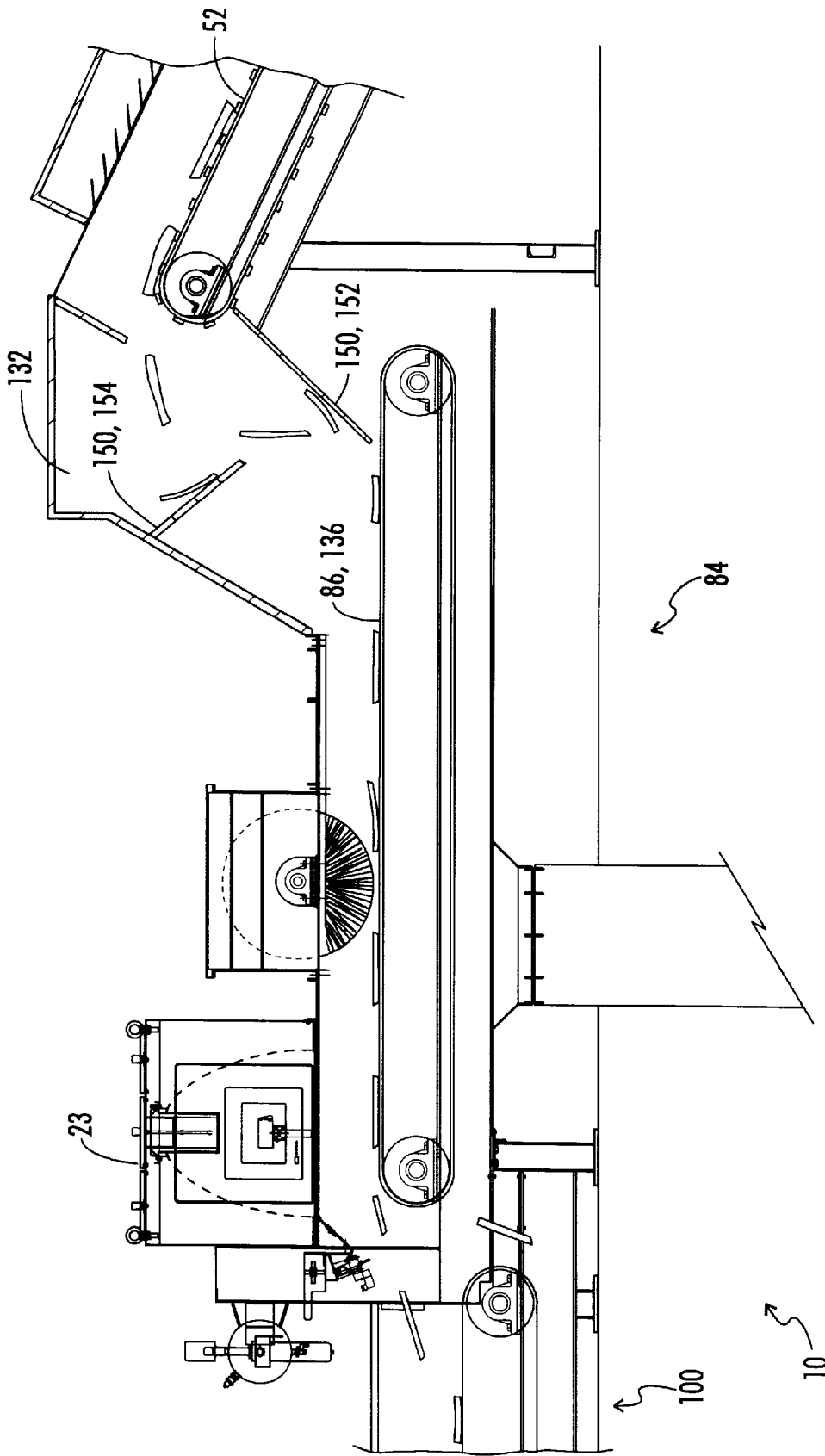
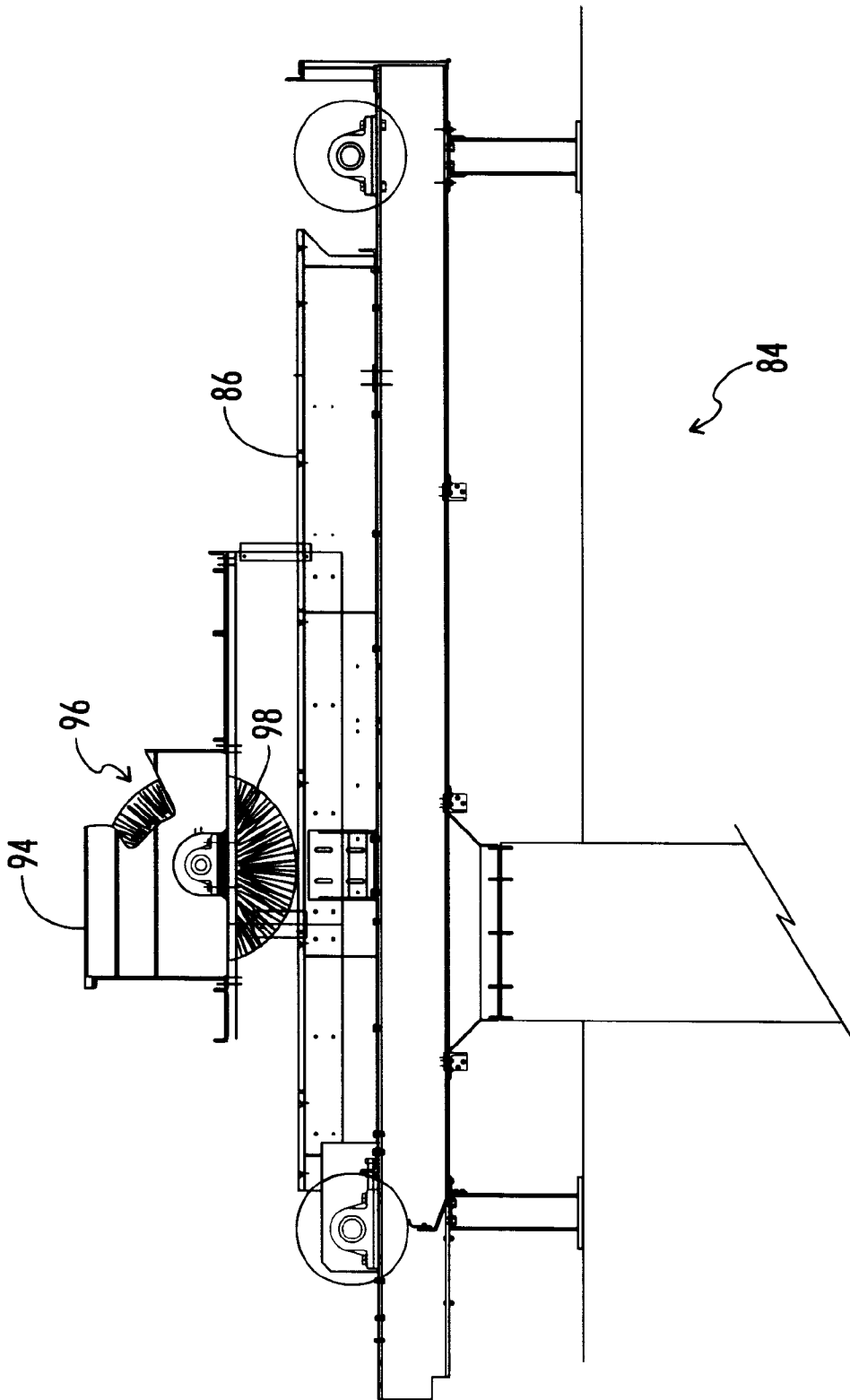

FIG. 10



**FIG. 11**

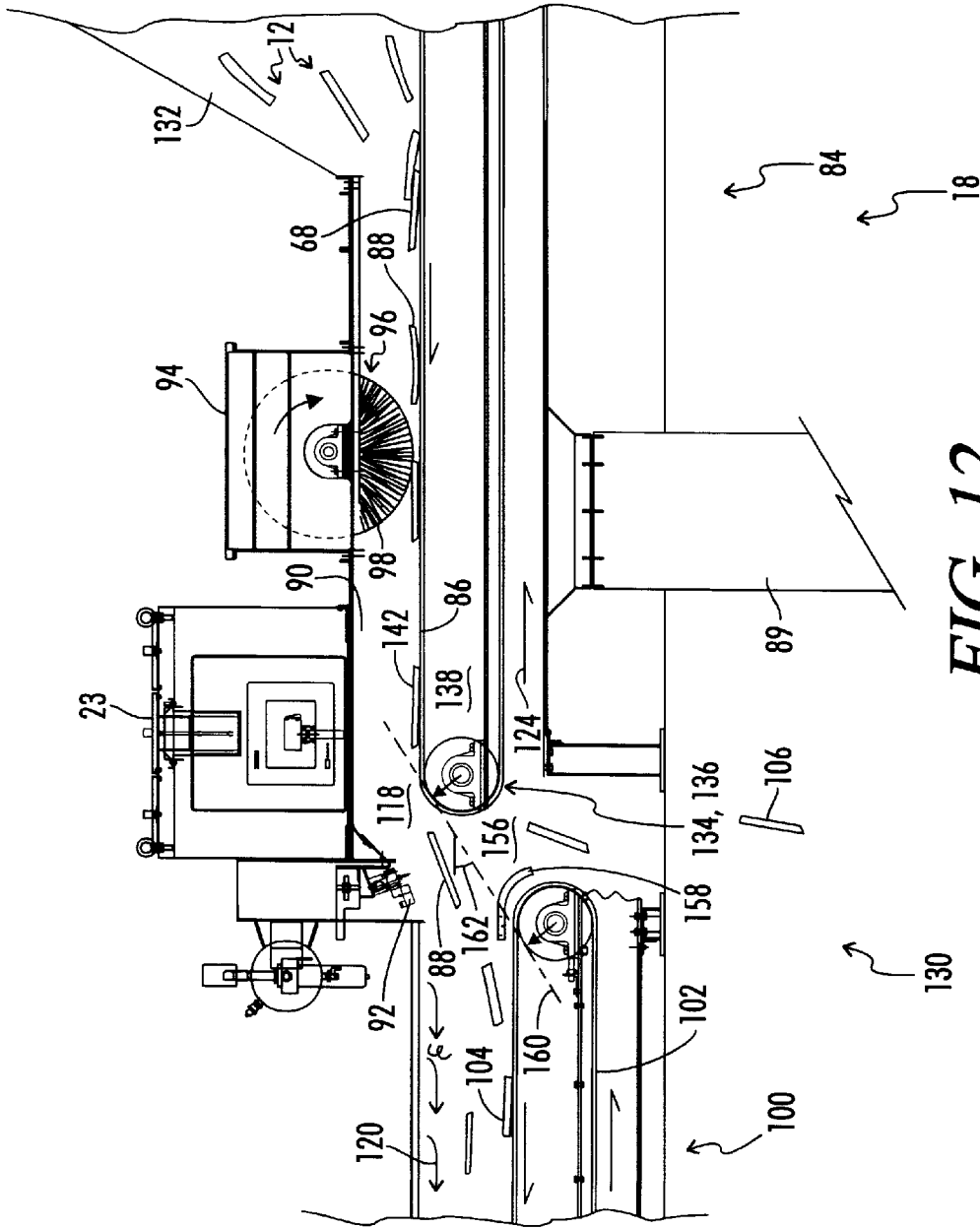

FIG. 12

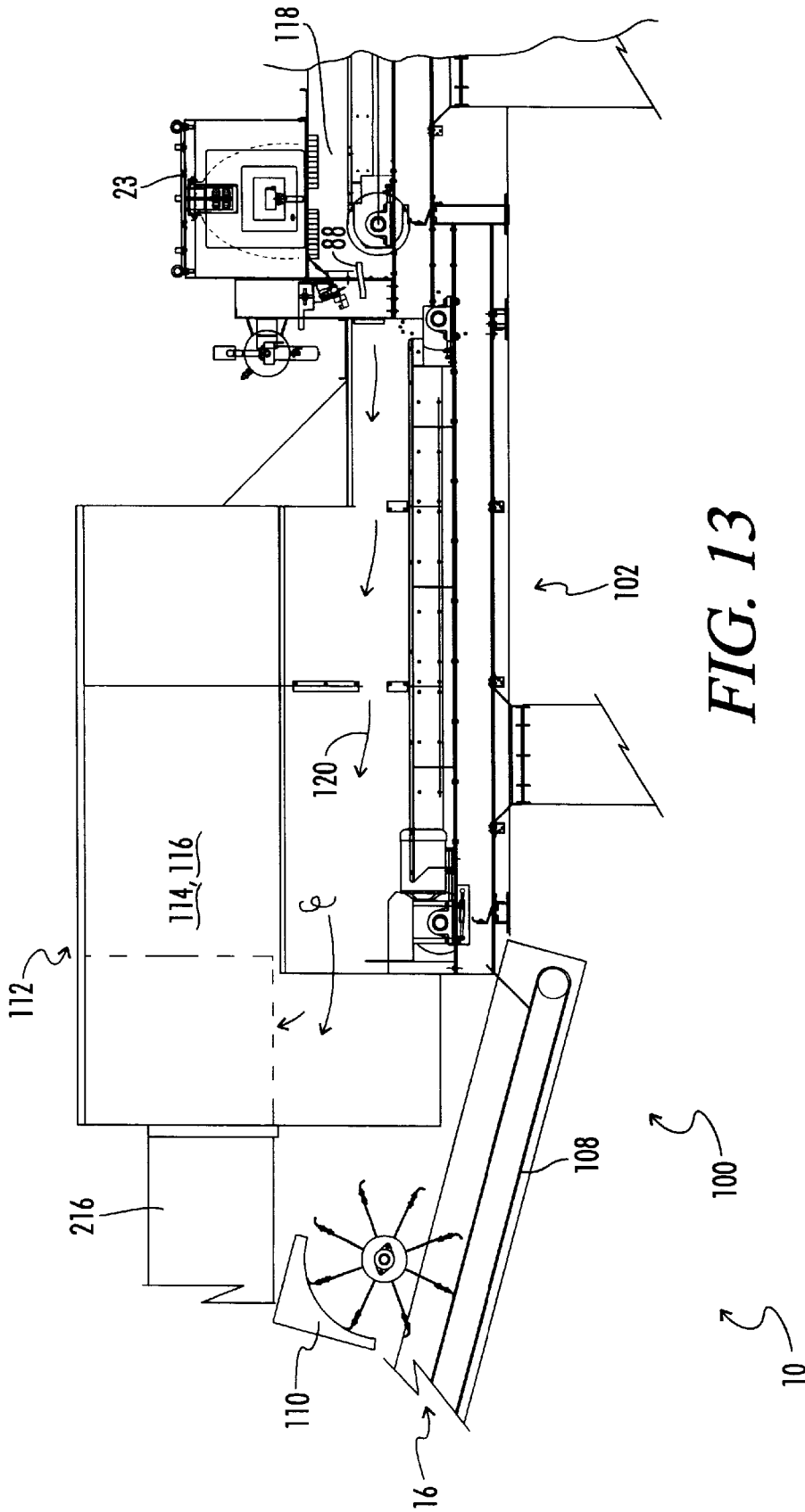

FIG. 13

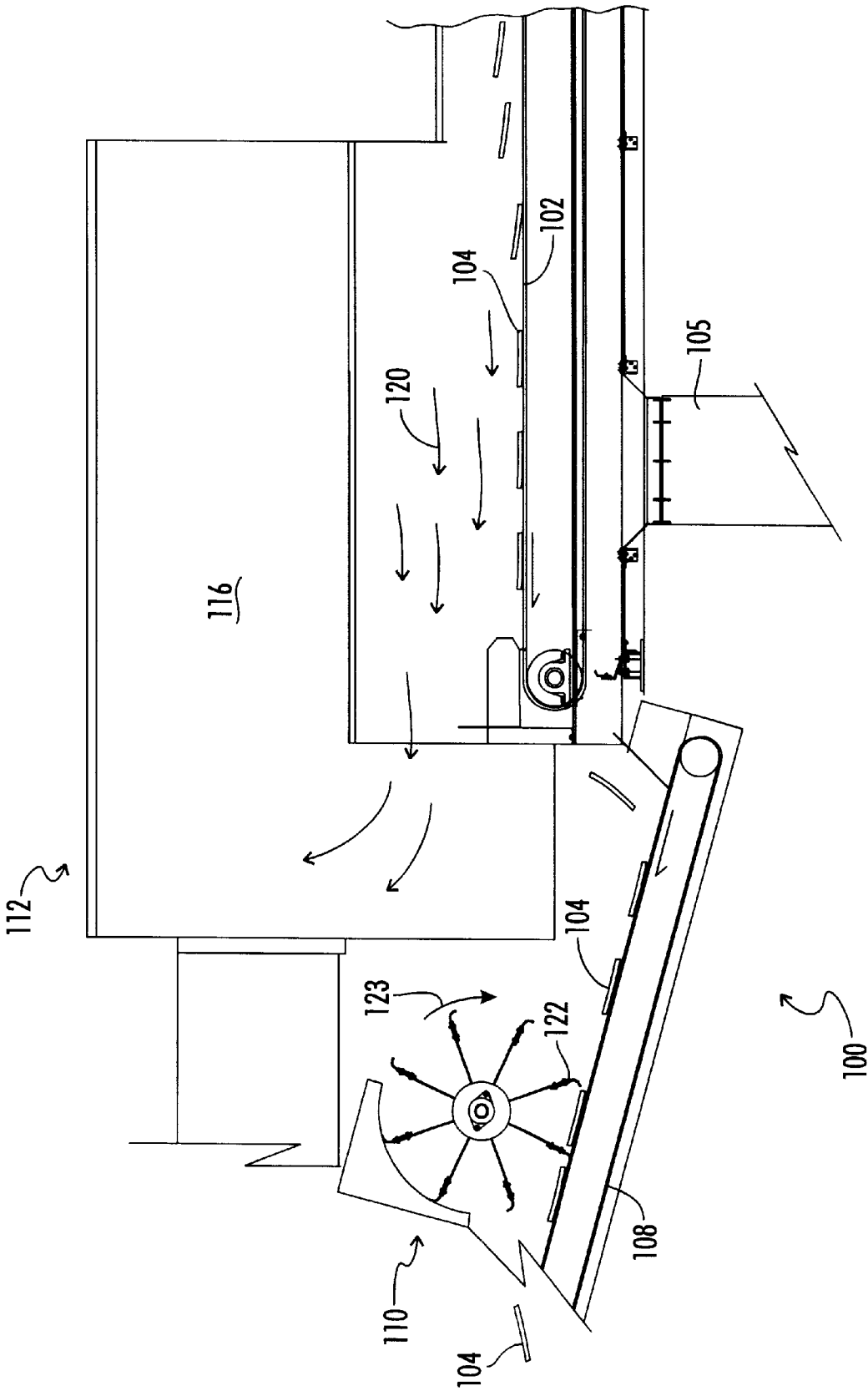

FIG. 14

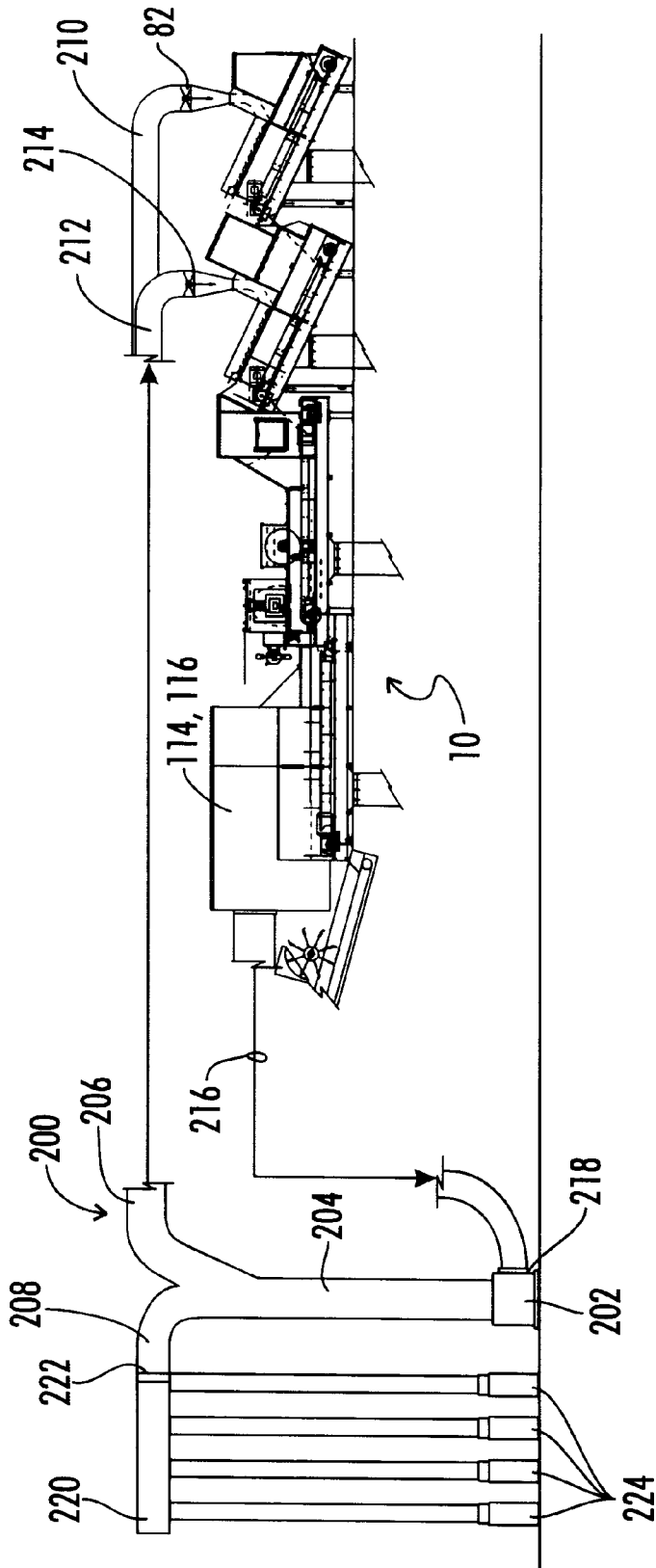

FIG. 15



1

**INCLINED CONVEYOR****BACKGROUND OF THE INVENTION**

The present invention relates to paper handling. Select embodiments of the invention are particularly well-suited for use in the waste paper recycling industry.

Environmental campaigns and recycling in many offices have generated a supply of recyclable waste paper. However, waste paper sorting is still currently performed almost entirely by manual sorting. This is time consuming and expensive. Thus, heretofore it has generally been more economical to use raw paper material than sort and process recyclable waste paper.

Numerous automated waste separation techniques are known. However these systems are designed for recovery of non-ferrous metals, aerospace alloys, municipal waste, mixed recyclables and plastic containers. Paper sorting presents unique problems not overcome by prior art separation techniques.

The unique problems encountered when attempting to sort waste paper is due to the relatively light weight and flexible nature of pieces of paper. These characteristics make it difficult to supply paper to a sorting sensor. Even when waste paper has been supplied to a sensor, it has not been supplied at a sufficient feed rate, e. g. pieces per hour (PPH), to be cost effective. Prior art sensors operate on the basis of an eddy current created by the waste stream as it passes through the sensor, diffusion of light transmission through the waste e. g. transparent glass, and the like. These techniques are inapplicable to sorting waste paper because the paper has no metallic components and the paper is opaque to light. Thus, not only must an effective paper sorting sensor be designed, an effective paper handling system must be designed to supply waste paper in sufficient feed rates to the effective paper sorting sensor. Prior art paper handling techniques have been unsatisfactory in overcoming these obstacles.

**SUMMARY OF THE INVENTION**

The present invention relates to paper handling and sorting methods and devices.

A paper handling system includes first and second inclined conveyors. The first inclined conveyor operates at a first speed and has an output end. The second inclined conveyor operates at a second speed and is operably positioned to receive paper output from the first inclined conveyor. The second speed is greater than the first speed. The inclined conveyors are preferably inclined at an angle in the range from 15° to 35°. By transporting the paper up the inclined conveyors, upper layers of paper are allowed to slide down over lower layers of paper thereby creating a thinner stream of paper.

Accordingly an object of the present invention is to provide means and methods for achieving a cost effective recycled machine grade paper fraction from a paper waste stream.

Another object of the present invention is to provide means for achieving automated sortation on a cost effective basis.

Another object of the present invention is to provide means for achieving improved consistency and repeatability in the quality of recycled waste paper.

Another object is to reduce labor requirements for sorting waste paper.

Another object of the present invention is to provide means and methods to accelerate and spread paper to operably thin layers to achieve an effective sort.

2

A further object of the present invention is to perform the sort at high speeds.

An object of the present invention is to incorporate automated sortation into a paper handling system to achieve consistent grades of premium paper from waste paper.

Other and further objects, features and advantages of the invention will be readily apparent to those skilled in the art upon a review of the following disclosure when taken in conjunction with the accompanying drawings.

**BRIEF DESCRIPTION OF THE DRAWINGS**

FIG. 1 shows a paper sorting system according to the present invention.

FIG. 2 depicts the system shown in FIG. 1 receiving clumps of paper, ejecting targeted paper, and delivering product.

FIG. 3 depicts an elevated side view the spreader included in FIG. 1. A paper input is shown on the right and discharge chutes depend from the spreader. FIG. 3 shows the spreader in its preferred inclined orientation.

FIG. 4 shows a simplified schematic plan view of the spreader shown in FIG. 3 with the paper input removed. A plurality of rotatable shafts including a plurality of discs on each shaft is depicted. The discs are oriented at zero degrees and forty-five degrees on alternating shafts.

FIG. 5 depicts an elevated side view of a rubber tipped disc. The disc is shown oriented at zero degrees.

FIG. 6 depicts a plan view of the spreader shown in FIG. 4 wherein three sets of the rotatable shafts are rotated at progressively increasing speeds. Clumps of paper are shown being fed and accelerated on the rotatable shafts.

FIG. 7 shows a somewhat schematic elevated side view of the spreader shown in FIG. 3. FIG. 7 shows the spreader in an optional non-inclined orientation. Clumps of paper are shown being fed into the product input and accelerated downstream. An end-on view of three sets of rotatable shafts, which are rotating at increasing speeds, is shown.

FIG. 8 shows an enlarged view of the two inclined conveyors included in FIG. 1. The first inclined conveyor is positioned to feed into the second inclined conveyor.

FIG. 9 shows a simplified enlarged view of the first inclined conveyor shown in FIG. 8. The first inclined conveyor is shown accelerating underlying layers of paper and feeding the paper to the second inclined conveyor. Air supplied through a set of louvers pins the paper to the inclined conveyor belt and fluffs, and further spreads, the paper as it cascades off of the end of the first inclined conveyor.

FIG. 10 depicts an enlarged view of the acceleration conveyor, sensor and product conveyor shown in FIG. 1.

FIG. 11 depicts the acceleration conveyor of FIG. 10 without the sensor and without the product conveyor.

FIG. 12 shows a schematic view of the structure shown in FIG. 10. Paper is shown pinned to the acceleration belt to feed the paper through the sensor at a predetermined speed substantially equal to the belt speed. Targeted paper is shown being ejected from the system and product paper is shown being conveyed away.

FIG. 13 shows an enlarged view of a product removal apparatus of the paper handler shown in FIG. 1. The product removal apparatus is shown downstream of the sensor and acceleration belt.

FIG. 14 depicts a schematic view of the product removal apparatus shown in FIG. 13. Paper is shown being pulled

through the product removal conveyor and pinned to the product conveyor by an air flow generated by an air-assist means. An airlock including a rotating seal is shown de-entraining product.

FIG. 15 schematically depicts the air flow system used with the paper sorting system of FIG. 1.

#### DESCRIPTION OF THE PREFERRED EMBODIMENTS

The present invention relates to methods and apparatus for handling, in particular sorting, paper. The invention will be best understood by reference to the attached drawings wherein like reference numerals refer to like components.

FIG. 1 shows an elevated side view of one embodiment of the present invention for a paper handling or sorting system 10. Referring to FIG. 2, the paper handling system 10 is adapted to handle paper 12 fed into the system. The system 10, in the embodiment shown in FIG. 2, comprises a paper input 14 adapted to receive the paper 12, and a product output 16. The system 10 includes acceleration means 18 for distributing and accelerating the paper 12. The acceleration means 18 is operably positioned between the paper input 14 and the product output 16. As is further explained below, the acceleration means 18 includes several separate components including spreader 26, inclined conveyors 50 and 52, and acceleration conveyor 84.

In some embodiments, the system 10 comprises an ejection output 20 between the paper input 14 and the product output 16. A sensor means 22 for determining whether paper should be routed to the ejection output 20 or the product output 16 is included in the system 10 shown in FIG. 2. Generally the acceleration means 18 accelerates the paper 12 from a first speed proximate the paper input 14 to a second higher speed proximate sensor means 22.

In some embodiments the paper 12 is fed from a pit conveyor (not shown) to the paper input 14 at a rate of ten to thirty feet per minute. This may be via a lift conveyor (not shown) which transfers mixed waste paper from the pit conveyor to the paper input 14.

In order to effectively eject sensed target paper, it is important that the paper 12 pass through the sensor means 22 at a predetermined speed. The sensor means 22 includes a sensor 23. In some embodiments the predetermined speed at which the paper 12 passes through the sensor 23 is 1000 or 1200 feet per minute. One goal is to accelerate the paper 12 from a first speed at which it enters the system 10 to a greater speed and pass it through the sensor at the greater speed. Thus, the paper may be accelerated from 10 ft./min. to 1200 ft./min.

Another goal is to spread and separate the paper in order to achieve a more effective and efficient sort. Thus, in one embodiment the acceleration means includes the spreading means or spreader 24 for distributing and spreading paper 12. The paper 12 generally enters the system in clumps at the paper input 14.

#### THE SPREADER

FIG. 3 shows an elevated side view of the spreader 24 shown in FIG. 2. FIG. 4 shows a simplified or schematic plan view of the spreader 24 shown in FIG. 3. In the embodiment of FIG. 3, the spreader 24 is shown in its preferred inclined orientation with the frame and thus the paper flow path being at an angle 25 which is in the range of 10° to 20°, and is preferably in the range of 14° to 16°. The spreader 24 includes a plurality of rotatable shafts 28. Each rotatable shaft 28 includes a plurality of discs 30.

FIG. 5 shows an elevated side view of a disc 30. In the embodiment shown in FIG. 5 the disc 30 is a bulged triangular disc which includes rubber tips or edges 32. Other effective disc configurations will be apparent to those with skill in the art. The rubber tip 32, which is urethane in one preferred embodiment, helps grip the paper 12 and accelerate paper 12 which is contacting the discs 30 ahead of other paper 12 not yet contacting the discs 30. Other disc friction enhancing embodiments will be apparent to those with skill in the art.

As noted, FIGS. 4, 6 and 7 are somewhat schematic illustrations of the arrangement of the disc 30. FIG. 7 illustrates an alternative orientation of spreader 24 in a non-inclined position. Although the spreader 24 will operate successfully in the non-inclined position of FIG. 7, it has been found to be preferable to incline spreader 24 as shown in FIG. 3. The inclination of the spreader aids in the separation and spreading of the paper, as it allows top layers to slide back over bottom layers.

In actual construction, the discs 30 are typically formed from one-quarter inch thick urethane sheet material. Adjacent discs are typically separated by a spacer plate (not shown) having a thickness on the order of one to two inches.

FIGS. 6 and 7 show plan and elevated side views, respectively, of the spreader 24 in which paper 12 is spread and accelerated by the rotatable shafts 28 and discs 30.

The plurality of rotatable shafts 28 comprise bulged triangular discs 30. The bulged triangular discs 30 are rotated 45 degrees relative to the remainder of the bulged triangular discs 30. As shown in FIG. 6 every other shaft includes a point of the disc 30 projecting out of the page. This is shown in FIG. 7 as well.

FIG. 6 shows paper 12 flowing downstream in the direction of arrows 31 from the paper input 14 toward the product output 16. Downstream is defined as the direction from the paper input 14 toward the product output 16. As shown in FIG. 6, the plurality of rotatable shafts 28 are generally transverse to the flow of paper 12.

The triangular shaped discs 30 function to vibrate and undulate the paper stream as it flows across discs 30. This is accomplished by the tips of the discs 30 impacting the paper stream at regular time intervals between impacts as the paper travels downstream.

FIG. 7 shows an elevated side view of the spreader 24. The plurality of shafts 28 comprises at least two sets of shafts including a first set of shafts 34 operating at a first speed 36. The first speed 36 is indicated by the rotation arrows shown in FIGS. 6 and 7. The plurality of shafts 28 also includes a second set of shafts 38 operating at a second speed 40. As shown in FIGS. 6 and 7, the second speed 40 is higher than the first speed 36. This is indicated by use of an increased number of rotation arrows for increased speeds. Also depicted in FIGS. 6 and 7 is a third set of shafts 42 operating at a third speed 44.

In one embodiment the first 34, the second 38, and the third 42 set of shafts rotate at progressively increasing speeds. In one embodiment the first set of rotatable shafts 34 rotates at a tip speed of approximately 155 feet per minute; the second set of rotatable shafts 38 rotate at a tip speed of approximately 280 feet per minute; and the third set of rotatable shafts 42 operate at a tip speed of approximately 386 feet per minute.

These progressively increasing speeds of the first, second and third sets of shafts are accomplished by a drive means 43 including a drive motor 47 driving a gear box 49 which in turn is drivingly connected to one of the shafts 28 (see

FIG. 3). The various shafts each carry two sprockets (not shown) on their outer ends, and the sprockets of adjacent shafts are connected by drive chains (not shown). The desired relative speeds of the various shafts are controlled by the selection of the size of the sprockets attached to each shaft. Thus if it is desired to double the speed of one shaft relative to the adjacent shaft, the two shafts carry sprockets one of which has twice the number of teeth as the other, the two sprockets being connected by a chain.

Undersized material will fall between the shafts 28 and discs 30. Removable canvas chutes 45 direct this undersized material to bins (not shown). Thus, the spreader 24 also functions as a trommel, or a sifter.

#### THE INCLINED CONVEYORS

Referring to FIG. 2 the acceleration means 18 includes a plurality of inclined conveyors 50 and 52 located downstream of the spreader 24.

FIG. 9 shows a schematic enlarged view of the inclined conveyors 50 and 52. In FIG. 9 the first inclined conveyor 50 operates at a first inclined conveyor speed 54. The second inclined conveyor 52 operates at a second inclined conveyor speed 56. Preferably the second inclined conveyor speed 56 is higher than the first inclined conveyor speed 54. The increase in speed from one conveyor to another facilitates spreading, thinning, and acceleration of the paper 12.

FIG. 7 shows an embodiment wherein the spreader 24 comprises a spreader output 58. Proximate to the spreader output 58, the spreader 24 operates at an output speed 60. Preferably the first inclined conveyor speed 54 is higher than the spreader output speed 60. The speed at which the paper travels downstream is thus progressively increased.

Typically the first and second inclined conveyors 50 and 52 are inclined, relative to a horizontal floor 62, at an angle 64 in the range of ten degrees to thirty-five degrees (10° to 35°). The incline of the conveyors provides means for top layers of paper 66 to slide off of bottom layers of paper 68. This further spreads the paper into thinner layers. Preferably the inclination angle 64 of first and second inclined conveyors 50 and 52 is about twenty-five degrees (25°).

Preferably the conveyor 50 comprises a belt 70 including rough top material 72. In some embodiments, the conveyor belting is vulcanized seamless rough top rubber material. The rough top material 72 helps grip the bottom layers of paper 68 and accelerate them to a speed substantially equivalent to the speed of the inclined conveyor belt. The material further helps to spread the bottom layers of paper 68 apart from the top layers of paper 66. The bottom layers of paper 68 are being pulled or carried along the belt 70 at a greater speed than the top layers of paper 66, while the top layers of paper 66 slide down off of the bottom layers of paper 68 due to gravity. Other conventional belting material to effectuate objectives of the present invention win be apparent to those of skill.

In some embodiments the inclined conveyor 50 comprises a belt 70 and assist means 74. The assist means 74 is for pinning the paper 12 to the belt 70. In the embodiment shown in FIG. 9, air 76 flows through a set of louvers 78 positioned above the belt 70. The air flows downward against paper 68 to assist in pinning paper 68 to belt 70. The louvers 78 may be adjusted, opened, closed, or oriented, by a louver handle 80. They may be automatically adjusted as well as manually adjusted. The air 76 is controlled through an air knife 82.

Also the air assist means 74 provides a means for fluffing the paper as it cascades off the first inclined conveyor 50 onto the second inclined conveyor 52.

Any paper which adheres to of conveyor 50 and carries over the discharge end thereof will be directed to canvas chute 83 which transfers material from a drop-out opening to container on the floor. It is noted that each of the conveyors described herein has close fitting sidewalls enclosing it on each side, so that paper cannot fall off the side of the conveyor.

In some embodiments the inclined conveyors will have variable frequency drives.

Provisions may be made for a portion of sidewalls of a conveyor to be removable for replacement of the belting. Access ports for cleaning out jams that might occur at transfer points between conveyors may be incorporated. Viewing windows may be provided to allow material flow to be observed during operations.

In some embodiments a uniform, metered feed stream of waste paper will be accepted from a typical input feed system. Multiple stages of high-speed rough-top inclined conveyors may be positioned in series to accelerate and distribute the in feed waste paper as it is being transported to an automated sensing/ejection system.

It is important to note that components of the paper handling system need not be aligned in a straight line as shown in FIG. 2. It will be apparent to those with skill in the art that bends and angles may be incorporated where appropriate. Intermediate transport or delivery conveyors may be incorporated where appropriate as well.

#### THE ACCELERATION CONVEYOR AND PRODUCT CONVEYOR

The system 10 shown in FIG. 2 comprises an acceleration conveyor 84, which may also be referred to as a feed means 84 for feeding the paper 12 at a predetermined speed to the sensor means 22, 23. The acceleration conveyor 84 is positioned downstream of the inclined conveyors 50 and 52. FIG. 10 shows an enlarged elevated side view of the feed means 84. In one embodiment the second conveyor 52 operates at an inclined conveyor speed which is slower than the predetermined speed at which the paper 12 is fed to the sensor 22, 23.

FIG. 11 shows an embodiment in which the acceleration conveyor 84 comprises an acceleration belt 86. Referring to FIG. 12, the acceleration belt 86 accelerates the paper 88 to a predetermined speed at which it passes through the sensor 23. The sensor 23 shown in FIG. 12 comprises a light source 90 under which the paper 88 passes. Downstream of the sensor 23 is an ejector 92. Preferably the paper 88 passes through the sensor 23 at the predetermined speed so that the ejector 92 may be operated to eject the selected paper. The velocity at which the paper travels and the distance to the sensor determines when the ejector must emit a burst of air to remove the target paper from the waste stream. In one preferred embodiment the ejector 92 includes a plurality of high compression air jets.

Any paper which adheres to the acceleration belt 86 and carries over the discharge end thereof will be directed to a canvas chute 89 which transfers that material to a waste container (not shown).

The system 10 includes a mechanical pinning means 94 for pinning the paper 88 to the acceleration belt 86. The pinning means 94 is a rotary feeder 96 positioned above and contacting the acceleration belt 86. In some preferred embodiments, the acceleration belt 86 comprises standard PVC material. In some preferred embodiments the rotary feeder 96 is flexible and in contact with the acceleration belt 86. In one embodiment the rotary feeder 96 includes a plurality of flexible bristles 98 extending radially.

FIG. 2 shows a product removal apparatus **100** downstream of the sensor **23**. The ejector **92**, shown more clearly in FIG. 12, is positioned between the sensor **23** and the product removal apparatus **100**.

The product removal apparatus **100** shown in FIG. 12 comprises a product conveyor **102** below and downstream of the acceleration belt **86**. Product **104** is carried downstream by the product conveyor **102**. The product conveyor **102** will take non-targeted paper (also referred to as product **104**) away from the sensing area **118**. In some embodiments it will operate at a fixed speed of approximately 600 feet per minute. The conveyor belting may be vulcanized seamless rubber.

Ejected paper **106** (also referred to as targeted paper **106**) is ejected by the ejector **92**. Preferably the amount of material selected for ejection is smaller than the amount of product going to product conveyor **102**. The precision air-jet ejection system may be mounted on the infeed of the product take-away conveyor (also referred to as product conveyor **102**). The ejector **92** uses signals received from the sensor **23** to selectively eject targeted materials using an array of high-pressure compressed air nozzles.

Any paper adheres to product conveyor **102** and carries over the discharge end thereof is directed through a drop-out opening to a canvas chute **105** to transfer the waste paper material to a container on the floor.

FIG. 13 shows an enlarged view of the product removal apparatus **100** shown in FIG. 2. The product removal apparatus **100** shown in FIG. 13 includes a sort conveyor **108** and an airlock **110**. The sort conveyor **108** will take the paper fraction that passes through the system without being ejected and deliver it to a baler (not shown). The sort conveyor **108** will be operated in some embodiments at a fixed speed of 100 feet per minute. The sort conveyor **108** includes the product output **16** and the airlock **110**. The airlock **110** is proximate the product output **16**. The airlock **110** is used to de-entrain paper, or product, **104**. The airlock **110** acts as an air seal on the sort conveyor **108** to allow paper **104** to exit while restricting the discharge of air. Rotating tips **122** have a tip speed **123**. The tip speed **123** may be fixed, in some embodiments, to match the speed of the sort conveyor **108**. In some embodiments the tip speed **123** is 100 ft./min.; and the sort conveyor **108** operates at 100 ft./min. In some applications the airlock **110** may be replaced by a system of rubber flaps.

The acceleration conveyor **84** may also be described as a paper handler **130** (an embodiment of which is shown in FIG. 12) adapted for use with a sorting machine including a sensor **23** for sorting paper. In the embodiment shown in FIG. 12 the handler **130** comprises a paper input **132** for receiving the paper **12**. A product output (not shown in FIG. 12) is downstream of the paper input **132**. The paper handler **130** also includes a feed accelerator **134** including an acceleration conveyor **136** operably positioned to feed paper **12** (also shown as paper **88**) through the sensor **23**.

The paper handler **130** may further comprise the plurality of inclined conveyors **50** and **52** positioned upstream of the acceleration conveyor **136**, as shown in FIG. 2. In one embodiment of the paper handler **130**, the first inclined conveyor **50** includes a belt substantially similar to the belt **70** shown in FIG. 9, operating at a first inclined conveyor speed **54**. The paper handler **130** also includes a second inclined conveyor **52** including a belt **55** operating at a second inclined conveyor speed **56**. In one preferred embodiment the second inclined conveyor speed **56** is greater than the first inclined conveyor speed **54**. The

accelerator conveyor **136** operates at an accelerator conveyor speed **124** (also referred to herein as acceleration belt speed) greater than the second inclined conveyor speed **56**.

In one preferred embodiment the first inclined conveyor speed is approximately four hundred fifty feet per minute (450 ft./min.); the second inclined conveyor speed is approximately seven hundred fifty feet per minute (750 ft./min.); and the accelerator conveyor speed is approximately twelve hundred feet per minute (1200 ft./min.).

In the embodiment of the paper handler **130** shown in FIG. 2 the first inclined conveyor **50** is operably positioned to receive paper **12** from the spreader **26** which in turn is operably positioned to receive paper **12** from the paper input **14**.

Referring to FIGS. 2 and 6, one embodiment of the paper handler **130** comprises rotatable shafts **28** positioned transversely relative to a stream of paper in the spreader **26**. The rotatable shafts **42** closer to the first inclined conveyor **50** rotate faster than the rotatable shafts **34** closer to the paper input **14**. In FIGS. 3 and 6, the paper input **14** and the first inclined conveyor **50** are not shown. However, the product input **14** would be nearer to the first set of shafts **34**, and the first inclined conveyor **50** would be located closer to the third set of rotatable shafts **42**.

In some embodiments the acceleration conveyor **136** will include a high-speed belt (operating at approximately 1200 ft./min.) to deliver a thin layer of mixed paper beneath the paper-sort sensor (also referred to herein simply as sensor). The conveyor will have a variable frequency drive and preferably vulcanized seamless belting. Provisions may be incorporated into the design of the belt to minimize carry-over of paper, and ease access for removal of materials which become entrapped. A drop-out chute may be incorporated into the under pan beneath the acceleration conveyor **136** to allow materials which enter beneath the belting to drop free without being moved to the tail section of the conveyor. A small rotary brush may be positioned at the discharge end of the conveyor (proximate air sensor end **138**) to assist with discharge of paper. It may be driven from a head-pulley of the acceleration conveyor. A large rotary brush **98** may be mounted on the acceleration conveyor to "pin" paper to the belt prior to entering the sensor area (**118**). The rotary brush **98** may have a fixed tip speed of approximately 800 feet per minute.

It is desirable to avoid unwanted disturbances to the paper flow by avoiding large speed differentials between the acceleration belt **86**, **136** and rotating pinning device **96**. This can be accomplished by rotating the pinning device so that the tips of its flexible bristles **98** have a tip speed approximately two-thirds of the speed at which the acceleration belt **86**, **136** operates.

The flexible bristles **98** further reduce damage to the rotatable pinning apparatus **96** if bulky materials are carried through by the acceleration belt **86**, **136**. The flexible bristles **98** can flex to allow the bulky materials to pass.

As previously noted, the speed of the acceleration belt **86** adjacent the sensor **22** may be as high as approximately twelve hundred feet per minute. Such a high speed of the acceleration belt **86** is sufficient to create a suction phenomena such that once paper such as **88** is pinned to the belt **86**, such as by means of the rotary pinning device **96**, the suction phenomena serves to further pin the paper to the belt so that the paper moves at substantially the same speed as the acceleration belt **86**.

As best seen in FIG. 10, at the input end **132** of the paper handler **130** there is located a catching structure **150** includ-

ing a downwardly inclined catching plate **152** to facilitate delivery of paper to the acceleration belt **86**, **136**. Paper slides off of catching plate **152** onto acceleration belt **86**, **136**. The catching structure **150** further includes a plurality of rods such as **154** projecting downwardly in a general direction toward the catching plate **152** and the acceleration belt **86**, **136**.

Thus, as seen in FIG. **10**, paper which is cascading off the end of the second inclined conveyor **52** is directed by rods **154** and catching plate **152** onto the upper surface of the acceleration conveyor **86**, **136**.

The paper impacts the plurality of rods **154** thus allowing the paper to separate as it falls onto the catching plate **152** and the conveyor belt **86**, **136**.

As best seen in FIG. **12**, when the paper **88** reaches the left hand end or output end of acceleration conveyor **86** after it has passed under the sensor **23**, it passes through a transition zone **156**. As the paper passes through the transition zone **156** it is still moving at substantially the same speed at which it was travelling on the acceleration conveyor **86**, **136**. This continued motion is in part assisted by the air flow through the system.

As the paper passes through the transition zone **156**, if it has been targeted by the sensor for ejection, a rapid burst of air from ejector **92** will blow the paper downward causing it to become targeted or ejected paper **106**. If the paper crossing through transition zone **156** is not impacted by air jets from ejector **92**, it will continue to flow generally horizontally and fall downward upon the product conveyor **102**.

The transition zone **156** which communicates the acceleration conveyor **86**, **136** with the product conveyor **132** can be described as including a separation region adjacent the acceleration conveyor **86**, **136** at which the paper separates from the acceleration conveyor **86**, **136**. The transition zone **156** may also be described as including a reception region adjacent and immediately above the transition plate **158** of product conveyor **102** wherein the product conveyor **102** receives a majority of the paper crossing through the transition zone **156**.

The transition zone **156** may also be described with reference to an imaginary transition plane **160** seen in FIG. **12** which extends from the top of the acceleration conveyor **86**, **136** and extends to that portion of the product conveyor **102** wherein the top surface thereof becomes generally horizontal and upon which the product paper will fall downstream of the transition plate **158**.

The transition plane **160** may be described as lying at an angle **162** relative to the horizontal, where the angle **162** lies in the range of from  $15^{\circ}$  to  $60^{\circ}$ . The transition angle **162** is preferably approximately  $30^{\circ}$ .

#### THE SENSOR AND EJECTOR SYSTEM

The sensor **23** is preferably a linear array of sensors spread across the width of the acceleration belt **86** in a direction normal to the plane of FIG. **12**. For example, for a forty-eight inch wide acceleration belt **86**, an array of approximately thirty-two sensors spaced across the width of the acceleration belt would be utilized.

The ejector **92** also comprises a linear array of ejectors spaced across the width of the transition zone **156** between acceleration belt **86** and product conveyor **102**.

In general the sensors **23** operate to identify bright white paper by searching for fluorescing additives in the individual sheets of paper. This type of paper has a higher value of fluorescence than paper without the additives.

The sensors illuminate the paper with a constant light source having a wave length of 360 nanometers. An elliptical mirror is used to focus light onto a region above the conveyor belt at approximately ten inches from the optic system. When paper with the fluorescing additives is illuminated with the light source, light is re-radiated in the 400 to 550 nanometer range. The sensor has a second light source that emits light in the 480 nanometer range. This light source is used to determine if any type of paper is present on the conveyor belt. It is turned on momentarily every three milliseconds and a reflected light measurement is made to determine if paper is present on the conveyor belt.

The details of construction of the sensor **23** are set forth in U.S. patent application, Ser. No. 09/301,715, of Bruner et al. filed concurrently herewith, entitled "SYSTEM AND METHOD FOR SENSING WHITE PAPER", and assigned to the Assignee of the present invention, the details of which are incorporated herein by reference.

The sensor system **23** will sense whether there is a piece of white paper on the belt **86**, and it will sense the location of that paper upon the belt. Since the paper is moving at a predetermined fixed speed, the time at which the paper passes through the transition zone **156** can be calculated by the computer associated with sensor **23**. This computerized control system will in turn actuate the appropriate number of the array of jets **92** at the appropriate time so as to blow any reject paper downward through the transition zone **156**.

#### THE AIR CIRCULATION SYSTEM

FIG. **15** shows an overall schematic view of an air circulation system **200** of the paper handling system **10**. Details of the air circulation system **200** are seen in FIGS. **13**, **15**, **2** and **9**.

With reference to FIG. **15**, it can be seen that air is circulated through the system **200** by a blower **202**. Pressurized air from blower **202** enters a discharge duct **204** which splits into a supply duct **206** and a filter duct **208**.

The supply duct **206** splits into first and second supply duct arms **210** and **212** which are directed to the housings immediately above the first and second inclined conveyor belts **50** and **52**.

Air knives **82** and **214** are disposed in the first and second supply duct arms **210** and **212**, respectively, adjacent their inlets to the housings surrounding the first and second inclined conveyors **50** and **52**, in order to control the flow of air into the housings adjacent the conveyors, and particularly to their louvers such as the louvers **78** associated with first inclined conveyor **50**. The first and second supply duct arms **210** and **212** may also include iris-type flow controls adjacent the air knives **82** and **214**.

It will be appreciated from the views previously described of the several components, that the inclined conveyors **50** and **52**, the acceleration conveyor **84**, and the product conveyor **102** all have associated therewith substantially enclosed housings so that the air which is provided through air supply duct arms **210** and **212** to the housings adjacent inclined conveyors **50** and **52** is directed through the housings of conveyors **50** and **52**, then through the housings surrounding acceleration conveyor **84** then through the sensing area **118** across the product conveyor **102**.

A portion of this air circulation system can be described as an air assist means **112** which is part of the product removal apparatus **100** and which assists in maintaining the predetermined speed of the paper **88** through the sensor **23**. In one preferred embodiment the air assist means **112** includes a vacuum **114**, which may also be described as a

low pressure area **114**, downstream of the sensor **23** as is illustrated in FIG. **13**.

The vacuum or low pressure area **114** forms within a plenum chamber **116** defined adjacent the left hand end of product conveyor **102** in FIG. **13**.

An air recycle duct **216** is connected to the suction inlet **218** of blower **202** in order to pull air from the plenum chamber **116** thus creating the low pressure zone **114** therein. A screen may be utilized adjacent return duct **216** to prevent carry over of paper to the blower **202**.

The filter duct **208** leads to a plenum **220** and air flow thereto can be controlled by a motorized damper **222**. Plenum **220** is connected to a plurality of filter bags **224**. The filter bags **224** are used to remove dust from the air system prior to releasing it to the atmosphere.

In one embodiment, the blower **202** is a 6000 CFM blower, which is a variable speed blower for controlling the speed of the air drawn through the sensor area **118**. In a typical system, 2000 CFM would be directed to the filter duct **208**, with 4000 CFM flowing through supply duct **206** which in turn splits into two streams of 2000 CFM each in supply duct arms **210** and **212** which are directed to the inclined conveyors **50** and **52**.

It is noted that in FIG. **12** the area between the product conveyor **102** and the acceleration belt **86** is shown open at the bottom for clarity. In practice this area will be closed in order to facilitate control of air flow through the system.

The air circulating through the system illustrated in FIG. **15** provides several functions.

When the air first flows in through the louvers such as **78** of the first and second inclined conveyors **50** and **52**, that air flow functions to help pin the paper onto the inclined conveyors so as to help accelerate the paper speed up to the conveyor speed.

The air also aids in fluffing the paper as it cascades off the ends of the inclined conveyors.

The air also assists in the downstream movement of the paper through the system.

Particularly, the air assists in the movement of the paper through the sensing area **118** across the gap between acceleration belt **86** and product belt **102**.

The plenum chamber **116** adjacent the downstream end of the product conveyor **102** may be utilized to reduce the air flow to a speed below two hundred feet per minute in order to allow the paper to settle out on the product conveyor **102**.

The housing which defines the plenum **116** has a much larger area at plenum **116** than it does upstream near the transition zone **156**, so that the air speed is much higher near the transition zone **156** than it is downstream adjacent the plenum **116**.

The right hand end of the product conveyor **102** may generally be described as a transition end thereof. A transition plate **158** is located immediately above the transition end of the product conveyor **102**. The transition plate **158** is curved to conform to the general shape of the curved end of the product conveyor **102**, and functions to prevent paper from falling back off the transition end of the product conveyor.

## METHODS

The present invention also includes various methods for handling paper. One method comprises the steps of distributing clumps of paper **140** (see FIG. **2**) into operably thin layers of paper **142** (see FIG. **12**). Operably thin is defined

to be thin enough to accomplish the goal for which the paper is being handled. In one preferred embodiment the goal is to sense the paper by passing it through a sensor. To accomplish this goal the paper should be thin enough that the sensor may adequately sense and distinguish pieces of paper. The paper may then be sorted by an ejector. The method of handling paper also comprises accelerating the paper. The step of accelerating the paper includes progressively increasing the speed at which the paper is transported downstream.

One embodiment of this method comprises the steps of breaking up clumps of paper **42** in a spreader **26**. An apparatus for accomplishing this is shown in FIG. **6**. The method may also comprise rotating rotatable shafts **28** in the spreader **26** to progressively increase the speed at which the paper travels. The paper is also generally referred to herein by designation **12**. Another method of the invention comprises the step of feeding the paper **12** into a plurality of inclined conveyors **50** and **52**. This is shown in FIGS. **2** and **9**. The respective plurality of inclined conveyor belts catch underlying layers of paper **68**. The underlying layers of paper **68** are also referred to as bottom layers of paper **68**. The method includes accelerating the underlying layers of paper **68** up to speeds approximating speeds at which the respective plurality of inclined conveyor belts operate.

One preferred embodiment of the invention comprises the step of inclining the inclined conveyors between fifteen degrees and thirty-five degrees ( $15^{\circ}$ – $35^{\circ}$ ). This is the optimal range for paper to adhere to and travel up the conveyor while paper on the top slides off the bottom paper due to gravity. Generally, layers of paper will begin to slide over lower layers of paper due to gravity at an incline of  $15^{\circ}$ . Beyond  $35^{\circ}$  the paper will not adhere to the belt as easily. This takes advantage of paper's friction co-efficient. The method includes allowing paper **66** above the underlying layers **68** to slide down the incline and become new underlying layers. A new underlying layer **144** is shown in FIG. **9**. The method then includes catching the new underlying layers **144** with the respective plurality of inclined conveyor belts and accelerating the new underlying layers **144** of paper **12** up to speeds approximating the speeds at which the respective plurality of inclined conveyor belts operate.

In some embodiments the method comprises the step of pinning the underlying layers of paper **68** to the respective plurality of inclined belts with air **76** and **126**. This is shown in FIG. **9** in which air-assist means **74** pins and fluffs the paper **12**. Accordingly, one method comprises the step of fluffing the paper **12** as it cascades off respective ends of the respective plurality of inclined conveyors. In FIG. **9** one respective end is designated **146** on inclined conveyor **50**.

It is desirable to adjust volumes of air flow **76** with air knives **82** and direct air **76** (also shown as direction of air **126**) with respective sets of louvers **78** in the inclined conveyors **50** and **52**.

Preferably inclined conveyors downstream are operated at higher speeds than inclined conveyors upstream. Referring to FIGS. **2** and **12**, it will be apparent that the present invention also includes the method of catching underlying layers of paper **68** on an acceleration belt **86**. The underlying paper **68** is accelerated to a predetermined speed. The paper (referred to in FIG. **12** by designation number **88**) is allowed to pass through a sensor **23** at the predetermined speed.

In one preferred embodiment a rotary feeder **96** is rotated above the acceleration belt **86** to pin the paper **88** to the acceleration belt **86**. The method also includes contacting the paper **88** and pinning the paper **88** to the acceleration belt **86** as the paper **88** passes between the acceleration belt **86**

13

and the rotary feeder **96**. Preferably damage to the rotary feeder **96** is prevented by allowing the rotary feeder **96** to flex. In some embodiments the rotary feeder operates at a speed less than the acceleration belt **86**. In one embodiment the rotary feeder rotates at speeds of eight hundred feet per minute (800 ft./min.) and the acceleration belt operates at speeds approximating twelve hundred feet per minute (1200 ft./min.). More generally, a preferred embodiment in the present invention includes the step of rotating the rotary feeder **96** at approximately two-thirds of the speed at which the acceleration belt **86** operates. This prevents the pinning device from being bent up by a large speed differential when the pinning device contacts the high velocity acceleration belt **86**. This also reduces the likelihood that the paper **88** will be turned up at its end as it is caught between a stationary pinning device and a high velocity belt.

Another method of the present invention comprises the steps of allowing the paper **88** to pass through a sensor **23** and ejecting paper **106** (also referred to as targeted paper) selected for ejection (See FIG. 12). The method also includes allowing non-selected paper, also referred to herein as product, **104** to continue downstream to a product conveyor **102**. Preferably the predetermined speed of the paper **88** is maintained through the sensor **23** with air-assistance **112** (not shown in FIG. 12).

Another embodiment of handling paper comprises drawing the paper **88** with a vacuum **114** downstream of the ejector **92**, and matching a vacuum speed at which the vacuum **112** draws to a belt speed at which the acceleration belt **86** operates. The acceleration belt **86** accelerates paper **88** through the sensor **23** at a sensor speed (not shown) substantially equal to the acceleration belt speed **124** at which the acceleration belt **86** operates. Sensor speed as used here refers to the rate at which the sensor may sense material passing through it.

In some embodiments the method comprises the steps of adhering the paper **104** to the product conveyor belt **102** with the vacuum **114**.

Other methods of the invention comprise spreading and accelerating the paper in a spreader **26**, and transporting and accelerating the paper **12** up a first inclined conveyor **50**. The paper **12** is accelerated with the first inclined conveyor. The method also includes transporting and accelerating the paper **12** up a second inclined conveyor **52** and then accelerating the paper through a sensor **23** at a predetermined feed. In some embodiments the paper is pinned with a rotary feeder **96** proximate the sensor **23**. It is desirable in some embodi-

14

ments to maintain paper flow through the sensor **23** with a vacuum **114**. The method also comprises ejecting selected paper **106**.

Thus, although there have been described particular embodiments of the present invention of a new and useful INCLINED CONVEYOR, it is not intended that such references be construed as limitations upon the scope of this invention except as set forth in the following claims.

What is claimed is:

1. A method of handling paper comprising the steps of: supplying paper to a first inclined conveyor; carrying the paper up the first inclined conveyor; feeding the paper output from the first inclined conveyor to a second inclined conveyor; carrying the paper up the second inclined conveyor; spreading the paper; and adjusting volumes of air flow to facilitate spreading of the paper.
2. A paper handler comprising: a first inclined conveyor including a first belt operating at a first speed and having an output end; a second inclined conveyor including a second belt operating at a second speed greater than the first speed and having a receiving end located at a lower elevation than the output end of the first inclined conveyor and operably positioned to receive paper output which drops in free fall from the first inclined conveyor; and air assist means for pinning paper to the first inclined conveyor.
3. A paper handler comprising: a first inclined conveyor including a first belt operating at a first speed and having an output end; a second inclined conveyor including a second belt operating at a second speed greater than the first speed and having a receiving end located at a lower elevation than the output of the first inclined conveyor and operably positioned to receive paper output which drops in free fall from the first inclined conveyor; and a blower supplying air to the first inclined conveyor and a set of louvers above the first belt directing the air such that the paper is pinned to the first belt, wherein the louvers are positioned to direct air such that paper cascading off of the output end of the first inclined conveyor is fluffed.

\* \* \* \* \*