

(19)
(12)

(KR)
(B1)

(51) 。 Int. Cl.7
H05K 13/02

(45)
(11)
(24)

2003 10 17
10-0401422
2003 09 30

(21) 10-2001-0051545
(22) 2001 08 25

(65)
(43)

2002-0018006
2002 03 07

(30) JP-P-2000-00257202 2000 08 28 (JP)

(73) 가 가 가 2 26 10

(72) 가 2 26 10 가 가

가 2 26 10 가 가

가 2 26 10 가 가

(74)

:

(54)

가 () , () .
가 . , .

3

, , , , , , , ,

1
 2
 3 (2 III-III)
 4
 5
 6
 7
 8
 9
 10
 11a 11b

*
 1: () 4a:
 2: 4b:
 2a: 4c:
 3: 20:
 4:

8 11b 가
 (51) (50) (50a) 가 (51)
 (52) (51a)가
 8-11b (52) (51a) (52)
 (51) 8 9 가 (52)
 A, B C 가 , , 가 , A, B C
 가, (51) (52) (51a) (51b) 가
 (52a) 11a (50) (50a) 11b (51a) (52) (52a)
 (52a) 가

가
 가
 가 가
 가 가
 가 가

- 3. 1 , ; , 가
- 4. 3 , 가
- 5. 1 ,
- 6. 5 , 가 가
- 7. 가 가
- 8. 7 , 가 가
- 9. 7 ,
- 10. 9 ,

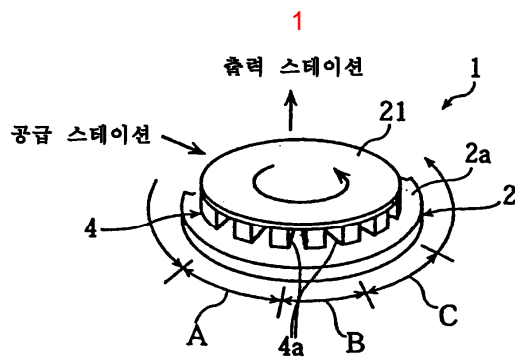

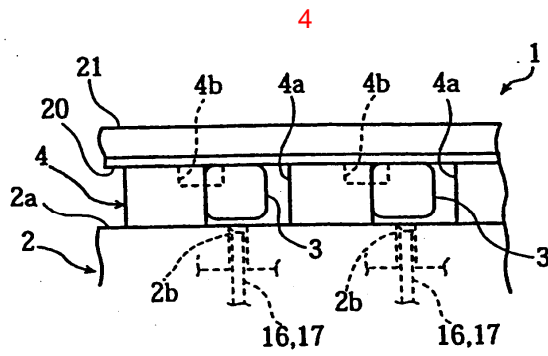
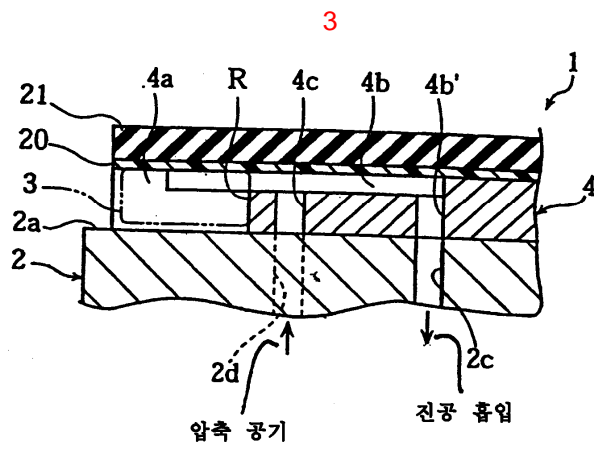
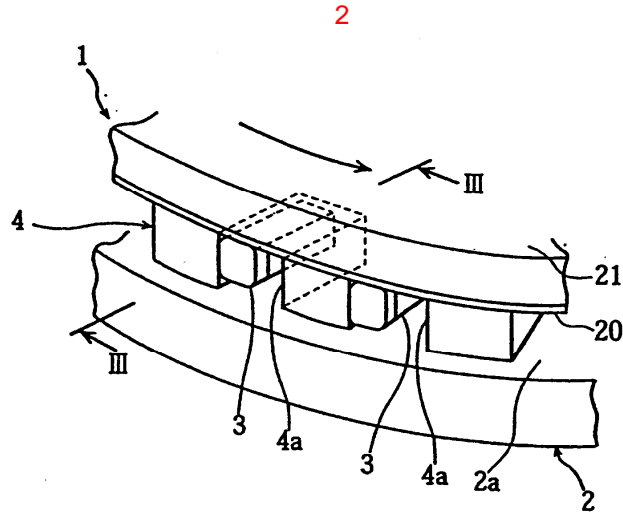

5

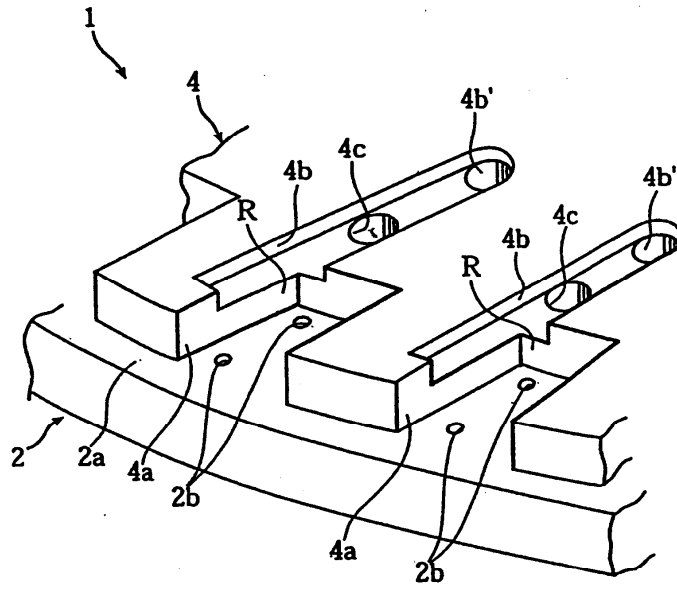

6

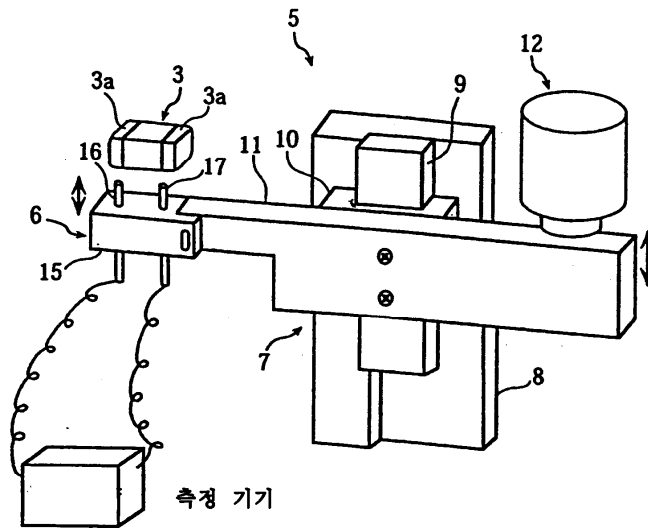

7

