



US 20040129737A1

(19) **United States**

(12) **Patent Application Publication**

Anderson et al.

(10) **Pub. No.: US 2004/0129737 A1**

(43) **Pub. Date: Jul. 8, 2004**

(54) **VALVES FOR USE IN CONTAINERS HAVING VALVE STEMS SLIDABLY MOVABLE WITHIN ROUND-EDGED SEALING RINGS**

Related U.S. Application Data

(63) Continuation of application No. 09/937,232, filed on Sep. 24, 2001.

(76) Inventors: **Gregor John, McLennan Anderson, Ware (GB); Mark Andrew Hailey, Ware (GB); David Joseph Russell, Ware (GB); James William Godfrey, Ware (GB)**

(30) **Foreign Application Priority Data**

Mar. 24, 1999 (GB)..... 9906640.9

Publication Classification

(51) **Int. Cl.⁷** **B65D 83/14**

(52) **U.S. Cl.** **222/402.24**

(57) **ABSTRACT**

There is provided a valve for an aerosol container. The valve comprises a valve body; within the valve body, a sealing ring and receiveable by the sealing ring, a valve stem having a dispensing passage. The valve stem is slidably movable within the sealing ring from a valve-closed position to a valve-open position in which the interior of the valve body is in communication with the dispensing passage. The sealing ring is shaped such as to reduce the contact area between the sealing ring and the valve stem. Preferably, the valve is a metering valve.

Correspondence Address:

DAVID J LEVY, CORPORATE INTELLECTUAL PROPERTY GLAXOSMITHKLINE FIVE MOORE DR., PO BOX 13398 RESEARCH TRIANGLE PARK, NC 27709-3398 (US)

(21) Appl. No.: **10/739,664**

(22) Filed: **Dec. 18, 2003**

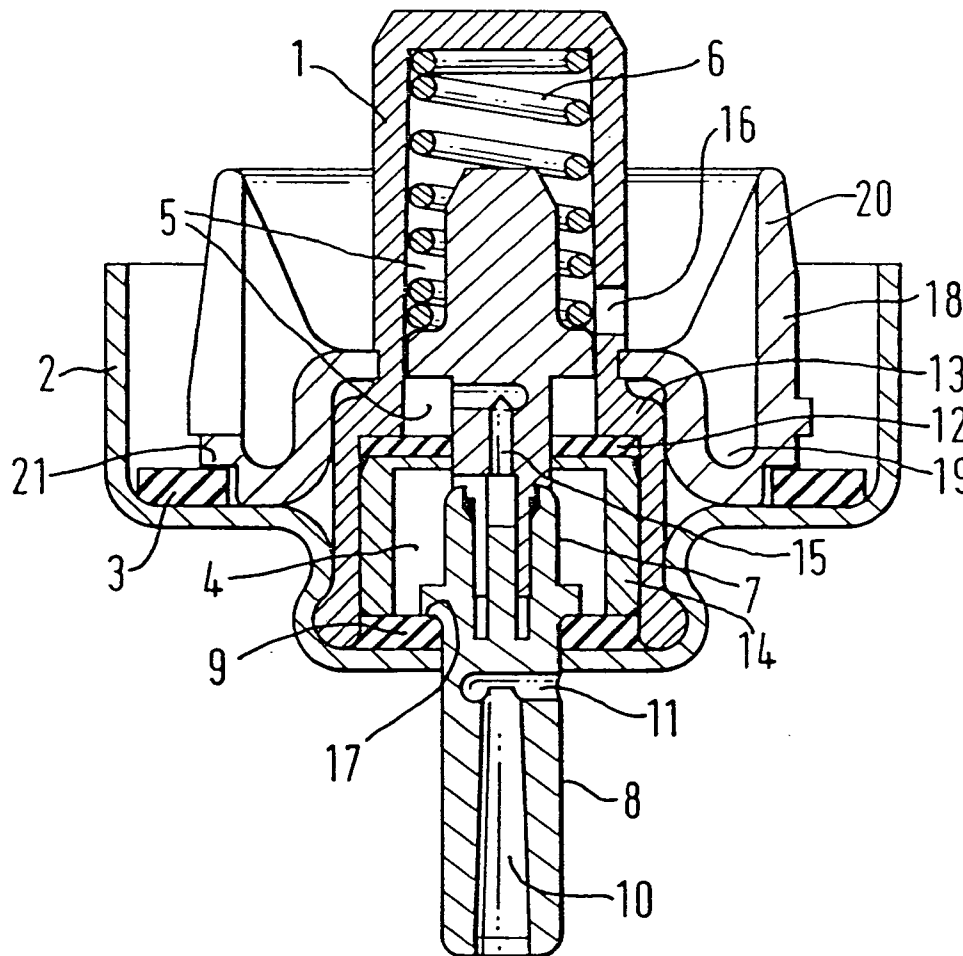

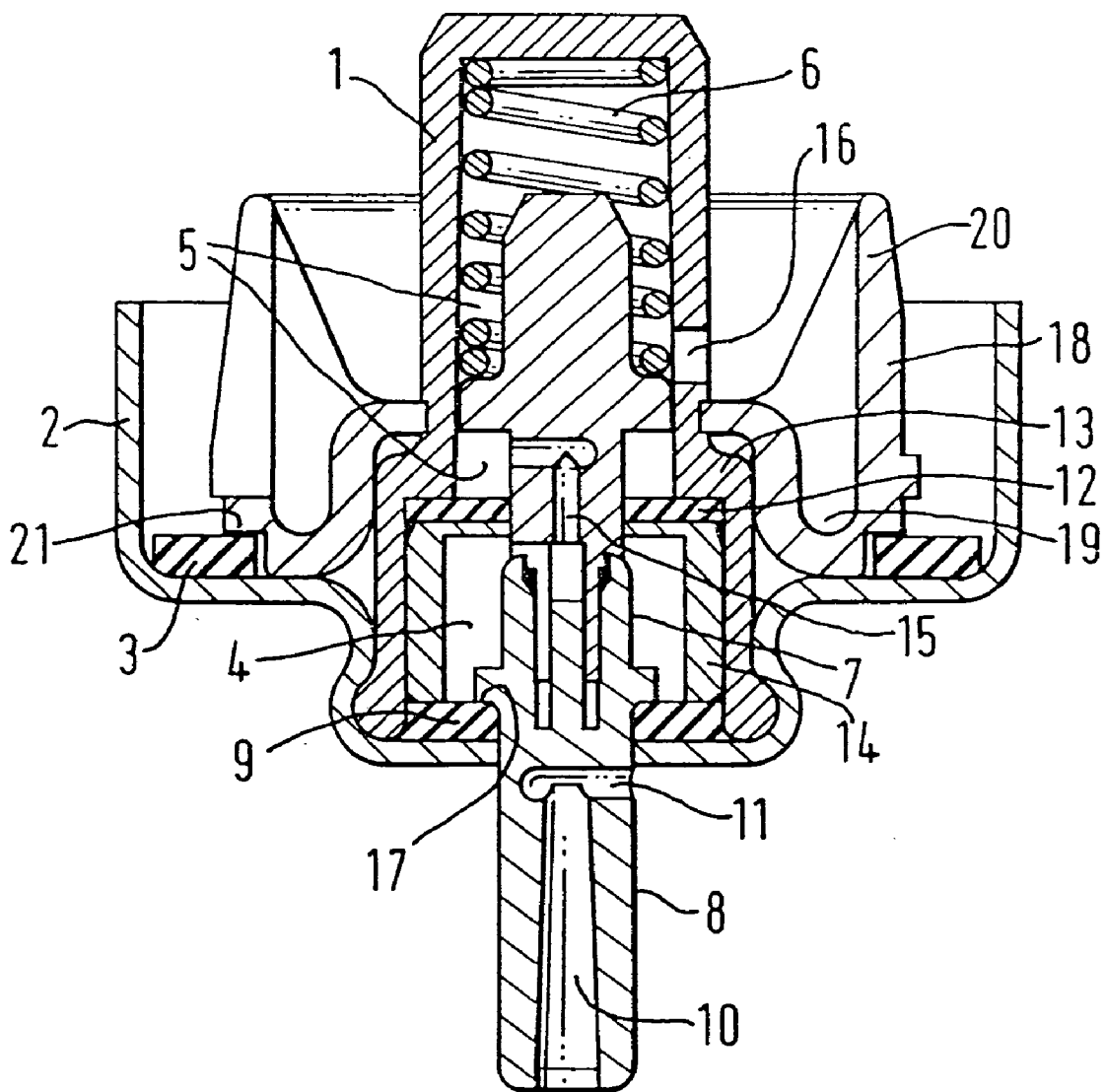

FIG. 1.

FIG. 2.

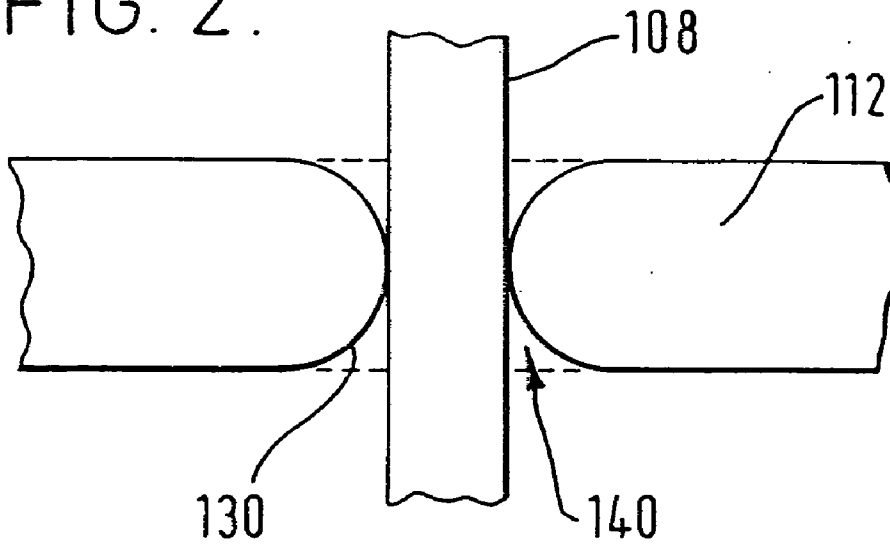
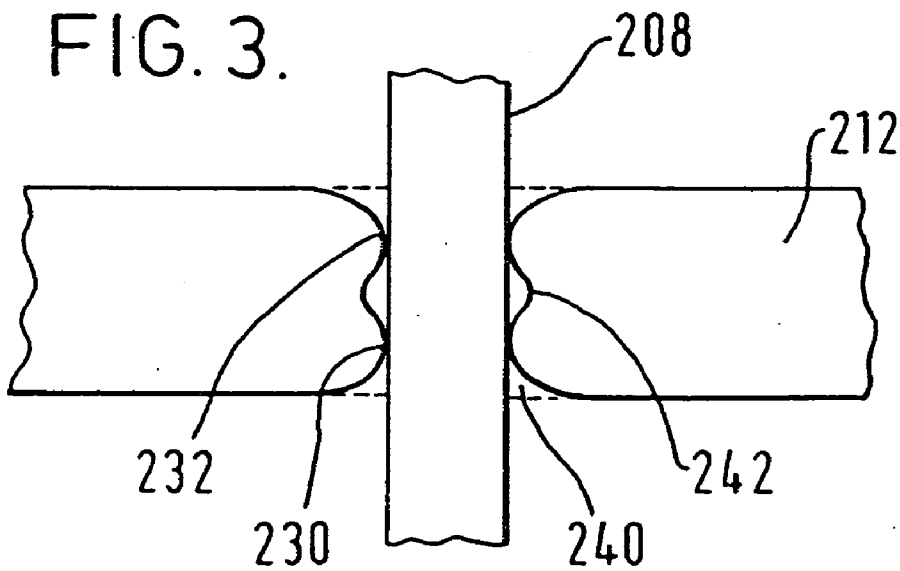
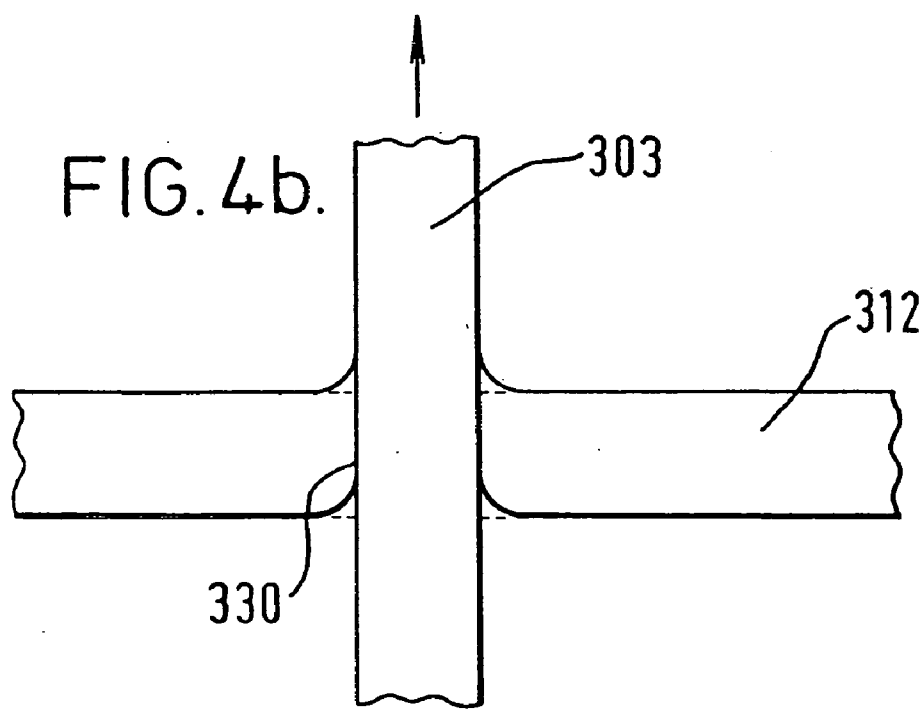
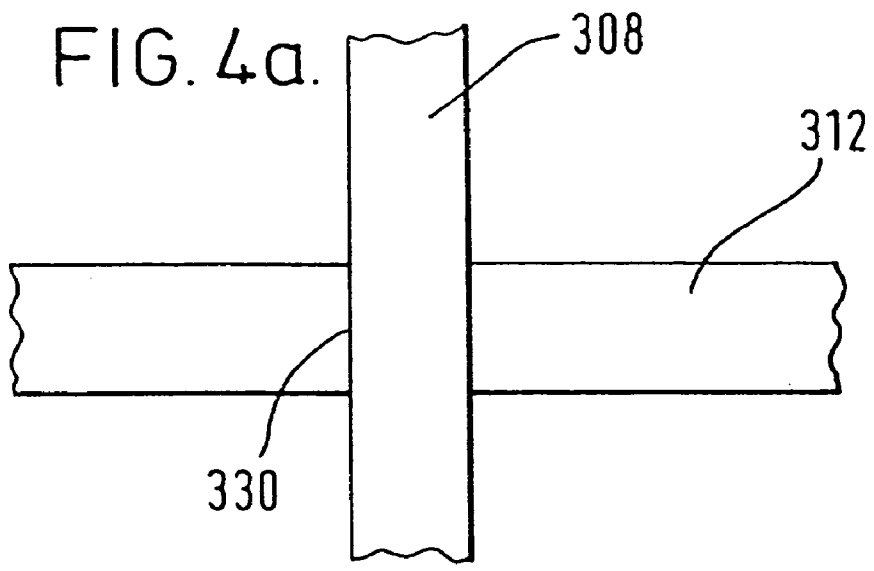

FIG. 3.





**VALVES FOR USE IN CONTAINERS HAVING
VALVE STEMS SLIDABLY MOVABLE WITHIN
ROUND-EDGED SEALING RINGS**

[0001] This invention relates to a valve for an aerosol container with the aid of which a quantity of the contents thereof can be dispensed. The invention has particular application to the dispensing of metered doses of medicaments, though it is applicable to the dispensing of aerosols generally.

[0002] Containers for aerosol formulations commonly comprise a vial body coupled to a valve. The valve comprises a valve stem through which the formulation is dispensed. Generally the valve includes a rubber valve seal intended to allow reciprocal movement of the valve stem while preventing leakage of propellant from the container.

[0003] It has been found that in some conventional devices the valve stem tends to stick, pause, or drag during the actuation cycle with the result that the valve stem may not move smoothly, particularly when released. This may be partly caused by the drug sedimenting or precipitating out of the drug-propellant suspension or solution formulation and depositing on the internal valve components, the presence of drug on the sliding interface creating increased friction during operation.

[0004] Prior art seals generally comprise a rubber ring formed by stamping out a ring shape from a sheet of rubber material. The ring aperture, thus, inevitably has square-cut edges which present a relatively high area of contact between the seal and the stem. Furthermore, when the valve stem is moved in such square-cut seals the seal deforms in such a way that the surface area, and hence the frictional contact area, between the seal and stem increases.

[0005] The Applicants have now found that the above described problem may be ameliorated without compromising sealing performance if the valve seal is shaped such as to reduce the area of contact between the seal and the stem. If a manufacturing process based upon moulding is employed a ring may be formed having a ring aperture with rounded or otherwise shaped edges. When such a rounded or shaped-edge ring is used as a valve seal the area of contact between the seal and the stem is less than that for a ring of equivalent thickness having square-cut edges. On movement of the stem within the seal there is also less tendency for the seal to deform such as to increase the contact area between the seal and the stem.

[0006] According to the present invention there is provided a valve for an aerosol container, the valve comprising a valve body; within said valve body, a sealing ring; and receivable by said sealing ring, a valve stem having a dispensing passage, the valve stem being slidably movable within the sealing ring from a valve-closed position to a valve-open position in which the interior of the valve body is in communication with the dispensing passage, wherein the sealing ring is shaped such as to reduce the contact area between the sealing ring and the valve stem.

[0007] Preferably, the area of contact between the sealing ring and the valve stem is less than 90%, more preferably less than 70%, most preferably less than 50% of what the area of contact would be if the stem-receiving aperture of the sealing ring had square-cut edges.

[0008] Preferably, the sealing ring is formable by a moulding process.

[0009] Preferably, the moulding process is injection moulding.

[0010] Alternatively, the moulding process is compression moulding.

[0011] Alternatively, the moulding process is transfer moulding.

[0012] Preferably, the sealing ring is not movable relative to the valve body, that is to say it is somehow fixed thereto. More preferably, the sealing ring is held within a cavity in the valve body.

[0013] In one aspect, the stem-receiving part of the sealing ring has at least one rounded edge, preferably all stem-receiving edges are rounded.

[0014] In another aspect, the stem-receiving part of the sealing ring presents a lobed surface to the stem. That is to say the surface comprises one or more lobe features. Preferably, the lobed surface and the stem-receiving part of the stem define one or more wells. More preferably, the one or more wells contain lubricant material therein.

[0015] Preferably, the valve is a metering valve in which the valve body has a metering chamber, a sampling chamber and therebetween is provided a second sealing ring within which the stem is slidably movable, the valve stem having a transfer passage such that in the valve-closed position the dispensing passage is isolated from the metering chamber and the metering chamber is in communication with the sampling chamber via said transfer passage, and in the valve-open position the dispensing passage is in communication with the metering chamber and the transfer passage is isolated from the metering chamber, wherein the second sealing ring is shaped such as to reduce the contact area between the second sealing ring and the valve stem.

[0016] Preferably, the area of contact between the second sealing ring and the valve stem is less than 90%, more preferably less than 70%, most preferably less than 50% of what the area of contact would be if the stem-receiving aperture of the second sealing ring had square-cut edges.

[0017] Preferably, the sealing ring and any second sealing ring is formable by a moulding process.

[0018] Preferably, the moulding process is injection moulding.

[0019] Alternatively, the moulding process is compression moulding.

[0020] Alternatively, the moulding process is transfer moulding.

[0021] Preferably, the second sealing ring is not movable relative to the valve body.

[0022] More preferably, the second sealing ring is held within a cavity in the valve body.

[0023] In one aspect, the stem-receiving part of the second sealing ring has at least one rounded edge, preferably all stem-receiving edges are rounded.

[0024] In another aspect, the stem-receiving part of the second sealing ring presents a lobed surface to the stem.

Preferably, the lobed surface and the stem-receiving part of the stem define one or more wells. More preferably, the one or more wells contain lubricant material therein.

[0025] Preferably the sealing ring and/or second sealing ring comprises an elastomeric material. The ring is typically resiliently deformable.

[0026] The elastomeric material may either comprise a thermoplastic elastomer (TPE) or a thermoset elastomer which may optionally be cross-linked. The sealing ring may also comprise a thermoplastic elastomer blend or alloy in which an elastomeric material is dispersed in a thermoplastic matrix. The elastomers may optionally additionally contain conventional polymer additives such as processing aids, colorants, tackifiers, lubricants, silica, talc, or processing oils such as mineral oil in suitable amounts.

[0027] Suitable thermoset rubbers include butyl rubbers, chloro-butyl rubbers, bromo-butyl rubbers, nitrile rubbers, silicone rubbers, fluoro-silicone rubbers, fluorocarbon rubbers, polysulphide rubbers, polypropylene oxide rubbers, isoprene rubbers, isoprene-isobutene rubbers, isobutylene rubbers or neoprene (polychloroprene) rubbers.

[0028] Suitable thermoplastic elastomers comprise a copolymer of about 80 to about 95 mole percent ethylene and a total of about 5 to about 20 mole percent of one or more comonomers selected from the group consisting of 1-butene, 1-hexene, and 1-octene as known in the art. Two or more such copolymers may be blended together to form a thermoplastic polymer blend.

[0029] Another suitable class of thermoplastic elastomers are the styrene-ethylene/butylene-styrene block copolymers. These copolymers may additionally comprise a polyolefin (e.g. polypropylene) and a siloxane.

[0030] Thermoplastic elastomeric material may also be selected from one or more of the following: polyester rubbers, polyurethane rubbers, ethylene vinyl acetate rubber, styrene butadiene rubber, copolyether ester TPE, olefinic TPE, polyester amide TPE and polyether amide TPE.

[0031] Other suitable elastomers include ethylene propylene diene rubber (EPDM).

[0032] The EPDM may be present on its own or present as part of a thermoplastic elastomer blend or alloy, e.g. in the form of particles substantially uniformly dispersed in a continuous thermoplastic matrix (e.g. polypropylene or polyethylene). Commercially available thermoplastic elastomer blend and alloys include the SANTOPRENE™ elastomers. Other suitable thermoplastic elastomer blends include butyl-polyethylene (e.g. in a ratio ranging between about 2:3 and about 3:2) and butyl-polypropylene.

[0033] The above-mentioned elastomeric materials can be prepared using methods known to those skilled in the art.

[0034] Preferably, the sealing ring and/or the second sealing ring additionally comprises lubricant material. Suitably, the sealing ring and/or the second sealing ring comprises up to 30%, preferably from 5 to 20% lubricant material.

[0035] Preferably, the stem comprises lubricant material. Suitably, the valve stem comprises up to 30%, preferably from 5 to 20% lubricant material.

[0036] The term 'lubricant' herein means any material which reduces friction between the valve stem and seal. Suitable lubricants include silicone oil or a fluorocarbon polymer such as polytetrafluoroethane (PTFE) or fluoroethylene propylene (FEP).

[0037] Lubricant can be applied to the stem, sealing ring or second sealing ring by any suitable process including coating and impregnation, such as by injection or a tamponage process.

[0038] According to another aspect of the present invention, there is provided an aerosol container comprising a valve as described hereinabove.

[0039] Preferably, the aerosol container comprises a suspension of a medicament in a propellant.

[0040] Preferably, the propellant is liquefied HFA134a or HFA-227 or mixtures thereof.

[0041] Preferably, the medicament is selected from albuterol, salmeterol, fluticasone propionate, beclomethasone dipropionate and ipratropium bromide and salts or solvates thereof and any combination thereof.

[0042] The invention will now be described further with reference to the accompanying drawing in which:

[0043] FIG. 1 is a section through a metering valve according to the invention;

[0044] FIG. 2 is a close-up sectional view of a seal-stem contact point in a valve according to the invention;

[0045] FIG. 3 is a close-up sectional view of a seal-stem contact point in a valve according to the invention;

[0046] FIG. 4a is a close-up sectional view of a seal-stem contact point in a prior art valve in a rest position; and

[0047] FIG. 4b is a close-up sectional view of a seal-stem contact point in the valve of FIG. 4a in an active position.

[0048] A valve according to the invention is shown in FIG. 1 and comprises a valve body 1 sealed in a ferrule 2 by means of crimping, the ferrule itself being set on the neck of a container (not shown) with interposition of a gasket 3 in a well-known manner. The container is loadable with a suspension of medicament, such as salmeterol xinafoate in liquid propellant HFA134a.

[0049] The valve body 1 is formed at its lower part with a metering chamber 4, and its upper part with a sampling chamber 5 which also acts as a housing for a return spring 6. The words "upper" and "lower" are used for the container when it is in a use orientation with the neck of the container and valve at the lower end of the container which corresponds to the orientation of the valve as shown in FIG. 1. Inside the valve body 1 is disposed a valve stem 7, a part 8 of which extends outside the valve through lower stem seal 9 and ferrule 2. The stem part 8 is formed with an inner axial or longitudinal canal 10 opening at the outer end of the stem and in communication with a radial passage 11.

[0050] The upper portion of stem 7 has a diameter such that it can pass slidably through an opening in an upper stem seal 12 and will engage the periphery of that opening sufficiently to provide a seal. The stem seals 9 and 12 are made by a moulding process and have rounded points of contact with the valve stem 7. Upper stem seal 12 is held in

position against a step 13 formed in the valve body 1 between the said lower and upper parts by a sleeve 14 which defines the metering chamber 4 between lower stem seal 9 and upper stem seal 12. The valve stem 7 has a passage 15 which, when the stem is in the inoperative position shown, provides a communication between the metering chamber 4 and sampling chamber 5, which itself communicates with the interior of the container via orifice 16 formed in the side of the valve body 1.

[0051] Valve stem 7 is biased downwardly to the inoperative position by return spring 6 and is provided with a shoulder 17 which abuts against lower stem seal 9. In the inoperative position as shown in FIG. 1 shoulder 17 abuts against lower stem seal 9 and radial passage 11 opens below lower stem seal 9 so that the metering chamber 4 is isolated from canal 10 and suspension inside cannot escape.

[0052] A ring 18 having a "U" shaped cross section extending in a radial direction is disposed around the valve body below orifice 16 so as to form a trough 19 around the valve body. As seen in FIG. 1 the ring is formed as a separate component having an inner annular contacting rim of a diameter suitable to provide a friction fit over the upper part of valve body 1, the ring seating against step 13 below the orifice 16. However, the ring 18 may alternatively be formed as an integrally moulded part of valve body 1.

[0053] To use the device the container is first shaken to homogenise the suspension within the container. The user then depresses the valve stem 7 against the force of the spring 6. When the valve stem is depressed both ends of the passage 15 come to lie on the side of upper stem seal 12 remote from the metering chamber 4. Thus a dose is metered within the metering chamber. Continued depression of the valve stem will move the radial passage 11 into the metering chamber 4 while the upper stem seal 12 seals against the valve stem body. Thus, the metered dose can exit through the radial passage 11 and the outlet canal 10.

[0054] Releasing the valve stem causes it to return to the illustrated position under the force of the spring 6. The passage 15 then once again provides communication between the metering chamber 4 and sampling chamber 5. Accordingly, at this stage liquid passes under pressure from the container through orifice 16, through the passage 15 and thence into the metering chamber 4 to fill it.

[0055] FIG. 2 shows a cut-away detail of a seal-stem contact point of a valve herein. The upright valve stem 108 which has a circular cross-section is sealingly contacted by a sealing ring 112. The ring aperture 130 of the sealing ring 112 has rounded edges. It may be understood that the area of contact of the ring 112 with the stem 108 is less than it would be if the ring 112 had square-cut edges. When the stem 108 is moved upwards, the ring 112 will tend to flex into free-space 140.

[0056] FIG. 3 shows a cut-away detail of a seal-stem contact point of a second valve herein. The upright valve stem 208 which has a circular cross-section is sealingly contacted by a sealing ring 212. The ring aperture of the sealing ring 212 is edged by two rounded lobes 230, 232. The area of contact of the ring 212 with the stem 208 is less than it would be if the ring 212 had square-cut edges. When the stem 208 is moved within the ring 212, the ring 212 will tend to flex into free-space 240 and well 242. The well 242 may be wholly or partially filled with a lubricant material.

[0057] FIGS. 4a and 4b show a cut-away detail of a seal-stem contact point of a prior art valve, wherein FIG. 4a shows a rest configuration and FIG. 4b shows the configuration when the valve is in an active position. The upright valve stem 308 which has a circular cross-section is sealingly contacted by a sealing ring 312. The ring aperture 330 of the sealing ring 312 has square-cut edges 330. When the stem is moved upwards as shown in FIG. 4b, the ring 312 is deformed and spreads out such that the area of contact between the ring 312 and the stem 308 is increased. The frictional contact between the ring 312 and stem is thus, also increased.

[0058] It may be appreciated that a number of different configurations of the sealing ring are possible, in addition to those described in FIGS. 2 and 3, in which the contact area between the sealing ring and the valve stem is reduced. One possible configuration is similar to that shown in FIG. 3 but the ring aperture is edged by more than 2 lobes. Another possible configuration has a sealing ring aperture with straight tapered edges leading to a point (such that its cross section is triangular in shape) which has reduced contact with the valve stem compared to straight cut edges. A lobed version of this sealing ring is also possible wherein there are two or more lobes each tapered to a point. A further configuration which reduces the contact area with the valve stem has sections of the top and bottom sides of the ring aperture cut away to leave a smaller projecting portion to form a seal with the valve stem. The projecting portion may have straight cut or shaped edges. Cutting one or more grooves or small channels in the non stem-receiving surfaces of the sealing ring provides space for the stem-receiving part of the sealing ring to move into upon movement of the valve stem, resulting in reduced deformation and friction at the contact surface with the valve stem.

[0059] It may be appreciated that any of the parts of the metering valve which contact the medicament suspension may be coated with materials such as fluoropolymer materials which reduce the tendency of medicament to adhere thereto. Suitable fluoropolymers include polytetrafluoroethylene (PTFE) and fluoroethylene propylene (FEP). Any movable parts may also have coatings applied thereto which enhance their desired movement characteristics. Frictional coatings may therefore be applied to enhance frictional contact and lubricants used to reduce frictional contact as necessary.

[0060] The aerosol container and valve of the invention is suitable for dispensing medicament, particularly for the treatment of respiratory disorders such as asthma and chronic obstructive pulmonary disease (COPD).

[0061] Appropriate medicaments may thus be selected from, for example, analgesics, e.g., codeine, dihydromorphine, ergotamine, fentanyl or morphine; angular preparations, e.g., diltiazem; antiallergics, e.g., cromoglycate, ketotifen or nedocromil; antiinfectives e.g., cephalosporins, penicillins, streptomycin, sulphonamides, tetracyclines and pentamidine; antihistamines, e.g., methapyrilene; anti-inflammatories, e.g., beclomethasone dipropionate, fluticasone propionate, flunisolide, budesonide, rofleponide, mometasone furoate or triamcinolone acetonide; antitussives, e.g., noscapine; bronchodilators, e.g., albuterol, salmeterol, ephedrine, adrenaline, fenoterol, formoterol, isoprenaline, metaproterenol, phenylephrine,

phenylpropanolamine, pirbuterol, reproterol, rimeterol, terbutaline, isoetharine, tulobuterol, or (-)-4-amino-3,5-dichloro- α -[[[6-[2-(2-pyridinyl)ethoxy]hexyl]methyl] benzenemethanol; diuretics, e.g., amiloride; anticholinergics, e.g., ipratropium, tiotropium, atropine or oxitropium; hormones, e.g., cortisone, hydrocortisone or prednisolone; xanthines, e.g., aminophylline, choline theophyllinate, lysine theophyllinate or theophylline; therapeutic proteins and peptides, e.g., insulin or glucagon. It will be clear to a person skilled in the art that, where appropriate, the medicaments may be used in the form of salts, (e.g., as alkali metal or amine salts or as acid addition salts) or as esters (e.g., lower alkyl esters) or as solvates (e.g., hydrates) to optimise the activity and/or stability of the medicament.

[0062] Preferred medicaments are selected from albuterol, salmeterol, fluticasone propionate and beclomethasone dipropionate, and ipratropium bromide and salts or solvates thereof, e.g., the sulphate of albuterol and the xinafoate of salmeterol.

[0063] Medicaments can also be delivered in combinations. Preferred formulations containing combinations of active ingredients contain salbutamol (e.g., as the free base or the sulphate salt) or salmeterol (e.g., as the xinafoate salt) in combination with an anti-inflammatory steroid such as a beclomethasone ester (e.g., the dipropionate) or a fluticasone ester (e.g., the propionate).

[0064] It will be understood that the present disclosure is for the purpose of illustration only and the invention extends to modifications, variations and improvements thereto.

[0065] The application of which this description and claims form part may be used as a basis for priority in respect of any subsequent application. The claims of such subsequent application may be directed to any feature or combination of features described therein. They may take the form of product, method or use claims and may include, by way of example and without limitation, one or more of the following claims:

1. Valve for an aerosol container, the valve comprising a valve body; within said valve body, a sealing ring; and receivable by said sealing ring, a valve stem having a dispensing passage, the valve stem being slidably movable within the sealing ring from a valve-closed position to a valve-open position in which the interior of the valve body is in communication with the dispensing passage, wherein the sealing ring is shaped such as to reduce the contact area between the sealing ring and the valve stem.

2. Valve according to claim 1, wherein the area of contact between the sealing ring and the valve stem is less than 90% of what the area of contact would be if the sealing ring had square-cut edges.

3. Valve according to either of claims 1 or 2, wherein the sealing ring is formable by a moulding process.

4. Valve according to claim 3 wherein the moulding process is injection moulding.

5. Valve according to claim 3 wherein the moulding process is compression moulding.

6. Valve according to claim 3 wherein the moulding process is transfer moulding.

7. Valve according to any of claims 1 to 6, wherein the sealing ring is not movable relative to the valve body.

8. Valve according to claim 7, wherein the sealing ring is held within a cavity in the valve body.

9. Valve according to any of claims 1 to 8, wherein the stem-receiving part of the sealing ring has at least one rounded edge.

10. Valve according to any of claims 1 to 9, wherein the stem-receiving part of the sealing ring presents a lobed surface to the stem.

11. Valve according to claim 10, wherein the lobed surface and the stem-receiving part of the stem define one or more wells.

12. Valve according to claim 11, wherein said one or more wells contain lubricant material therein.

13. Valve according to any of claims 1 to 12, wherein the valve body has a metering chamber, a sampling chamber and therebetween is provided a second sealing ring within which the stem is slidably movable, the valve stem having a transfer passage such that in the valve-closed position the dispensing passage is isolated from the metering chamber and the metering chamber is in communication with the sampling chamber via said transfer passage, and in the valve-open position the dispensing passage is in communication with the metering chamber and the transfer passage is isolated from the metering chamber, wherein the second sealing ring is shaped such as to reduce the contact area between the second sealing ring and the valve stem.

14. Valve according to claim 13, wherein the area of contact between the second sealing ring and the valve stem is less than 90% of what the area of contact would be if the second sealing ring had square-cut edges.

15. Valve according to either of claims 13 or 14, wherein the second sealing ring is formable by a moulding process.

16. Valve according to claim 15 wherein the moulding process is injection moulding.

17. Valve according to claim 15 wherein the moulding process is compression moulding.

18. Valve according to claim 15 wherein the moulding process is transfer moulding.

19. Valve according to any of claims 13 to 18, wherein the second sealing ring is not movable relative to the valve body.

20. Valve according to claim 19, wherein the second sealing ring is held within a cavity in the valve body.

21. Valve according to any of claims 13 to 20, wherein the stem-receiving part of the second sealing ring has at least one rounded edge.

22. Valve according to any of claims 13 to 21, wherein the stem-receiving part of the second sealing ring presents a lobed surface to the stem.

23. Valve according to claim 22, wherein the lobed surface and the stem-receiving part of the stem define one or more wells.

24. Valve according to claim 23, wherein said one or more wells contain lubricant material therein.

25. Valve according to any of claims 1 to 24 wherein the sealing ring comprises an elastomeric material.

26. Valve according to any of claims 13 to 25 wherein the second sealing ring comprises an elastomeric material.

27. Valve according to claims 25 and 26 wherein the elastomeric material is selected from the group consisting of

- (a) a thermoplastic elastomer comprising a copolymer of about 80 to about 95 mole percent ethylene and a total of about 5 to about 20 percent mole percent of one or more of 1-butene, 1-hexene and 1-octene;
- (b) a styrene-ethylene/butylene-styrene block copolymer;
- (c) an ethylene propylene diene rubber (EPDM)

(d) a thermoplastic elastomer blend of EPDM dispersed in a polypropylene or polyethylene matrix;

(e) a butyl polyethylene;

(f) a butyl-polypropylene; and any mixtures thereof.

28. Valve according to any of claims 1 to 27, wherein the sealing ring additionally comprises lubricant material.

29. Valve according to any of claims 13 to 28, wherein the second sealing ring additionally comprises lubricant material.

30. Valve according to any of claims 1 to 29, wherein the stem comprises lubricant material.

31. Aerosol container comprising a valve according to any of claims 1 to 30.

32. Aerosol container according to claim 31 comprising a suspension of a medicament in a propellant.

33. Aerosol container according to claim 32, wherein, the propellant is liquefied HFA134a or HFA-227 or mixtures thereof.

34. Aerosol container according to either of claims **32** or **33**, wherein the medicament is selected from the group consisting of albuterol, salmeterol, fluticasone propionate, beclomethasone dipropionate, ipratropium bromide and salts or solvates thereof and any combination thereof.

* * * * *