

Oct. 7, 1969

W. A. SCHEUBLEIN, JR., ET AL

3,470,721

COIL SPRING WINDING MACHINE

Filed Jan. 3, 1967

2 Sheets-Sheet 1

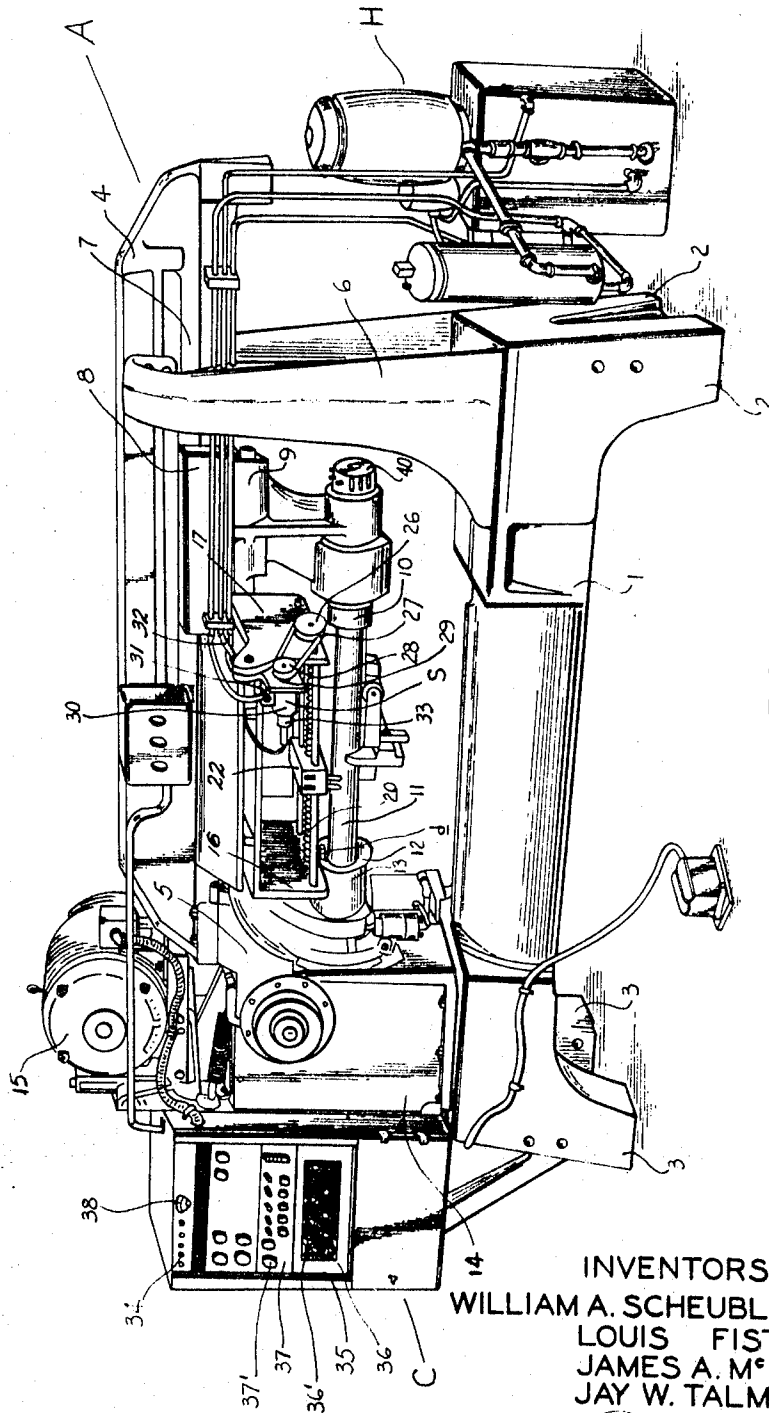

FIG. 1

INVENTORS:
WILLIAM A. SCHEUBLEIN, JR.
LOUIS FISTER
JAMES A. McNEELY
JAY W. TALMAGE

BY: *Ralph W. Kalish*
ATTORNEY

Oct. 7, 1969

W. A. SCHEUBLEIN, JR., ET AL

3,470,721

COIL SPRING WINDING MACHINE

Filed Jan. 3, 1967

2 Sheets-Sheet 2

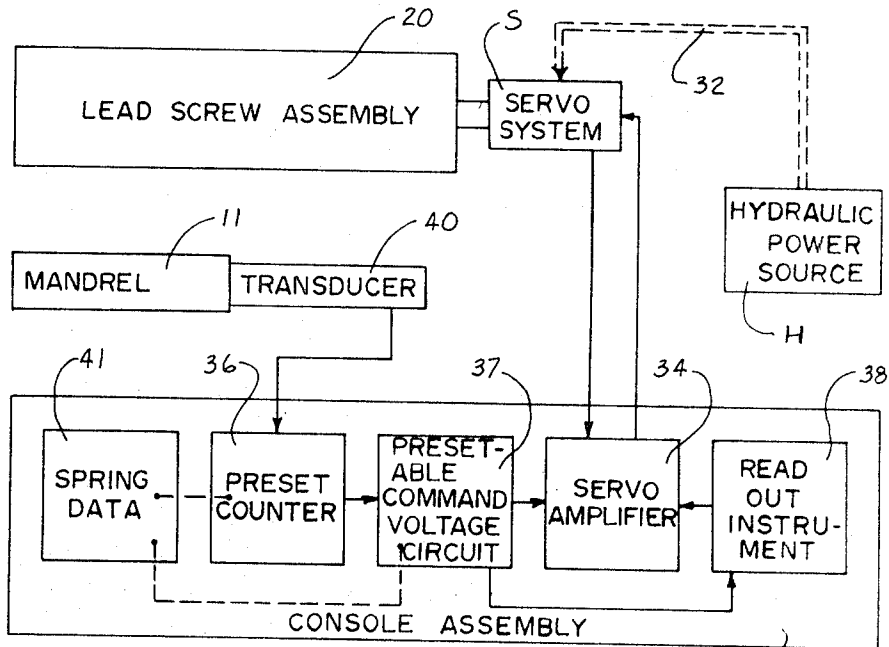

FIG. 2

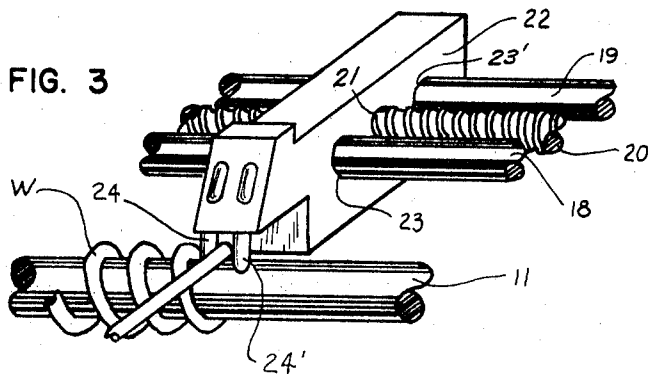

FIG. 3

INVENTORS:
WILLIAM A. SCHEUBLEIN, JR.
LOUIS FISTER
JAMES A. M'NEELY
JAY W. TALMAGE

BY: *Ralph M. Kalish*
ATTORNEY

1

3,470,721

COIL SPRING WINDING MACHINE

William A. Scheublein, Jr., Ballwin, Louis Fister, St. Louis, James A. McNeely, Manchester, and Jay W. Talmage, Berkeley, Mo., assignors to Moog Industries, Inc., St. Louis, Mo., a corporation of Missouri
Filed Jan. 3, 1967, Ser. No. 611,210

Int. Cl. B21f 3/04

U.S. Cl. 72-144

12 Claims

ABSTRACT OF THE DISCLOSURE

A machine for the winding of coil springs having a rotatable mandrel and a rod stock guide movable linearly of the mandrel for guiding the stock for winding thereabout. The rate of travel of the bar or rod stock guide is controlled by an electro-hydraulic system with the constant speed rotary motion of the mandrel serving as a commanding source so that changes in the rate of travel of the bar or rod stock guide may be effected for pitch control of the spring to be formed.

BACKGROUND OF THE INVENTION

This invention relates in general to spring coiling and, in particular, to a machine for effecting the coil winding of springs primarily adapted for use in automobile suspensions.

Heretofore in the manufacture of hot wound helical compression coil springs a lead screw consisting of a round bar with spiral grooves formed therein has been requisite. Such lead screw thus controls the bar as it is being coiled with the depths of the grooves depending upon the bar diameter of the particular spring. As the spring is coiled the rod or bar stock will be led by the grooves in the lead screw for coiling about a mandrel located below the lead screw.

As is well known, the variety of coil springs is myriad; there being two broad classifications, namely, variable pitch and constant pitch, but with the combinations within each such grouping being infinite. Accordingly, for production of any particular coil spring the manufacturer must have available a lead screw with the appropriately formed grooves therein and being of requisite dimension for the particular bar diameter of the spring. In order to have the capability of producing a wide range of springs, there must necessarily be a corresponding inventory of lead screws. The installation of a lead screw within a conventional coiling machine and the removal of the same therefrom, are exceedingly time consuming operations which represent "down time" with respect to the machine, as well as entailing the cost of the services of the personnel effecting the changes. In view of the substantial expense of such lead screws, manufacturers are, understandably, reluctant to produce at any one time relatively small quantities of any particular spring since the set-up time militates against the economy of the operation. The prior art machines of the character just referred to are similar to the relatively well known "Gogan Coiler," as set forth in United States Patent No. 3,000,427. With the present invention, the use of the lead screw with appropriate spiral formations therein is entirely eliminated so that there is no longer the necessity of maintaining an inventory of lead screws and with the attendant obviation of changing lead screws.

SUMMARY OF INVENTION

It is an object of the present invention to provide a machine for producing compression coil springs having a mandrel to which is fed spring stock at a predetermined

2

rate by means of a guide movable linearly of the said mandrel.

It is another object of the present invention to provide a machine of the type stated which incorporates a coiling mandrel driven at a constant speed of rotation and having means operated thereby for effecting the rate of presentation of spring stock thereto for pitch control.

It is another object of the present invention to provide a machine of the character stated which incorporates electro-hydraulic means for connecting the coiling mandrel and the spring stock guiding member.

It is a still further object of the present invention to provide a machine of the character stated which incorporates a pre-settable control for an electro-hydraulic system for effecting changes in rate of travel for a guide for the spring stock whereby a spring of predetermined pitch characteristics may be automatically formed.

It is still another object of the present invention to provide a machine of the type stated which eliminates the need of a lead screw for each type of coil spring to be formed and which is adapted to form coil springs of any predetermined pitch characteristic by utilization of a coiling mandrel and an electro-hydraulic lead screw; which may be most economically manufactured; which may be adapted for use with various types of coiling equipment; which is markedly economical in production so that short runs may be easily accommodated.

BRIEF DESCRIPTION OF DRAWINGS

FIGURE 1 is a front perspective view of a coil spring winding machine constructed in accordance with and embodying the present invention.

FIGURE 2 is a block diagram of the primary components of the machine.

FIGURE 3 is a fragmentary perspective view illustrating the relationship of the lead screw to the mandrel during the winding operation.

DESCRIPTION OF THE PREFERRED EMBODIMENT

Referring now by reference numerals to the drawings which illustrate the preferred embodiment of the present invention, A generally designates a spring winding machine adapted for producing coil springs, such as are used for automobile suspensions, and which comprises a bed 1 supported by legs 2, 3; there being an overhead member 4 mounted on upstanding brackets 5, 6 disposed on bed 1. Overhead member 4 has formed, on opposite sides thereof, cooperating longitudinally progressing ways 7 for sliding engagement with slide bodies 8 formed integral with, and provided at the upper end of, a tailstock 9 whereby the latter is reciprocally movable along said ways 7. Tailstock 9 is provided with a bearing 10 for journalling the outer end of a mandrel 11, the opposite or inner end of which is rotatably supported by the chuck portion 12 of a spindle 13 which is rotatable by means of a conventional gear train (not shown) within a reduction gear box 14; said train being driven, through suitable transmitting means, by a motor 15 which may be disposed on top of gear box 14 for purposes of compactness.

Tailstock 9 is operatively connected to a fluid pressure actuated motor (not shown) of conventional design and being adapted for operation by either liquid or air and which may be mounted on the rear face of overhead member 4 having the usual connecting rods for engaging tailstock 9 to the motor piston. By operation of said fluid pressure actuated motor, tailstock 9 will be moved outwardly along ways 7 carrying mandrel 11 therewith so as to effect disengagement of the inner end thereof from chuck 12 for allowing release of the work formed on mandrel 11 as will be described more fully hereinbelow. The fluid pressure actuated motor may be adapted for

timed sequential operation so as to effect a return stroke for restoring mandrel 11 to operative engagement within chuck 12 for the succeeding work forming operation.

Depending from overhead member 4 is a pair of longitudinally spaced-apart, transversely extending mounting plates 16, 17 with the spacing between same coinciding with the effective length of mandrel 11, that is, between chuck 12 and the inner end of tailstock 9; both of said plates 16, 17 projecting laterally beyond mandrel 11 on either side thereof. Extending between the lower outer portions of mounting plates 16, 17 and being fixed at their ends therein is a pair of parallel guide rods 18, 19. Intermediate of, and axially parallel with, guide rods 18, 19, is a lead screw 20 for presentation in overlying, vertically spaced relationship to mandrel 11 with the axes thereof being substantially within the same vertical plane, said lead screw being journalled at its ends within plates 16, 17 in bearings formed therein.

Lead screw 20 threadedly engages a tapped opening 21 in the block-like body of a bar guide or carriage 22 having axially parallel, smooth-bore openings 23, 23' for respectively slideably receiving guide rods 18, 19, which latter stabilize bar guide 20 in its traversing movement. At its forward end bar guide 22 is provided with a pair of parallel fingers 24, 24' which depend from its under surface and are disposed so that their lower portions will be presented forwardly of the upper zone of mandrel 11. Fingers 24, 24' are spaced apart a distance suitable for extension therebetween of work W in the form of hot rod stock of predetermined length and which may be of any desired cross section; said stock being fed therethrough by an operator from the front of machine A for coiling about mandrel 11 in a manner to be described below.

The forward end of lead screw 20 projects through its bearing in plate 17 and mounts a pulley 26 about which is engaged one end portion of a drive belt 27, the other end portion of which is trained about a pulley 28 carried on the drive shaft 29 of a servo motor 30 of a conventional servo mechanism S. Said mechanism S incorporates motor 30 which is of hydraulic type having desired speed and torque characteristics and a customary servovalve 31 being connected by conduits as indicated at 32 to a source of hydraulic fluid H, which latter comprehends pump means. Also embodied within mechanism S is the usual tachometer (not shown) located within the housing 33. Servovalve 31 is operationally connected to a servo amplifier or controller, which is indicated schematically 34 in FIGURE 2. In accordance with the well known operation of servo mechanisms, the electrical output of servo amplifier or controller 34 will be fed to servovalve 31 which thus connects the hydraulic power source H with motor 30 for operation of the latter. It is understood that the tachometer will assure proper motor speed with respect to the preselected voltage fed to servo amplifier 34. The speed of rotation of lead screw 20, is, as shown, directly controlled by servo mechanism S so that upon the particular input to servo amplifier or servo controller 34, the shaft of servo motor 30 will rotate at a speed predetermined by the selected input.

Provided at any suitable location with respect to machine A, such as in mounted disposition adjacent reduction gear casing 14, is a console assembly C for receiving components of the system for effecting operation of servo mechanism S and being provided with a front panel 35. The numeral 36 generally designates a pulse counter of the preset type which is designed to emit a signal after receiving an externally chosen number of input pulses, which counter embodies a control portion 36'. A presettable command voltage circuit, indicated by 37, embodies controls 37'. A read-out instrument 38 is provided in the upper central portion of panel 35 for indicating preset voltages in the system.

With reference now being made to the block diagram set forth in FIGURE 2, the relationship between the primary control components of the present invention will

become more apparent. The box bearing the legend "Lead Screw Assembly" understandably relates to lead screw 20 and bar guide 22 carried thereon; while the box bearing the notation "Servo System" comprehends servo mechanism S with servo motor 30, servovalve 31, and tachometer 33. Mandrel 11 is operatively connected to a sensing device or transducer 40 which may be of the angular encoder type for emission of electric pulses responsive to the angular displacement of mandrel 11 so that with each degree of rotation of mandrel 11 a pulse is discharged for reception by counter 36. The particular nature of sensing device 40 does not form a part of the present invention and may be of any well known character suitable for the intended purpose, such as photoelectric encoders. At this juncture it will thus be seen that the rotary motion of mandrel 11 is used as the commanding source for the operation of the present invention.

Counter 36 is also of well known design and its precise character does not constitute a part of the present invention with the same having the capacity of counting elevated speeds, such as, for instance, in the range of 120,000 pulses per minute, and being electronic for counting at rates which could not be obtained by mechanical or electromechanical counters. Being presettable, counter 36 is thus adapted to effect an operation upon reception of a predetermined signal, such as closing a switch, relay or the like; and being capable of effecting a series of operations through receipt of predetermined sequential input signals from the sensing device 40. After completion of a particular cycle, counter 36 will reset to "zero" preparatory for the next cycle. Command voltage circuit 37 which is also presettable, is suitably connected to counter 36, and incorporates a number of adjustable voltages obtained by such devices as potentiometers. As with the other elements of this system, the physical character of command voltage circuit 37 does not form a part of the present invention as the same is of widely accepted character. The potentiometers of command voltage circuit 37 may each be preset and, in accordance with common practice, are so engaged, as by relays, to the various presettings of counter 36 so that as the predetermined pulse is received by counter 36 a circuit will be closed to the preselected related potentiometer of command voltage circuit 37 to provide the pre-intended output which will be fed to servo amplifier 34 for correlative operation of servo motor 30 resulting in rotation of lead screw 20 at the related r.p.m.'s. Counter 36 is synchronized in a customary fashion with the drive system for mandrel 11 so that the operation thereof will control the start of the cycle (for formation of the spring and release of the finished spring therefrom) and will reset counter 36.

Mandrel 11 is designed to rotate at a constant predetermined speed while lead screw 20 will, in accordance with the foregoing, rotate at any of various rates so that the linear velocity of bar guide 22 will vary directly therewith. By appropriate presetting of counter 36 and command voltage circuit 37, bar guide 22 in the course of one traversing movement between plates 16, 17 may be caused to travel at a multiplicity of different rates while moving relatively to the rotating mandrel 11.

For coiling work W about mandrel 11 the hot rod stock is directed to mandrel 11 between fingers 24, 24' of bar guide 22 (see FIGURE 3) which, at the commencement of the forming operation will be presented in immediate adjacency to mounting plate 16. After passing through fingers 24, 24' and progressing beneath the forward portion of bar guide 22, the stock will be received upon the upper surface of mandrel 11 immediately adjacent chuck 12 and beneath a dog *d* mounted on chuck 12 and projecting outwardly therefrom so that the initial end of said stock will be properly maintained against displacement to assure of proper coiling action about mandrel 11. As bar guide 22 is caused to move along its linear path through resultant rotation of lead screw 20, the work W will be continually fed to mandrel 11 for

coiling thereabout. It is apparent that the relatively more rapidly bar guide 22 travels the fewer the number of coils formed and, conversely, the relatively more slowly bar guide 22 moves the relatively greater number of coils will be formed within a unit length. Thus, bar guide 22 serves as an immediate pitch control mechanism as its rate of travel regulates the distance in a longitudinal direction between the individual coils of the spring, which distance, is commonly known as "pitch." Therefore, the present invention contains the inherent potential for providing coil springs with an infinite variety in pitch. Bar guide 22 may be caused to move at a constant rate and thereby cause the development of a spring with constant pitch or, the rate of travel of bar guide 22 may be caused to effect changes at predetermined points in its travel, either increasing or decreasing its speed, so that the distances between consecutive coils will be different in accordance with a prearranged plan and thereby bring about a coil spring having the so-called variable pitch. In view of the foregoing, there will be noted the extreme criticality of the unique relationship of the rate or rates of linear travel of bar guide 22 with respect to the mandrel 11 rotating at a constant speed for bringing about the capability of producing helical compression coil springs of any preselected pitch or pitches in a most economic fashion and without requiring the heretofore accepted grooved lead screw.

Since mandrel 11 is of a fixed diameter it is understood that the same will necessarily be preselected for accommodating the inside diameter of the spring to be formed. It is recognized that a forming mandrel is capable of producing a substantial variety of coil arrangements so that the same will not require replacement with the frequency of the heretofore utilized grooved lead screw. The actual replacement of forming mandrels, however, is most speedily accomplished.

There is also provided for use with machine A a suitable reference chart as indicated at 41 in FIGURE 2, as of the roll character, and having set forth thereon the requisite spring data for proper presetting of counter 36 and command voltage circuit 37 for the particular coil spring to be produced. From chart 41 the length of each pitch of the spring is given in degrees (of rotation of mandrel 11) so that the same may be fed to counter 36 to assure of the appropriate signal at the required junctures. The predetermined helic angle of each pitch is presented on chart 41 in volts for feeding into command voltage circuit 37. Accordingly, counter 36 and command voltage circuit 37 are thereby placed in a fully preset state preparatory for the forming operation, with lead screw 20 being thus programmed for the given spring. With the related controls on console assembly C thus presented, with hydraulic power in "on" position, and with bar guide 22 adjacent plate 16, machine A is ready for spring production. The operation of the present invention will be more readily understood by resort to examples which clearly demonstrate the extreme versatility of machine A.

Example I

There is to be formed a hot wound helical compression coil spring having the following characteristics:

Bar diameter	-----inches	.610
Inside diameter of the spring	-----do	3.672
Total coils	-----turns	10.3
Free length	-----inches	16.875

The spring is to have two tangential ends with a .660 inch lead for a .667 turn. From the above characteristics the hot built height of the spring was found, in accordance with well known techniques, to be 18.93 inches. (It is understood that the hot built height of a given spring is the calculated free height plus an additional length which will be lost during sizing and preset operations of the spring.) As the spring has two tangential ends, the same will thereby have a total of three pitches, that is, one for

each of the said ends and the third for the intervening coils, which latter are thus of constant pitch. The first and third pitches are apparent from the description of the spring since they comprehend the two tangential ends which are .660 inch per turn. From the hot built height the pitch of the intervening coils, that is, in this case, the main pitch, was calculated to be 1.95 inches per turn. Since the first pitch (.660 inch) differs from that of the next or main pitch (1.95 inches) it is manifest that a commensurate change must be effected in the rate of linear travel of bar guide 22 for effecting the different pitches. Therefore, lead screw 20 will be caused to travel at one predetermined angular rate for effecting the formation of the first pitch and at a second or different rate for formation of the next or main pitch. The travel of bar guide 22 throughout the coiling between the tangential ends will be at a constant rate as the longitudinal distance between the intervening coils is the same. However, a further change of rate of travel of bar guide 22 is required for forming the second tangential end (or third pitch) as the pitch thereof differs from the immediately preceding or adjacent pitch. From chart 41, the operator learns the number of degrees of rotation of mandrel 11 requisite for each of the pitches of the particular spring and thereby accordingly presets counter 36. Similarly by reference to said chart, the helic angle for the particular pitches is learned and the corresponding volts are fed into the command voltage circuit 37. In the present instance, the "set-up" will be as follows:

Counter:	Degrees
1st pre-set	240
2nd pre-set	3468
3rd pre-set	3708
4th pre-set	Off

Command voltage circuit:	Ohms
1st potentiometer	x-1395
2nd potentiometer	x-4115
3rd potentiometer	x-1395
4th potentiometer	x-0

NOTE.—The symbol x is used herein to represent the maximum ohms of the potentiometer. In the present example the same shall be considered as 10,000 ohms.

With the system energized and the cycle commencing with rotation of mandrel 11, sensing device 40 will immediately start emitting pulses to counter 36; with the hot rod stock being simultaneously fed to mandrel 11 in the manner above discussed, as through fingers 24, 24' of bar guide 22. The initial setting of command voltage circuit 37 provides a voltage having a potentiometer reading of x-1395 ohms which is fed to serve amplifier 34 for commensurate rotation of lead screw 20 effecting linear travel of bar guide 22 as to the related rate. After sensing device 40 has emitted 240 pulses to counter 36 (equivalent to two-thirds of one rotation) by its first presetting, counter 36 will command a speed change of lead screw 20 by the appropriate operation of a relay or the like to cause command voltage circuit 37 to effect an output voltage having a potentiometer reading of x-4115 ohms, thereby causing a relative increase in the rate of linear movement of bar guide 22. Such voltage will be continued until sensing device 40 has emitted 3,228 additional pulses (or an accumulated total of 3,468) to counter 36 whereupon by the presetting of the latter a further speed change is commanded of lead screw 20 which will be relatively reduced as the output voltage of command voltage circuit will then having potentiometer reading of x-1395 ohms. This latter voltage will be continued until sensing device 40 has emitted 240 additional pulses (or an accumulated total of 3708) to counter 36 whereupon through the particular presetting the said counter will be moved to "off" position terminating the cycle. In timed sequence, mandrel 11 will be axially moved by its fluid motor so as to allow the now formed finished coil spring to be dropped into a suitable collector.

After the formed spring is ejected, mandrel 11 returns to initial position with bar guide 22 simultaneously being restored to its starting position; and with counter 36 resetting to "0" preparatory to the succeeding operation.

From the foregoing the commanding character of mandrel 11 is readily perceived as the first 240 pulses was equivalent to two-thirds of one turn of mandrel 11 and corresponded to the .660 inch lead for the first pitch. The succeeding 3,228 rotations of mandrel 11, or approximately 9 turns, was at such a higher rate as to allow for a constant pitch of 1.95 inches. After the formation of the latter pitch the succeeding and final 240 turns of mandrel 11 brought about the formation of the third pitch or second tangential end. It will thus be seen that the mandrel did rotate through a total 3708° of the equivalent of 10.3 rotations which corresponds to the total coils of the spring being formed.

Example II

There is to be formed a hot wound helical compression coil spring having the following characteristics:

Bar diameter	-----inches	.720
Inside diameter of the spring	-----do	4.000
Total coils	-----turns	8
Free length	-----inches	15

The spring is to have two square ends and is of the variable pitch character in that the longitudinal distances separating the coils between the square ends are of varying extent. From the foregoing characteristics, the hot built height of the spring was found to be 17.125 inches. As the spring has a variable rate, the pitches must necessarily be calculated and were found as follows:

1st pitch	-----	.000 inch for 2/3 turn.
2nd pitch	-----	.641 inch for 1/3 turn.
3rd pitch	-----	2.250 inches for 2 turns.
4th pitch	-----	2.750 inches for 2 turns.
5th pitch	-----	3.000 inches for 2 turns.
6th pitch	-----	.641 inch for 1/3 turn.
7th pitch	-----	.000 inch for 2/3 turn.

From chart 41 the operator determined the number of degrees of rotation of mandrel 11 requisite for each of the pitches of the spring being formed and thereby preset the counter 36. Similarly, by reference to said chart 41, the helic angle for the particular pitches is given and the corresponding volts are fed into the command voltage circuit. For the present spring, the "set-up" will be as follows:

Counter:	Degrees
1st pre-set	----- 240
2nd pre-set	----- 360
3rd pre-set	----- 1080
4th pre-set	----- 1800
5th pre-set	----- 2520
6th pre-set	----- 2640
7th pre-set	----- 2880
8th pre-set	----- Off

Command voltage circuit:	Ohms
1st potentiometer	----- x-0
2nd potentiometer	----- x-1350
3rd potentiometer	----- x-4750
4th potentiometer	----- x-5800
5th potentiometer	----- x-6325
6th potentiometer	----- x-1350
7th potentiometer	----- x-0
8th potentiometer	----- x-0

From the description of the operation of the system as given with respect to Example I hereinabove, the operation of the system for producing the present spring of variable pitch should be apparent. The square ends of this particular spring represent the first and second and 6th and 7th pitches respectively. After the mandrel will have made two-thirds of the turn, causing sensing device

40 to emit 240 pulses to counter 36, command voltage circuit 37 will have a change of output voltage which will remain in effect while mandrel 11 moves through a subsequent arc of 120° or one-third of a turn. At the termination of this limited arc counter 36 will effect a further change in the command voltage circuit so that as bar guide 22 is moved through succeeding increments of its path of travel it will do so at increasing rates, as is evident from the potentiometer readings for the command voltage circuit set-up. Thereupon the third, fourth, and fifth pitches will be formed, each of which is of progressively greater extent. After completion of the fifth pitch, bar guide 22 will be caused to travel at a relatively decreased rate for forming the sixth and seventh pitches, the potentiometer reading will be x-0 ohms. Whereafter, the system will go to "off" position preparatory to a repetition of the cycle.

The foregoing examples readily demonstrate the extreme versatility of the present invention and the substantially limitless potential thereof for producing compression coil springs of any constant pitch or of any variety of pitches, with the ends being tangential, pigtail, squared, or any other preferred shape, and of any desired cross section.

By the unique arrangement of components of the present machine, facile presetting of counter 36 and command voltage circuit 37, as above described, allow reliable programming of lead screw 20 for any given spring. The control of the various rates of linear travel of bar guide 22 assures of accurate control of the helic angle of the pitch as well as the length thereof. By the use of machine A there is obviated the necessity of a suitably grooved lead screw for each spring to be formed as has been considered critical prior to the present invention. The saving in time for production, as well as for set-up, by use of the present invention should indeed be manifest from the foregoing and the substantial saving by eliminating the need of a costly inventory of individual lead screws is obvious.

It should be understood that changes and modifications in the formation, construction, and arrangement and combination of the several parts of the coil spring winding machine may be made and substituted for these herein shown and described without departing from the nature and principle of our invention.

Having thus described our invention, what we desire to claim and obtain by Letters Patent is:

1. A coil spring forming machine comprising a mandrel for coiling of rod stock thereabout, means effecting rotation of said mandrel, a guide directing said rod stock to said mandrel, means causing said guide to travel in a linear path longitudinally of said mandrel, and means responsive to rotation of said mandrel effecting change of rate of travel of said guide at preselected points in its path of movement along said mandrel.

2. A coil spring forming machine as defined in claim 1 and further characterized by said means effecting rotation of said mandrel causing same to rotate at a constant predetermined rate.

3. A coil spring forming machine as defined in claim 2 and further characterized by said means for effecting change of rate of travel of said guide comprising a sensing device operatively connected to said mandrel and emitting signals responsive to angular displacement of said mandrel.

4. A coil spring forming machine as defined in claim 2 and further characterized by said means for causing said guide to travel in a linear path comprising a lead screw presented in axial parallel relation to said mandrel, means for rotating said lead screw, said guide being engaged to said lead screw for movement longitudinally thereof upon rotation of said screw, and said means for effecting change of rate of travel of said guide being operatively connected to said means for rotating said lead screw.

5. A coil spring forming machine as defined in claim 4 and further characterized by said guide being provided with depending directing fingers located laterally of said

9

mandrel and being spaced apart for reception therebetween of rod stock fed to said mandrel.

6. A coil spring forming machine as defined in claim 4 and further characterized by said means for rotating said lead screw comprising a servo motor and means interengaging said servo motor and said lead screw.

7. A coil spring forming machine as defined in claim 6 and further characterized by said means for effecting change of rate of travel of said guide comprising electric means for feeding preselected input voltages to said servo motor for effecting rotation of said lead screw at predetermined rates with corresponding rates of linear travel of said guide.

8. A coil spring forming machine as defined in claim 1 and further characterized by said means for effecting change of rate of travel of said guide comprising a sensing device operatively connected to said mandrel and emitting signals responsive to angular displacement of said mandrel.

9. A coil spring winding machine comprising a mandrel for coiling of rod stock thereabout, means for effecting rotation of said mandrel at a constant predetermined rate, a lead screw presented in axial parallel relation to said mandrel, a servo motor, means interengaging said servo motor and said lead screw for rotation of the latter, a guide for directing rod stock to said mandrel and being engaged on said lead screw for linear movement longitudinally thereof upon rotation of said lead screw, a sensing device connected to said mandrel for discharge of pulses responsive to angular displacement of said mandrel, and means for feeding said servo motor a preselected voltage upon discharge of a predetermined number of pulses by said sensing device for controlling the rate of linear travel of said guide.

10

10. A coil spring forming machine as defined in claim 9 and further characterized by said means for feeding a preselected voltage to said servo motor comprising a counter for receiving impulses from the sensing device, and a command voltage circuit for providing a preselected voltage output response to receipt of a signal from said counter, and means connecting said command voltage circuit and said servo motor.

11. A coil spring forming machine as defined in claim 9 and further characterized by said means for feeding a preselected voltage to said servo motor comprising an electric counter for receiving pulses from said sensing device for circuit closures at predetermined junctures, a command voltage circuit providing a preselected voltage output upon circuit closure by said counter, a servo amplifier connected to said command voltage circuit for receiving the output thereof and feeding same to the servo motor.

12. A coil spring forming machine as defined in claim 11 and further characterized by means for co-ordinating the rotation of said mandrel with energization of said counter for simultaneous cyclic operation.

References Cited

UNITED STATES PATENTS

2,373,427	4/1945	Stickney	72—138 X
2,868,268	1/1959	Lewis, et al.	72—138 X
2,959,367	11/1960	Kuba et al.	72—143 X
3,031,006	4/1962	Fokkinga	72—144 X
3,039,706	6/1962	Toth et al.	72—143 X

MILTON S. MEHR, Primary Examiner