

(19)
(12)

(KR)
(Y1)

(51) 。 Int. Cl.7
C09J 7/02

(45)
(11)
(24)

2004 06 10
20-0352401
2004 05 27

(21) 20-2004-0002945
(22) 2004 02 06

(73) 1 273-39

(72) 1 273-39

(74)

:

(54)

1 1 2

2

1

2

1 가

3 1 2

4 2 가

5

6

7 가

8

9

10 가

100, 200, 300 : 110, 210, 310 :

111, 211, 311 : 1 112, 212, 312 : 2

120, 220, 320 : 121, 221, 321 :

230 : 240, 340 :

2 , 1 1

10) (110)(210)(310) 1 , 가 (120)(220)(320) 1 가 (110)(210)(3 (

110)(210)(310) 1 (111)(211)(311) 2 (120)(220)(320) (121)(221)(321) (112)(212)(312)

(100) (300) (200)

(100) 1 4 (110)

(121) (110) (110) 가 1 (120) 2 (111)가

(120) (121) (100) 가 (120) (110) (110) 1 (111

가

111) (121) (120)가 1 (111)가 3 1 (

1 (11)가 1 (111) (120) 2 (112)가 (100)가 4

(230) (210)가 , (210) (200) 5 7

(221) (230) (110) 1 (211)가

(221) 5 1 (211) 2 (212) (210) (230)

(240)

(210) (220) (221) (200) 가 (210)

1 (211)가

(221) (220)가 1 (211)가 1 (211)

(210) (210)

(240)

1 (211)가 1 (211) (220) 2 (212) (240) 가

2 (220)가 7

(240)

(200)가

(300) 8 10

1 (311)가 (321) (310) (310)

(321) 1 8 (311) 2 (312) (310) 1 (311)가
(340)

20) (321) 가 (300) (320) (310) (310) (3
(311)가

(321) (320)가 1 (311)가 1 (311)

, 1 (311) (340)

(340) (320) 2 1 (312)가 (311)가 2 1 (312) (311)
(300)가

가 , 가

가 가

, 가
가

(57)

1.

1 1 2 ,

2.

1 ;

1 가 , 2 가

3.

1 ;

, ' 1 가 ,
2

3 4. ;

1 5. ;

1 , ' 2

5 6. ;

1 2 가

1

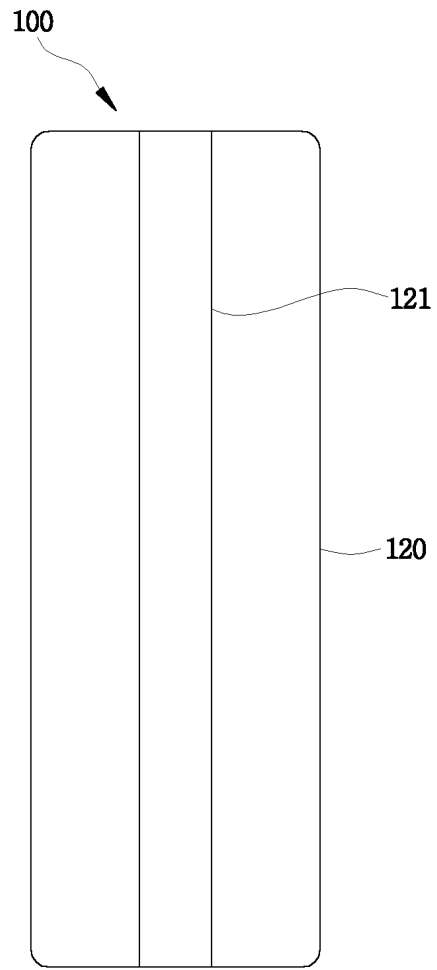

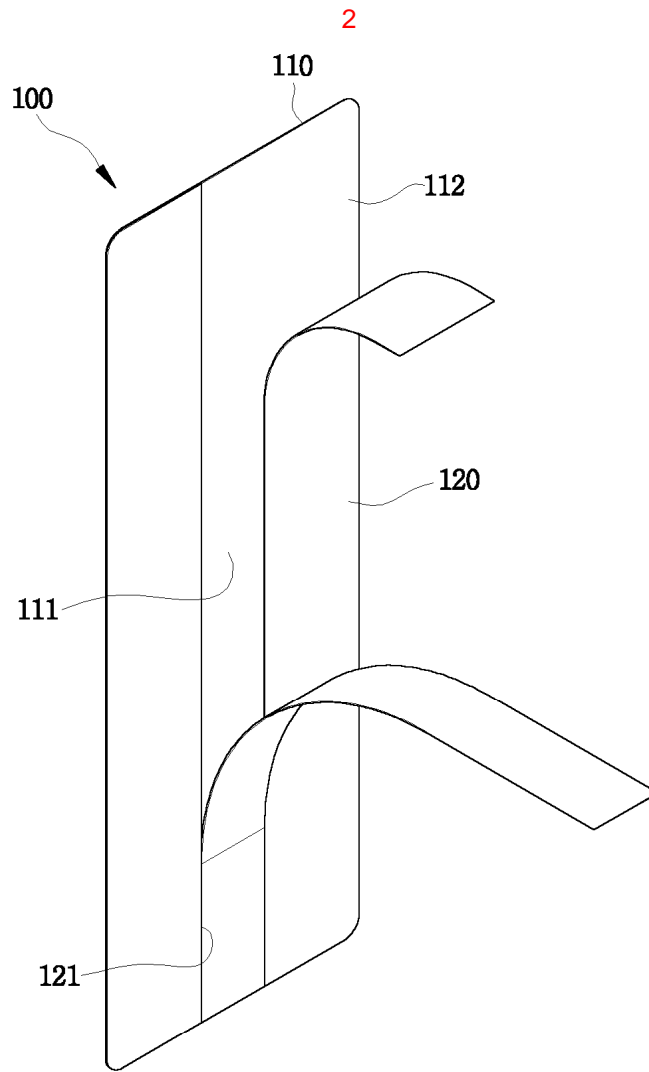

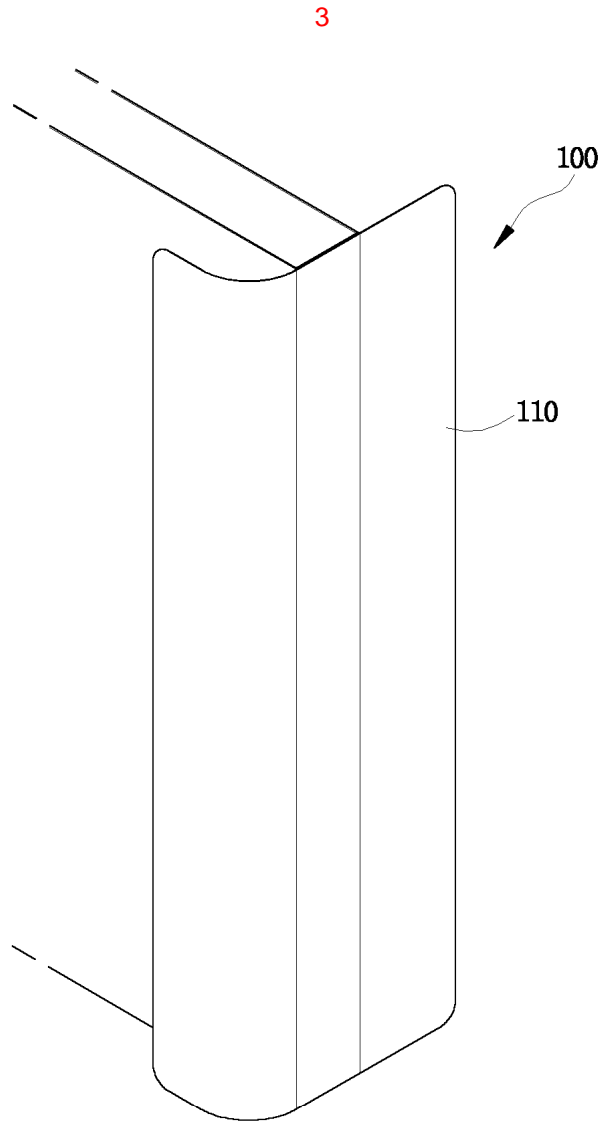

4

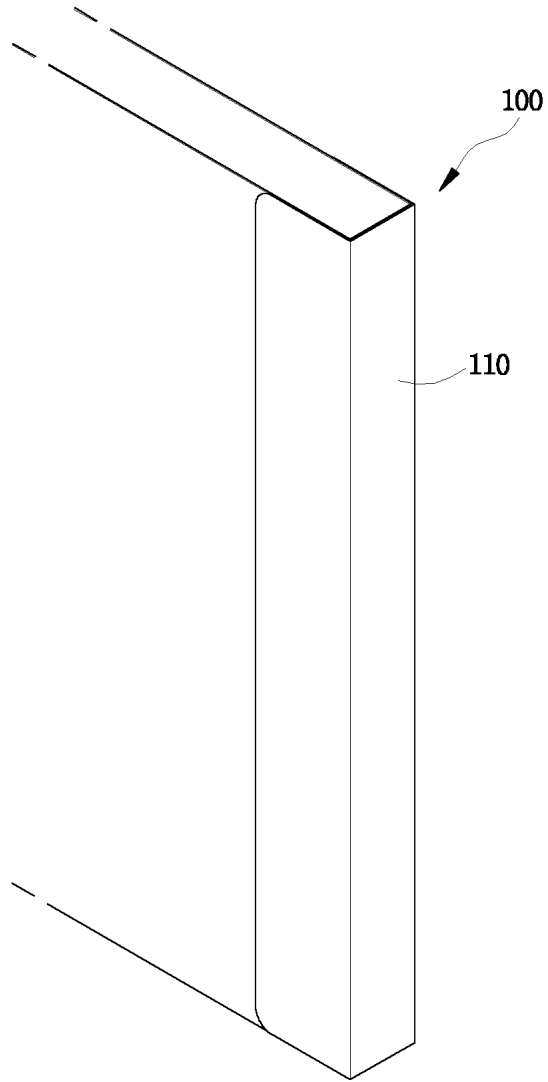

5

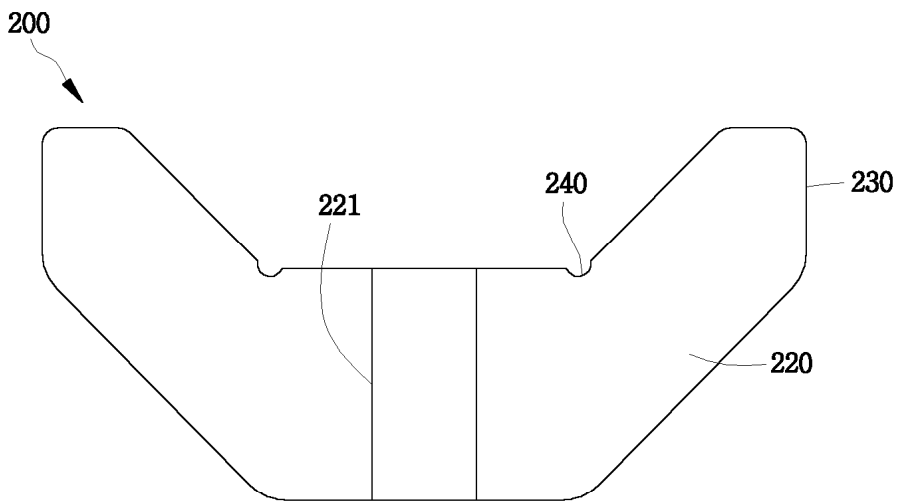

6

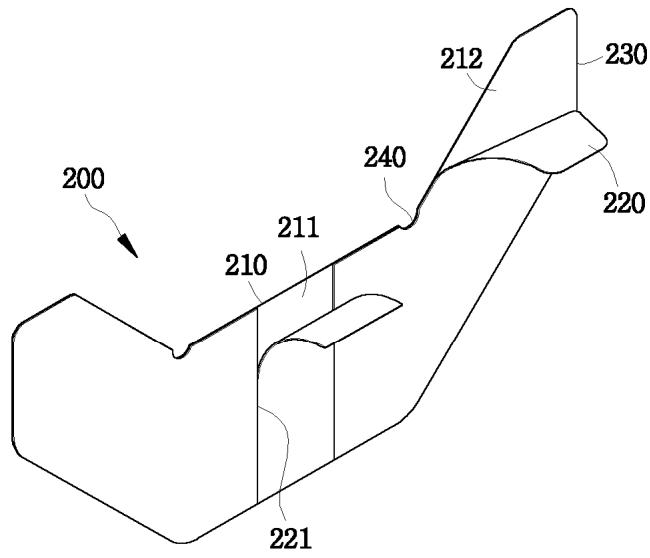

7

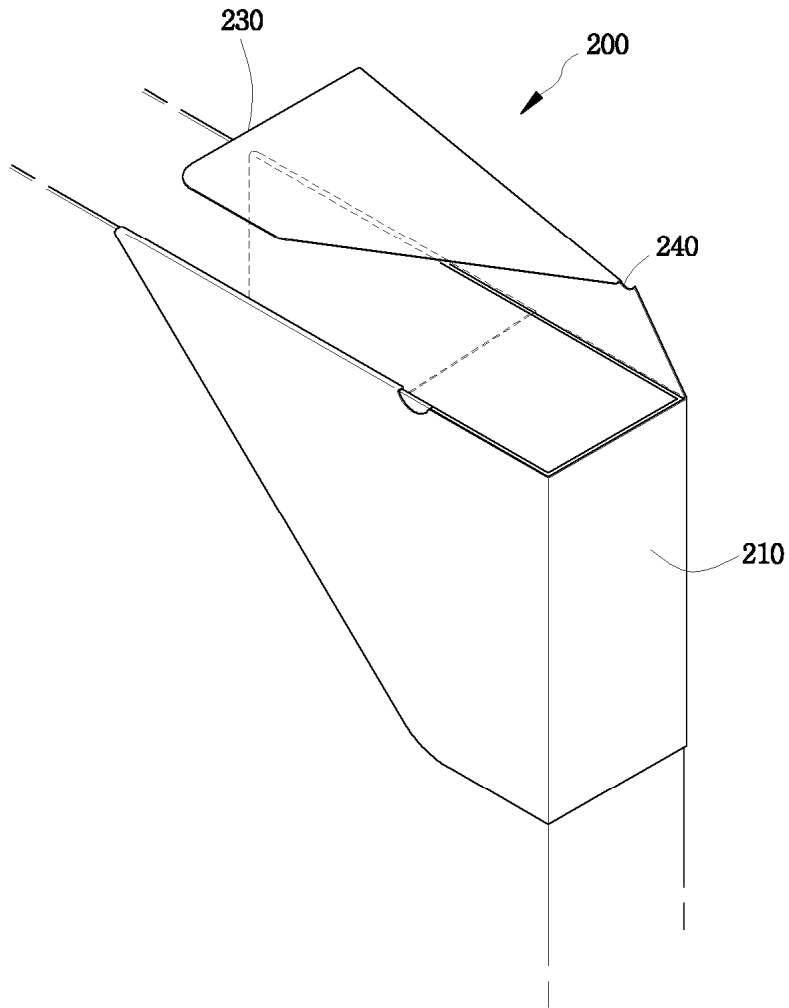

8

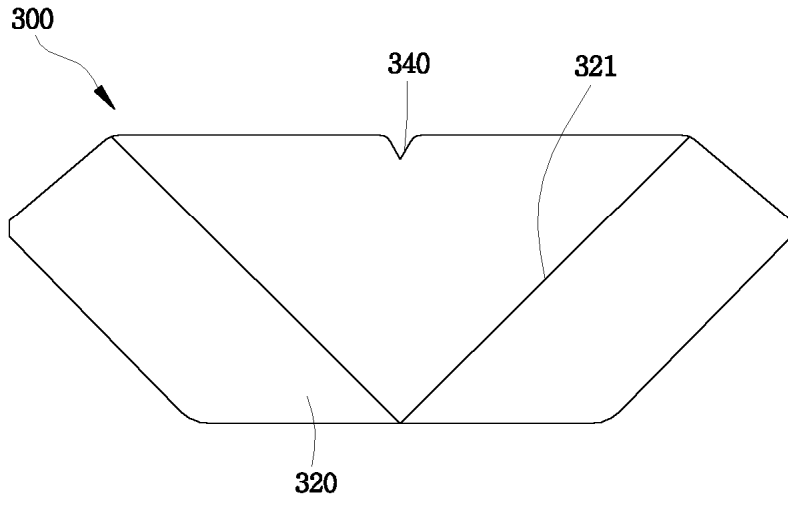

9

