

(19)  
(12)

(KR)  
(Y1)

(51) 。 Int. Cl.7  
E04F 19/06

(45)  
(11)  
(24)

2003 08 06  
20-0322177  
2003 07 24

(21) 20-2003-0014813  
(22) 2003 05 14

(73) 166-3

582-10

(72) 582-10

(74)

:

가 :

(54)

1

2

3

4

\*

\*

10 ; 11a, 11b ;

12 ; 20 ;

21 ; 22 ;

가

가  
가 가

가

가

4 가 가 4

(200), / (100), (100) (700) (200) (10

0) (300), (300) (300) (400)(500) (600)

1 3 (11a) , (11b) , (10) , (10) (11a)(11b)

(12) (21) ,

(22)가 (20)

(11a)(11b) (20) (21)

(11a)(11b) (21)가 (11a)(11b)

(20)가

(12) (10) 가

(10)

(100) (300) (10) ,

2 (10) (100) (300) 가 3 (10) ,

(100) (10) (600) , (10) (11a)(11b)

00) 가 (20) (21) (10) (10) (10) (20) (20) (6

가 가 가

(10) 가 가 (12)가

가 가

가

(57)

1.

(11a) , (12) (1

(11b) , (12) (1

0);

(10) (11a)(11b) (22) (20) (21) ,

1 2. (10) (11a)(11b) (20) (21)

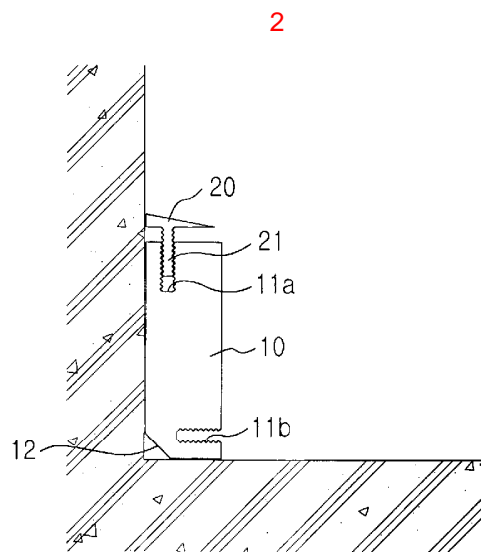
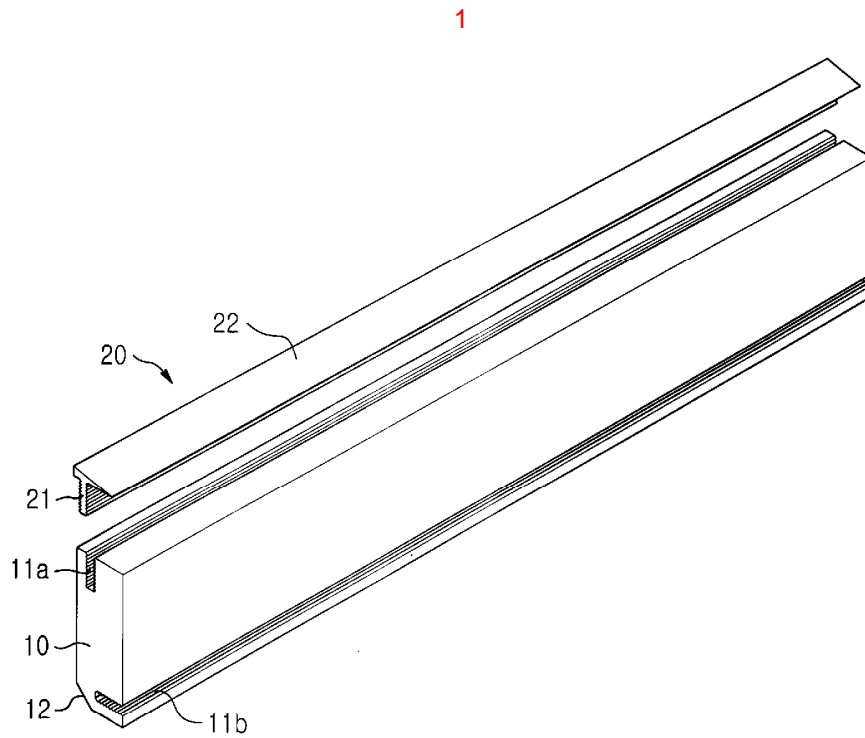

3

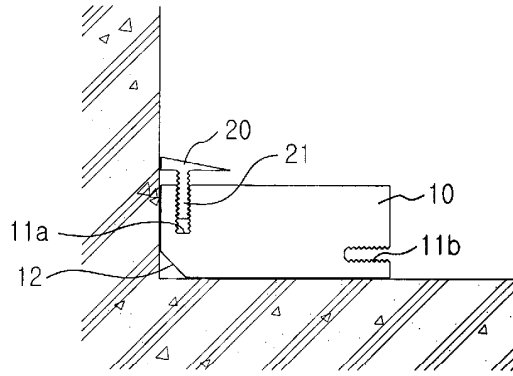

4

