

(19) World Intellectual Property Organization
International Bureau



(43) International Publication Date
30 December 2009 (30.12.2009)

(10) International Publication Number
WO 2009/158246 A1

- (51) **International Patent Classification:**
A61B 17/04 (2006.01) A61B 17/06 (2006.01)
- (21) **International Application Number:**
PCT/US2009/047599
- (22) **International Filing Date:**
17 June 2009 (17.06.2009)
- (25) **Filing Language:** English
- (26) **Publication Language:** English
- (30) **Priority Data:**
12/163,255 27 June 2008 (27.06.2008) US
- (71) **Applicant (for all designated States except US):**
ETHICON ENDO-SURGERY, INC. [US/US]; 4545
Creek Road, Cincinnati, OH 45242 (US).
- (72) **Inventors; and**
- (75) **Inventors/Applicants (for US only):** CARROLL, Kemp-
ton, K. [US/US]; 8388 Susanwoods Court, Cincinnati,
OH 45249 (US). SPIVEY, James, T. [US/US]; 542 Mis-
souri Avenue, Cincinnati, OH 45226 (US).
LINENKUGEL, Duane, A. [US/US]; 11999 Britesilks
Lane, Cincinnati, OH 45249 (US).
- (74) **Agents:** JOHNSON, Philip, S. et al.; ONE JOHNSON &
JOHNSON PLAZA, New Brunswick, NJ 08933 (US).
- (81) **Designated States (unless otherwise indicated, for every
kind of national protection available):** AE, AG, AL, AM,

AO, AT, AU, AZ, BA, BB, BG, BH, BR, BW, BY, BZ,
CA, CH, CL, CN, CO, CR, CU, CZ, DE, DK, DM, DO,
DZ, EC, EE, EG, ES, FI, GB, GD, GE, GH, GM, GT,
HN, HR, HU, ID, IL, IN, IS, JP, KE, KG, KM, KN, KP,
KR, KZ, LA, LC, LK, LR, LS, LT, LU, LY, MA, MD,
ME, MG, MK, MN, MW, MX, MY, MZ, NA, NG, NI,
NO, NZ, OM, PE, PG, PH, PL, PT, RO, RS, RU, SC, SD,
SE, SG, SK, SL, SM, ST, SV, SY, TJ, TM, TN, TR, TT,
TZ, UA, UG, US, UZ, VC, VN, ZA, ZM, ZW.

(84) **Designated States (unless otherwise indicated, for every
kind of regional protection available):** ARIPO (BW, GH,
GM, KE, LS, MW, MZ, NA, SD, SL, SZ, TZ, UG, ZM,
ZW), Eurasian (AM, AZ, BY, KG, KZ, MD, RU, TJ,
TM), European (AT, BE, BG, CH, CY, CZ, DE, DK, EE,
ES, FI, FR, GB, GR, HR, HU, IE, IS, IT, LT, LU, LV,
MC, MK, MT, NL, NO, PL, PT, RO, SE, SI, SK, TR),
OAPI (BF, BJ, CF, CG, CI, CM, GA, GN, GQ, GW, ML,
MR, NE, SN, TD, TG).

Declarations under Rule 4.17:

- as to applicant's entitlement to apply for and be granted a patent (Rule 4.17(ii))
- as to the applicant's entitlement to claim the priority of the earlier application (Rule 4.17(iii))

Published:

- with international search report (Art. 21(3))

(54) **Title:** SURGICAL SUTURE ARRANGEMENT

FIG. 1

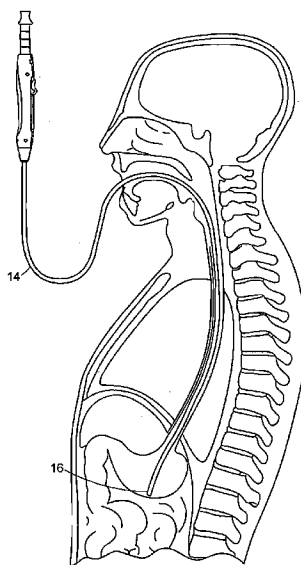

(57) **Abstract:** A surgical instrument may comprise a shaft having proximal and distal ends defining an axis therebetween. The shaft may be flexible and sized for insertion into the working channel of a flexible endoscope. The shaft may be configured to be used in conjunction with various suture anchor applicators. One suture anchor applicator may have a first tube with a first channel and a tissue penetrating tip. The first channel may be adapted to retain a second tube. The second tube may have a second channel and a blunt tip. The second channel may be adapted to retain at least one suture anchor and may include an exit port adapted for ejecting suture anchors. An alternative suture anchor applicator may comprise a first tube and a second tube with a tissue penetrating tip. The second channel is adapted to retain at least one suture anchor.



WO 2009/158246 A1

SURGICAL SUTURE ARRANGEMENT

BACKGROUND

[0001] The present application relates to surgical fasteners and instruments for approximating and fastening tissue and, more particularly, to suture anchors and associated instruments for endoscopically attaching sutures to tissue.

[0002] Access to the abdominal cavity may, from time to time, be required for diagnostic and therapeutic endeavors for a variety of medical and surgical diseases. Historically, abdominal access has required a formal laparotomy to provide adequate exposure. Such procedures, which require incisions to be made in the abdomen, are not particularly well-suited for patients that may have extensive abdominal scarring from previous procedures, those persons who are morbidly obese, those individuals with abdominal wall infection, and those patients with diminished abdominal wall integrity, such as patients with burns and skin grafting. Other patients simply do not want to have a scar if it can be avoided.

[0003] Minimally invasive procedures are desirable because such procedures can reduce pain and provide relatively quick recovery times as compared with conventional open medical procedures. Many minimally invasive procedures are performed with an endoscope (including without limitation laparoscopes). Such procedures permit a physician to position, manipulate, and view medical instruments and accessories inside the patient through a small access opening in the patient's body. Laparoscopy is a term used to describe such an "endosurgical" approach using an endoscope (often a rigid laparoscope). In this type of procedure, accessory devices are often inserted into a patient through trocars placed through the body wall. The trocar must pass through several layers of overlapping tissue/muscle before reaching the abdominal cavity.

[0004] Still less invasive treatments include those that are performed through insertion of an endoscope through a natural body orifice to a treatment region. Examples of this approach include, but are not limited to, cholecystectomy, appendectomy, cystoscopy, hysteroscopy, esophagogastroduodenoscopy, and colonoscopy. Many of these procedures employ the use of a flexible endoscope during the procedure. Flexible endoscopes often have a flexible, steerable articulating section near the distal end that can be controlled by the user by utilizing controls at the proximal end. Minimally invasive therapeutic procedures to treat diseased tissue by introducing medical instruments to a tissue treatment region through a natural opening of the patient are known as Natural Orifice Translumenal Endoscopic Surgery (NOTES)TM.

[0005] These minimally invasive surgical procedures have changed some of the major open surgical procedures such as gall bladder removal, or a cholecystectomy, to simple outpatient surgery. Consequently, the patient's recovery time has changed from weeks to days. These types of surgeries are often used for repairing defects or for the removal of diseased tissue or organs from areas of the body such as the abdominal cavity.

[0006] The working channel of a flexible endoscope typically has a diameter in the range of about 2.5 to about 4 millimeters. Current staplers and suturing devices cannot be easily redesigned to work through such small openings. In addition, performing procedures by way of the working channel does not easily permit using two instruments positioned at different angles with respect to the wound site in order to "pass and catch" a needle and apply sutures.

[0007] Various clips, suture fasteners and anchors have been developed such that physicians (e.g., gastroenterologists) may endoscopically close perforations in the gastrointestinal tract resulting from, for example, ulcers or polypectomy. One type of suture anchor is known as a "T-tag" fastener. The T-tag is a small metallic pin with a suture attached at the middle. The

physician may load the T-tag into the end of a cannulated needle of an applicator that may be inserted through the working channel of a flexible endoscope. The physician may push the needle into the tissue near the perforation and implant the T-tag into the tissue with the attached suture trailing through the working channel and out the proximal end of the endoscope. After two or more T-tags are attached to the tissue near the wound in this manner, the physician may pull the sutures to appose the tissue around the wound. The physician may then fasten the sutures together by applying a plurality of alternating, right and left overhand knots using a knot pushing device or by applying a knotting element or other type of fastener through the working channel of the endoscope.

[0008] An issue typically associated with current suture anchor applicators is the risk that nearby organs may be accidentally injured by the needle of the applicator. The physician normally cannot see anatomical structures on the distal side of the tissue layers when the needle is being pushed through the tissue layers. Therefore, there is a risk that adjacent organs may be accidentally injured by the penetrating needle.

[0009] There is a need for an improved suture anchor applicator that helps to prevent accidental injury to nearby anatomical structures during deployment of the anchor into tissue near a wound site.

[0010] The foregoing discussion is intended only to illustrate some of the shortcomings present in the field of the invention at the time, and should not be taken as a disavowal of claim scope.

FIGURES

[0011] The novel features of the various embodiments are set forth with particularity in the appended claims. The various embodiments, however, both as to organization and methods of

operation, may best be understood by reference to the following description, taken in conjunction with the accompanying drawings as follows.

[0012] **FIG. 1** is a drawing of a flexible, endoscopic portion of a gastroscope inserted into the upper gastrointestinal tract of a patient.

[0013] **FIG. 2** is a drawing of the distal portion of a suture anchor applicator extending from the distal end of the gastroscope while a first suture anchor is deployed into the stomach wall near a wound.

[0014] **FIG. 3** is a drawing of the applicator of FIG. 2 while a second suture anchor is deployed into the stomach wall on the opposing side of the wound.

[0015] **FIG. 4** is a drawing of the applicator of FIG. 2 while a pair of sutures of the first and second suture anchors are drawn together to appose the tissue on each side of the wound.

[0016] **FIG. 5** is a drawing of the pair of sutures of FIG. 4 fastened together with a knotting element, thereby holding the tissue in apposition.

[0017] **FIG. 6A** is a front view of one embodiment of a suture anchor applicator.

[0018] **FIG. 6B** is a side view of the suture anchor applicator of FIG. 6A.

[0019] **FIG. 6C** is a rear view of the suture anchor applicator of FIG. 6A.

[0020] **FIG. 7A** is a front view of the suture anchor applicator of FIG. 6A with a suture removed.

[0021] **FIG. 7B** is a side view of the suture anchor applicator of FIG. 6B with the suture removed.

[0022] **FIG. 8A** is a front view of the suture anchor applicator of FIG. 7A with a needle portion removed.

[0023] **FIG. 8B** is a side view of the suture anchor applicator of FIG. 7B with the needle portion removed.

[0024] **FIG. 9A** is a front view of the suture anchor applicator of FIG. 8A with a blunt tip portion removed.

[0025] **FIG. 9B** is a side view of the suture anchor applicator of FIG. 8B with the blunt tip portion removed.

[0026] **FIG. 9C** is a side view of a suture anchor with a suture attached to the suture anchor.

[0027] **FIG. 9D** is a front view of the suture anchor of FIG. 9C.

[0028] **FIGS. 10A-10E** illustrate a method of attaching a suture anchor to the tissue of patient using the suture anchor applicator of FIG. 6A.

[0029] **FIG. 11A** is a side view of an alternative embodiment of a suture anchor applicator.

[0030] **FIG. 11B** is a front view of the suture anchor applicator of FIG. 11A.

[0031] **FIG. 12A** is a side view of the suture anchor applicator of FIG. 11A with an outer sheath removed.

[0032] **FIG. 12B** is a front view of the suture anchor applicator of FIG. 11B with the outer sheath removed.

[0033] **FIG. 12C** is a rear view of the suture anchor applicator of FIG. 11B with the outer sheath removed.

[0034] **FIG. 13A** is a side view of the suture anchor applicator of FIG. 12A with a needle portion removed.

[0035] **FIG. 13B** is a front view of the suture anchor applicator of FIG. 12B with the needle portion removed.

[0036] **FIGS. 14A-14E** illustrate a method of attaching a suture anchor to the tissue of patient using the suture anchor applicator of FIG. 11A.

DESCRIPTION

[0037] Before explaining the various embodiments in detail, it should be noted that the embodiments are not limited in their application or use to the details of construction and arrangement of parts illustrated in the accompanying drawings and description. The illustrative embodiments may be implemented or incorporated in other embodiments, variations and modifications, and may be practiced or carried out in various ways. For example, the suture anchor applicators and the suture anchor configurations disclosed below are illustrative only and not meant to limit the scope or application thereof. Furthermore, unless otherwise indicated, the terms and expressions employed herein have been chosen for the purpose of describing the illustrative embodiments for the convenience of the reader and are not to limit the scope thereof.

[0038] **FIG. 1** illustrates a flexible endoscopic portion 16 of a gastroscope 14 inserted into the upper gastrointestinal tract of a patient. **FIGS. 2, 3, 4 and 5** illustrate a procedure for repairing a wound such as a gastric bleeding ulcer in the stomach wall of the patient via the working channel of gastroscope 14. **FIG. 2** is a drawing of the distal portion of a suture anchor applicator extending from the distal end of the gastroscope while a first suture anchor is deployed into the stomach wall near a wound. **FIG. 3** is a drawing of the applicator of FIG. 2 while a second suture anchor is deployed into the stomach wall on the opposing side of the wound. As shown in FIG. 2, the physician (e.g., gastroenterologist) inserts a suture anchor applicator 18 through gastroscope 14 and penetrates a cannulated needle 19 through the stomach wall near the diseased area or wound. Needle 19 contains at least one suture anchor such that, as shown in FIG. 3, the

physician may deploy a first suture anchor 20 attached to a first suture 24 to one side of the wound and a second suture anchor 22 attached to a second suture 26 to the opposite side of the wound. First and second suture anchors 20, 22 may be conventional "T-tag" fasteners or any of the suture anchor embodiments described herein or their equivalents.

[0039] **FIG. 4** is a drawing of the applicator of FIG. 2 while a pair of sutures of the first and second suture anchors are drawn together to appose the tissue on each side of the wound. **FIG. 5** is a drawing of the pair of sutures of FIG. 4 fastened together with a knotting element, thereby holding the tissue in apposition. The free ends of first and second sutures 24, 26 may extend through the proximal end of gastroscope 14 such that, as shown in FIG. 4, the physician may draw the first and second sutures 24, 26 together to appose the tissue around the wound. The physician may then fasten the first and second sutures 24, 26 together by, for example, applying a plurality of alternating, right and left overhand knots using a knot pushing device (not shown) or by applying a knotting element 28 or other type of fastener, as shown in FIG. 5, by way of the working channel of gastroscope 14. Excess suture may be trimmed near the knot using an endoscopic cutting instrument.

[0040] When using T-tag fasteners with the technique shown in FIGS. 2-5, there are necessary conditions for the T-tag fasteners to become securely attached to the tissue. For example, it is important that the T-tag fastener reorient with respect to the suture as previously described such that the T-tag may not be easily pulled through the tissue. If the T-tag is positioned within the tissue rather than completely through the tissue into a body cavity, the T-tag still must reorient to some degree such that the suture is securely attached to the tissue.

[0041] Although the size of the cannulated needle 19 shown in FIG. 2 may vary, it may have an inner diameter of less than one millimeter. Consequently, suture anchor 22 must be very

small to be loaded inside of needle 19, yet once deployed into tissue, must be sufficiently broad to resist pull-out from tissue such that considerable tension may be applied to the sutures to draw together the tissue. Therefore, it may be desirable for suture anchor 22 to expand once deployed from the applicator and/or to include features to help secure anchor 22 to the tissue. In addition, it may be desirable for suture anchor 22 to remain securely in the loaded position within applicator 18 prior to deployment into tissue to avoid the time-consuming steps of withdrawing, reloading and reinserting the applicator.

[0042] Recently, a number of medical devices have been developed that provide an auxiliary passageway along the outside of the endoscope. One example of a medical apparatus that provides an auxiliary endoscopic passageway may be found in U.S. Patent Application Serial Number 10/440,957 (published as U.S. Patent Pub. No. 2004/0230095), filed May 12, 2003, and assigned to Ethicon Endo-Surgery, Inc. The auxiliary passageway may be used, perhaps in combination with the working channel of the endoscope, for several purposes, such as to insert a suture anchor applicator for access to an internal wound site. It should be understood, therefore, that descriptions herein referring to the working channel of the endoscope also include using such an auxiliary passageway.

[0043] A physician may fully penetrate the needle of a suture anchor applicator through tissue layers of an organ in order to deploy the suture anchor on the distal side of the tissue layers. The physician normally cannot see anatomical structures on the distal side of the tissue layers through the endoscope and therefore may accidentally injure nearby organs with the penetrating needle. An aspect of a suture anchor applicator, a veress-type needle configuration, is provided to help prevent such accidental injury.

[0044] Newer procedures have developed which may even be less invasive than the laparoscopic procedures used in earlier surgical procedures. Many of these procedures employ the use of a flexible endoscope during the procedure. Flexible endoscopes often have a flexible, steerable articulating section near the distal end that can be controlled by the user by utilizing controls at the proximal end. Minimally invasive therapeutic procedures to treat diseased tissue by introducing medical instruments to a tissue treatment region through a natural opening of the patient are known as Natural Orifice Translumenal Endoscopic Surgery (NOTES)TM. NOTESTM is a surgical technique whereby operations can be performed trans-orally (as depicted in FIG.1), trans-anally, and/or trans-vaginally.

[0045] Certain embodiments will now be described to provide an overall understanding of the principles of the structure, function, manufacture, and use of the devices and methods disclosed herein. One or more examples of these embodiments are illustrated in the accompanying drawings. Those of ordinary skill in the art will understand that the devices and methods specifically described herein and illustrated in the accompanying drawings are non-limiting embodiments and that the scope of the various embodiments is defined solely by the claims. The features illustrated or described in connection with one embodiment may be combined with the features of other embodiments. Such modifications and variations are intended to be included within the scope of the claims.

[0046] It will be appreciated that the terms “proximal” and “distal” are used herein with reference to a clinician gripping the surgical instrument. Thus, the suture anchor applicators are distal with respect to the handle assemblies of the surgical instrument. It will be further appreciated that, for convenience and clarity, spatial terms such as “top” and “bottom” also are used herein with respect to the clinician gripping the handle. However, surgical instruments are

used in many orientations and positions, and these terms are not intended to be limiting and absolute.

[0047] **FIG. 6A** is a front view of one embodiment of a suture anchor applicator 100. **FIG. 6B** is a side view of the suture anchor applicator 100. **FIG. 6C** is a rear view of the suture anchor applicator 100. As shown in FIGS. 6A-6C, the suture anchor applicator 100 may comprise a needle portion 102 and a blunt tip portion 104. The suture anchor applicator 100 is shown in FIGS. 6A-6C in a shielding, or non-compressed, position with the blunt tip portion 102 extending distally past the needle portion 104. This may allow the blunt tip portion 104 to contact tissue prior to the needle portion 102 contacting the same tissue. In operation, the suture anchor applicator 100 may be pressed against a portion of tissue such that the blunt tip portion 104 contacts the tissue. As the force applied to the suture anchor applicator 100 by the tissue is increased, the blunt tip portion 104 may slidably retract into the needle portion 102, as shown by arrow 126, until the needle portion 102 punctures the tissue and removes the force placed on the suture anchor applicator 100. Once the needle portion 102 has punctured the tissue, the blunt tip portion 104 may return to the shielding position where the blunt tip portion 104 extends past the needle portion 102.

[0048] In various embodiments, the needle portion 102 may be formed of a tube which may have a channel extending from a proximal end 106 of the needle portion 102 to a distal end 108 of the needle portion 102. The distal end 108 of the needle portion 102 may comprise a tissue penetrating tip 110. The needle portion 102 may be ground to form the tissue penetrating tip 110. The needle portion 102 may be fabricated from stainless steel hypodermic tubing or any other suitable material which may include metal and/or plastic. Alternatively, the needle portion 102 may be formed from an alternate type of metallic or polymeric tube and attached to a

cannulated needle (not shown), such as by bolting, screwing, welding, crimping, gluing or any other suitable method. The needle portion 102 may have a diameter in the range of 10-35 gage. For example, the needle portion 102 may be formed from 19 gage stainless steel hypodermic tubing having an outer diameter of approximately 0.043 inches (1.09 millimeters) and a wall thickness of approximately 0.003 inches (.076 millimeters). At least a portion of the needle portion 102 may be configured to slidably retain the blunt tip portion 104.

[0049] In various embodiments, the blunt tip portion 104 may be formed of a tube which may have a channel extending from a proximal end 112 of the blunt tip portion 104 (see FIG. 8A) to a distal end 114 of the blunt tip portion 104. The distal end 114 of the blunt tip portion 104 may comprise a blunt tip 116. The channel of the blunt tip portion 104 may be configured to retain at least one suture anchor 118 (see FIG. 9A). The blunt tip portion 104 may include an exit port 120 which may adapted for ejecting the at least one suture anchor 118. A suture 122 may be connected to the suture anchor 118 and may exit the exit port 120 proximally towards a proximal handle of a surgical device, for example, the gastroscope of FIG. 1. The blunt tip portion 104 may be fabricated from metal, plastic, or any other suitable material for such applications.

[0050] **FIG. 7A** is a front view of the suture anchor applicator 100 with the suture 122 removed. **FIG. 7B** is a side view of the suture anchor applicator 100 with the suture 122 removed. As shown in FIG. 7A, the needle portion 102 may contain a slot 124 near the distal end 108 of the needle portion 102. The slot 124 may be configured to allow a suture 122 to run from the exit port 120 of the blunt tip portion 104 towards the proximal end of the surgical instrument. This configuration may prevent the suture 122 from being cut when the blunt tip portion 104 is slidably retracted into the needle portion 102. As discussed above, the blunt tip portion 104 may be slidably retracted into the needle portion 102 during a suture anchor

placement procedure. The exit port 120 may be located on one side of the blunt tip portion 104 and may be centered along an axis "L." The slot 124 may be located on one side of the needle portion 102 and may also be centered along the axis L. The centers of the exit port 120 and the slot 124 may be substantially aligned along axis L. The suture 122 may exit the exit port 120 on the proximal end 128 of the exit port 120 and may be at least partially contained within the slot 124 during the blunt tip portion's 104 retraction.

[0051] **FIG. 8A** is a front view of the suture anchor applicator 100 with the needle portion 102 removed. **FIG. 8B** is a side view of the suture anchor applicator 100 with the needle portion 102 removed. As shown in FIGS. 8A-8B, the blunt tip portion 104 may be at least partially retained on a tag pusher 130. The tag pusher 130 may extend from a distal end 136 of a stylet pusher 132 through at least a portion of the channel of the blunt tip portion 104. The tag pusher 130 may be fabricated to have a cross-section which is circular, rectangular, square, or any other suitable shape. The tag pusher 130 may have a cross-section which corresponds to the interior cross-section of the blunt tip portion 104. The tag pusher 130 may be fabricated from metal, plastic, or any other suitable material. The stylet pusher 132 may be a hollow member and the tag pusher may at least partially extend into the stylet pusher 132. The stylet pusher 132 may be formed of a tube which may have an inner cross-section which corresponds to the cross-section of the tag pusher 130. For example, if the tag pusher has a circular cross-section, then the interior cross-section of the stylet pusher 132 may also have a circular cross-section. The stylet pusher 132 may be fabricated from metal, plastic, or any other suitable material for such applications. In various embodiments, a compression member 134 may be retained between the proximal end 112 of the blunt tip portion 104 and the distal end 136 of the stylet pusher 132. The tag pusher

130 may pass through the compression member 134. The compression member 134 may be a coil spring (as shown in FIGS. 8A-8B), a leaf spring, or any other suitable compression member.

[0052] In various embodiments, the compression member 134 may apply a predetermined compression force to bias the blunt tip portion 104 to the shielding position. As discussed above, the blunt tip portion 104 can move to the compressed, or retracted, position when the blunt tip portion 104 is pushed against tissue with a force greater than the compression force, such that the needle portion 102 can penetrate tissue. Once the needle portion 102 has penetrated through the tissue, the blunt tip portion 104 can immediately extend to the shielding position to help prevent accidental injury to nearby anatomical structures. In addition, once the needle portion 102 has penetrated the tissue, the tag pusher 130 may be fired and a suture anchor 118 may be ejected from the exit port 120. The firing of the tag pusher 130 may be accomplished through the use of an actuator (not shown) located on the handle of the surgical instrument. A physician, or any other operator of the surgical instrument, may operate the actuator to fire the tag pusher 130 to deploy the suture anchor 118 into the tissue, thereby attaching suture 122 to the tissue. When the tag pusher 130 is fired, the tag pusher 130 translates distally inside of the blunt tip portion 104 and ejects a suture anchor 118 from the exit port 120. The compression member 134 may be fabricated from metal, plastic, or any other suitable material for such applications.

[0053] **FIG. 9A** is a front view of the suture anchor applicator 100 with a blunt tip portion 104 removed. **FIG. 9B** is a side view of the suture anchor applicator 100 with the blunt tip portion 104 removed. **FIG. 9C** is a side view of the suture anchor 118 with the suture 122 attached to the suture anchor 118. **FIG. 9D** is a front view of the suture anchor 118. As shown in FIGS. 9A-9B, the suture anchor 118 may be located within the blunt tip portion 104. The suture anchor 118 may be located at the distal end 138 of the tag pusher 130. As shown in FIG. 9C, the suture

122 may be attached to the suture anchor 118 at or near the center attachment portion 140 of the suture anchor 118. The suture 122 may be attached to the suture anchor 118 through fusing, gluing, knotting or any other suitable attachment method.

[0054] FIGS. 10A-10E illustrate a method of attaching a suture anchor to 118 the tissue 140 of a patient using the suture anchor applicator 100. As shown in FIG. 10A, the blunt tip portion of the suture anchor applicator 100 may be placed against tissue 140 of a patient. In various embodiments, the blunt tip portion 104 may extend past the distal end of the needle portion 102 in the shielding position. As the suture anchor applicator 100 is pushed against the tissue 140, the blunt tip portion 104 contacts the tissue 140 before the needle portion 102. As the blunt tip portion 104 is pushed against the tissue 140, the blunt tip portion 104 may retract into the needle portion 102. As shown in FIG. 10B, the blunt tip portion 104 may be substantially within the needle portion 102 as the needle portion 102 penetrates the tissue 140. As shown in FIG. 10C, once the needle portion 102 has penetrated the tissue 140, the blunt tip portion 104 may be sprung from the needle portion 102 due to the interaction of the blunt tip portion 104 and the compression member 134. As shown in FIG. 10D, an operator of the surgical instrument may operate the actuator to fire the tag pusher 130 (not shown) to deploy the suture anchor 118 to the distal side of the tissue 140. As shown in FIG. 10E, the needle portion 102 and the blunt tip portion 104 may be removed from the tissue 140. The suture anchor 118 may be pulled securely against the distal side of the tissue 140 as the needle portion 102 and the blunt tip portion 104 are removed. The above process may be repeated to attach a second suture anchor 118 to the distal side of the tissue 140. Once the second suture anchor 118 has been placed on the distal side of the tissue 140, the suture 122 may be tightened through the use of a knotting element (not shown) or any other suitable element used for tightening sutures.

[0055] **FIG. 11A** is a side view of an alternative embodiment of a suture anchor applicator 200. **FIG. 11B** is a front view of the suture anchor applicator 200. As shown in FIGS. 11A-11B, the suture anchor applicator 200 may comprise an outer sheath 201. The outer sheath 201 may be formed of a tube which may have a channel extending from the proximal end of the outer sheath 201 to the distal end of the outer sheath 201. The outer sheath 201 may be formed from an extruded polymer, a helically wound metallic wire or from any other suitable materials well-known in the art. A suture 222 may extend proximally from the distal end of the outer sheath 201 along the outside of the outer sheath 201 towards the proximal end of the surgical instrument.

[0056] **FIG. 12A** is a side view of the suture anchor applicator 200 with the outer sheath 201 removed. **FIG. 12B** is a front view of the suture anchor applicator 200 with the outer sheath 201 removed. **FIG. 12C** is a rear view of the suture anchor applicator 200 with the outer sheath 201 removed. As shown in FIGS. 12A-12C, the suture anchor applicator 200 may further comprise a needle portion 202, and a suture anchor 218. At least a portion of the outer sheath 201 may be adapted to slidably retain the needle portion 202. In one embodiment, the tip 216 of the suture anchor 218 may have a substantially flat shape. In other embodiments (not shown), the tip 216 have a blunt shape or other suitable shape.

[0057] The needle portion 202 and the suture anchor 218 are shown in FIGS. 12A-12C in a shielding position with the tip 216 of the suture anchor 218 extending distally past the needle portion 204. This may allow the tip 216 of the suture anchor 218 to contact tissue prior to the needle portion 102 contacting the same tissue. In operation, the suture anchor 218 may be pressed against a portion of tissue such that the tip 216 of the suture anchor 218 contacts the tissue. As the force applied to the tip 216 of the suture anchor 218 by the tissue is increased, the

suture anchor 218 may slidably retract into the needle portion 202, as shown by arrow 226, until the needle portion 202 punctures the tissue and removes the force placed on the suture anchor 218. Once the needle portion 202 has punctured the tissue, the suture anchor may spring past the shielding position, eject from the needle portion 202 and be deployed on the distal side of the tissue.

[0058] In various embodiments, the needle portion 202 may be formed of a tube which may have a channel extending from a proximal end 206 of the needle portion 202 to a distal end 208 of the needle portion 202. The distal end 208 of the needle portion 202 may comprise a tissue penetrating tip 210. The needle portion 202 may be ground to form the tissue penetrating tip 210. The needle portion 202 may be fabricated from stainless steel hypodermic tubing or any other suitable material which may include metal and/or plastic. Alternatively, the needle portion 202 may be formed from an alternate type of metallic or polymeric tube and attached to a cannulated needle (not shown), such as by bolting, screwing, welding, crimping, gluing or any other suitable method. The needle portion 202 may have a diameter in the range of 10-35 gage. For example, the needle portion 202 may be formed from 19 gage stainless steel hypodermic tubing having an outer diameter of approximately 0.043 inches (1.09 millimeters) and a wall thickness of approximately 0.003 inches (.076 millimeters). At least a portion of the needle portion 102 may be configured to slidably retain the suture anchor 218.

[0059] **FIG. 13A** is a side view of the suture anchor applicator 200 with the needle portion 202 removed. **FIG. 13B** is a front view of the suture anchor applicator 200 with the needle portion 202 removed. As shown in FIGS. 13A-13B, the suture anchor 218 may be at least partially retained on a tag pusher 230. The tag pusher 230 may extend through at least a portion of the channel of the needle portion 202. The tag pusher 230 may comprise a first member 231, a

second member 232, and a compression member 234. In various embodiments, the compression member 234 may be retained between the first member 231 and the second member 232. The first member 231 and the second member may be connected by the compression member 234. The compression member 234 may be attached to the first member 231 and/or the second member 232 through any attachment means which may include bolting, screwing, welding, gluing, fusing, or any other suitable method. The compression member 234 may be a coil spring (as shown in FIGS. 13A-13B), a leaf spring, or any other suitable compression member. The first member 231 and/or the second member 232 may be fabricated to have a cross-section which is circular, rectangular, square, or any other suitable shape. The first member 231 and/or the second member may have a cross-section which corresponds to the interior cross-section of the needle portion 202. The first member 231 and/or the second member may be fabricated from metal, plastic, or any other suitable material for such applications. The compression member 234 may be fabricated from metal, plastic, or any other suitable material for such applications.

[0060] In various embodiments, the compression member 234 may apply a predetermined compression force to bias the suture anchor 218 to the shielding position. As discussed above, the suture anchor 218 can move to the compressed, or retracted, position when the suture anchor 218 is pushed against tissue with a force greater than the compression force, such that the needle portion 202 can penetrate tissue. Once the needle portion 202 has penetrated through the tissue, the suture anchor 218 may spring forward and be ejected from the distal end 208 of the needle portion 202 on the distal side of the tissue. The ejection of the suture anchor 218 may be accomplished due to the interaction of the first member 231 and the compression member 234 with the suture anchor. The suture anchor 218 may be press fit into the needle portion 202 to be at least partially retained in the needle portion 202. The springing action of the suture anchor

218 may be sufficient to overcome forces created by the press fit and eject the suture anchor 218 from the needle portion 202.

[0061] FIGS. 14A-14E illustrate a method of attaching a suture anchor 218 to the tissue of a patient using the suture anchor applicator 200. As shown in FIG. 14A, the outer sheath 201 of the suture anchor applicator 200 may be placed against tissue 240 of a patient. The outer sheath 201 may be retracted once it is placed near the tissue 240 to be sutured. For clarity, the outer sheath 210 has been removed from FIGS. 14B-14E. As shown in FIG. 14B, the suture anchor 218 may extend past the distal end of the needle portion 202 in the shielding position. As the suture anchor applicator 200 is pushed against the tissue 240, the suture anchor 218 contacts the tissue 240 before the needle portion 202. As the suture anchor 218 is pushed against the tissue 240, the suture anchor 218 may retract into the needle portion 202. As shown in FIG. 14C, the suture anchor 218 may be substantially within the needle portion 202 as the needle portion 202 penetrates the tissue 240. As shown in FIG. 14D, once the needle portion 202 has penetrated the tissue 240, the suture anchor 218 may be sprung from the needle portion 202 due to the interaction of the suture anchor 218, the first member 231, and the compression member 234 and be deployed on the distal side of the tissue 240. As shown in FIG. 14E, the needle portion 202 may be removed from the tissue 240. The suture anchor 218 may be pulled securely against the distal side of the tissue 240 as the needle portion 202 is removed. The above process may be repeated to attach a second suture anchor 218 to the distal side of the tissue 240. Once the second suture anchor 218 has been placed on the distal side of the tissue 240, the suture 222 may be tightened through the use of a knotting element (not shown) or any other suitable element used for tightening sutures.

[0062] FIG. 15 is a perspective view of an embodiment of a surgical instrument, generally designated 300, that is adapted to help prevent injury to nearby anatomical structures while deploying a suture anchor. The surgical instrument 300 may include an elongated shaft 304 attached to a handle 302. The shaft 304 may have a distal end 320 and a proximal end 322 defining an axis therebetween. The shaft 304 may be flexible and may be sized for insertion into the working channel of a flexible endoscope. The surgical instrument 300 may be used in conjunction with either of the disclosed suture anchor applicators 100, 200 (not shown). The suture anchor applicators 100, 200 may be located at the distal end 320 of the shaft 304. The suture anchor applicators 100, 200 may be attached to the distal end 320 through any attachment means which may include bolting, screwing, welding, gluing, fusing, or any other suitable method. The surgical instrument 300 is described next as it may be adapted for use with suture anchors 118, 218, although the surgical instrument 300 may also be adapted for use with many types of suture anchors, including any of the suture anchor aspects described herein and their equivalents. As may be seen in FIG. 15, the handle 302 may include an actuator 312. A physician may operate the actuator 312 to deploy a suture anchor into the tissue, thereby attaching a suture to the tissue.

[0063] The devices disclosed herein can be designed to be disposed of after a single use, or they can be designed to be used multiple times. In either case, however, the device can be reconditioned for reuse after at least one use. Reconditioning can include any combination of the steps of disassembly of the device, followed by cleaning or replacement of particular pieces, and subsequent reassembly. In particular, the device can be disassembled, and any number of the particular pieces or parts of the device can be selectively replaced or removed in any combination. Upon cleaning and/or replacement of particular parts, the device can be

reassembled for subsequent use either at a reconditioning facility, or by a surgical team immediately prior to a surgical procedure. Those skilled in the art will appreciate that reconditioning of a device can utilize a variety of techniques for disassembly, cleaning/replacement, and reassembly. Use of such techniques, and the resulting reconditioned device, are all within the scope of the present application.

[0064] Preferably, the various embodiments described herein will be processed before surgery. First, a new or used instrument is obtained and if necessary cleaned. The instrument can then be sterilized. In one sterilization technique, the instrument is placed in a closed and sealed container, such as a plastic or TYVEK® bag. The container and instrument are then placed in a field of radiation that can penetrate the container, such as gamma radiation, x-rays, or high-energy electrons. The radiation kills bacteria on the instrument and in the container. The sterilized instrument can then be stored in the sterile container. The sealed container keeps the instrument sterile until it is opened in the medical facility.

[0065] It is preferred that the device is sterilized. This can be done by any number of ways known to those skilled in the art including beta or gamma radiation, ethylene oxide, steam.

[0066] Although various embodiments have been described herein, many modifications and variations to those embodiments may be implemented. For example, different types of specimen retrieval bags may be employed. In addition, combinations of the described embodiments may be used. For example, the specimen retrieval bag may comprise a fused portion at the proximal end and an open portion at the distal end. Also, where materials are disclosed for certain components, other materials may be used. The foregoing description and following claims are intended to cover all such modification and variations.

[0067] Any patent, publication, or other disclosure material, in whole or in part, that is said to be incorporated by reference herein is incorporated herein only to the extent that the incorporated materials does not conflict with existing definitions, statements, or other disclosure material set forth in this disclosure. As such, and to the extent necessary, the disclosure as explicitly set forth herein supersedes any conflicting material incorporated herein by reference. Any material, or portion thereof, that is said to be incorporated by reference herein, but which conflicts with existing definitions, statements, or other disclosure material set forth herein will only be incorporated to the extent that no conflict arises between that incorporated material and the existing disclosure material.

CLAIMS

What is claimed is:

1. A surgical instrument, comprising:

a shaft having proximal and distal ends defining an axis therebetween, wherein the shaft is flexible and sized for insertion into the working channel of a flexible endoscope, and wherein the shaft comprises:

a first tube having a first channel extending from the proximal end of the first tube to the distal end of the first tube, wherein the distal end of the first tube is formed into a tissue penetrating tip, wherein at least a portion of the first channel is adapted to retain a second tube;

the second tube having a second channel extending from the proximal end of the second tube to the distal end of the second tube, wherein the distal end of the second tube is a blunt tip, wherein the second channel is adapted to retain at least one suture anchor, and wherein the second tube includes an exit port adapted for ejecting suture anchors;

a tag pusher;

a stylet pusher; and

a compression member disposed between the stylet pusher and the proximal end of the second tube.

2. The surgical instrument of claim 1, wherein the tag pusher is at least partially contained within the stylet pusher.

3. The surgical instrument of claim 2, wherein the tag pusher extends from the stylet pusher, through the compression member, and into the second channel to eject the suture anchor.
4. The surgical instrument of claim 1, wherein the compression member is in an expanded position.
5. The surgical instrument of claim 4, wherein the compression member enters into a compressed position when the blunt tip is pressed against tissue to be penetrated.
6. The surgical instrument of claim 5, wherein the compression member allows the first tube to extend past the second tube to penetrate tissue when a specified amount of force is applied to the blunt tip.
7. The surgical instrument of claim 1, wherein the first tube contains a slot in the first channel which corresponds with the exit port of the second tube.
8. The surgical instrument of claim 7, wherein the slot and the exit port are configured to allow a suture to run from the suture anchor proximally towards the proximal end of the surgical instrument.
9. The surgical instrument of claim 1, wherein the second tube is slidably retained in the first tube.

10. A surgical instrument, comprising:

a shaft having proximal and distal ends defining an axis therebetween, wherein the shaft is flexible and sized for insertion into the working channel of a flexible endoscope, and wherein the shaft comprises:

a first tube having a first channel extending from the proximal end of the first tube to the distal end of the first tube, wherein at least a portion of the first tube is adapted to retain a second tube;

the second tube having a second channel extending from the proximal end of the second tube to the distal end of the second tube, wherein the distal end of the second tube is formed into a tissue penetrating tip, and wherein the second channel is adapted to retain at least one suture anchor; and

a tag pusher, wherein the tag pusher comprises a first member and a second member connected with a compression member.

11. The surgical instrument of claim 10, wherein the tag pusher extends at least partially into the second channel.

12. The surgical instrument of claim 10, wherein a suture anchor is retained at a distal end of the tag pusher.

13. The surgical instrument of claim 10, wherein the suture anchor extends distally past the tissue penetrating tip in a shielding position.

14. The surgical instrument of claim 10, wherein the compression member compresses when a force is applied to the suture anchor.

15. The surgical instrument of claim 14, wherein the compression member enters into a compressed position when the suture is pressed against tissue to be penetrated.

16. The surgical instrument of claim 15, wherein the compression member allows the second tube to extend past the suture anchor to penetrate tissue when a specified amount of force is applied to the suture anchor.

17. The surgical instrument of claim 16, wherein the suture anchor is ejected from the second channel once the tissue penetrating tip has punctured the tissue.

18. A method comprising:

pressing a first member of a surgical instrument against a patient's tissue;

retracting the first member into a second member of the surgical instrument by applying a sufficient amount of force to overcome the force exerted on the first member by a compression member;

penetrating the patient's tissue;

deploying a suture anchor applicator on a distal side of the patient's tissue; and

removing the first member and the second member from the patient's tissue.

19. The method of claim 18, wherein the suture anchor may be deployed by firing a tag pusher.

20. The method of claim 18, wherein the suture anchor may be deployed by the springing action of the compression member.

21. The method of claim 18, further comprising:
sterilizing the surgical instrument; and
storing the surgical instrument in a sterile container.

1/16

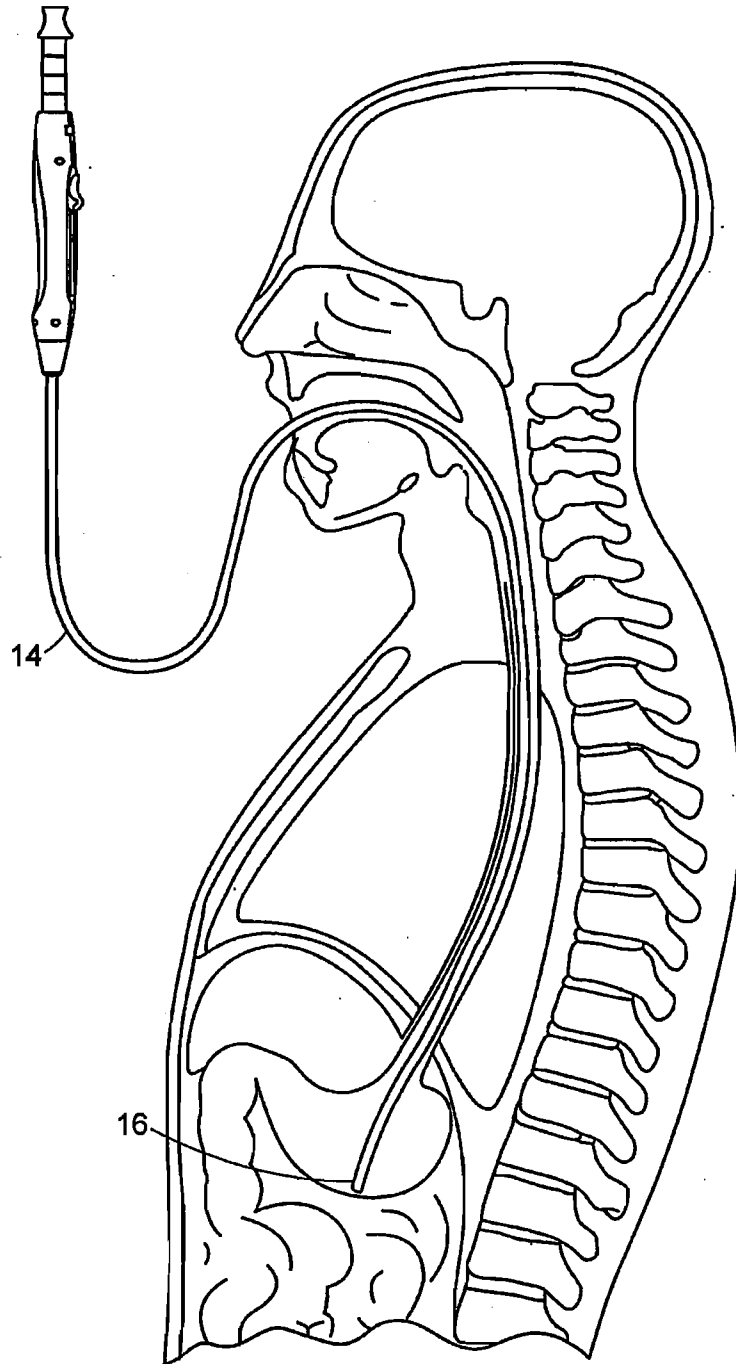

FIG. 1

2/16

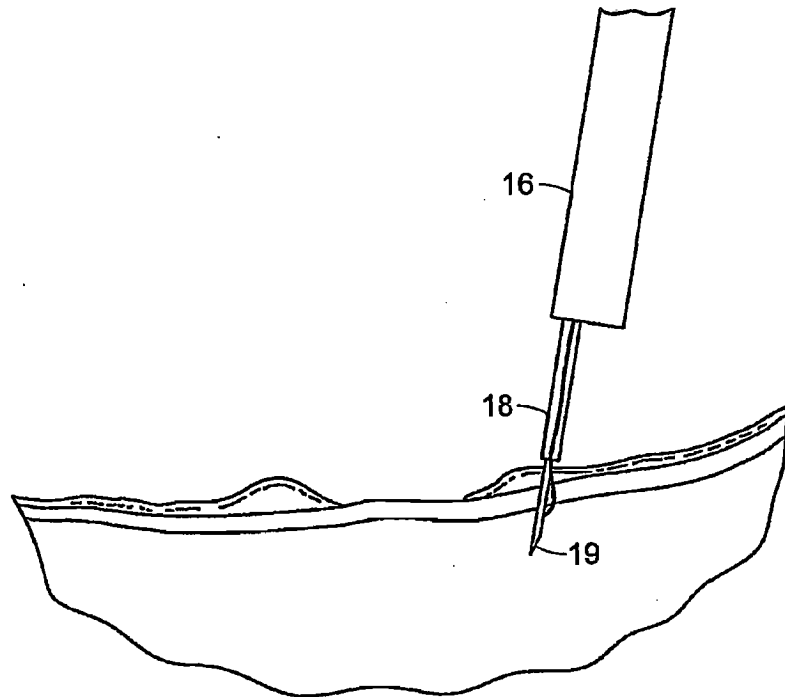

FIG. 2 (PRIOR ART)

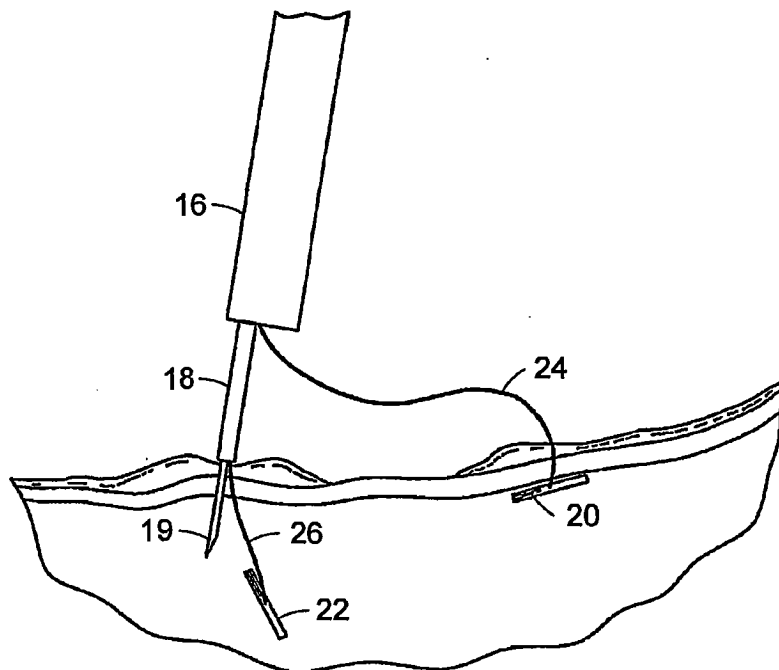

FIG. 3 (PRIOR ART)

3/16

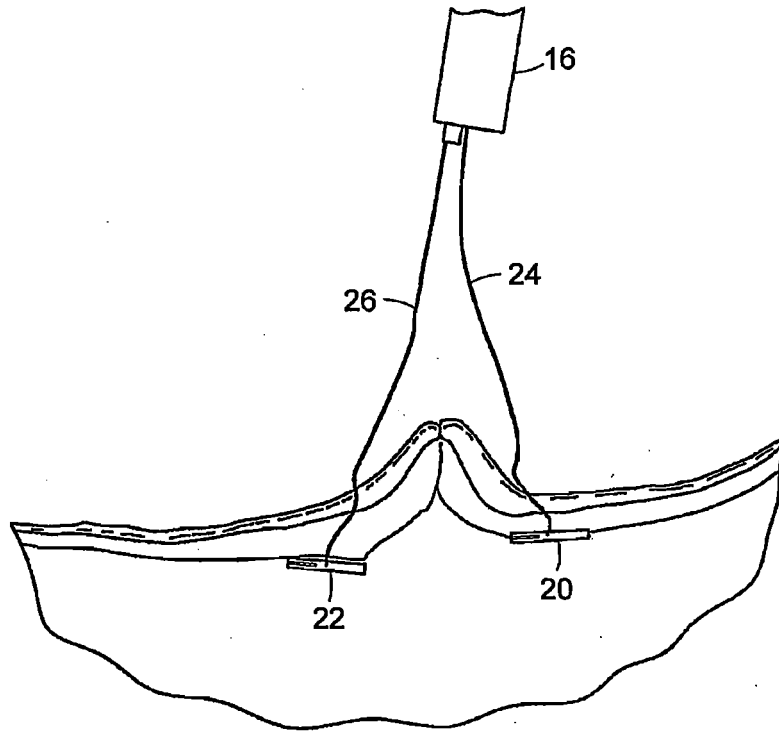

FIG. 4 (PRIOR ART)

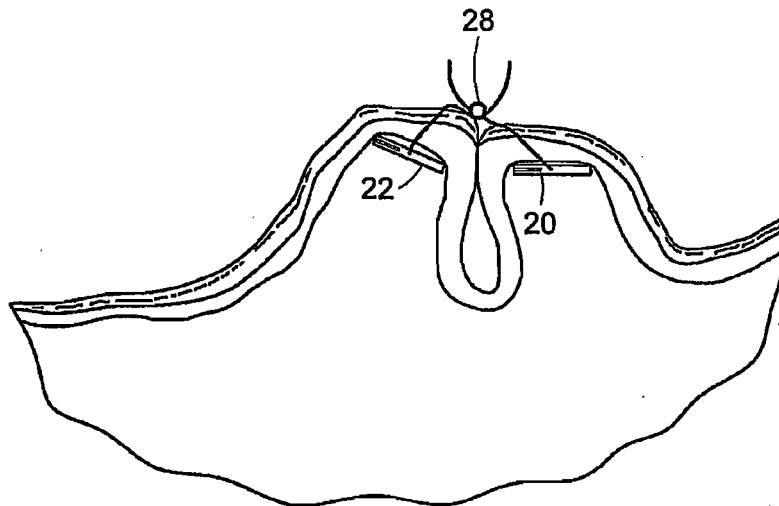

FIG. 5 (PRIOR ART)

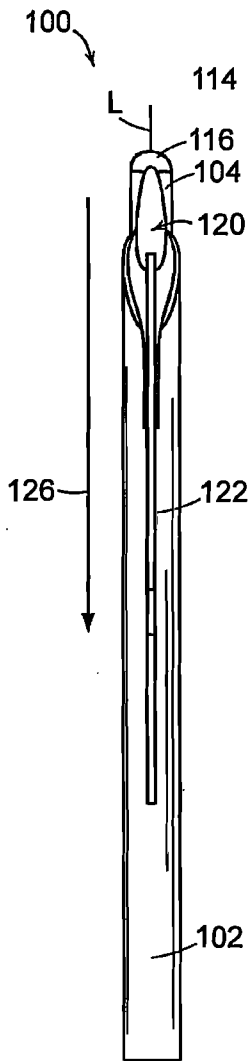

FIG. 6A

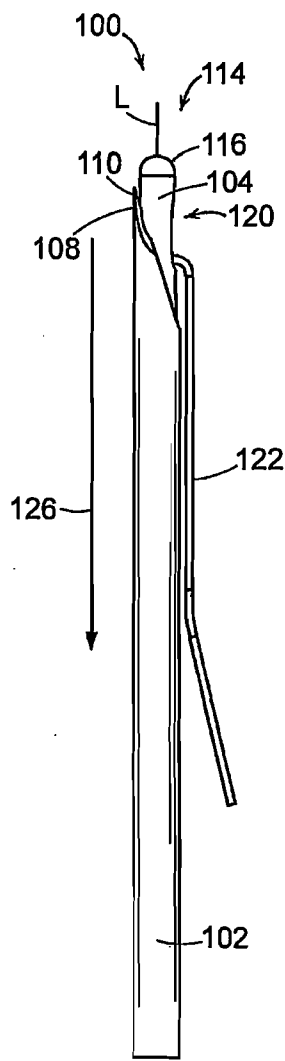

FIG. 6B

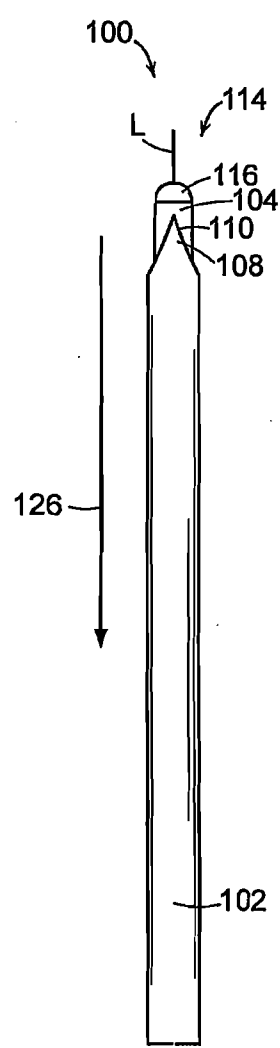

FIG. 6C

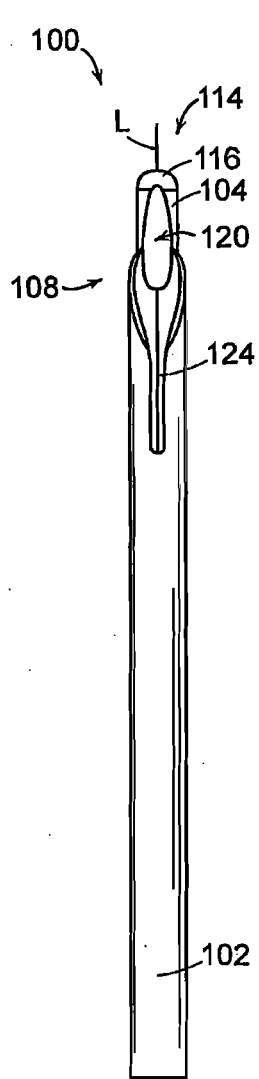

FIG. 7A

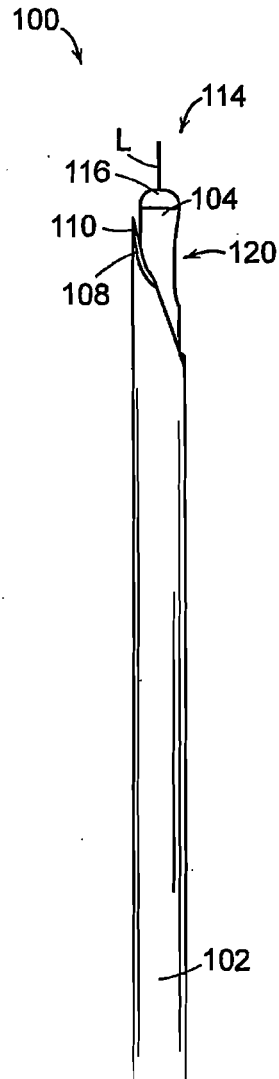

FIG. 7B

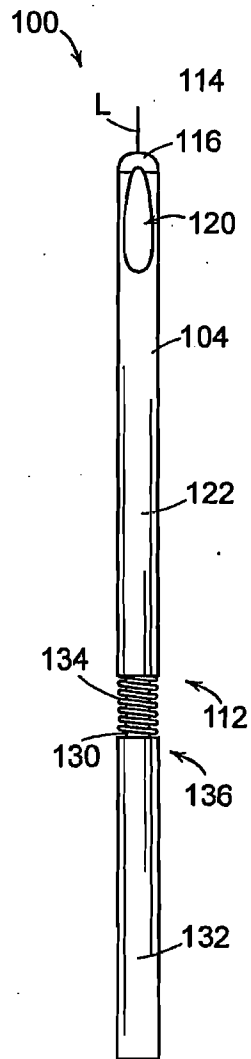

FIG. 8A

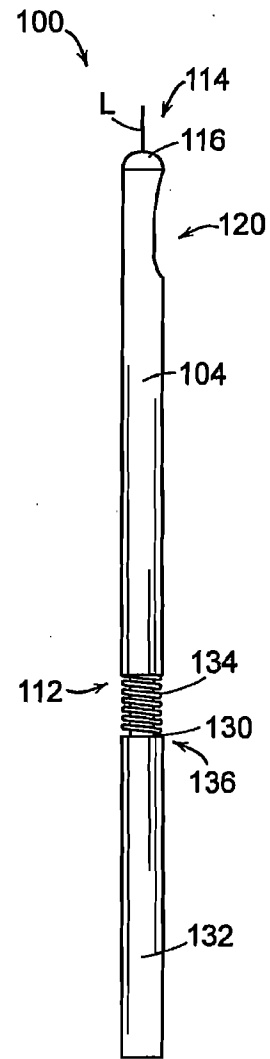

FIG. 8B

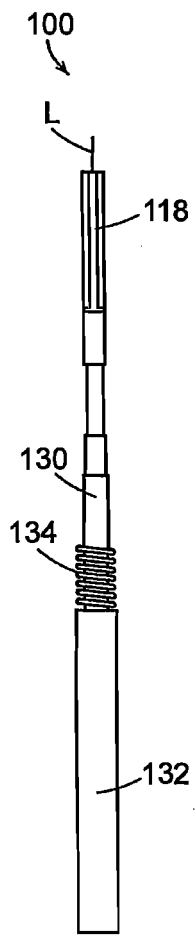

FIG. 9A

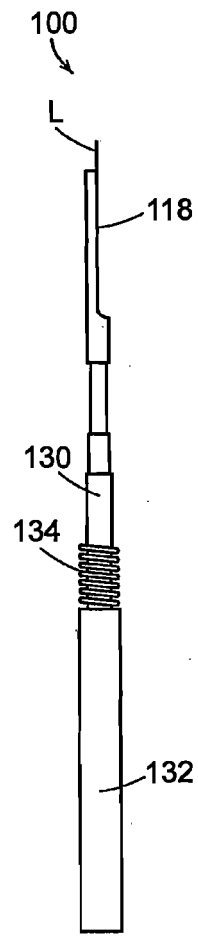

FIG. 9B

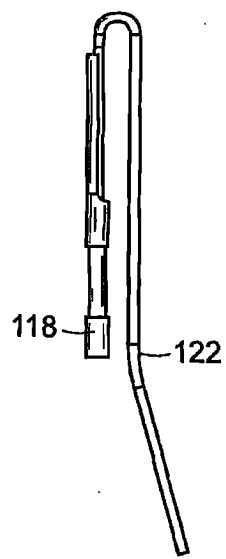
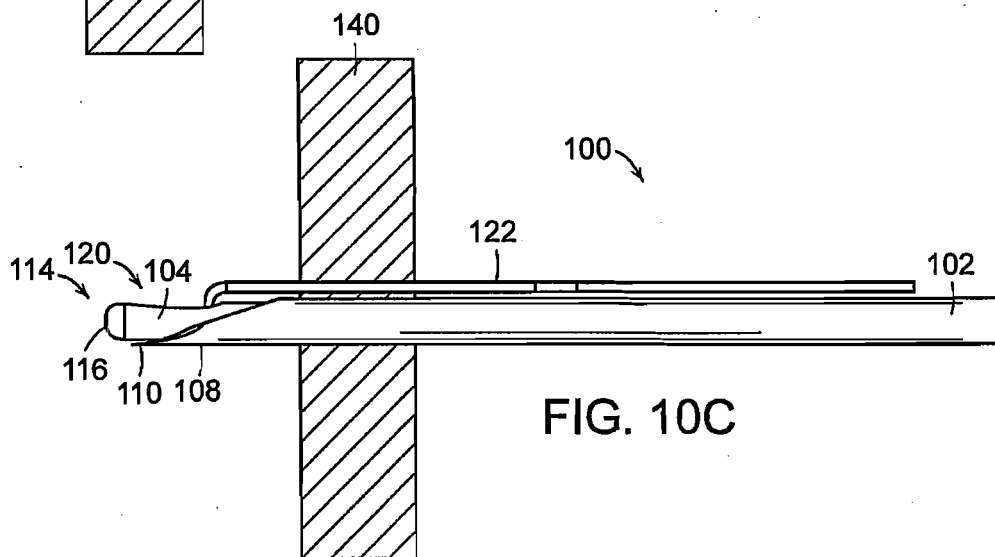
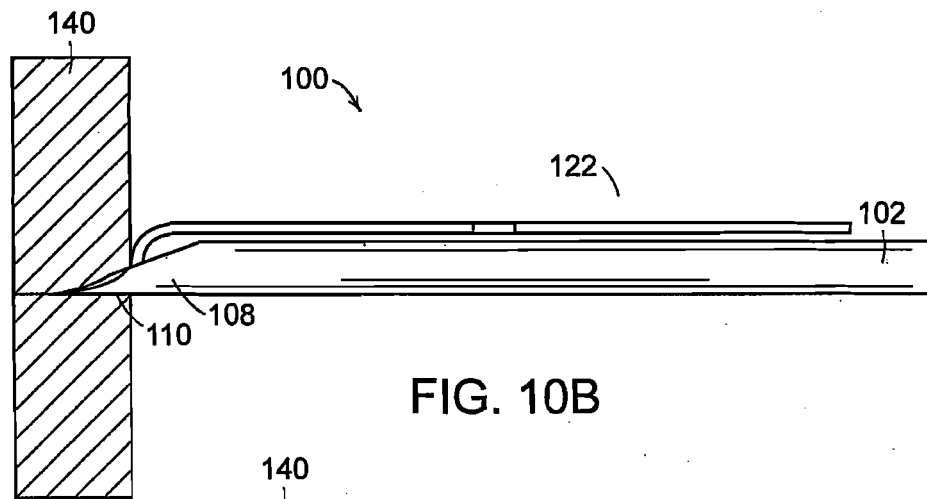
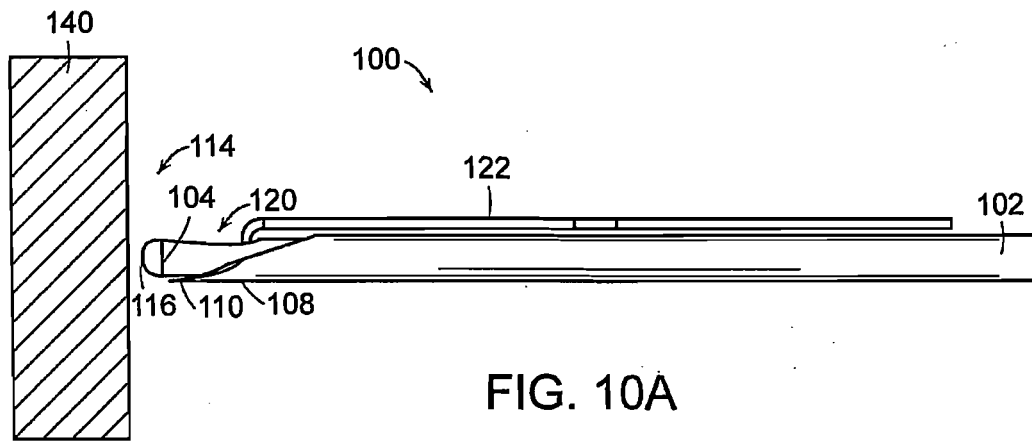

FIG. 9C



FIG. 9D

9/16



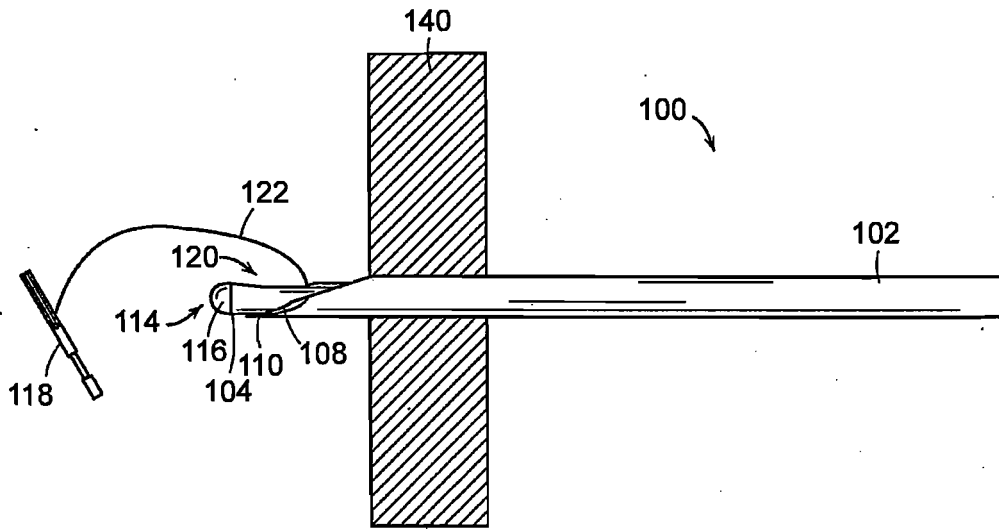

FIG. 10D

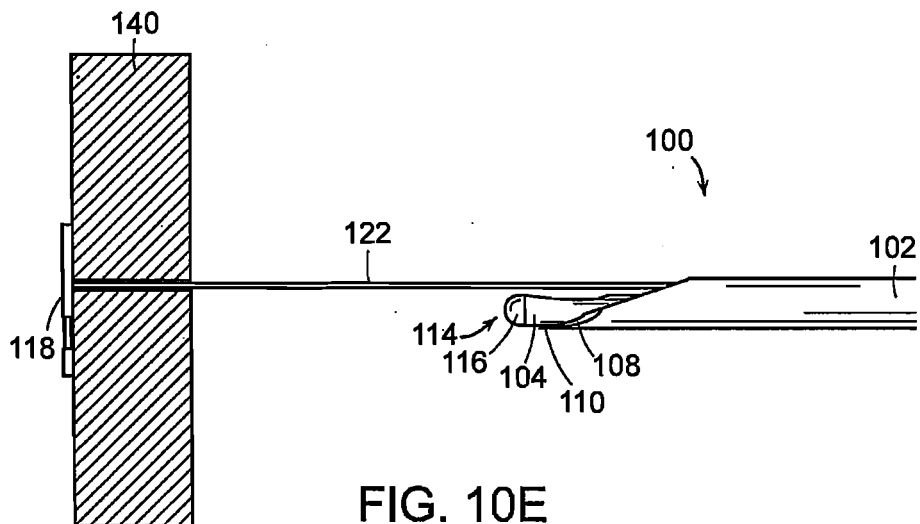

FIG. 10E

200 ↘

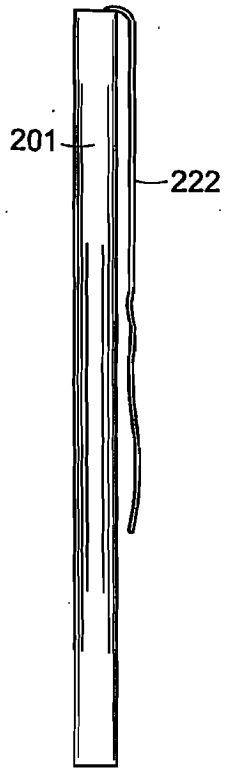

FIG. 11A

200 ↘

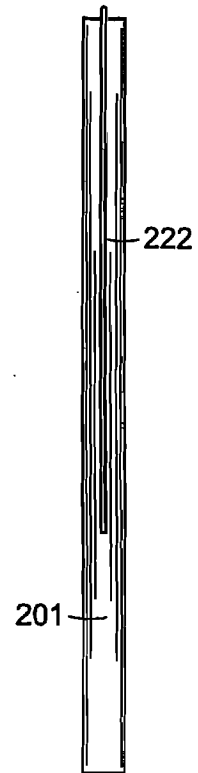

FIG. 11B

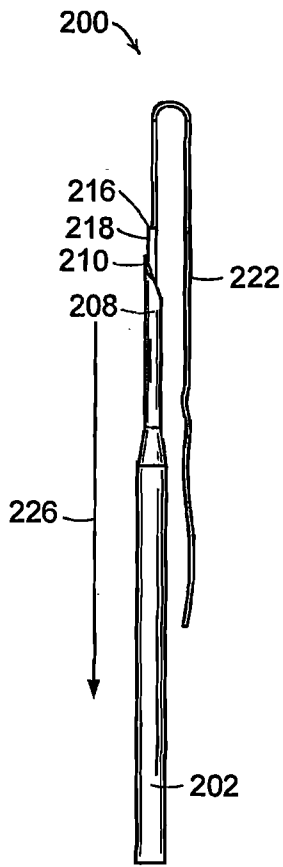

FIG. 12A

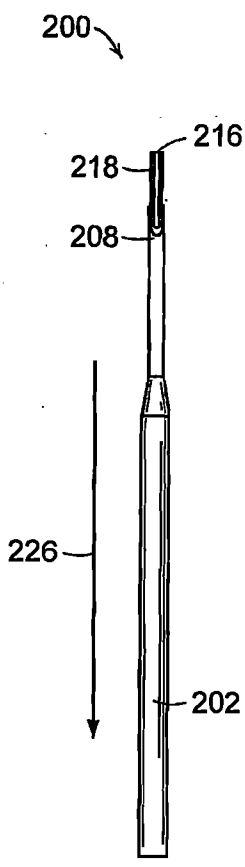

FIG. 12B

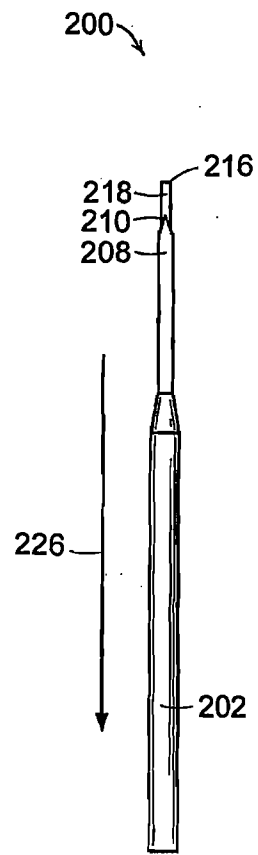

FIG. 12C

200 ↘

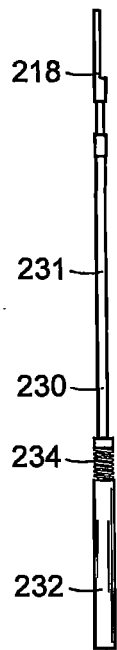

FIG. 13A

200 ↘

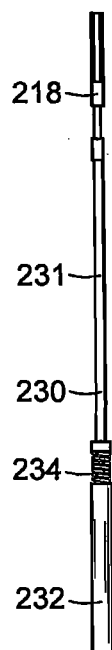
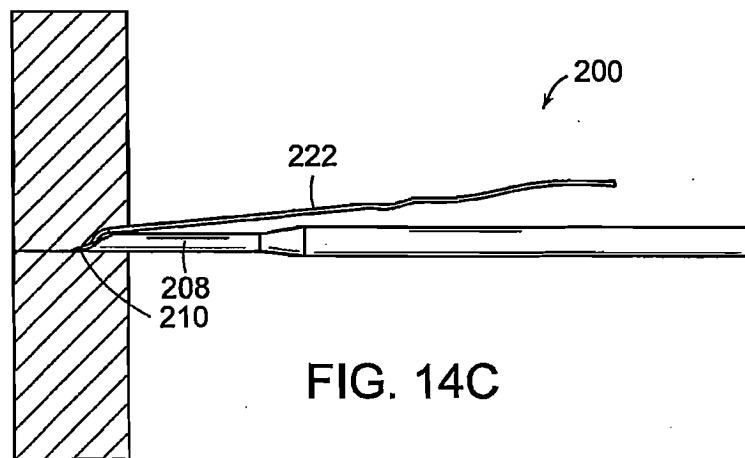
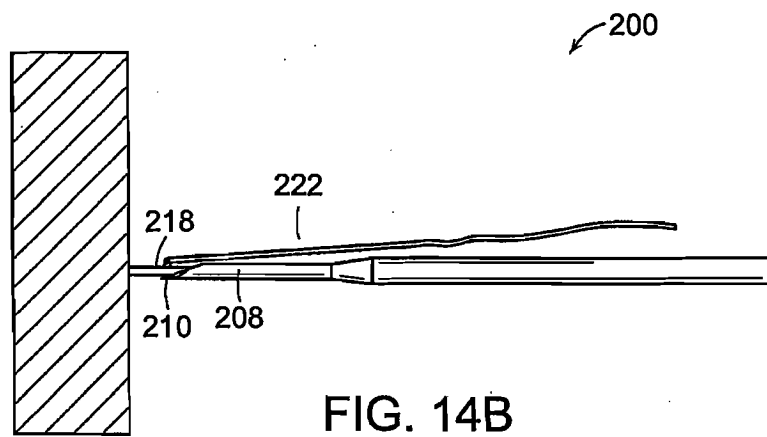
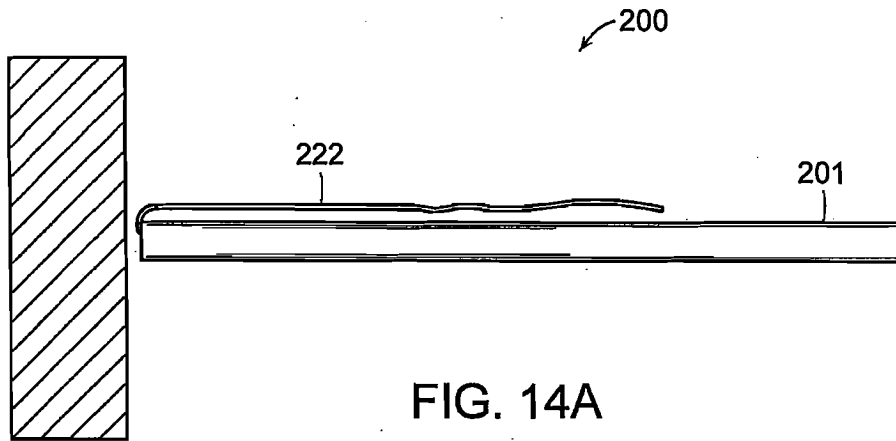

FIG. 13B

14/16



15/16

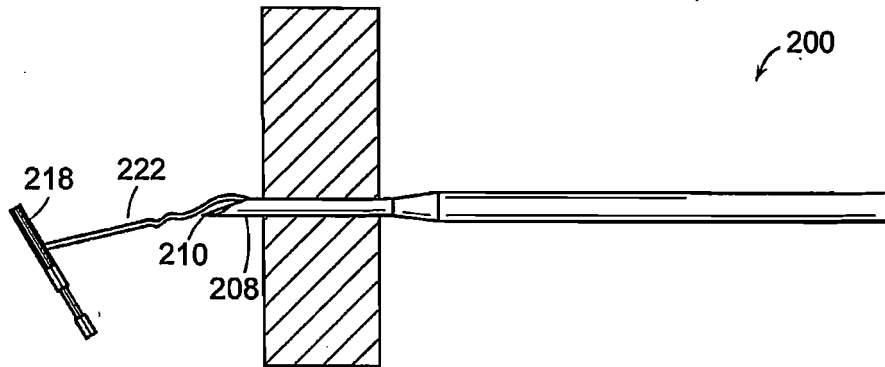

FIG. 14D

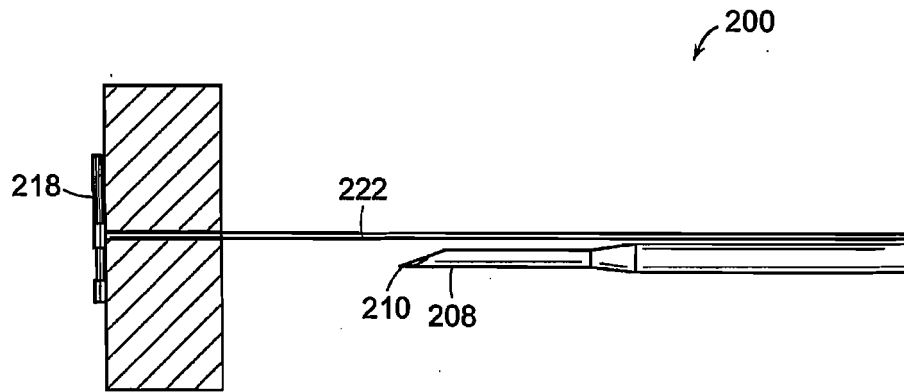

FIG. 14E

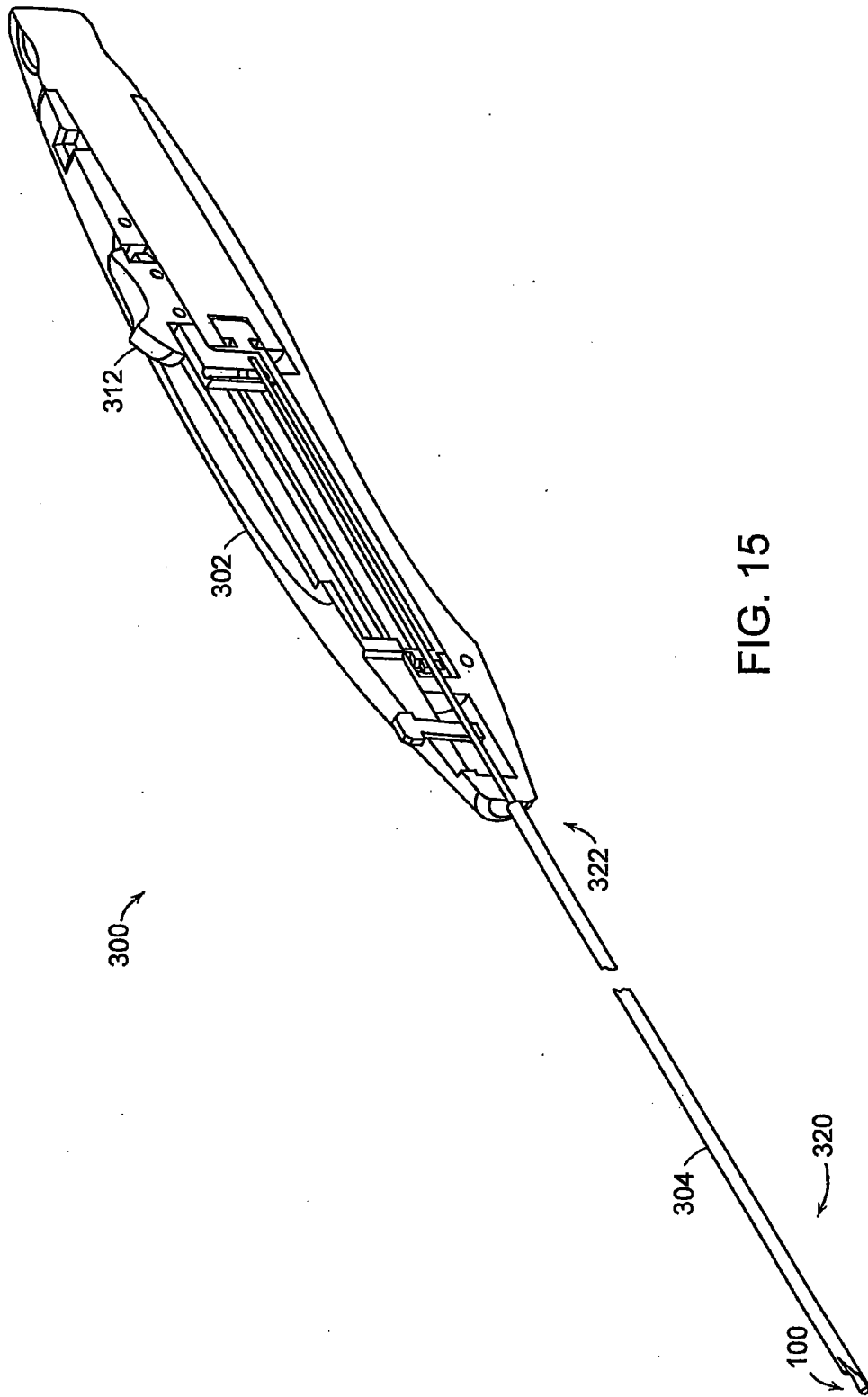

FIG. 15

INTERNATIONAL SEARCH REPORT

International application No

PCT/US2009/047599

A. CLASSIFICATION OF SUBJECT MATTER

INV. A61B17/04

ADD. A61B17/06

According to International Patent Classification (IPC) or to both national classification and IPC

B. FIELDS SEARCHED

Minimum documentation searched (classification system followed by classification symbols)

A61B

Documentation searched other than minimum documentation to the extent that such documents are included in the fields searched

Electronic data base consulted during the international search (name of data base and, where practical, search terms used)

EPO-Internal

C. DOCUMENTS CONSIDERED TO BE RELEVANT

Category*	Citation of document, with indication, where appropriate, of the relevant passages	Relevant to claim No.
Y	US 5 330 488 A (GOLDRATH MILTON H [US]) 19 July 1994 (1994-07-19) abstract; figures 1-6 column 2, lines 20-59	1-9, 14-17
X	US 2007/100376 A1 (MIKKAICHI TAKAYASU [JP] ET AL) 3 May 2007 (2007-05-03)	10-13
Y	abstract; figures 1,2,4a-4b,8	1-9, 14-17
X	US 2007/112425 A1 (SCHALLER LAURENT [US] ET AL) 17 May 2007 (2007-05-17)	10-13
X	abstract; figures 2,5a-5f,27-29	
X	EP 1 769 749 A (OLYMPUS MEDICAL SYSTEMS CORP [JP]) 4 April 2007 (2007-04-04)	10-13
	abstract; figures 1-3,7,20	

 Further documents are listed in the continuation of Box C. See patent family annex.

* Special categories of cited documents:

A document defining the general state of the art which is not considered to be of particular relevance

E earlier document but published on or after the international filing date

L document which may throw doubts on priority claim(s) or which is cited to establish the publication date of another citation or other special reason (as specified)

O document referring to an oral disclosure, use, exhibition or other means

P document published prior to the international filing date but later than the priority date claimed

T later document published after the international filing date or priority date and not in conflict with the application but cited to understand the principle or theory underlying the invention

X document of particular relevance; the claimed invention cannot be considered novel or cannot be considered to involve an inventive step when the document is taken alone

Y document of particular relevance; the claimed invention cannot be considered to involve an inventive step when the document is combined with one or more other such documents, such combination being obvious to a person skilled in the art.

& document member of the same patent family

Date of the actual completion of the international search

2 September 2009

Date of mailing of the international search report

09/09/2009

Name and mailing address of the ISA/

European Patent Office, P.B. 5818 Patentlaan 2
NL - 2280 HV Rijswijk
Tel. (+31-70) 340-2040,
Fax: (+31-70) 340-3016

Authorized officer

Macaire, Stéphane

INTERNATIONAL SEARCH REPORT

International application No.
PCT/US2009/047599

Box No. II Observations where certain claims were found unsearchable (Continuation of item 2 of first sheet)

This international search report has not been established in respect of certain claims under Article 17(2)(a) for the following reasons:

1. Claims Nos.: 18-21
because they relate to subject matter not required to be searched by this Authority, namely:
Rule 39.1(iv) PCT - Method for treatment of the human or animal body by surgery
2. Claims Nos.:
because they relate to parts of the international application that do not comply with the prescribed requirements to such an extent that no meaningful international search can be carried out, specifically:
3. Claims Nos.:
because they are dependent claims and are not drafted in accordance with the second and third sentences of Rule 6.4(a).

Box No. III Observations where unity of invention is lacking (Continuation of item 3 of first sheet)

This International Searching Authority found multiple inventions in this international application, as follows:

1. As all required additional search fees were timely paid by the applicant, this international search report covers all searchable claims.
2. As all searchable claims could be searched without effort justifying an additional fees, this Authority did not invite payment of additional fees.
3. As only some of the required additional search fees were timely paid by the applicant, this international search report covers only those claims for which fees were paid, specifically claims Nos.:
4. No required additional search fees were timely paid by the applicant. Consequently, this international search report is restricted to the invention first mentioned in the claims; it is covered by claims Nos.:

Remark on Protest

- The additional search fees were accompanied by the applicant's protest and, where applicable, the payment of a protest fee.
- The additional search fees were accompanied by the applicant's protest but the applicable protest fee was not paid within the time limit specified in the invitation.
- No protest accompanied the payment of additional search fees.

INTERNATIONAL SEARCH REPORT

Information on patent family members

International application No

PCT/US2009/047599

Patent document cited in search report		Publication date	Patent family member(s)	Publication date
US 5330488	A	19-07-1994	US 5501691 A	26-03-1996
US 2007100376	A1	03-05-2007	US 2007276424 A1	29-11-2007
US 2007112425	A1	17-05-2007	NONE	
EP 1769749	A	04-04-2007	JP 2007090062 A	12-04-2007
			US 2007073319 A1	29-03-2007