



(19) **United States**

(12) **Patent Application Publication**
Kim

(10) **Pub. No.: US 2007/0100517 A1**

(43) **Pub. Date: May 3, 2007**

(54) **ATPS FOR CONTROLLING TRAIN USING DATA COMMUNICATION**

(52) **U.S. Cl. 701/19; 246/167 R**

(76) **Inventor: Bong-Taek Kim, Seoul (KR)**

(57) **ABSTRACT**

Correspondence Address:
ROYLANCE, ABRAMS, BERDO & GOODMAN, L.L.P.
1300 19TH STREET, N.W.
SUITE 600
WASHINGTON,, DC 20036 (US)

The present invention relates to an automatic train protection stop (ATPS) device. The ATPS of the present invention is provided with both the functions of an automatic train protection (ATP) and an automatic train stop (ATS) by adding a K-Balise, on the ground, which is capable of transmitting ground information using a small air-gap data communication, and a ground information memory pack on a train. The present invention includes an on-board equipment including a main device, an on-board antenna, a speed detector connected to a shaft of wheel, an operation switch, a train controller, and a communication module; and a ground equipment including an ATS beacon connected to a track occupancy detection device, a K-Balise using data communication, and a program part for inputting ground information data to the K-Balise. According to the present invention, it is possible to implement the high-speed data communication and to secure the security and reliability by operating in an available distance in electric source free scheme. Also, it has advantages of self-testing and operation recoding and maintaining functions and the improvement of the stability by protecting the no reaction and malfunctioning.

(21) **Appl. No.: 10/562,558**

(22) **PCT Filed: Jul. 2, 2004**

(86) **PCT No.: PCT/KR04/01642**

§ 371(c)(1),
(2), (4) **Date: Dec. 28, 2005**

(30) **Foreign Application Priority Data**

Jul. 2, 2003 (KR) 10-2003-0044620

Publication Classification

(51) **Int. Cl.**
B61L 3/00 (2006.01)

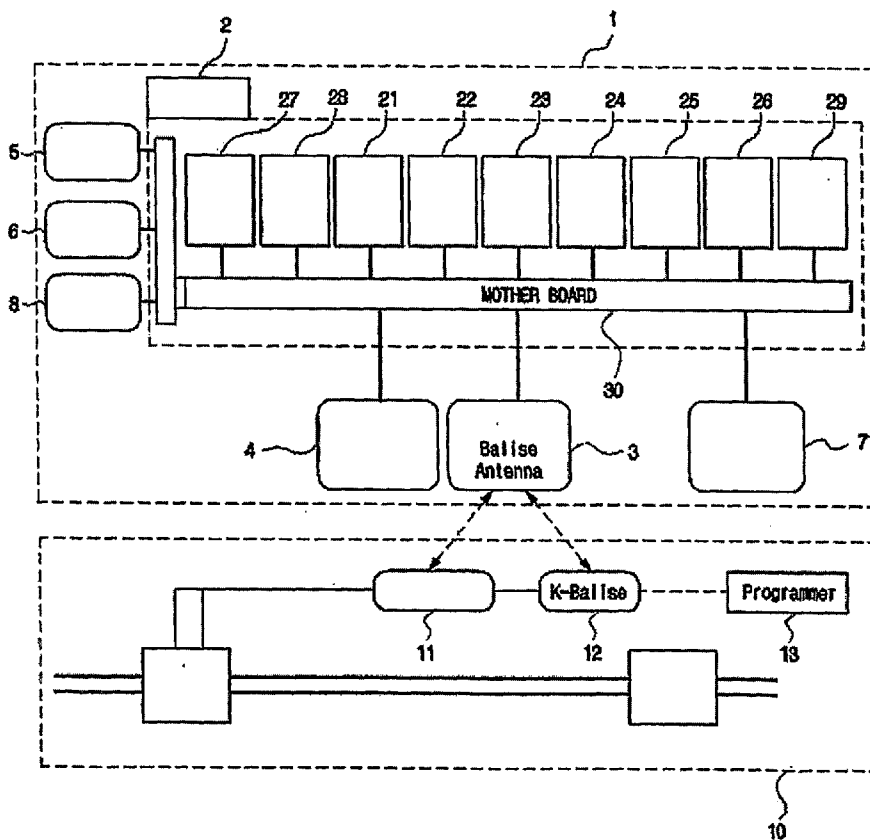

FIG. 1

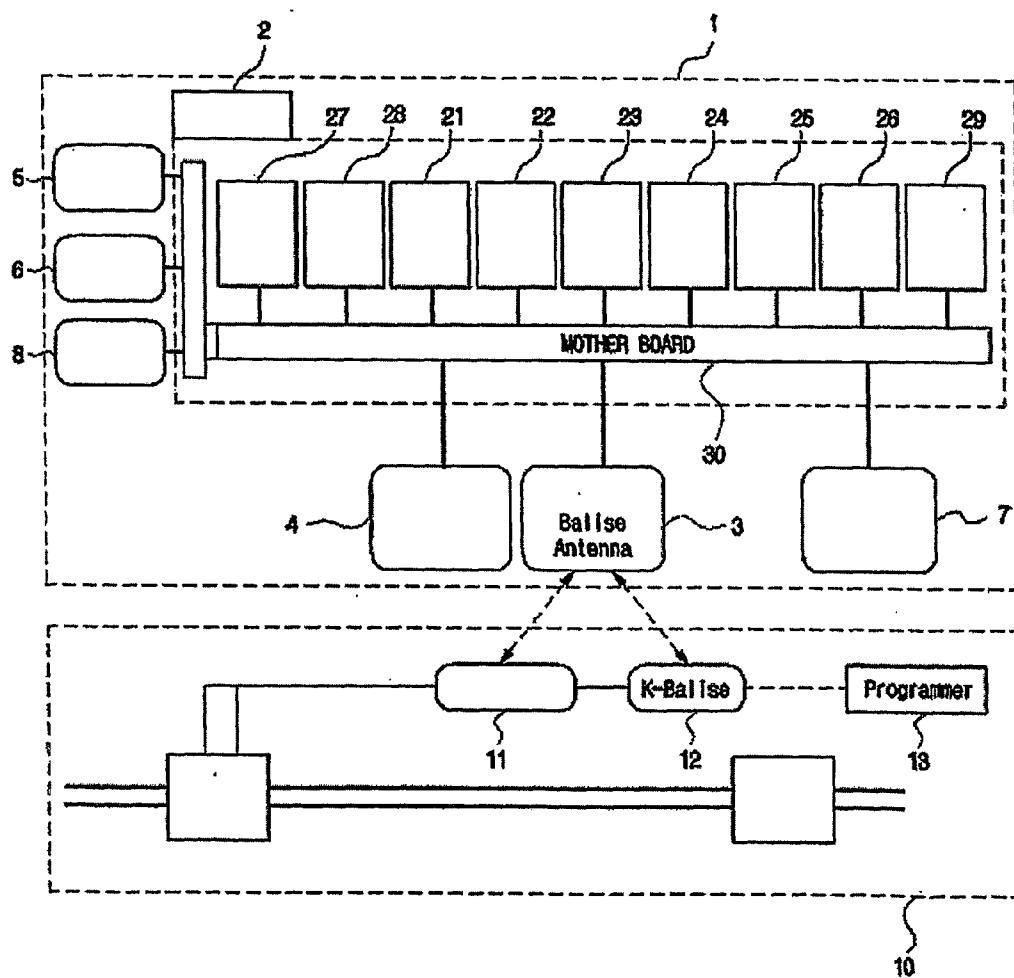

FIG.2

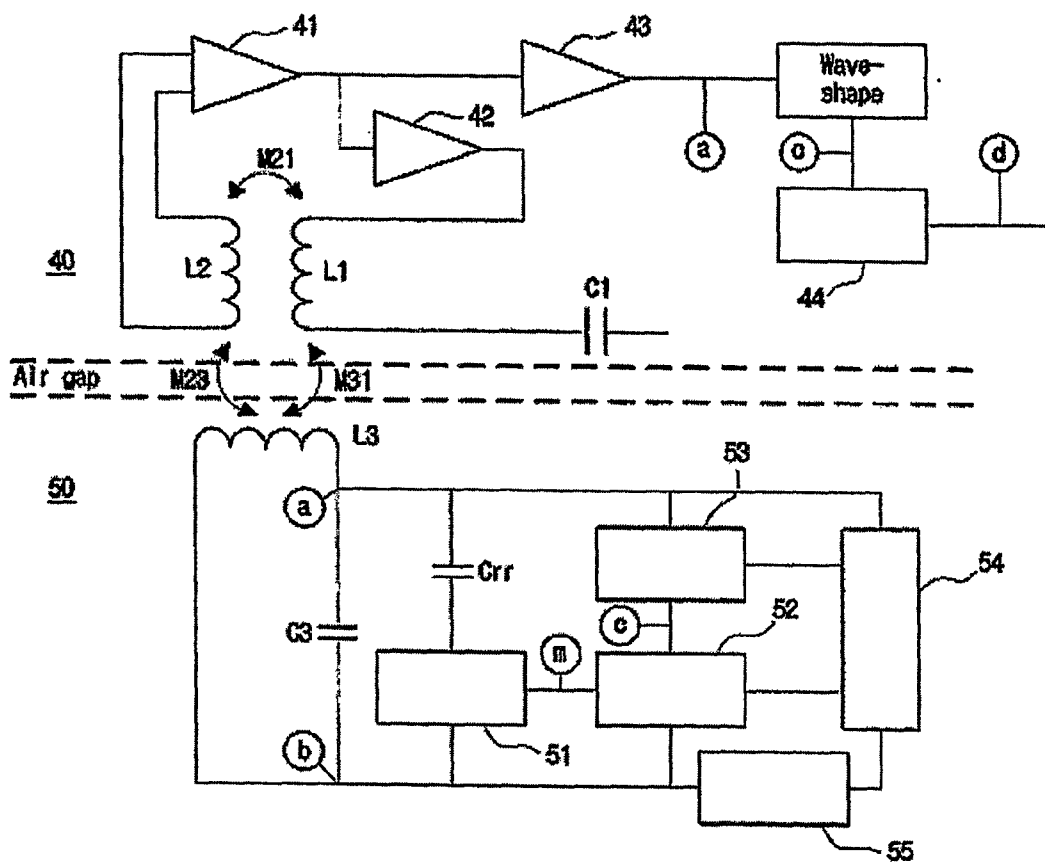

FIG.3

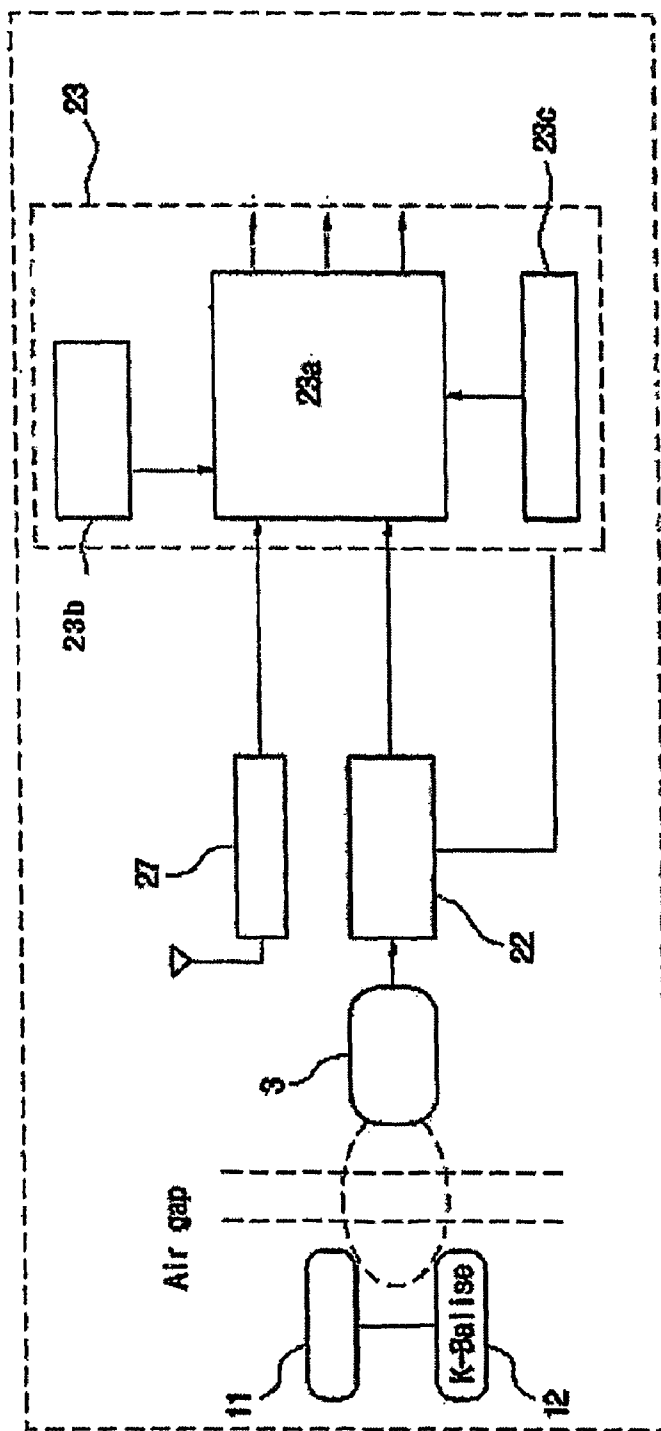

FIG.4

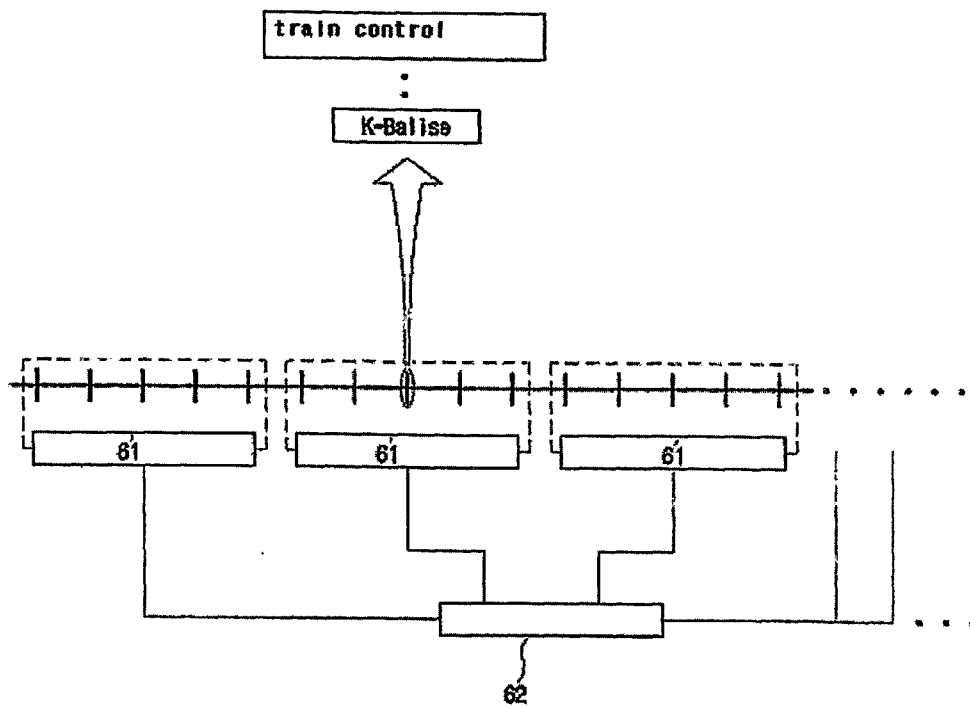
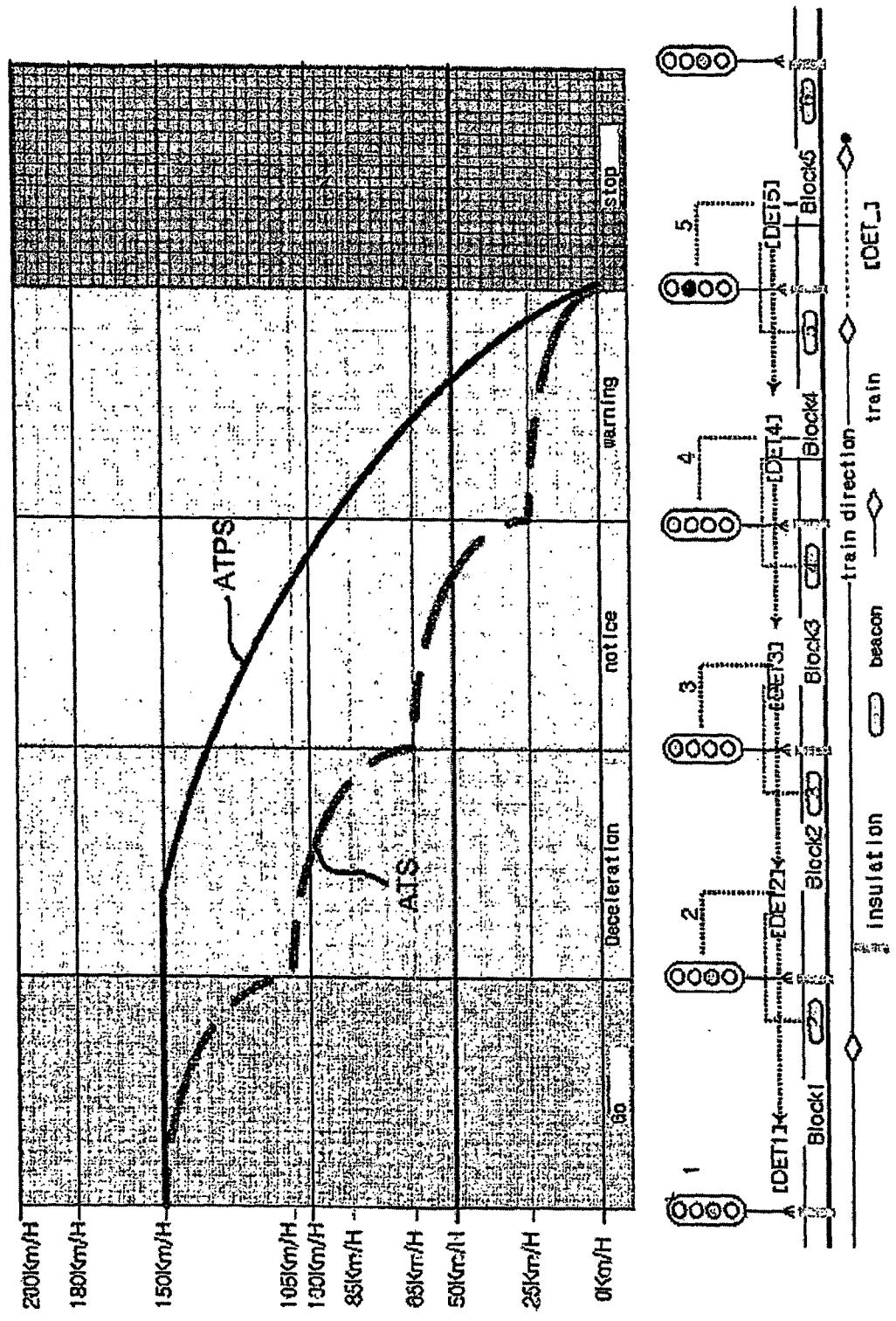

FIG.5



ATPS FOR CONTROLLING TRAIN USING DATA COMMUNICATION

TECHNICAL FIELD

[0001] The present invention relates to an automatic train protection stop (ATPS) device. Particularly, the present invention relates to the ATPS having both the functions of an automatic train protection (ATP) and an automatic train stop (ATS) by adding a K-Balise, on the ground, which is capable of transmitting ground information using a small air-gap data communication and a ground information memory pack on a train.

BACKGROUND ART

[0002] Typically, a device transmitting ground information for an automatic train stop is called Balise. The Balise is a device for transmitting, using data communication, ground information such as ground operation conditions, distance and position of the beacon, and a target speed from a ground equipment to an on-board equipment.

[0003] The K-Balise adapted to the present invention as a part of the current ATP is a Balise integrating a beacon, a tag (Transponder or Loop Coil), card or terminal. Particularly, it includes a Euro Balise and is called as K-Balise in the present invention.

[0004] There have been many problems in the conventional railroad section such as bottleneck problem and safety accident caused by increase of the railroad capacitance and running speed. Thus, it is required to shorten the operation time, provide operation information, and secure the safety operation as an auxiliary function. When the conventional railroad is improved so as to be operated in high speed, it is required to develop an automatic train protection stop device capable of operating at over 200 Km/h.

[0005] Especially, it is required to control the distance-to-go by providing the ground information for securing reliability and to introduce a communication method for securing the reliable communication in small air gap space.

[0006] Typically, the conventional communication method performed by occupying space uses a propagation characteristic of the electromagnetic wave. It is advantageous for long propagation distance, but does not guarantee the reliability and the security.

[0007] Recently, a communication method adapted to the cards utilizes the narrow space data communication. However, this communication method has very low communication speed such that it is difficult to utilize for a high speed mobile such as train.

[0008] Especially, there is a shortcoming in that a bandwidth of the ATS, which is widely spread for the national railroad signal system, has very low communication speed.

[0009] In the meantime, the communication method utilized for obtaining information for analyzing the absolute position in railroad signal control requires high data rate and high reliability and security.

[0010] The narrow space data communication is mainly used for point-to-point data communication required the security and reliability in comparison with the long distance broad area communication using the free space propagation.

[0011] The narrow space communication used for RF-ID includes a main device (reader) for providing energy and collecting data and a Balise for being provided by the energy and carrier and transmitting the retained data.

DISCLOSURE OF INVENTION

[Problem to be Solved]

[0012] The conventional narrow space communication has drawbacks in that the communication speed and distance is dependant on the using frequency, especially, the communication speed is very low at a low frequency.

[0013] Even though the transponder, Balise, or tag adapted to the ATP for controlling the train requires the high reliability and security, they do not show the enough performance in the communication speed, reliability, and security in the conventional ATS frequency bandwidth.

[0014] Also, the communication speed is limited even with the RF-ID, such that it is limited for using with the applications requiring massive data processing. Accordingly, the conventional technique is limited to be used with the Balise requiring high reliability and security.

[Technical Solution]

[0015] In order to achieve the above objects, the present invention provides a ATPS having both the ATP and ATS functions by installing the K-Balise on the ground equipment for transferring the ground information using the data communication method and adding a ground information memory pack on the train. Particularly, an informational ATS is implemented by adding a data communication to the ATS frequency self-reaction concept for the purpose of providing a limit speed and distance-to-go.

[0016] Also, the present invention has the functions of providing the on-board operation information, adding auxiliary operation, self-testing the system before running, and storing the operation records.

[Useful Effect]

[0017] According to the present invention, it is possible to implement the ATP and ATS functions using the data communication method. Especially, the on-board equipment of the ATP system directs the operation limit speed, reduce the operation speed below the limit speed or activates emergency brake when the operation speed exceeds the limit speed, and then releases the constant brake or brake mode when the speed is recovered to be lower than the limit speed. The ATPS of the present invention has a function providing the on-board operation information and an auxiliary operation function, a self-testing function for testing the system before the train starting, and a storage function for recording and maintaining the operation records so as to efficiently perform the speed control per tract section according to the ATS frequency.

[0018] Since the ATPS of the present invention utilizes an electric source-free data communication method, it is possible to secure the high security and reliability during the high-speed communication in every frequency bandwidths.

[0019] Also, in the present invention it is possible to increase the utilization of the rail by increasing the efficiency of the distance-to-go control with the ground information, and furthermore to increase the stability and accuracy of the

train control by checking the positions of the train in various view points using the beacon, K-Balise, speed detector, or/and GPS receiver. Particularly, it is possible to transmitting the massive data by selecting the frequencies according to the amount of the information and to improve the stability by protecting the no reaction and malfunctioning.

BRIEF DESCRIPTION OF THE DRAWINGS

[0020] FIG. 1 is a block diagram illustrating the ATPS device according to the present invention;

[0021] FIG. 2 is a conceptual view for illustrating a narrow space data communication system;

[0022] FIG. 3 is a drawing for illustrating the target distance controller of a main device of the present invention;

[0023] FIG. 4 is a conceptual view illustrating the control system of K-Balise; and

[0024] FIG. 5 is a graph showing curves for illustrating the operation controls of the conventional ATS and ATPS.

BEST MODE FOR CARRYING OUT THE INVENTION

[0025] Main technical structure is characterized by an on-board equipment including a main device having a plurality of circuits for implementing an ATS function and an ATP function, an on-board antenna integrated with a on-board coil and an oscillator, a rotary type speed detector connected to a shaft of wheel, an operation information displayer providing speed information, ground information, and operation information, a operation switch for selecting an operation mode, a train controller for controlling a brake of the train, and a communication module for transmitting on-board information and ground information to an central control system and receiving radio commands from the central control system; and a ground equipment including a K-Balise for transferring the ground information using an ATS member connected to a track occupancy detector through narrow space data communication, and a program part for inputting ground information data to the K-Balise.

PREFERRED EMBODIMENTS OF THE INVENTION

[0026] The present invention will be described hereinafter with reference to the accompanying drawings.

[0027] FIG. 1 is a drawing illustrating the ATPS device using a data communication according to the present invention. As shown in FIG. 1, the ATPS of the present invention includes an on-board equipment (1) and a ground equipment (10) satisfying an ATS function and an ATP function.

[0028] The on-board device includes a main device (2), an on-board antenna (3), a speed detector (4), an operation information displayer (5), an operation switch (6), a train controller (7), and communication module (8).

[0029] The ground equipment (10) includes an ATS beacon (11) and K-Balise (12) connected to a track occupancy detector and a program part for inputting data to the K-Balise (12).

[0030] The main device of the on-board equipment is a device for controlling the speed of the train and automatically stopping the train and includes a plurality of electric

circuits satisfying the ATS function and the ATP function, the electric circuit devices have respective functions as following.

[0031] The speed analyzer (21) transcripts the output of the speed detector (21) into real speed information so as to constantly provide the speed information.

[0032] The dynamic frequency discriminator (22) has a function for discriminating the resonant frequency generated by the resonance of the ATS beacon (11) and the on-board antenna (3).

[0033] The target distance controller (23) receives the information on the corresponding section (current signal information and rail information) when the K-Balise (12) on the ground and the on-board antenna (3) come close each other and position and moving distance information of the train so as to constantly calculate and provide the target distance and speed and the secure operation speed of the train.

[0034] The operation controller (24) entirely controls the entire operations and constantly provides the manipulation information to the system. Also, the operation controller (24) selects an operation mode, sets a wheel arc, establishes a communication with an exterior device, and monitors a speed calculation function of the speed analyzer (21).

[0035] The output controller (25) outputs the speed information and the current ATS information existed in the system and contact point signal for limiting the excessive speed of the train on the basis of the ATP limit speed.

[0036] The electric source converter (26) changes the electric source of the train to the electric source of the main device.

[0037] The GPS receiver (27) provides the position information of the train using the global positioning system (GPS).

[0038] The information recording device (28) is a USB card or a flash memory card including a memory means of flash memory, a controller for controlling the data input and output, and a connection means of USB; and is readable/writable of the fixed information and variable information of the corresponding section on the ground, exchangeable of the information on and off, and facilitates the information exchange. The information-recording device (28) records the fixed information and variable information of the corresponding sections on the ground and constantly provides the information to the system.

[0039] Here, the fixed information of the ground information is the data such as the rail conditions including the position of the beacon, curve section, gradient section, and the like, and the data automatically recognized and compensated while the train is running. And, the variable information of the ground information is the information on the ground, which varies on and off and is temporary, that is, the data representing the information to be controlled such as rail working or working area movement information in relation with avalanche, flood, and the like, that are inputted before the train taking out of the depot.

[0040] The interface card (29) receives the internal or intercontinental ground signals (track circuit signals) so as to process as the information and provides the system with the

information, whereby it allows to exchange the information of the track circuit signal and enables the international or intercontinental train controls regardless of the signal standards.

[0041] Furthermore, the on-board antenna (3) of the on-board equipment (1) is integrated with the on-board member coil and the oscillator so as to output the frequency and voltage variation signals according to the resonant frequency of the beacon (11). Also, the on-board antenna (3) establishes a communication link when it approaches the K-Balise (12) and receives the ground information of the rail track section which is coded by the program part (13) from the K-Balise (12).

[0042] The speed detector (4) has two devices of rotational speed detector or a Doppler speed measurement device connected to the shaft of the wheels.

[0043] The operation information displayer (5) has a digital or analog type indication function so as to display the speed information, the ground information, and the required operation information to the operator, and includes a speed indicator inside. Also, the operation information displayer (5) includes the voice output alarm device which provides the operator with the speed information and the ground information of the corresponding section, in voice, using the GPS receiver (27) and the information recording device (28). Here, the voice output alarm device checks the current position of the train using the GPS and then outputs the voice signal by backup of the ground information (fixed information and variable information) on the corresponding section. For example, the voice output alarm device outputs the voice information such as "The current section is the below-150 Km/h section" or "The current section is under-working section" so as to alarm the operator for secure operation.

[0044] The operation switch (6) provides functions for selecting an operation mode and performing a required manipulation.

[0045] The train controller (7) is device for controlling the brake system of the train, as a bimetal type contact point output device which is constantly monitored.

[0046] The communication module (8) transmits the entire ground information and on-board information about the current state of the train to the integral control system (central monitoring center) and receives the radio command so as to control the train. At this time, the exchange of the information between the communication module and the integral control system is carried out through the broadband data communication using the free space and the urgent command is directly transmitted to the train through the communication module. Here, the on-board information is the data representing the train information such as the brake characteristic and operation characteristic which is interfaced from the Train Information System (TIS) or the Train Control Monitoring System (TCMS) and is provided after being recorded in the information recording device or the target distance controller. The on-board information can be utilized as for train inspection information during the operation of the train.

[0047] In the meantime, the ATS beacon (11) of the ground equipment generates the frequency using the inductive coupling so as to create the speed control information deter-

mined for the track section and provides the ground information by checking the current position of the train.

[0048] The K-Balise (12) is a information transfer device for transmitting the ground information as the ATS beacon (11) does, such that when the on-board antenna (3) comes close it establishes the narrow space data communication link, modulates the information coded and stored by the program part, and transmits the modulated information to the main device. Here, the K-Balise (12) provides the information for changing the speed index of the train according to the tract section and the information for controlling the limit speed at each track section in consideration with the brake characteristic and operation characteristic of the train. Also, the K-Balise provides the current position information of the train for securely and accurately controlling the train.

[0049] Low part of FIG. 1 shows the data transmission procedure of the K-Balise. The program part (13) includes a notebook computer and the data transmission device so as to generate and record the data of the K-Balise beacon. The K-Balise (12) is a transponder using the oscillator output as the energy source rather than a power feeder and transmits the data recorded by the program part to the train. The ATS beacon (11), as described above, carries out the ATA function. The communication is performed between the on-board antenna (3) and ATS beacon (11) or between the on-board antenna (3) and the K-Balise (12).

[0050] In the meantime, the ATPS can be implemented in the following 4 methods.

[0051] First, a method for calculating the ground information and distance using the data by the data transmission of the K-Balise,

[0052] Second, a method for detecting the ground information, the running speed, and the distance using the information stored in the ground memory card or memory pack of the train,

[0053] Third, a method for calculating the ground information and the distance according to the signal display in the closed section, and

[0054] Fourth, a method for calculating the running speed and the distance using the ground information stored in the memory by the position information provided using the GPS.

[0055] The object of the present invention is to provide an ATPS having a data communication function in frequency adaptive concept of ATS as a combination device which is capable of improving the functions of the ATS and controlling the target distance using the narrow space data communication method modified from the RF-ID communication method.

[0056] The method for obtaining the information of the ATPS having the above object and the contents and function of the information will be explained as following.

[0057] To obtain the information of the specific position of the ground on the train which is running so fast requires high reliability and security. Since the communication method, which is completely protected from the environmental noise, is not available for using the space propagation, the inductive coupling type data communication is utilized. For example, the Balise of Europe, the transponder of Japan, and

the general commercial RF-ID are fixed carrier type such that the main device (reader) transmits the frequency signal for carrier and the terminal receives the signal to secure the electric power and modulates the received signal by changing the electric load using a back-scattering method. Here, these methods have very low modulation rate such that it is difficult to obtain the high communication speed.

[0058] On the other hand, the data communication method used in the present invention the carrier frequency (constant oscillation condition) is determined according to the oscillation circuit engaged between the main device (reader) and the terminal, i.e., between the on-board antenna and the K-Balise such that the synchronous high speed communication is implemented by securing the electric power from the carrier with the K-Balise and transmitting the data.

[0059] Accordingly, in order to secure both the ATS and ATP functions, the data communication network is implemented with the frequency band in which the ATS beacon is used so as to secure the data transmission function of the ATP, such that it is possible to transmit the massive data by selecting the frequencies according to the amount of the information, secure the security due to the operation in the available distance, and provide the ground information without electric source.

[0060] That is, in the present invention the on-board antenna integrally constructed with the on-board member and the oscillator for the ATS is installed on the train and the ATS beacon and ATS K-Balise are installed so as to simultaneously obtain the ATS and ATP functions.

[0061] In the meantime, the essential information to be transferred from the ground equipment to the on-board equipment is as following:

[0062] The ID or Marker indicating the available beacon, the maximum speed allowable in the physical environment of the section, the tolerable section speed determined by the previous train or the operation schedule, the distance to the available section (beacon), and the data frame error check information.

[0063] The above information is structured in one data frame so as to be transferred in the time at which the on-board antenna passes the beacon.

[0064] In order to transfer the information in the available communication time, the information should be compressed such that the available data is minimized with the most typical method of making a table for the data. The compressed available information and the error checking information is encapsulated in one frame and continuously and repeatedly transmitted.

[0065] FIG. 2 is a drawing illustrating an embodiment for explain the concept of the narrow space data communication system of the present invention. As shown in FIG. 2, the on-board antenna (main device reader) (40) can include a demodulator (44) having a first and a second coils (L1, L2) so as to generate a maximum output at the resonant frequency by connecting an output of a power amplifier and a capacitance (C1) to the first coil, enable to constantly oscillate by connecting the second coil to an input of the amplifier (41), and decoding the data transmitted at the K-Balise.

[0066] The K-Balise (50) can include a modulator (51), a micro control unit (52), a clock generator (53), and a storage device (54) for forming a parallel resonant circuit of L3 and C3 so as to be oscillated by the frequency close to the oscillate frequency of the on-board antenna (40); and an analysis device (55) for self-testing the operation state of the K-Balise and storing/maintaining the operation records.

[0067] Here, the modulator (51) is preferably connected to the modulation capacitor (Crr) and the parallel oscillation circuit (L3, C3) at the modulation time using the fast field effect transistor (FET). The micro control unit (52) outputs the coded data stored in the storage device to the modulator (51) at every clock cycles. The storage device (54) stores the data of the ground information coded by the program part (13).

[0068] The data communication method with the above structure will be described. If the signal is applied to the coil (L2) of the mutual inductance (M21), the signal is amplified by the first power amplifier (42) so as to constantly oscillate and the amplified signal is outputted to the power amplifier (42) and the second amplifier (43). Here, the power amplifier (42) operates the serial oscillation circuit (L1, C1) so as to output the oscillation frequency and outputs the serial oscillation frequency signal to the second amplifier (43).

[0069] At this time, if the on-board antenna (40) approaches the K-Balise (50), the frequency signal resonated by the constant oscillation frequency is applied to the K-Balise (50) so as to accumulate the power of the voltage dropped from the applied frequency signal. Accordingly, It is possible to secure the reliability using the electric source-free method for the data communication.

[0070] If the power is accumulated in the K-Balise (50), the clock generator (53) generates a standard clock using the applied frequency signal such that the micro control unit (52) is driven by the standard clock and power and reads the data of the coded ground information from the storage device at every clock cycles through the previously stored programming control (for example, 1 bit per 3 cycles of the clock) and outputs to the modulator (51).

[0071] At this time, the modulator (51) modulates the data received from the micro control unit (52) and transmits the modulated data to the on-board antenna (40). Here, the modulation scheme can be any of the frequency shift keying (FSK), the amplitude shift keying (ASK), and the pulse shift keying (PSK).

[0072] With the above modulation schemes, by selecting the frequency to be used according to the amount of the information, it is possible to transmit the massive data and secure the security due to the operation in the available distance.

[0073] If the data is transmitted from the K-Balise (50) to the on-board antenna (40), the modulated signal passes a waveform shaping circuit and then is demodulated at the demodulator (44) such that the demodulated data is used for controlling the train.

[0074] The data communication of the above procedure maintains a completely integrated synchronization between the on-board antenna (40) and the K-Balise (50) so as to secure the accurate data transfer.

[0075] Also, the analysis device (55) of the K-Balise (50) analyses the system performance of the K-Balise (50) by itself and stores and maintains the operation records.

[0076] FIG. 3 is a drawing for illustrating the target distance controller (23) as an element of the main device (2) of the present invention. As shown in FIG. 3, the target distance controller (23) includes a microprocessor (23a), a beacon information DB (23b), and a decoder (23c). Here, the microprocessor (23a) receives various information from the speed analyzer (21), the dynamic frequency discriminator (22), the GPS receiver (27), the beacon information DB (23b), and decoder (23c) and outputs the target distance information, target speed information, and the limit speed information. At this time, the microprocessor (23a) receives the movement distance information from the speed analyzer (21), the current signal information from the dynamic frequency discriminator (22), the standard position information from the GPS receiver (27), the position information from the beacon information DB (23b), and the rail information from the decoder (23c) which decodes the dynamic frequency discriminated by the dynamic frequency discriminator (22) and performs calculations. Here, the beacon information DB (23b) includes the data representing the beacon condition for the discrimination of the train position and the ground signal (frequency signal).

[0077] Here, the standard position information is obtained by the GPS receiver, however, the standard position can be preferably set by the combination of the position information combination of the beacon, which can check the present position of the train, the K-Balise, and the speed detector and it is preferable to combine the information obtained from two or more devices of the beacon, the K-Balise, the speed detector, and the GPS receiver. This is to improve the reliability and security of the train operation in consideration of the breakdown or error occurrence conditions.

[0078] FIG. 4 is a drawing for illustrating a control system concept of the K-Balise. As shown in FIG. 4, the K-Balises are buried in a regular interval and several K-Balises are grouped and controlled by each sub-control system (61). Also, the plural sub-control systems (62) are consisted of the integral control system (62). Such system is a sequential control system controlled by sequence control of the train, such that the command of the integral control system (62) is transferred to the sub-control systems (61) and then the information is transmitted to the on-board equipment using the narrow space data communication between the K-Balise and the on-board antenna. There is a difference between the above described communication module and the wireless control system by the broadband data communication of the integral control system.

[0079] FIG. 5 is a graph showing curves for illustrating the operation controls of the conventional ATS and ATPS of the present invention. It is shown that the ATS operation control curve is controlled in stepwise manner, however, the ATPS operation control curve is controlled in a smooth parabolic form. The ATS is operated with 5 signal types for national railroad and 5 beacons are associated with each other per traction section in which the beacon is installed so as to limit the maximum speed of the train operation per traction section according to the frequency. At this time, the ATS is a method for controlling the speed below a predetermined speed for each traction section by the frequency according to

the signal of the beacon. Thus, the speed is controlled below the predetermined speed for each track section regardless of the brake characteristic, operation characteristic, and other ground characteristic of the train the ATS shows 5 current signal system for reducing the operation speed of the train below the section limit speed.

[0080] The object of the ATPS of the present invention is to stop the train automatically by calculating, recognizing, and detecting the distance-to-go with the ATS. Particularly, the ATPS can increase the rail capacitance by controlling the distance-to-go using the ground information and freely adjusting the speed of each track section according to the frequency in consideration of the ground information as well as the on-board information such as the brake characteristic and the operation characteristic of the train so as to reduce the operation time. Accordingly, it is possible to smoothly control to stop the train operation.

Embodiment

[0081] The ATPS of the present invention is to speedup the railroad and release the bottleneck effect. The ATPS can use both the conventional 3-5 current time section and the ATS section and be adapted to the branch line and the main line so as to improve the security. Also, it is possible to reduce the operation time by adjusting the blockade section and the speed. The ATPS can be adopted for the high-speed train operation and secures the security and reliability with the accurate speed control.

[0082] The ATPS of the present invention is very economic because it can use the conventional railroad as it was. The ATPS shows the performance of 12 ms, in view of the maximum available communication time, at the train speed of 200 km/h, when the size of the K-Balise is 60 cm×30 cm such that it is preferred to design the on-board antenna referencing to such value. The available communication distance is determined by the size and the relative angle of each antenna of the K-Balise and is preferably performed in 1 m.

[0083] The modulation scheme selectively used one of the FSK, ASK, and PSK.

[0084] In this case, assuming that the constant oscillation frequency (carrier frequency) is in the range of 50 Khz to 1 Mhz, the data modulation is shown as frequency modulation and amplitude modulation and the communication speed shows the performance of maximum 50 Kbps in the speed of $\frac{1}{3}$ of the carrier frequency. This shows the possibility of adjustment to improve the communication speed through the adjustment of the oscillation range of the constant oscillation frequency.

[0085] Accordingly, the ATPS of the present invention can obtain the efficient operation control curve as adopting the Euro-Balise using the K-Balise without exchanging the convention railroad and it is possible to combine the ATS and ATP functions without exchanging the conventional ATS ground section through the combination of the K-Balise and the on-board antenna. Especially, the operation train to which the present invention is adopted to, can be the ATP system-mounted train, the high speed running train (KTX), the ATS-1 (point control type) and ATS-2 (speed detection type) type train running on the conventional railroad.

[0086] Although preferred embodiments of the present invention have been described in detail hereinabove, it

should be clearly understood that many variations and/or modifications of the basic inventive concepts herein taught which may appear to those skilled in the art will stall fall within the spirit and scope of the present invention, s defined in the appended claims.

INDUSTRIAL APPLICABILITY

[0087] The ATPS of the present invention provides the on-board operation information and has the auxiliary operation function so as to decrease the costs for the train signal control system field and improve the stability and accuracy of the train control, resulting in high utilization.

[0088] The ATPS of the present invention utilizes the data communication of electric source free method such that it is possible to secure the high security and reliability during the high-speed communication through the frequency bands.

What is claimed is:

1. An automatic train protection stop device for controlling the train using data communication, comprising:

an on-board equipment including a main device having a plurality of circuits for implementing an ATS function and an ATP function, an on-board antenna integrated with a on-board coil and an oscillator, a rotary type speed detector connected to a shaft of wheel, an operation information displayer providing speed information, ground information, and operation information, a operation switch for selecting an operation mode, a train controller for controlling a brake of the train, and a communication module for transmitting on-board information and ground information to an central control system and receiving radio commands from the central control system; and

a ground equipment including a K-Balise for transferring the ground information using an ATS member connected to a track occupancy detector through narrow space data communication, and a program part for inputting ground information data to the K-Balise.

2. The automatic train protection stop device of claim 1, wherein the main device includes:

a speed analyzer for converting an output of the speed detector into an actual speed;

a self-applying frequency discriminator having a function of discriminating resonant frequency generated by dynamic reaction of an ATS beacon and an on-ground antenna and constantly providing the self-applying frequency and discriminated current time information;

a target distance controller for receiving a corresponding section information (current signal information and rail information) when the on-board antenna approaches the ground K-Balise and train position and movement distance information so as to constantly calculate and provide a target distance and speed and a secure running speed of the train;

an operation controller for controlling all of the operations, providing information concerned to the operation, selecting an operation mode, setting a wheel diameter, communicating with the exterior device, and monitoring a speed calculation function of the speed analyzer;

an output controller for outputting the speed and current ATS information and contact point information for controlling excessive speed of the train on the basis of the ATP limit speed; and

an electric source converter for changing the electric source of the train into the electric source of the main device.

3. The automatic train protection stop device of claim 2, wherein the main device includes a GPS receiver for providing position information of the train using GPS.

4. The automatic train protection stop device of claim 2, wherein the main device includes an information recoding device for recoding and providing fixed and variable information of corresponding sections.

5. The automatic train protection stop device of claim 2, wherein the main device includes an interface card which receives and processes international or intercontinental ground signals (track circuit signals) so as to provided the processed information and enables an internal or intercontinental train control between nations and continents of which signal standards.

6. The automatic train protection stop device of claim 2, wherein the target distance controller includes:

a microprocessor for receiving various ground signals on the train and calculates the target distance information, target speed information, and limit speed information;

an beacon information DB having beacon information; and

a decoder for decoding the self-applying frequency discriminated by the self-applying frequency discriminator.

7. The automatic train protection stop device of claim 1, wherein the on-board antenna integrates the on-board member coil and the oscillator, outputs frequency and voltage variation signals, and transmits the ground information on the tract section by establishing a data communication network when approaching the K-Balise.

8. The automatic train protection stop device of claim 1, wherein the K-Balise modulates the stored information by establishing the data communication network when the on-board antenna being approached and transmits the modulated information to the main device.

9. The automatic train protection stop device of claim 1, wherein the on-board antenna includes a demodulator having a first and a second coils (L1, L2) so as to generate a maximum output at the resonant frequency by connecting an output of a power amplifier and a capacitance (C1) to the first coil, enable to constantly oscillate by connecting the second coil to an input of the amplifier, and decoding the data transmitted at the K-Balise.

10. The automatic train protection stop device of claim 1, wherein the K-Balise includes a modulator, a micro control unit, a cluck generator, and a storage device for forming a parallel resonant circuit of L3 and C3 so as to be oscillated by the frequency close to the oscillate frequency of the on-board antenna; and an analysis device for self-testing the operation state of the K-Balise and storing/maintaining the operation records.

11. The automatic train protection stop device of claim 1, wherein the operation information displayer includes a voice output alarm device for providing, in voice alarm, the operator with the speed information and ground information

in the corresponding section using the GPS receiver and information recording device.

12. The automatic train protection stop device of claim 1, wherein the communication module communicates the information with the integral control system through a broadband data communication.

13. The automatic train protection stop device of claim 1, wherein the information recording device is a USB card or a flash memory card to/from which the fixed and variable information on the ground section can be written/read.

14. The automatic train protection stop device of claim 4 or claim 13, wherein the fixed information of the ground information recorded in the information recording device is the data including the rail condition such as a position of the beacon, geometrical situation, and the like; and the variable information of the ground information is the data including the information changing on and off such as a rail working area and movement of the rail work.

* * * * *