



(22) Date de dépôt/Filing Date: 2002/04/30  
(41) Mise à la disp. pub./Open to Public Insp.: 2003/10/30

(51) Cl.Int.<sup>7</sup>/Int.Cl.<sup>7</sup> B65F 3/20, B65F 3/28

(71) Demandeur/Applicant:  
WITTKER INC., CA

(72) Inventeur/Inventor:  
HUANG, SIMON, CA

(74) Agent: ANISSIMOFF & ASSOCIATES

(54) Titre : CAMION A ORDURES EQUIPE D'UN DISPOSITIF DE TASSEMENT PENDULAIRE ET D'UN SYSTEME D'EVACUATION DES ORDURES  
(54) Title: REFUSE COLLECTION VEHICLE WITH PENDULAR PACKING DEVICE AND REFUSE EJECTION SYSTEM

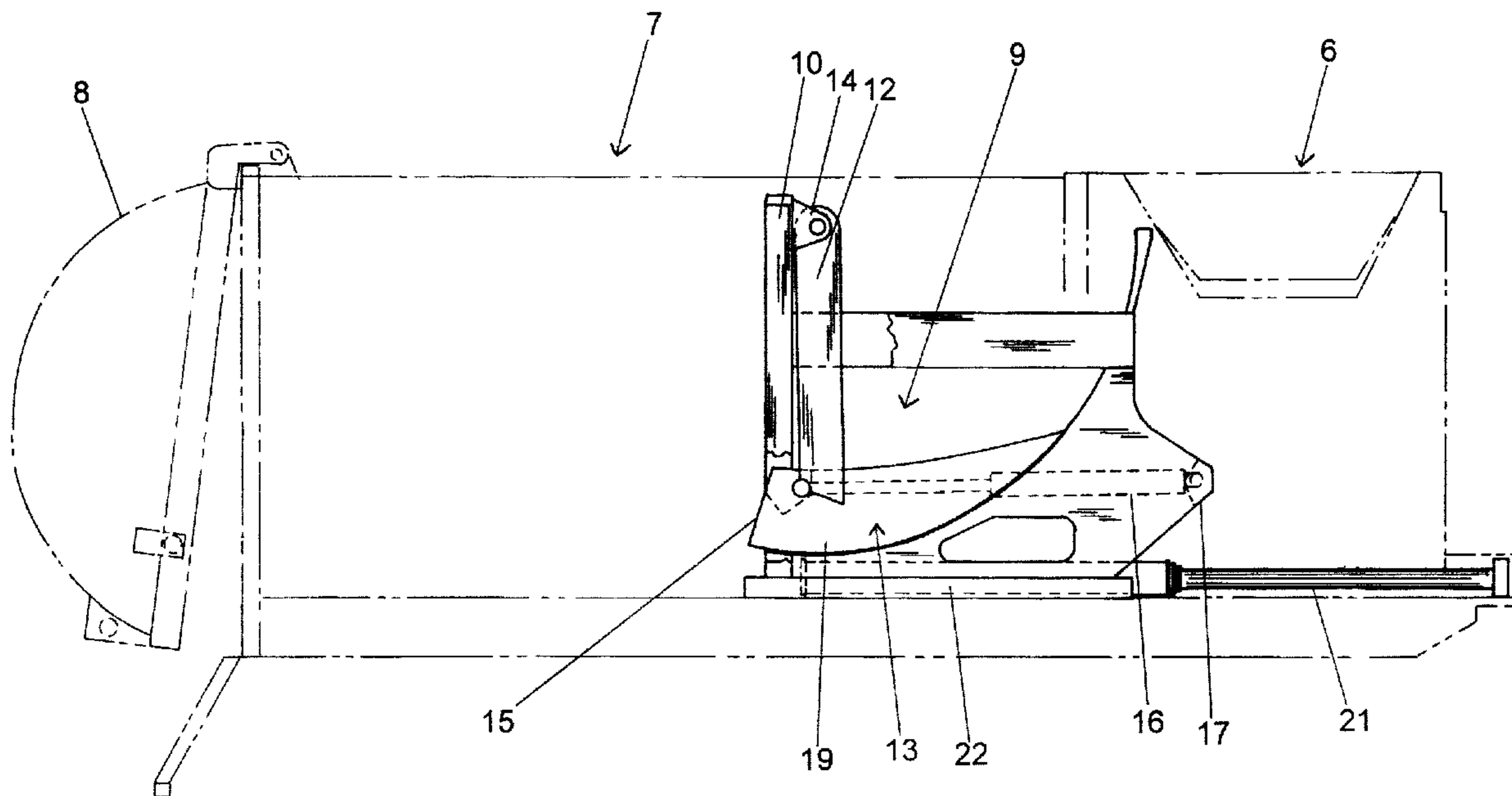

(57) Abrégé/Abstract:

A refuse collection vehicle having a vehicle chassis including a vehicle cab and frame with a vehicle body mounted on top of the frame. The vehicle body has a front receiving hopper separated from a rear storage compartment by means of a partition having an aperture for passage of refuse. A pendular packing device having a refuse engaging face is pivotally mounted within the receiving hopper and arcuately swings to rapidly transfer refuse through the aperture. In order to empty the storage compartment, a rear door is opened to permit egress of refuse and the partition moves longitudinally along the vehicle body to displace refuse out of the storage compartment.

**Abstract**

A refuse collection vehicle having a vehicle chassis including a vehicle cab and frame with a vehicle body mounted on top of the frame. The vehicle body has a front receiving hopper separated from a rear storage compartment by means of a partition having an aperture for passage of refuse. A pendular packing device having a refuse engaging face is pivotally mounted within the receiving hopper and arcuately swings to rapidly transfer refuse through the aperture. In order to empty the storage compartment, a rear door is opened to permit egress of refuse and the partition moves longitudinally along the vehicle body to displace refuse out of the storage compartment.

**TITLE: REFUSE COLLECTION VEHICLE WITH PENDULAR  
PACKING DEVICE AND REFUSE EJECTION SYSTEM**

**INVENTOR: SIMON HUANG**

**BACKGROUND OF THE INVENTION**

**5 Field of the Invention**

The invention relates to refuse collection vehicles, particularly refuse collection vehicles equipped with pendular packing devices capable of ejecting stored refuse from the rear of the vehicle body.

**Description of the Prior Art**

10 Refuse collection vehicles normally have a vehicle chassis consisting of a frame with front and rear sets of wheels, a cab for housing the vehicle operator, and an engine for powering the vehicle's hydraulic system and rear wheels. The cab is mounted atop the frame at the front end and a vehicle body is located rearward of the cab and longitudinally aligned with  
15 the frame.

The vehicle body has a receiving hopper into which refuse is deposited. The receiving hopper has a partition separating it from a

---

storage compartment immediately rearward of the receiving hopper. The storage compartment normally includes a roof, two sides, a floor, and at least one rear door that may be opened to permit egress of stored refuse. The partition includes an aperture for passage of refuse from the receiving  
5 hopper to the storage compartment.

Refuse may be transferred through the aperture in at least two ways. One way is by longitudinally sliding a packing device positioned at the front of the receiving hopper towards the rear of the vehicle so that a refuse engaging face of the packing device pushes the refuse through the  
10 aperture into the storage compartment. Another way is by using a pendular packing device pivotally mounted within the receiving hopper that arcuately swings from a raised position to a lower position towards the rear of the receiving hopper. The receiving hopper floor is normally curved to correspond to the arc of the pendular packing device and a  
15 refuse engaging face of the packing device transfers the refuse through the aperture. Since the transfer of refuse is aided by gravity and since this type of packing device is typically equipped with low-volume, fast-acting hydraulic cylinders, refuse can be transferred to the storage compartment at a faster rate than with a conventional sliding packing device, which  
20 usually increases the overall efficiency of refuse collection. Also, sliding



packing devices have load bearing surfaces in contact with one another that are prone to wear and accordingly have increased maintenance cost as compared with pendular packing devices.

To empty waste from the storage compartment, for example at a landfill site, refuse collection vehicles are typically equipped with a vehicle body tilting mechanism. The vehicle body is normally attached to the rear of the vehicle frame by means of a hinge and a hydraulic lifting cylinder is provided to raise the front end of the vehicle body. Refuse is then permitted to downwardly slide from the storage compartment through the open rear door. Raising the vehicle body places the vehicle in a precarious and unsafe position, especially on the uneven terrain frequently encountered at a landfill site. Also, there is a risk of contact with overhead obstacles, such as electrical wires. The lifting cylinder is expensive and it is time consuming to raise the vehicle body.

To address these concerns, some refuse collection vehicles have recently been equipped with refuse ejection systems. The refuse ejection system employs a sliding packing device typically powered by a pair of telescoping hydraulic cylinders. To eject the refuse, the telescoping cylinders extend the packing device, which engages the rear partition of the receiving hopper and longitudinally slides the partition towards the rear

of the vehicle. Refuse is thereby displaced out through the open rear door, obviating the need for the vehicle body tilting mechanism.

Conventional refuse ejection systems employ the sliding packing device, with the inherent wear problems previously described. In addition,  
5 a pair of telescoping cylinders is typically provided, which increases vehicle cost and maintenance. Due primarily to their large volume, telescoping cylinders are inherently slow acting as compared with low volume cylinders, exacerbating the problem of slow transfer of refuse from the receiving hopper to the storage compartment normally experienced  
10 with sliding packing devices.

To increase collection efficiency, refuse vehicles are sometimes equipped with automated container loaders for depositing refuse within the vehicle body. Though these devices may increase the rate at which individual containers may be loaded, the overall collection efficiency is  
15 often limited by how quickly the deposited refuse can be transferred from the receiving hopper to the storage compartment.

The present invention seeks to overcome the disadvantages of sliding packing devices and vehicle body tilting mechanisms by providing a low cost, minimal maintenance system for rapidly transferring refuse from the

---

receiving hopper to the storage compartment of a refuse collection vehicle that may be advantageously employed in conjunction with an automated container loader to increase the overall efficiency of refuse collection.

### **SUMMARY OF THE INVENTION**

5 According to an aspect of the invention, there is provided a refuse collection vehicle body having a rear and a front. The vehicle body has at its rear a refuse storage compartment having a rear door operable to open to permit egress of refuse and at its front a refuse receiving hopper. The receiving hopper has a substantially vertical rear partition located forward  
10 of the storage compartment and separating the receiving hopper from the storage compartment. The rear partition has an aperture for passage of the refuse to the storage compartment. A pendular packing device is pivotally mounted within the receiving hopper. The packing device has a refuse engaging face and is operable to arcuately swing, thereby  
15 transferring the refuse to the storage compartment through the aperture. The rear partition is operable to longitudinally slide toward the rear door of the storage compartment, thereby displacing the refuse in the storage compartment out through the door.

---



According to another aspect of the invention, there is provided a refuse collection vehicle comprising: a vehicle frame having front and rear sets of road engaging wheels mounted thereunder and motive means for rotating at least one of the sets of wheels; a vehicle cab mounted on the vehicle frame; and, a vehicle body having a rear and a front longitudinally mounted on the vehicle frame rearward of the vehicle cab. The vehicle body has at its rear a refuse storage compartment having a rear door operable to open to permit egress of refuse and at its front a refuse receiving hopper. The receiving hopper has a substantially vertical rear partition located forward of the storage compartment and separating the receiving hopper from the storage compartment. The rear partition has an aperture for passage of the refuse to the storage compartment. A pendular packing device is pivotally mounted within the receiving hopper. The packing device has a refuse engaging face and is operable to arcuately swing, thereby transferring the refuse to the storage compartment through the aperture. The rear partition is operable to longitudinally slide toward the rear door of the storage compartment, thereby displacing the refuse in the storage compartment out through the door.



According to yet another aspect of the invention, there is provided a refuse collection vehicle comprising: a vehicle frame having front and rear sets of road engaging wheels mounted thereunder and motive means for rotating at least one of the sets of wheels; a vehicle cab mounted on the vehicle frame; and, a vehicle body having a rear and a front longitudinally mounted on the vehicle frame rearward of the vehicle cab. The vehicle body has at its rear a refuse storage compartment having a rear door operable to open to permit egress of refuse and at its front a refuse receiving hopper. The receiving hopper has a substantially vertical rear partition with substantially the same width and height as the interior of the storage compartment located forward of the storage compartment and separating the receiving hopper from the storage compartment. The rear partition has an aperture for passage of the refuse to the storage compartment. A pendular packing device is pivotally mounted within the receiving hopper and has a refuse engaging face. The device is operable to arcuately swing, thereby transferring the refuse to the storage compartment through the aperture and has at least one swing member having an upper end and a lower end. The upper end of the swing member is pivotally mounted at substantially the top of the rear partition. The refuse engaging face is attached to the lower end of the swing member and adapted to block the aperture to prevent passage of the

refuse from the storage compartment to the receiving hopper. The aperture is located at substantially the bottom of the rear partition. The receiving hopper is operable to longitudinally slide toward the rear door of the storage compartment, thereby displacing the refuse in the storage  
5 compartment out through the door.

Further features of the invention will be described or will become apparent in the course of the following detailed description.

#### **BRIEF DESCRIPTION OF THE DRAWINGS**

In order that the invention may be more clearly understood, a preferred  
10 embodiment thereof will now be described in detail by way of example, with reference to the accompanying drawings, in which:

Fig 1 is a perspective view of a refuse vehicle.

Fig 2 is a perspective view of a refuse vehicle body with a pendular packing device in the raised position.

15 Fig 3 is a perspective view of a refuse vehicle body with a pendular packing device in the lowered position.

Fig 4 is a perspective view of a refuse receiving hopper with a pendular packing device.

Fig 5 is a side view of a first embodiment of a refuse vehicle body during ejection of refuse.

5 Fig 6 is a perspective view of a first embodiment of a refuse vehicle body during ejection of refuse.

Fig 7 is a side view of a second embodiment of a refuse vehicle body during ejection of refuse.

10 Fig 8 is a perspective view of a refuse collection vehicle with an automated container loader adjacent the side of the vehicle.

### **PREFERRED EMBODIMENT**

A refuse collection vehicle is generally illustrated in Fig 1. The vehicle chassis includes a frame 1 having front and rear sets of wheels 2 and 3 and a vehicle cab 4 at the front of the frame. The cab 4 houses the vehicle operator and vehicle controls (not shown). An engine (not shown) is typically mounted to the frame 1 at the front of the vehicle for powering the vehicle hydraulic system and for rotating at least one of the sets of rear wheels 3. A vehicle body 5 is mounted on top of the frame 1



rearward of the cab 4. The vehicle body 5 includes a receiving hopper 6 into which refuse is deposited for subsequent transfer to a storage compartment 7. The receiving hopper 6 is shown with openings in its top and side through which refuse may be deposited by an automated container loader (not shown). A refuse collection vehicle may also have openings in the side of the receiving hopper 6 (not shown) to permit manual side loading of refuse from residential waste containers. The storage compartment 7 has at least one rear door 8 that is operable to open to permit egress of stored refuse, such as at a landfill site, preferably using hydraulic cylinders.

Referring to Figs 2, 3 and 4, a pendular packing device 9 is shown within the receiving hopper 6. The receiving hopper 6 has a rear partition 10 that separates the receiving hopper from the storage compartment 7. The partition 10 has an aperture 11 for passage of refuse from the receiving hopper 6 to the storage compartment 7. The pendular packing device 9 is operable to arcuately swing, thereby transferring refuse through the aperture 11.

The packing device 9 includes a pair of swing members 12 and a refuse transfer head 13. The upper end of each swing member 12 is pivotally attached to the vehicle body 5, for example, by means of a

bracket **14** at substantially the top of the rear partition **10**. The bracket **14** may include bearings (not shown) to facilitate pivoting movement of the swing member **12**. The lower end of each swing member **12** is attached to the refuse transfer head **13**, which has a refuse engaging face **15**  
5 oriented towards the rear of the vehicle. A hydraulic cylinder **16** is pivotally attached at one end to each swing member **12**. The opposite end is attached to a portion of the vehicle body **5**, such as a horizontal cross member **17** at the front of the receiving hopper **6**. To operate the packing device **9**, the cylinders **16** are extended, causing the refuse  
10 engaging face **15** to arcuately swing downwardly and rearwardly, thereby transferring refuse resting on the receiving hopper floor **18** into the storage compartment **7** through the aperture **11**. In order that the majority of refuse is removed from the receiving hopper **6**, the transfer head **13** includes side **19** and top **20** surfaces to prevent refuse from falling behind  
15 the face **15** and the receiving hopper floor **18** is curved to correspond with the arc followed by the packing device **9**. Retraction of the cylinders **16** causes the transfer head **13** to swing in the opposite direction, thereby readying the receiving hopper **6** for the next deposit of refuse.

To empty the contents of the storage compartment **7**, for example at a  
20 landfill site, a refuse ejection system may be employed where the rear

door **8** is opened and the rear partition **10** is moved longitudinally towards the rear of the vehicle body **5**. The movement of the rear partition **10** causes the volume of the storage compartment **7** to decrease, thereby displacing refuse from the storage compartment out through the open rear door **8** and eliminating the need for a vehicle body tilting mechanism.

Referring to Figs 5 and 6, in a first embodiment the longitudinal movement is created by extension of a telescoping cylinder **21** that may be attached, for example, at one end to the front of the vehicle body **5** and at the other end to the underside of the receiving hopper floor **18**. Rails **22** along the bottom of the receiving hopper **6** may be provided that correspond to slots (not shown) along the bottom of the storage compartment **7** and lubricated, for example by a low friction solid material such as Delrin™ or any other suitable material, to facilitate longitudinal sliding movement of the receiving hopper.

Referring to Fig 7, in a second embodiment both the cylinder **21** and rails **22** are attached to the underside of the rear partition and only the rear partition **10** slides. The partition **10** may, for example, abut against the rear face of an inwardly extending frame **23** along the sides of the vehicle body **5** and the brackets **14** may be attached to the front face of the inwardly extending frame near the top of the rear partition. The inwardly



extending frame may also be attached to the receiving hopper floor **18**. The rear partition **10** may therefore slide rearwardly independently of the remainder of the receiving hopper **6** in order to eject refuse from the storage compartment **7**.

5 To prevent refuse from passing back into the receiving hopper **6** through the aperture **11** upon sliding of the rear partition **10**, the packing device **9** may be placed in the lowered position so that the refuse engaging face **15** blocks the aperture. The packing device **9** then moves with the rear partition **10** as the entire receiving hopper **6** longitudinally  
10 slides along the vehicle body **5**, thereby preventing transfer of refuse back into the receiving hopper. Alternatively, a gate **24** may be provided to block the aperture **11**, which is especially useful in the second embodiment. The gate **24** may be, for example, hydraulically operated and designed to vertically slide along the rear partition **10**. The packing  
15 device **9** and gate **24** may also be advantageously employed cooperatively in either embodiment to prevent "spring back" of refuse from the storage compartment **7** to the receiving hopper **6** following each individual refuse transfer operation.

Turning to Fig 8, a refuse collection vehicle is shown with an  
20 automated container loader **25** adjacent the side of the receiving hopper **6**.

The automated container loader **25** shown is of a type used to retrieve curbside residential waste containers. An alternative type of automated container loader (not shown) may be positioned adjacent the front of the vehicle to retrieve a bulk commercial refuse container. Using the  
5 automated container loader **25**, a refuse container may be raised and downwardly tilted to deposit its contents through the top and/or side openings into the receiving hopper **6**. Automated container loaders are used to promote the efficiency of refuse vehicle operation by increasing collection speed while reducing labour requirements. The present  
10 invention may be advantageously employed in conjunction with an automated container loader to minimize the potential for a bottleneck in transferring refuse caused by an increase in refuse collection speed. As previously described, the present invention employs gravity and fast-acting hydraulic cylinders to rapidly transfer refuse from the receiving  
15 hopper **6** to the storage compartment **7** in a vehicle equipped with a refuse ejection system. This is in contrast to other vehicles equipped with refuse ejection systems that employ sliding packing devices utilizing a pair of telescoping cylinders, which are inherently slower to extend and more expensive to maintain than the simple cylinders employed in the present  
20 invention. The potential for increased efficiency afforded by the automated container loader **25** is accordingly realized in a vehicle

---

equipped with a refuse ejection system through the rapid refuse transfer provided by the pendular packing device 9.

From the foregoing, it will be seen that this invention is one well adapted to attain all the ends and objects hereinabove set forth together  
5 with other advantages which are obvious and which are inherent to the structure.

It will be understood that certain features and sub-combinations are of utility and may be employed without reference to other features and sub-combinations. This is contemplated by and is within the scope of the  
10 claims.

Since many possible embodiments may be made of the invention without departing from the scope thereof, it is to be understood that all matter herein set forth or shown in the accompanying drawings is to be interpreted as illustrative and not in a limiting sense.



## **CLAIMS**

Having described the invention, what is claimed is:

1. A refuse collection vehicle body having a rear and a front, comprising:

a refuse storage compartment at the rear of said vehicle body having a rear door operable to open to permit egress of refuse;

a refuse receiving hopper at the front of said vehicle body having a substantially vertical rear partition located forward of said storage compartment and separating said receiving hopper from said storage compartment, said rear partition having an aperture for passage of said refuse to said storage compartment;

a pendular packing means pivotally mounted within said receiving hopper having a refuse engaging face, said packing means operable to arcuately swing, thereby transferring said refuse to said storage compartment through said aperture;

said rear partition operable to longitudinally slide toward said rear door of said storage compartment, thereby displacing said refuse in said storage compartment out through said rear door.

2. The refuse collection vehicle body of claim 1, wherein said rear partition has substantially the same width and height as the interior of said storage compartment.
3. The refuse collection vehicle body of claim 2, wherein said packing means moves with said rear partition and said refuse engaging face blocks said aperture to prevent passage of said refuse from said storage compartment to said receiving hopper.
4. The refuse collection vehicle body of claim 3, wherein said packing means has at least one swing member having a lower end and an upper end, said refuse engaging face attached to the lower end of said swing member.
5. The refuse collection vehicle body of claim 4, wherein said upper end of said swing member is pivotally mounted at substantially the top of said rear partition.

6. The refuse collection vehicle body of claim 5, wherein said aperture is located at substantially the bottom of said rear partition.
  7. The refuse collection vehicle body of claim 6, wherein said packing means is operable by means of a hydraulic cylinder attached at one end to said vehicle body and at the opposite end to said swing member.
  8. The refuse collection vehicle body of claim 7, wherein said rear partition is operable by means of a hydraulic cylinder.
  9. The refuse collection vehicle body of claim 8, wherein said receiving hopper is operable to longitudinally slide toward said rear door of said storage compartment to displace said refuse in said storage compartment out through said rear door.
  10. The refuse collection vehicle body of claim 2, wherein said rear partition includes a refuse blocking gate, said gate operable to block said aperture to prevent transfer of said refuse from said storage compartment to said receiving hopper.
  11. The refuse collection vehicle body of claim 10, wherein said aperture is located at substantially the bottom of said rear partition.
-



12. The refuse collection vehicle body of claim 11, wherein said rear partition is operable by means of a hydraulic cylinder.
13. The refuse collection vehicle body of claim 12, wherein said receiving hopper is operable to longitudinally slide toward said rear door of said storage compartment to displace said refuse in said storage compartment out through said rear door.
14. A refuse collection vehicle comprising:
  - a vehicle frame having front and rear sets of road engaging wheels mounted thereunder and motive means for rotating at least one of said sets of wheels;
  - a vehicle cab mounted on said vehicle frame;
  - a vehicle body having a rear and a front longitudinally mounted on said vehicle frame rearward of said vehicle cab, said vehicle body comprising:
    - a refuse storage compartment at the rear of said vehicle body having a rear door operable to open to permit egress of refuse;

a refuse receiving hopper at the front of said vehicle body having a substantially vertical rear partition located forward of said storage compartment and separating said receiving hopper from said storage compartment, said rear partition having an aperture for passage of said refuse to said storage compartment;

a pendular packing means pivotally mounted within said receiving hopper having a refuse engaging face, said packing means operable to arcuately swing, thereby transferring said refuse to said storage compartment through said aperture;

said rear partition operable to longitudinally slide toward said rear door of said storage compartment, thereby displacing said refuse in said storage compartment out through said rear door.

15. The refuse collection vehicle of claim 14, wherein said receiving hopper includes a top opening for receiving said refuse.
16. The refuse collection vehicle of claim 15, wherein said vehicle includes an automated container loader for raising a refuse

container adjacent the front of said vehicle and downwardly depositing said refuse into said receiving hopper.

17. The refuse collection vehicle of claim 15, wherein said vehicle includes an automated container loader for raising a refuse container adjacent the side of said vehicle and downwardly depositing said refuse into said receiving hopper.

18. The refuse collection vehicle of claim 14, wherein said receiving hopper includes a side opening for receiving said refuse.

19. The refuse collection vehicle of claim 18, wherein said vehicle includes an automated container loader for raising a refuse container adjacent the side of said vehicle and downwardly depositing said refuse into said receiving hopper.

20. A refuse collection vehicle comprising:

a vehicle frame having front and rear sets of road engaging wheels mounted thereunder and motive means for rotating at least one of said sets of wheels;

a vehicle cab mounted on said vehicle frame;



a vehicle body having a rear and a front longitudinally mounted on said vehicle frame rearward of said vehicle cab, said vehicle body comprising:

a refuse storage compartment at the rear of said vehicle body having a rear door operable to open to permit egress of refuse;

a refuse receiving hopper at the front of said vehicle body having a substantially vertical rear partition with substantially the same width and height as the interior of said storage compartment located forward of said storage compartment and separating said receiving hopper from said storage compartment, said rear partition having an aperture for passage of said refuse to said storage compartment;

a pendular packing means pivotally mounted within said receiving hopper having a refuse engaging face, said packing means operable to arcuately swing, thereby transferring said refuse to said storage compartment through said aperture and having at least one swing

member having an upper end and a lower end, said upper end of said swing member pivotally mounted at substantially the top of said rear partition, said refuse engaging face attached to the lower end of said swing member and adapted to block said aperture to prevent passage of said refuse from said storage compartment to said receiving hopper, said aperture located at substantially the bottom of said rear partition;

said receiving hopper operable to longitudinally slide toward said rear door of said storage compartment, thereby displacing said refuse in said storage compartment out through said rear door.

1/8

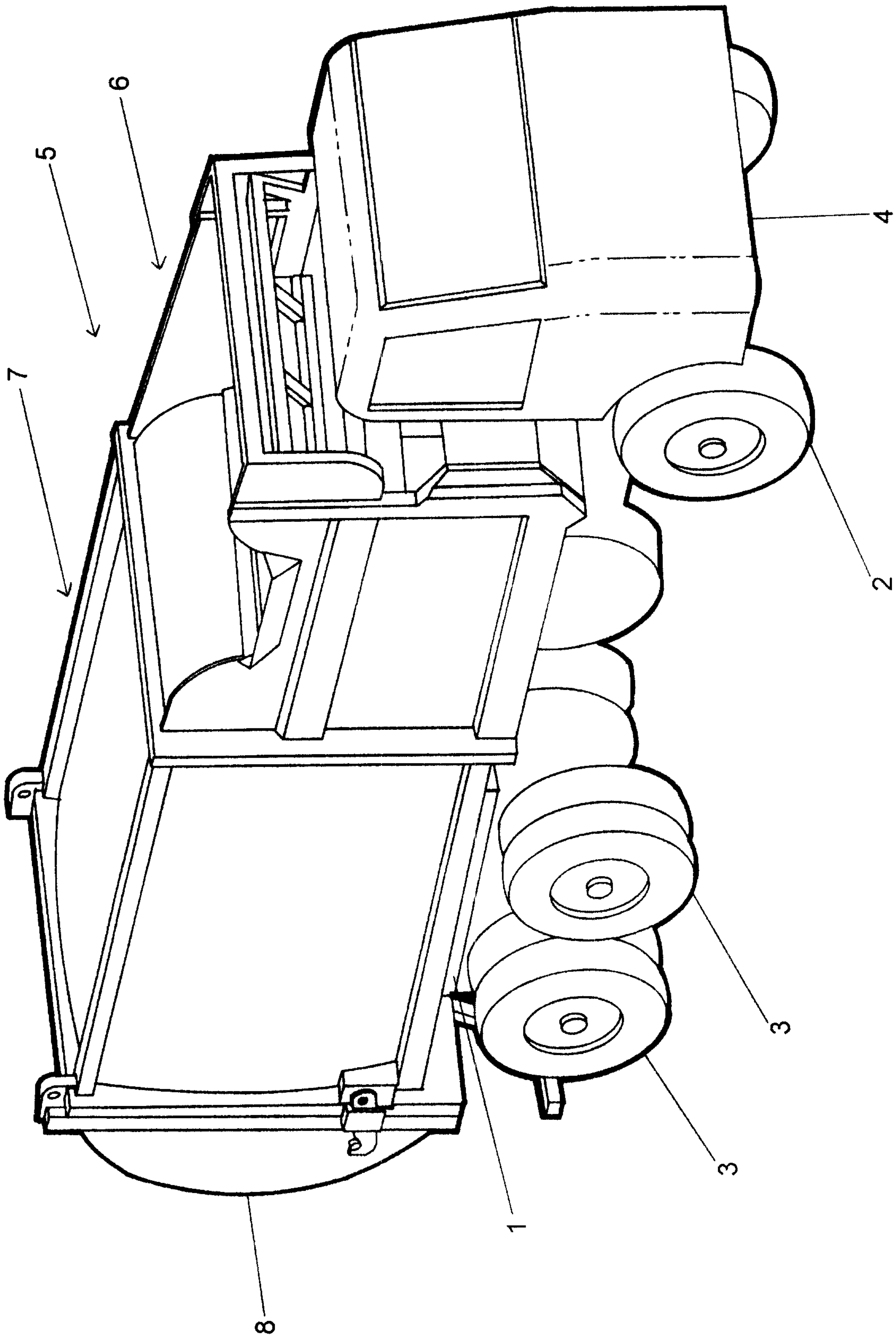

FIG. 1



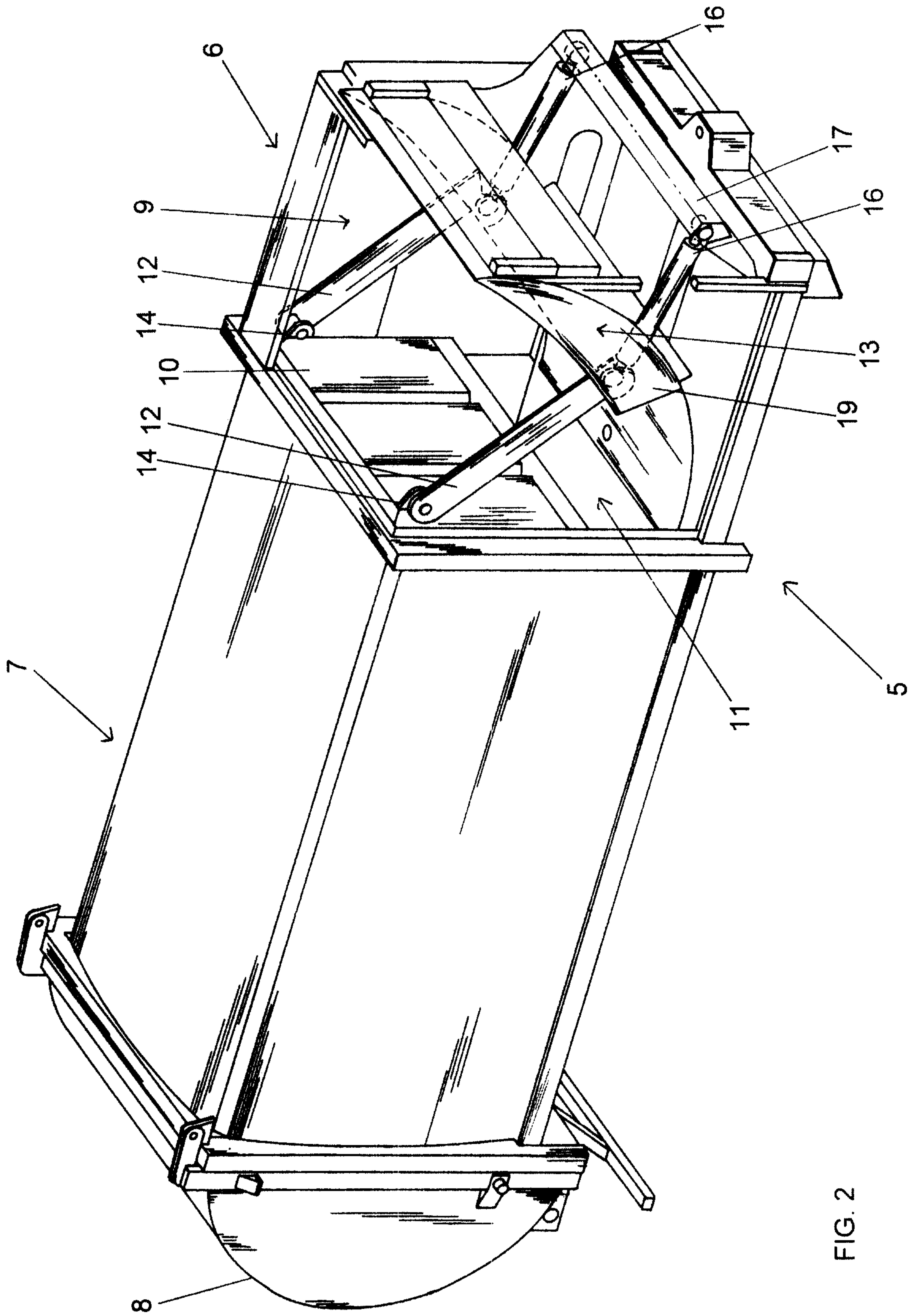

FIG. 2

3/8

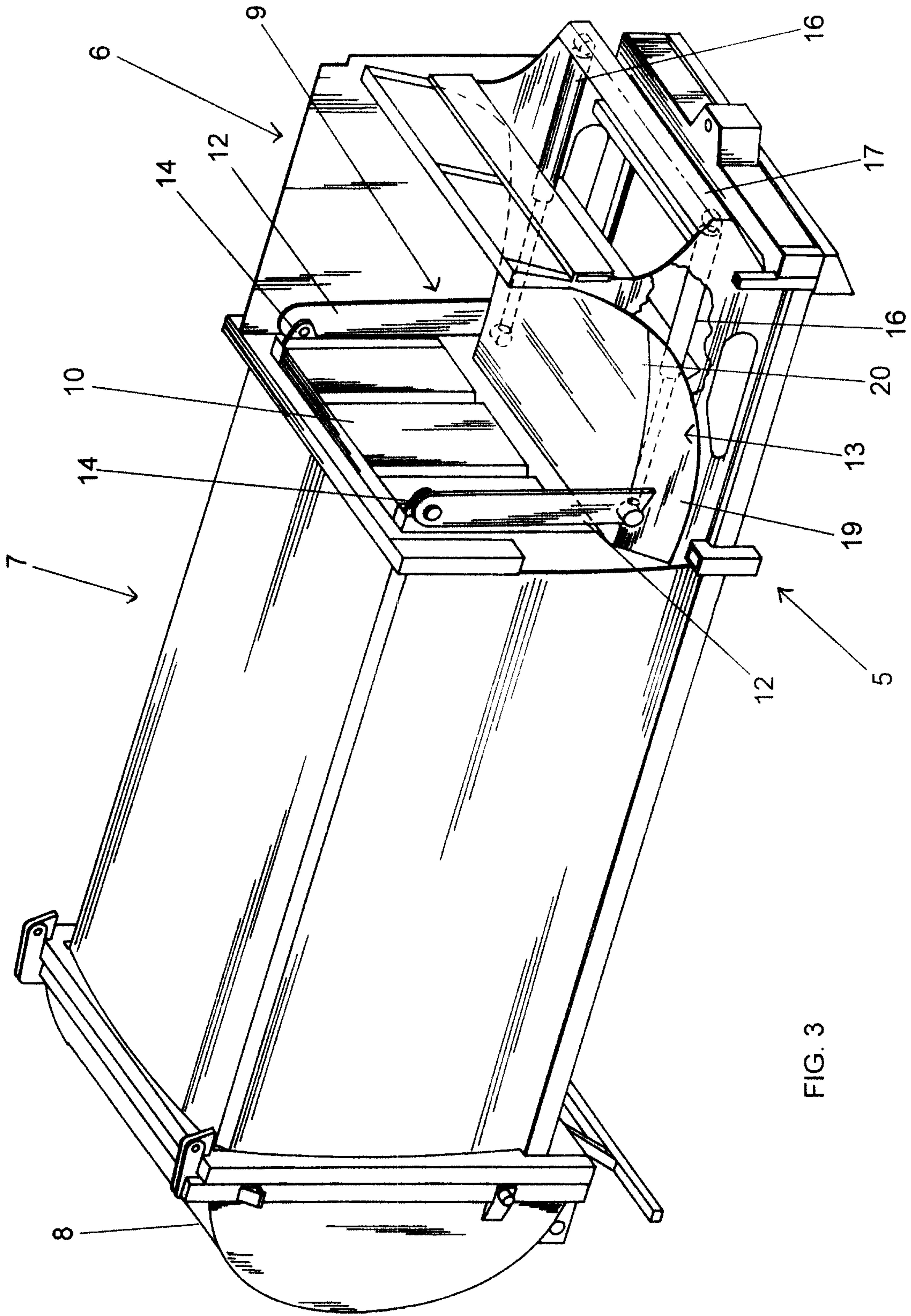

FIG. 3

4/8

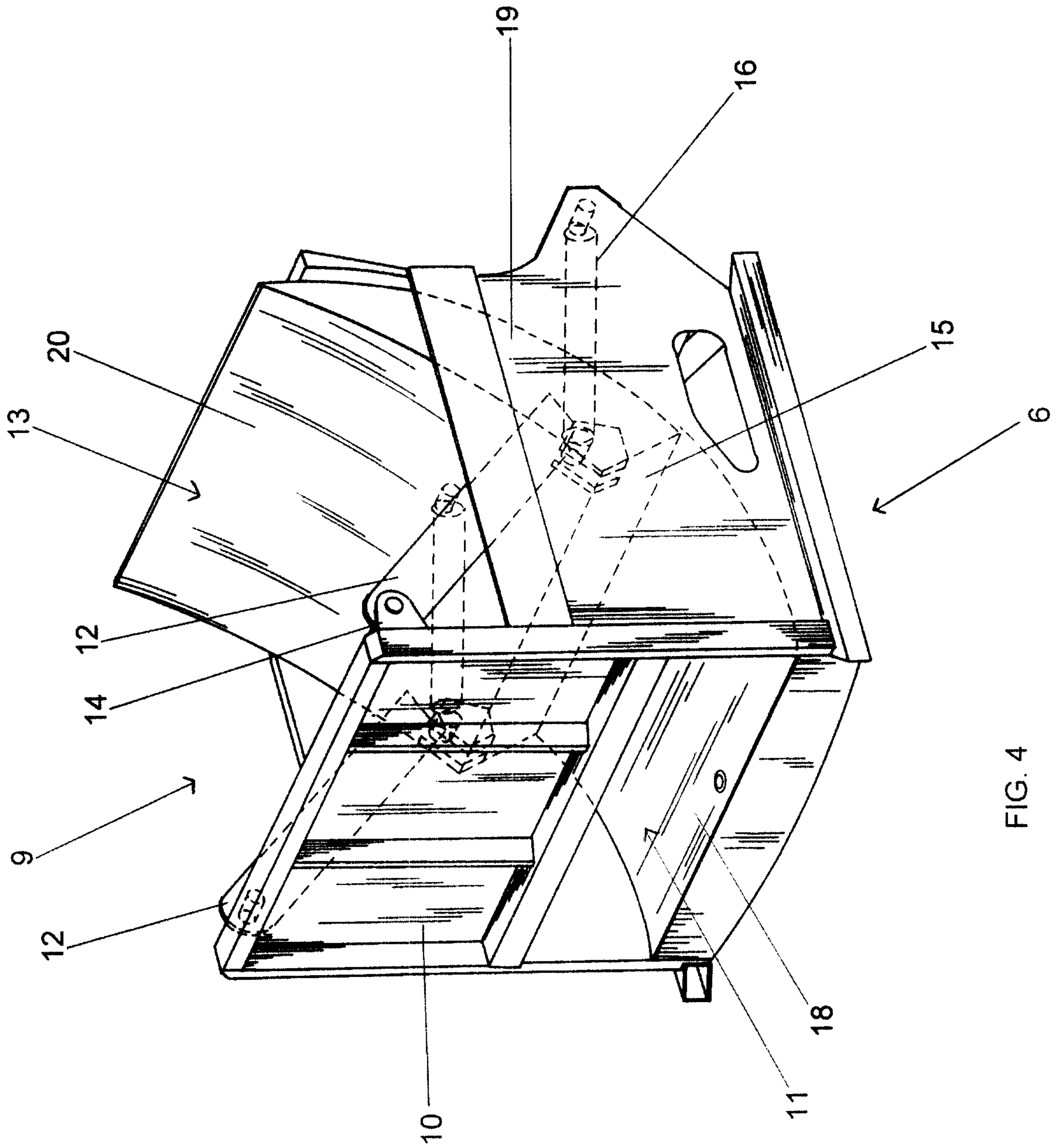

FIG. 4



5/8

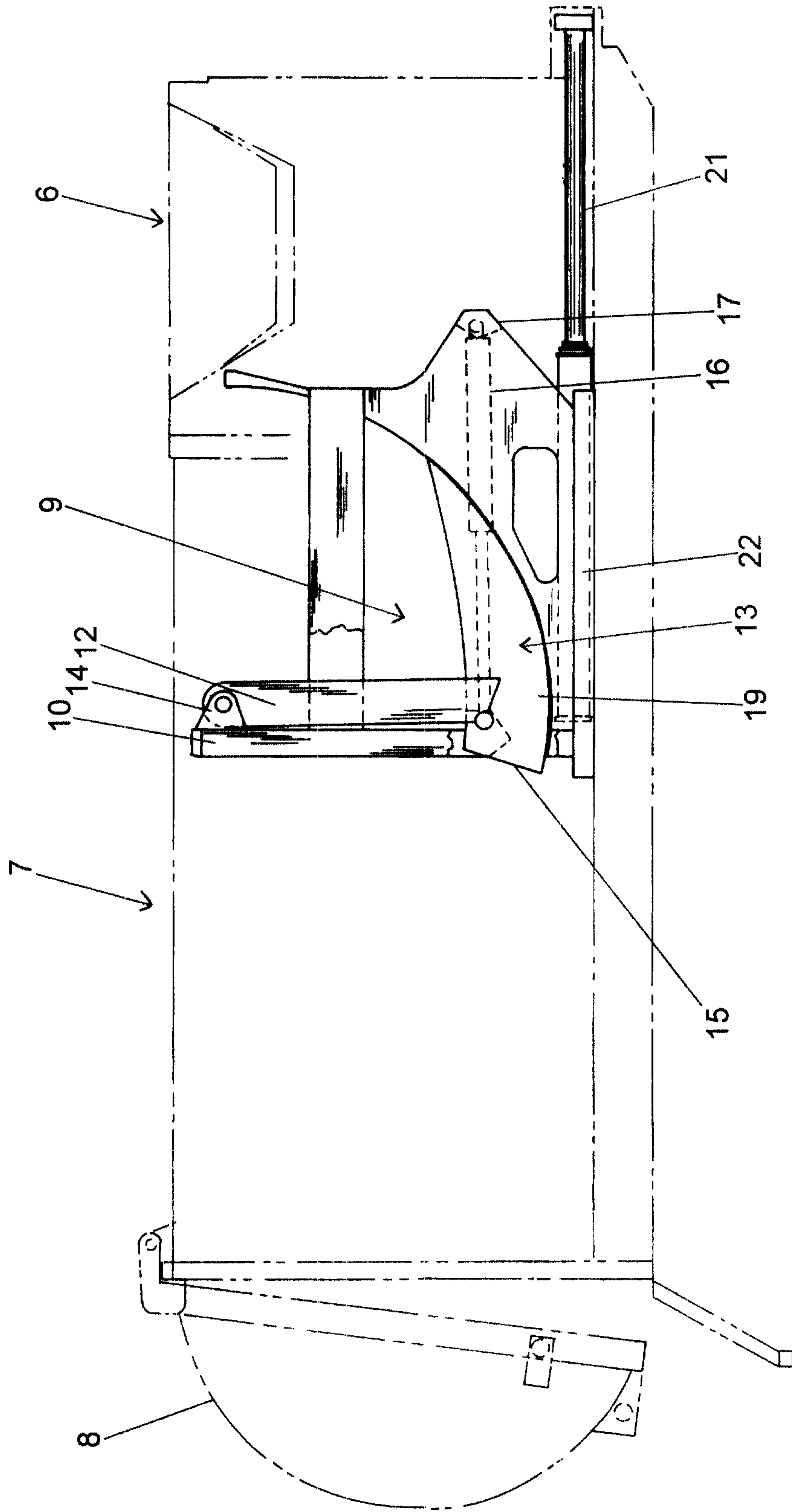

FIG. 5

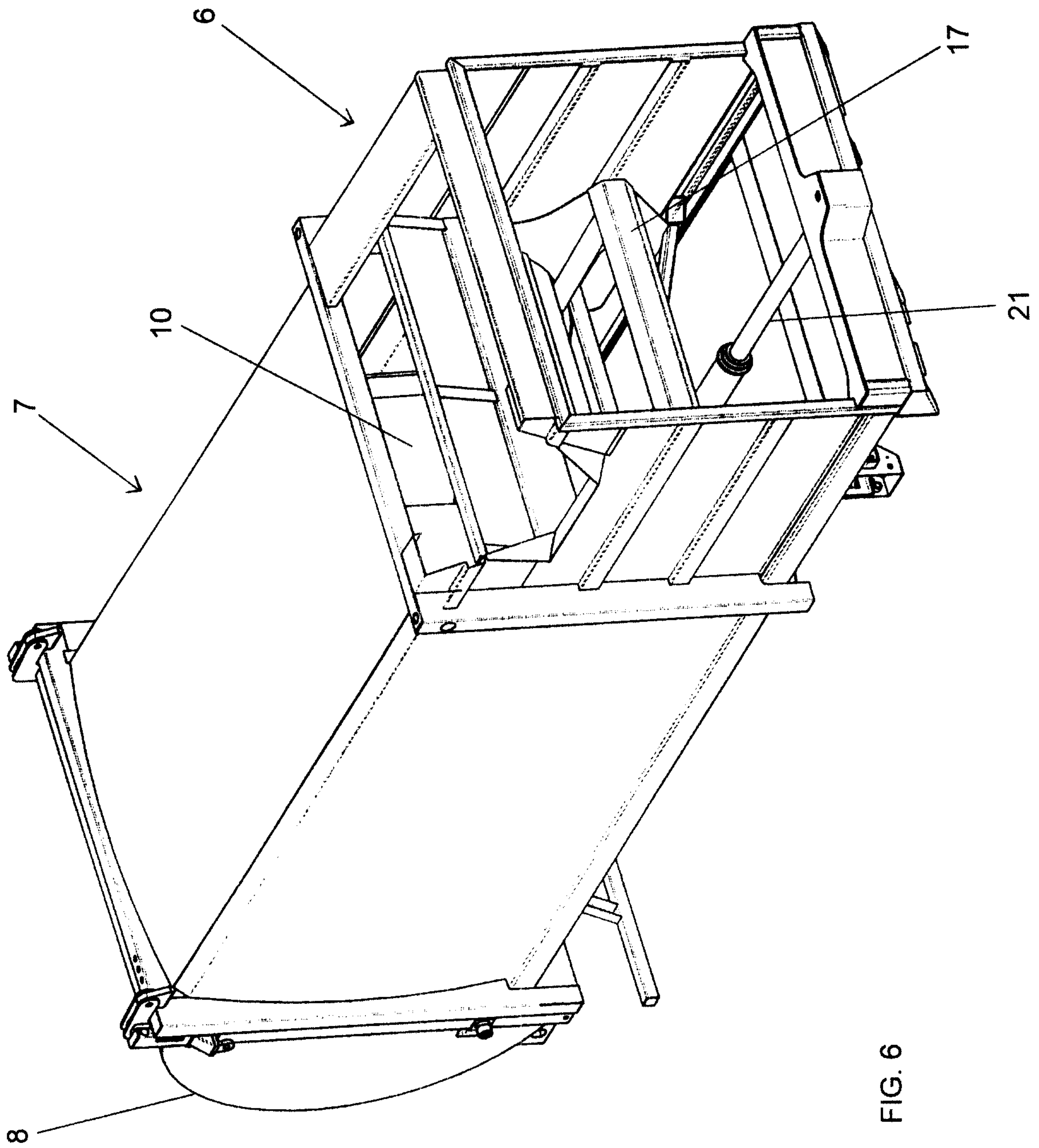

FIG. 6

718

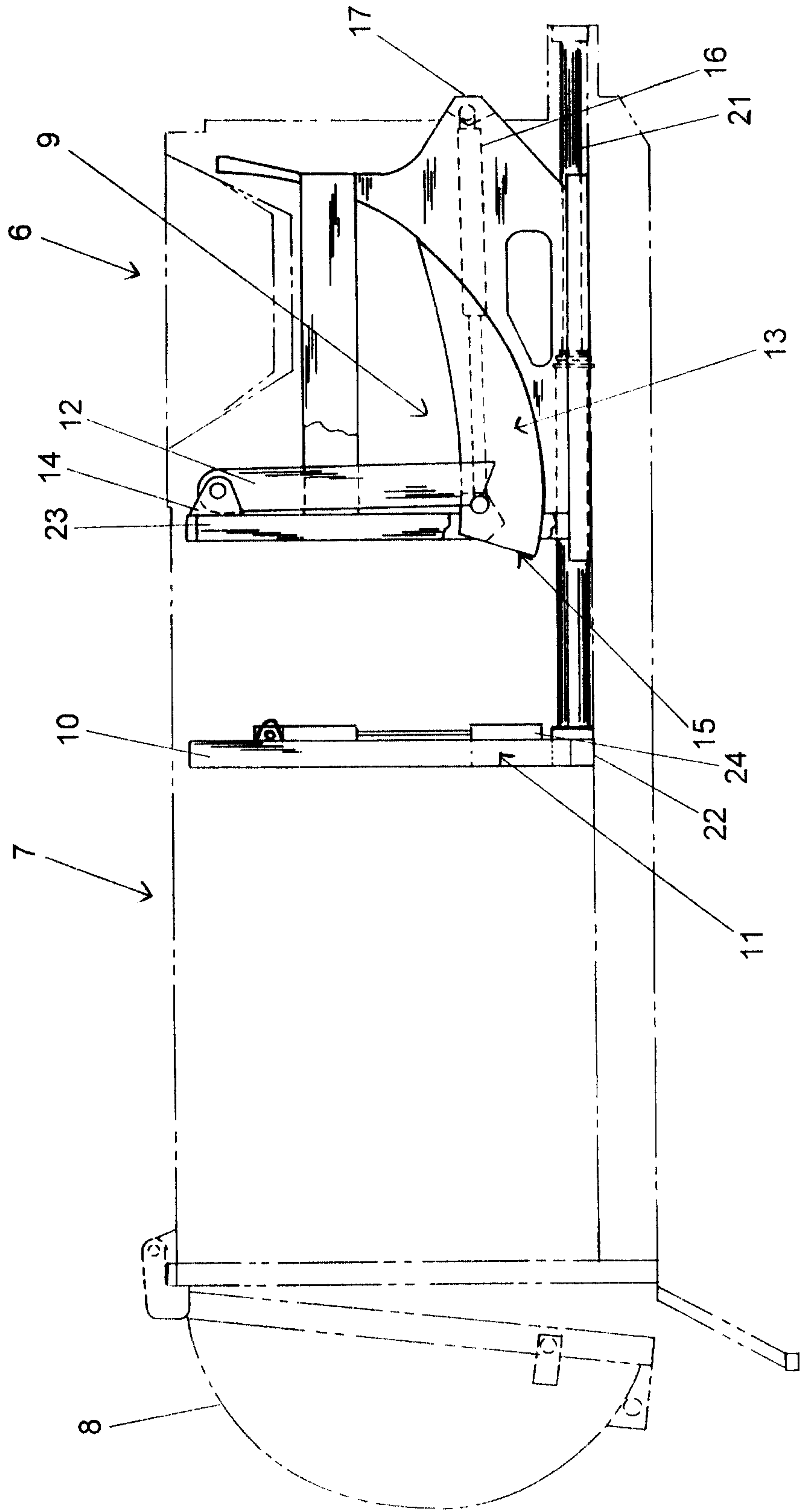

FIG. 7



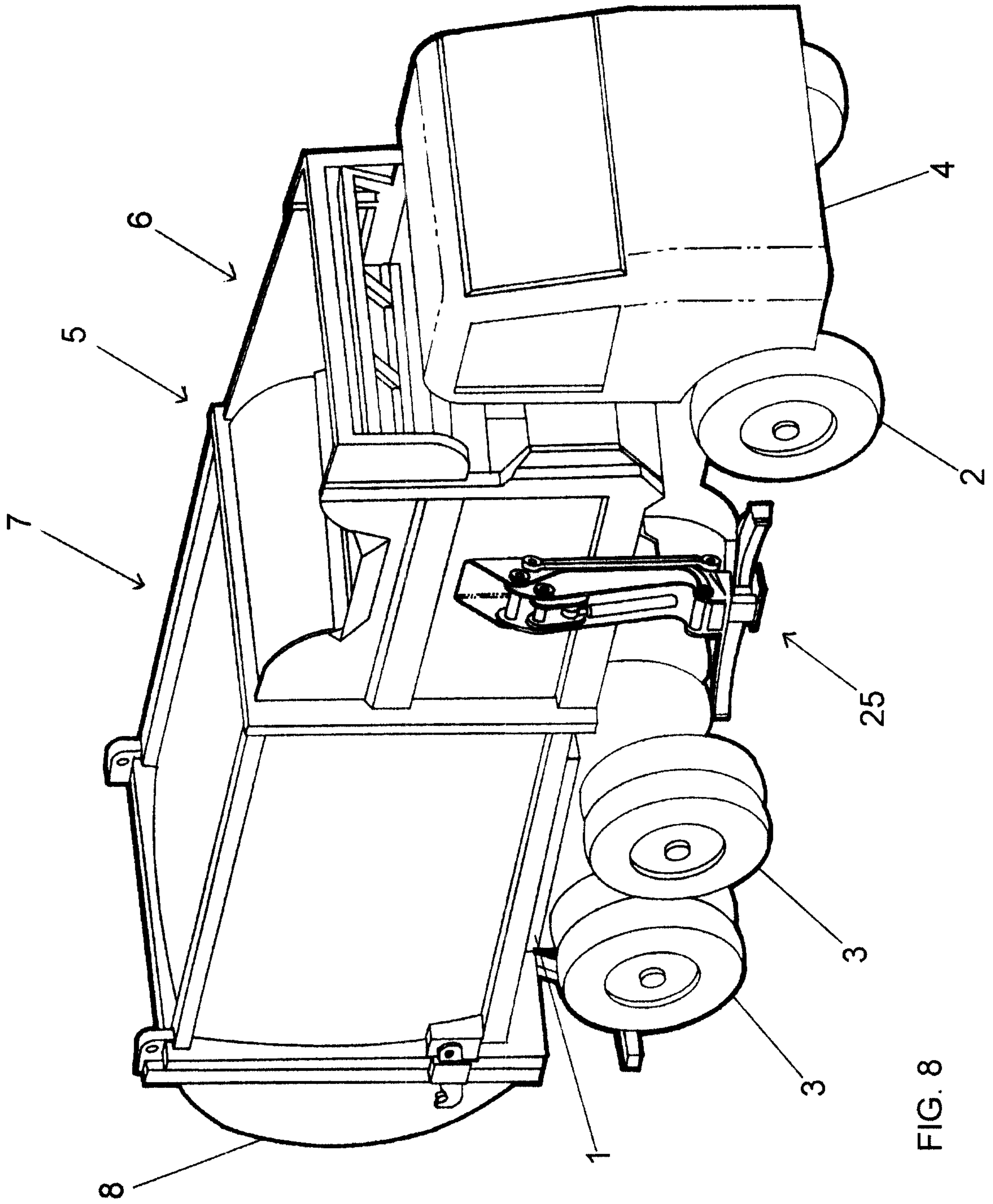

FIG. 8

