

(No Model.)

O. R. SAINT.
METALLIC RAILWAY TIE.

No. 551,691.

Patented Dec. 17, 1895.

FIG. 1.

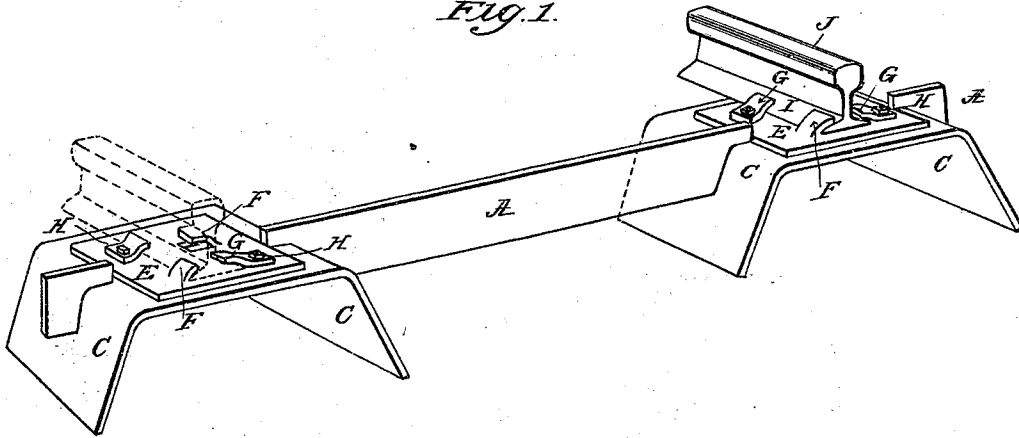

FIG. 2.

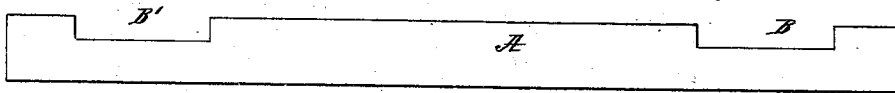

FIG. 3.

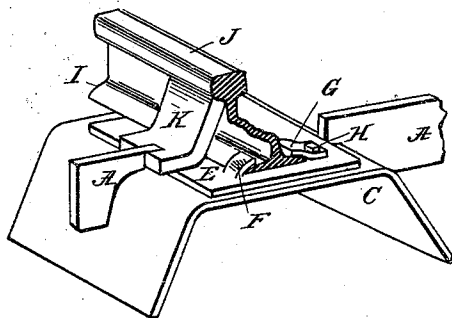

FIG. 4.

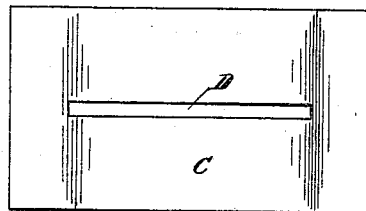

FIG. 5.

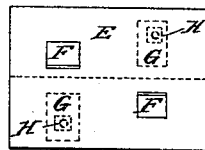
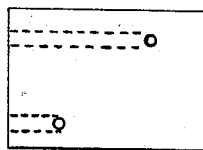

FIG. 6.



WITNESSES:

Edward Rowland.
William J. Farrell

INVENTOR

Otto R. Saint.

BY

Phillips Abbott
ATTORNEY

UNITED STATES PATENT OFFICE.

OTTO R. SAINT, OF NEW YORK, N. Y.

METALLIC RAILWAY-TIE.

SPECIFICATION forming part of Letters Patent No. 551,691, dated December 17, 1895.

Application filed April 27, 1895. Serial No. 547,301. (No model.)

To all whom it may concern:

Be it known that I, OTTO R. SAINT, a citizen of the United States, and a resident of New York city, in the county of New York and State of New York, have invented certain new and useful Improvements in Metallic Railway-Ties, of which the following is a specification.

My invention relates to improvements in metallic railroad-ties; and it consists, generally stated, in a novel construction of the parts whereby simplicity, economy and efficiency are secured in a manner superior to any form of metallic ties heretofore known to me, and whereby, also, the shimming of the track and the retention of the several parts in their proper relative positions are simplified and improved.

Referring to the drawings, Figure 1 illustrates a perspective of the invention, showing all parts in position. Fig. 2 illustrates an elevation of the tie. Fig. 3 illustrates a perspective of one end of a rail and of the tie mechanism somewhat enlarged, showing all the parts in position. Fig. 4 illustrates a plan view of the chair. Fig. 5 illustrates a plan view of the tie-plate. Fig. 6 illustrates a plan view of a shimming-plate.

I prefer to make all the parts of my invention of steel, but iron or iron and steel or metallic alloys may be employed, if preferred.

A is the tie proper. It is provided with recesses B B' located at its upper edge and for ordinary use near its ends, but on crossings, switches and the like they may be located at other places.

C C are the chairs, slotted as at D. They may be of any desired shape, that illustrated being preferred. The slots may run squarely lengthwise of the chairs or at an angle thereto, as may be necessary for the special location in which they are used—that is to say, upon straight tracks the slots are preferably located centrally and running longitudinally of the chairs, but on switches, crossings, &c., they may sometimes advantageously run at an angle relative to the body thereof. The chairs may be of any desired length for any desired number of ties.

E are the tie-plates having lugs F cut from them in approximately opposite corners, as best seen in Fig. 5.

G G are clamping-lugs provided with bolts H, which pass through the tie-plates E and chair C and clamp the upwardly-turned ends of the lugs G firmly down upon the base I of the rail J.

K is a brace for the support of the rail on curves, and if desired upon the straight portion of the track. They may be located on one or both sides of the rail as desired, and it will be noted that the recesses B B' in the tie proper are made of such depth as that, when all the parts are in position, the braces K bear at their upper ends under the heads of the rails and at their other ends are braced against one side or the other of the recesses B B', as the case may be. Consequently they are immovably locked in position.

The method of operation of my invention is as follows: When the track is first laid, the seats are placed in position. The tie A is then placed within the slots D in the seats. The tie-plates E are then placed diagonally or cornerwise relative to the rails, so that they may slip on them easily until they get opposite the seats upon which they are to rest. They are then turned square relative to the rails, with the lugs F F overlapping the base of the rail. The brace K is then put in position underneath the head of the rail, and then all the parts together are dropped into their position in the recess B or B', as the case may be, in the tie, and when so in position it will be observed that the ends of the recesses prevent turning of the tie-plates, and also that the braces K cannot get out of position, being held at their upper ends underneath the head of the rail, and at their lower ends by abutting against one end or the other of the recess in the tie in which they rest. In order to prevent any upward movement of any of these parts relative to the seats, I prefer to employ the bolts H and supplemental lugs G, whereby all of the parts are firmly and permanently clamped in position. When desiring to shim the track, the lugs G and bolts H are removed or loosened and a shimming-plate (see Fig. 6) or equivalent shimming material is introduced beneath the tie-plates E, and between them and the chairs, thus elevating the track at that point the desired distance, but not changing in any other respect the relative arrangements of any of the parts. The shim-

ming-plates may be slotted (see dotted lines) for convenience of introduction, and, if desired, plates or pieces of material similar to the shimming-plates may be permanently used under the tie-plates for the purpose of softening the track or rendering it noiseless.

The shimming-plates may be kept continually in stock of different thicknesses, and they may be of iron, steel, lead, wood, or other suitable material, as preferred. The latter, especially wooden or fibrous shimming-plates, are advantageous under many conditions, since they soften the track, thus reducing wear upon the rolling-stock, and also tend to noiselessness. Under other conditions harder shimming-plates are desirable.

It will be obvious to those who are familiar with this art that modifications may be made in the details of construction and operation of the several parts without departing from the essential features of the invention—as, for example, as above stated, the recesses B B' in the ties may be located in them as necessity requires, and instead of being cut squarely into the same they may be cut diagonally, so as to be adapted to use on switches, crossings, sharp curves, &c.; also the slots in the chairs may be arranged at any preferred angle, and various other modifications may be made.

Having described my invention, I claim—

1. A metallic railway tie, embodying a tie bar recessed on its upper edge, slotted chairs and tie plates adapted to fit the recesses in the tie bars, for the purposes set forth.

2. A metallic railway tie embodying a tie bar recessed on its upper edge, slotted chairs, tie plates adapted to fit the recesses in the tie bars and a brace adapted to fit under the head of the rail at one end and to embrace one end of the recess in the tie bar at the other end, for the purposes set forth.

3. A metallic railway tie, embodying a tie bar recessed on its upper edge, slotted chairs, tie plates adapted to fit the recesses in the tie bars and supplemental fastening lugs and bolts therefor, which pass through said lugs,

the tie plates and the chairs, for the purposes set forth.

4. A metallic railway tie, embodying a tie bar recessed on its upper edge, slotted chairs, tie plates adapted to fit the recesses in the tie bars, supplemental fastening lugs and bolts therefor, which pass through said lugs, the tie plates and the chairs, and a brace, the upper end of which fits under the head of the rail and the other end embraces the shoulder of the recess, for the purposes set forth.

5. The combination in a railway tie of a tie bar recessed on its upper edge, a tie plate provided with lugs which overlap the base of the rail, adapted to fit snugly into the recess in the tie bar, for the purposes set forth.

6. The combination in a railway tie of a tie bar recessed on its upper edge, a tie plate provided with lugs which overlap the base of the rail, adapted to fit snugly into the recess in the tie bar, and a brace adapted to fit under the head of the rail at one end and to embrace the end of the recess above the tie plate at the other end, for the purposes set forth.

7. The combination of a tie bar recessed on its upper edge, slotted chairs, tie plates adapted to fit the recesses in the tie bars and supplemental lugs provided with bolts which pass through said lugs, the tie plate and chair, for the purposes set forth.

8. The combination in a metallic railway tie of a tie bar recessed on its upper edge, slotted chairs, tie plates adapted to fit the recesses in the tie bars, a brace supported upon the upper side of the tie plate and having one end under the head of the rail and the other end notched to embrace the end of the recess in the tie bar, for the purposes set forth.

Signed at New York, in the county of New York and State of New York, this 25th day of April, A. D. 1895.

OTTO R. SAINT.

Witnesses:

PHILLIPS ABBOTT,
WILLIAM J. FARRELL.