



INTERNATIONAL APPLICATION PUBLISHED UNDER THE PATENT COOPERATION TREATY (PCT)

<p>(51) International Patent Classification ⁶ : G01N 33/577, 33/68, C07K 16/18, 16/46, C12P 21/08, C07K 14/78, C12N 5/20</p>	<p>A1</p>	<p>(11) International Publication Number: WO 98/35235</p> <p>(43) International Publication Date: 13 August 1998 (13.08.98)</p>
<p>(21) International Application Number: PCT/GB98/00304</p> <p>(22) International Filing Date: 30 January 1998 (30.01.98)</p> <p>(30) Priority Data: 9702252.9 6 February 1997 (06.02.97) GB</p> <p>(71) Applicant (for all designated States except US): UNIVERSITY OF SHEFFIELD [GB/GB]; Western Bank, Firth Court, Sheffield S10 2TN (GB).</p> <p>(72) Inventors; and (75) Inventors/Applicants (for US only): HOLLANDER, Anthony, Peter [GB/GB]; 5 Greystone Drive, Greystones, Sheffield, South Yorkshire S11 7JQ (GB). CROUCHER, Lisa, Jane [GB/GB]; 34 Westbourne Road, Broomhill, Sheffield, South Yorkshire S10 2QQ (GB).</p> <p>(74) Agents: PRICE, Vincent, Andrew et al.; Fry Heath & Spence, The Old College, 53 High Street, Horley, Surrey RH6 7BN (GB).</p>	<p>(81) Designated States: AL, AM, AT, AU, AZ, BA, BB, BG, BR, BY, CA, CH, CN, CU, CZ, DE, DK, EE, ES, FI, GB, GE, GH, GM, GW, HU, ID, IL, IS, JP, KE, KG, KP, KR, KZ, LC, LK, LR, LS, LT, LU, LV, MD, MG, MK, MN, MW, MX, NO, NZ, PL, PT, RO, RU, SD, SE, SG, SI, SK, SL, TJ, TM, TR, TT, UA, UG, US, UZ, VN, YU, ZW, ARIPO patent (GH, GM, KE, LS, MW, SD, SZ, UG, ZW), Eurasian patent (AM, AZ, BY, KG, KZ, MD, RU, TJ, TM), European patent (AT, BE, CH, DE, DK, ES, FI, FR, GB, GR, IE, IT, LU, MC, NL, PT, SE), OAPI patent (BF, BJ, CF, CG, CI, CM, GA, GN, ML, MR, NE, SN, TD, TG).</p> <p>Published <i>With international search report. Before the expiration of the time limit for amending the claims and to be republished in the event of the receipt of amendments.</i></p>	
<p>(54) Title: ASSAY FOR COLLAGEN TYPE II FRAGMENTS</p>		
<p>(57) Abstract</p> <p>Provided are methods, kits and reagents for assaying for collagen fragments, and to therapeutic, prognostic and diagnostic methods based thereon.</p>		

FOR THE PURPOSES OF INFORMATION ONLY

Codes used to identify States party to the PCT on the front pages of pamphlets publishing international applications under the PCT.

AL	Albania	ES	Spain	LS	Lesotho	SI	Slovenia
AM	Armenia	FI	Finland	LT	Lithuania	SK	Slovakia
AT	Austria	FR	France	LU	Luxembourg	SN	Senegal
AU	Australia	GA	Gabon	LV	Latvia	SZ	Swaziland
AZ	Azerbaijan	GB	United Kingdom	MC	Monaco	TD	Chad
BA	Bosnia and Herzegovina	GE	Georgia	MD	Republic of Moldova	TG	Togo
BB	Barbados	GH	Ghana	MG	Madagascar	TJ	Tajikistan
BE	Belgium	GN	Guinea	MK	The former Yugoslav Republic of Macedonia	TM	Turkmenistan
BF	Burkina Faso	GR	Greece			TR	Turkey
BG	Bulgaria	HU	Hungary	ML	Mali	TT	Trinidad and Tobago
BJ	Benin	IE	Ireland	MN	Mongolia	UA	Ukraine
BR	Brazil	IL	Israel	MR	Mauritania	UG	Uganda
BY	Belarus	IS	Iceland	MW	Malawi	US	United States of America
CA	Canada	IT	Italy	MX	Mexico	UZ	Uzbekistan
CF	Central African Republic	JP	Japan	NE	Niger	VN	Viet Nam
CG	Congo	KE	Kenya	NL	Netherlands	YU	Yugoslavia
CH	Switzerland	KG	Kyrgyzstan	NO	Norway	ZW	Zimbabwe
CI	Côte d'Ivoire	KP	Democratic People's Republic of Korea	NZ	New Zealand		
CM	Cameroon		Republic of Korea	PL	Poland		
CN	China	KR	Republic of Korea	PT	Portugal		
CU	Cuba	KZ	Kazakistan	RO	Romania		
CZ	Czech Republic	LC	Saint Lucia	RU	Russian Federation		
DE	Germany	LI	Liechtenstein	SD	Sudan		
DK	Denmark	LK	Sri Lanka	SE	Sweden		
EE	Estonia	LR	Liberia	SG	Singapore		

ASSAY FOR COLLAGEN TYPE II FRAGMENTS

FIELD OF THE INVENTION

5 The present invention relates to methods, kits and reagents for assaying for collagen fragments, and to therapeutic, prognostic and diagnostic methods based thereon. In particular, the invention relates to type II collagen fragment immunoassays (e.g. Sandwich ELISA), kits and reagents.

10 INTRODUCTION

Type II collagen is the major collagen of hyaline cartilage, accounting for 15-20% of the wet weight of the tissue and 90% of all collagens in cartilage (1). In the extracellular matrix, type II collagen molecules become cross-linked with collagen types IX and XI to
15 form heterotypic fibrils, which endow articular cartilage with the tensile strength necessary to withstand the loading forces resulting from day-to-day use of synovial joints (2).

There are a number of important structural features of the collagen molecule (23), and
20 these are shown in a schematic diagram of a collagen molecule (Figure 1). The primary structure of the human type II collagen $\alpha 1$ chain is shown in Figure 2, and all amino acid residue numbers cited herein refer to the amino acid sequence shown in this Figure.

25 Type II collagen is synthesized with a pro-peptide at both termini of the molecule (residues 1-181 and 1242-1487). These are cleaved off as soon as the collagen is released into the extracellular matrix. The mature molecule has a short telopeptide (non-helical peptide) at both termini (residues 182-200 and 1215-1241) and a triple
30 helix about 1000 residues long (residues 201-1214). Inter- and intra-molecular cross-links are located at 4 sites - one in each telopeptide (residues 190 and 1231) and one near each end of the helical region (residues 308 and 1130). Thus, each end of the molecule contains two stable cross-links.

Cartilage degradation is a major feature of arthritic diseases such as osteoarthritis

(OA) and rheumatoid arthritis (RA). There is currently much interest in monitoring the progress of cartilage loss in such diseases, which provides information useful in disease management (including prognosis, diagnosis and treatment). To this end, cartilage degradation is presently detected and monitored by X-Rays (which can detect joint space narrowing) or by biopsy (where cartilage removed from arthritic or normal joints at arthroplasty is analysed for the presence of biochemical markers of cartilage breakdown). However, both X-Ray and biopsy procedures are inconvenient, expensive and potentially harmful to the patient. Accordingly, there is much interest in alternative methods of monitoring the progress of cartilage breakdown in various arthritic diseases.

Among the known biochemical markers of cartilage breakdown are those arising from a loss of aggrecan (a large, aggregating proteoglycan which contributes to the structural integrity of cartilage) (3-7). Other potential markers are those arising from the degradation of type II collagen, since it is clear that this molecule is damaged in arthritic joints and collagen degradation is generally considered to be an irreversible process (8-11).

There is now good evidence that collagen degradation in cartilage is mediated by a class of enzymes called matrix metalloproteinases (MMPs). In particular, the collagenases (MMP-1 and MMP-13) are thought to be responsible for cleavage of the triple helix of type II collagen, resulting in denaturation of the molecule and its subsequent removal from the cartilage matrix by gelatinases (12-14). In the synovial joint, fragments of extracellular matrix proteins are released from degrading cartilage into the synovial fluid (SF), which lubricates the surface of the tissue.

These fragments can therefore be found at high concentrations in SF from arthritic patients (15-19). They pass from the SF, through the lymphatic system to the systemic circulation. Although levels of cartilage matrix protein fragments in serum are usually lower than in the SF, it is still possible to detect changes in levels of particular marker proteins in the serum in OA and RA.

Although there are a number of assays available to measure aggrecan degradation products (17, 20-22), there are presently no suitable assays for type II collagen

fragments in the systemic circulation (e.g. in serum or urine).

There are two major problems associated with measuring systemic type II collagen fragments. Firstly, turnover of type II collagen in articular cartilage is normally very slow, and so the absolute levels of type II collagen fragments in serum or urine are very low and therefore difficult to detect and measure accurately. Although there is an increase in the rate of turnover of type II collagen in OA cartilage, it is not a large enough change to make detection significantly easier. Therefore a highly sensitive assay is required. The second problem is that circulating type II collagen fragments are small, due to extensive cleavage by gelatinolytic enzymes. This means that polyclonal antibodies to multiple epitopes in denatured collagen cannot be used to set up a "Sandwich" ELISA, because this assay format requires that two different epitopes be present on a single collagen fragment which acts as analyte (see Figure 3B).

It has therefore been proposed to detect single collagen epitopes by use of inhibition ELISA (see Figure 3A). To this end, an assay has been developed which detects a type II collagen epitope that is exposed when the molecule is denatured but which is hidden by conformational restraint in the native collagen (10). Here, the monoclonal antibody Pa-3/4 (also known as Col2-3/4m) was raised to peptide CB11B and shown to recognise denatured type II collagen, but not other fibrillar collagens. An inhibition ELISA based on this antibody was reported to detect type II collagen fragments bearing the epitope, and to demonstrate increased levels of denatured type II collagen extracted from OA articular cartilage compared to non-arthritic cartilage.

However, it has now been found that this assay is not in fact useful in the detection of type II collagen fragments in sera and SFs. The large values measured for collagen fragments in serum were a result of interference in the inhibition ELISA by collagen binding proteins (such as fibronectin), resulting in false positive data. Indeed, it has now been found that once interfering proteins are removed by digestion with proteinase K (an enzyme that does not damage the CB11B epitope), no serum type II collagen can be detected by the assay. A further contributing factor to this negative result is likely to be that the standard curve for the assay is steep and lacks sensitivity: the lower detection limit is in the region of 50µg/ml type II collagen.

Thus, the inhibition ELISA presents two problems with respect to the detection of type II collagen fragments in serum. Firstly, it lacks the sensitivity needed for the detection of fragments that are probably present only at low levels in the systemic circulation. Secondly, it is subject to interference by any protein that can bind to the heat
5 denatured collagen which is used to coat the wells of the ELISA plate.

There is therefore a need for an alternative immunoassay for collagen fragments which avoids the above mentioned problems.

10 DESCRIPTION OF THE INVENTION

It has now been discovered that the type II collagen molecule is comprised of regions which differ dramatically in their susceptibility to hydrolysis. In particular, it has now been discovered that the amino-acids falling within the amino terminus cross-link
15 region of the triple helix (residues 201-308) of the type II collagen α 1-chain are much less susceptible to hydrolysis by MMPs than the rest of the α 1-chain. In contrast, the cross-linked region at the carboxy-terminus of the triple helix (residues 1130-1214) is less stable, reflected in the lower melting temperature than the amino-terminal end of the molecule (so making it more susceptible to hydrolysis).

20 Moreover, it has now surprisingly been found that collagen fragments released from degraded type II cartilage *in vivo* (hereinafter designated C-II_{free}) comprise fragments which are sufficiently large to bear two or more different epitopes, and that the half life of these fragments *in vivo* is long enough to permit the build up of concentrations high
25 enough to make detection and/or accurate measurement by immunoassay in various body fluids (including serum, urine or synovial fluid) possible.

Moreover, it has also been found that these epitopes can independently and simultaneously bind their cognate antibodies. Thus, it is now possible to make two
30 different antibodies to different epitopes on the same C-II_{free} fragment, so permitting, for the first time, Sandwich ELISA of free (e.g. serum) type II collagen fragments.

Sandwich assays are inherently more sensitive than inhibition type assays, and are not be subject to interference from collagen-binding proteins.

Thus, according to the present invention there is provided a kit (e.g. an immunoassay kit) comprising a first antibody (e.g. a monoclonal antibody, polyclonal antibody or fragment or derivative thereof) which binds to a first epitope and a second antibody
5 (e.g. a monoclonal antibody, polyclonal antibody or fragment or derivative thereof) which binds to a second epitope, wherein the first and second epitopes are coupled epitopes present on a collagen fragment (for example, a type I or type II collagen fragment) released from degraded cartilage *in vivo*. Preferably, the first and second epitopes are coupled epitopes present on C-II_{free}.

10

As used herein, the term C-II_{free} embraces any of those type II collagen fragments which are released from degraded cartilage, for example by release *in vivo* as a result of cartilage degradation associated with various diseases or disorders (such as OA and RA).

15

Thus, C-II_{free} include collagen fragments which have entered the systemic circulation (hereinafter referred to as C-II_{systemic}). Such fragments include collagen fragments which may be found in the serum, urine and synovial fluid (the latter abbreviated herein to SF).

20

As used herein, the term "coupled epitopes" refers to antigenic epitopes which are each present on a single type II collagen fragment or analyte moiety. Coupled epitopes may therefore comprise one or more conformational epitopes, either on a single type II collagen fragment or on a single analyte moiety which comprises a type
25 II collagen fragment complex (e.g. two or more associated collagen fragments which together comprise a single analyte moiety).

In preferred embodiments, each coupled epitope is a sequential epitope, so that all coupled epitopes are present on a single type II collagen peptide fragment.

30 Particularly preferred are coupled epitopes comprising or located within an amino acid sequence or a fragment of the N-terminal region of the $\alpha 1$ type II collagen chain, for example coupled epitopes comprising or located within an amino acid sequence or a fragment of the N-terminal cross-linked region of the triple helix thereof (see Figure 1).

In a particularly preferred embodiment, the first epitope is located within residues 243-263 of the sequence shown in Figure 2, and the second epitope is located within residues 216-236 of the sequence shown in Figure 3.

5

The coupled epitopes may simultaneously bind cognate antibodies, and may advantageously be disposed such that an antibody bound at the first epitope does not sterically hinder (or interfere with) antibody binding at the second epitope. The coupled epitopes of the invention may therefore be physically "linked", so that that sequestration or partitioning of one of the epitopes attendant on binding to its cognate antibody effectively also sequesters or partitions the other (linked) epitope (while leaving it available for binding to a second cognate antibody).

10

The coupled epitopes are preferably separated by at least 2 amino acids, e.g. by 3,4, 5, 6, 7, 8, 9, 10, 11, 12,13, 14, 15, 16, 17, 18, 19 or 20 amino acids. Preferably, they are separated from each other by at least 3 amino acids (e.g. about 6 amino acids) to prevent steric hindrance of simultaneous antibody binding.

15

In general, the coupled epitopes are sufficiently separated to permit independent (non-blocking) binding to cognate antibodies, but sufficiently close together to substantially eliminate the possibility of a proteolytic cleavage event uncoupling or separating the epitopes. Thus, the coupled epitopes are preferably separated by a short amino acid sequence which is not subject to substantial proteolysis *in vivo*, for example in a portion of the type II collagen molecule which is relatively stable or which is relatively resistant to proteolysis. Particularly preferred is the N terminal portion of the $\alpha 1$ type II collagen peptide (e.g. the N terminal cross-linked region of the triple helix thereof).

20

25

The immunoassay kit of the invention may be used in therapy, diagnosis, prognosis or candidate drug screening.

30

Preferably, the immunoassay kit of the invention is for use in Sandwich immunoassay (e.g. for use in Sandwich ELISA). In such embodiments, the first antibody may be immobilized on a solid support, and/or the second antibody may be

labelled.

In such embodiments, the immobilized primary antibody (or capture antibody) is preferably monoclonal (e.g. a mouse monoclonal antibody), while the secondary antibody is preferably polyclonal (e.g. a rabbit polyclonal antibody) and derived from a different species to the capture antibody. This permits the use of species-specific labelled anti-Ig antibodies to detect bound (unlabelled) secondary antibody, so obviating the need for labelled collagen-specific antibodies. In such embodiments, the anti-Ig antibody is preferably labelled with alkaline phosphatase or peroxidase.

10

Alternatively, the secondary antibody may be labelled. Preferred labels include radiolabels and biotin. Where biotin is used, the secondary antibody may be detected by contacting the secondary antibody with enzyme-labelled avidin.

15 Where the kit comprises an enzyme-labelled reactant, the kit preferably further comprises a substrate to react with the enzyme label.

The kit may further comprise standard heat denatured type II collagen or a standard synthetic peptide carrying C-II_{free} coupled epitopes (e.g. AH8 and AH12). Such synthetic peptides may comprise a protease-resistant spacer region between the coupled epitopes. Such synthetic peptides may be synthesised, for example, by solid phase peptide synthesis or by expression of synthetic gene(s) in a recombinant host cell.

25 As used herein, the terms AH8, AH9 and AH12 are used to refer to particular peptide epitopes or peptides *per se* (as sense dictates and as described in more detail *infra*). The terms AH8L1, AH9L2 and AH12L3 refer to the rabbit antisera to the AH8, AH9 and AH12 peptides, respectively. The term AH8MAb refers to a monoclonal antibody to peptide AH8. The terms anti-AH8, anti-AH9 and anti-AH12 refer to antibodies raised against (or (specifically) reactive with) the peptides AH8, AH9 and AH12, respectively.

30

In particularly preferred embodiments, the first antibody is AH8MAb or AH8L1 and the second antibody is AH12L3. Alternatively, the first antibody may be AH12L3 and

the second antibody AH8MAb or AH8L1.

The first antibody may also be an antibody which competitively inhibits binding of AH8MAb or AH8L1 to cognate epitope, and the second antibody may be an antibody
5 which competitively inhibits binding of AH12L3 to cognate epitope. Alternatively, the first antibody may be an antibody which competitively inhibits binding of AH12L3 to cognate epitope and the second antibody may be an antibody which competitively inhibits binding of AH8MAb or AH8L1 to cognate epitope.

10 In other embodiments, the first antibody may be an antibody having the same (or essentially the same) epitope specificity as antibody AH8MAb or AH8L1, while the second antibody may be an antibody having the same (or essentially the same) epitope specificity as antibody AH12L3. Alternatively, the first antibody may be an antibody having the same (or essentially the same) epitope specificity as antibody
15 AH12L3, while the second antibody may be an antibody having the same (or essentially the same) epitope specificity as antibody AH8MAb or AH8L1.

Binding agents other than antibodies having functionally similar properties to the antibodies of the invention may also be used according to the invention. Thus, the
20 first and/or second antibody may be a binding agent derived from, comprising or consisting essentially of the variable region of an antibody having the required specificity (for example antibody AH8MAb, AH8L1 or AH12L3). Binding agents for use in the invention therefore include various antibody fragments, such as Fab, Fab' or F(ab')₂ fragments, or synthetic proteins and peptides modelled on sequences
25 variable regions having the desired specificity.

In another aspect, the invention relates to an antibody (e.g. a monoclonal antibody, polyclonal antibody, or fragment or derivative thereof) per se which binds to a coupled epitope of C-II_{free}. The antibodies of the invention may be monoclonal or
30 polyclonal, and are preferably labelled. Preferred labels include biotin and radioactive labels. The antibodies of the invention may also be immobilized (e.g. on a solid support, such as the well of a microtitre plate or surface of a probe or dipstick).

Also contemplated by the invention are bifunctional heteroantibodies comprising a

first binding moiety which binds to a first epitope and a second binding moiety which binds to a second epitope, wherein the first and second epitopes are C-II_{free} coupled epitopes. Such heteroantibodies find application in various immunoprecipitation assays, since they form readily detectable high molecular weight complexes in the presence of coupled C-II_{free} epitopes.

Also contemplated by the invention are methods (e.g. Sandwich ELISA methods) for assaying for C-II_{free} in a biological sample (e.g. *in vitro* or *ex vivo*) comprising contacting the sample with a first antibody which binds to a first epitope and with a second antibody which binds to a second epitope, wherein the first and second epitopes are C-II_{free} coupled epitopes.

The methods of the invention find application in various *in vitro* or *ex vivo* methods of therapy, diagnosis or prognosis comprising the step of assaying a biological sample for C-II_{free}.

The invention also contemplates a process for measuring the therapeutic activity of an agent comprising the steps of: (a) providing a sample derived from a subject treated with the agent; and (b) assaying the sample for C-II_{free} using the kit, antibody/binding agent or the method of the invention, wherein the amount of C-II_{free} in the sample assayed in step (b) is used as an index of therapeutic activity.

In another aspect, the invention provides a process for producing a therapeutic agent comprising the step of screening a library of candidate therapeutic agents for therapeutic activity using the therapeutic activity measuring process of the invention described above.

In yet another aspect, the invention contemplates a process for producing a therapeutic agent comprising the steps of: (a) selecting a chemical formula on the basis of one or more structural features of a therapeutic agent produced by the process for producing a therapeutic agent of the invention; and then (b) producing (e.g. by synthesis or isolation) a therapeutic agent having the chemical formula selected in step (a). Also covered are therapeutics obtainable by (or obtained by) this process. These preferably include anti-arthritis drugs and MMP inhibitors.

In yet another aspect, the invention contemplates a cell or cell line which expresses the antibody or binding agent of the invention. The cell or cell line may be prokaryotic or eukaryotic (e.g. mammalian). Preferred are hybridomas expressing
5 monoclonal antibodies according to the invention.

In a still further aspect of the invention there is provided a process for producing an antibody which binds to a coupled epitope of C-II_{free} comprising the steps of: (a) degrading type II collagen *in vitro* to produce a plurality of fragments; (b)
10 fractionating the fragments on the basis of size; (c) identifying relatively large fragments; (d) screening the relatively large fragments for the presence of multiple epitopes; (e) selecting a fragment which bears two or more epitopes; and (f) raising antibodies against the fragment selected in step (e).

15 Also covered by the invention are antibodies which bind to a coupled epitope of C-II_{free} obtainable (or obtained by) the process described above.

The invention also covers isolated type II collagen fragments bearing two or more epitopes for use in step (f) of the processes of the invention, as well as processes for
20 producing an antibody or C-II_{free} binding agent comprising raising antibodies against the isolated fragments of the invention.

APPLICATIONS

25 The invention finds application in various assays, including diagnostic, prognostic and drug screening assays. The invention may also be used as part of a therapeutic regimen, as described below. Thus, the invention may be useful in various forms of therapy, prognosis and diagnosis.

30 For example, in diagnosis the sandwich ELISAs of the invention are sensitive enough to detect type II collagen fragments in urine, serum or SFs from patients. The samples can be easily obtained without risk to the patient, and the assay is simple and inexpensive. Thus, routine screening of a population for arthritic or other diseases in which cartilage breakdown occurs is possible using the methods and reagents of the

invention.

The invention can also be used to determine the degree of on-going cartilage collagen degradation in patients with different types of OA or RA . The assays may therefore
5 also find utility as the basis of prognostic tests, for example to predict which patients will go on to develop severe cartilage lesions.

In therapy, the invention provides a means of determining the *in vivo* efficacy of anti-arthritic drugs, such as MMP inhibitors. A number of such drugs are about to be tested
10 in clinical trials (3, 26), but prior to the invention there has been no way of following type II collagen degradation using a urine, serum or SF marker, to determine if the patients are protected by treatment. The invention may therefore find application as an adjunct to various forms of therapy or as a means for determining the optimum dosage and/or frequency of administration of therapeutic drugs.

15 Further uses of the assays of the invention include the diagnosis of growth disorders and the testing of the efficacy or monitoring the progress of growth hormone treatment. For example, long bone growth depends on the process of endochondral ossification, in which growth plate cartilage is degraded and replaced with bone (1). Serum levels
20 of type II collagen fragments will therefore be higher in normal growing children than in adults, reflecting this process. However in children with growth disorders the serum levels of these fragments are likely to be lower than is normal for children of any given age. Thus, the invention may be used to diagnose such disorders, as an adjunct to drug treatment to establish dose-response relationships and also to monitor the
25 progress of the disorder and its treatment.

The invention will now be described with reference to several examples, which are for illustrative purposes only and are not limiting in any way.

30 The examples refer to several Figures, in which:

Figure 1: shows schematically the different molecular zones or domains in the type II collagen α -chain and the location of the epitopes used to generate antibodies.

1: epitope AH12

- 2: epitope AH8
 3: epitope CB11B
 4: triple helical region
 5: collagenase cleavage site
 5 6: helical cross-link
 7: epitope AH9
 8: carboxy-terminal pro-peptide
 9: carboxy-terminal telo-peptide
 10: telo-peptide cross-link
 10 11: carboxy-terminal cross-linked region
 12: helical cross-link
 13: amino-terminal cross-linked region of the triple helix
 14: amino-terminal telo-peptide
 15: amino-terminal pro-peptide
 15 16: telo-peptide cross-link

Figure 2: shows the primary structure (amino acid sequence) of the human type II collagen α -chain.

- 20 Figure 3: shows schematically the Inhibition ELISA assay format and the Sandwich ELISA assay format.

Panel A: Inhibition ELISA

- 1: type II collagen fragments in solution phase bind to primary antibody, inhibiting it from binding to the solid phase collagen.
 25 2: primary anti-collagen antibody binds to solid phase denatured collagen.
 3: heat denatured type II collagen coated onto solid phase.
 4: enzyme labeled second step antibody binds to primary antibody.

30 Panel B: Sandwich ELISA

- 1: enzyme-labeled avidin binds to biotin
 2: type II collagen fragments in solution phase bind to the primary antibody *via* the first epitope on the collagen fragments.
 3: primary anti-type II collagen antibody coated onto solid

phase.

4: biotinylated secondary anti-type II collagen antibody binds to second epitope on collagen fragments.

- 5 Figure 4: shows the characterization of antiserum AH8L1. Antiserum AH8L1 was tested in ELISA assays against peptide AH8 (Panel A) and HDC (Panel B). The results are shown for specific antiserum (circles) compared to the pre-immune serum (diamonds) for both antigens.
- 10 Figure 5: shows the characterization of antiserum AH9L2. Antiserum AH9L2 was tested in ELISA assays against peptide AH9 (Panel A) and HDC (Panel B). The results are shown for specific antiserum (circles) compared to the pre-immune serum (diamonds) for both antigens.
- 15 Figure 6: shows the characterization of antiserum AH12L3. Antiserum AH12L3 was tested in ELISA assays against peptide AH12 (Panel A) and HDC (Panel B). The results are shown for specific antiserum (circles) compared to the pre-immune serum (diamonds) for both antigens.
- 20 Figure 7: shows the cross-reactivity of anti-peptide anti-sera with different collagens. A) Coomassie stained gel; B) rabbit anti-peptide AH8L1 antiserum; C) rabbit anti-peptide AH9L2 antiserum; D) rabbit anti-peptide AH12L3 antiserum. In all 3 panels, lane 1 is human type 1 collagen, lane 2 is bovine type I collagen, lane 3 is human type II collagen, lane 4 is bovine type II collagen, lane 5 is human type III collagen, lane 6 is bovine type III collagen and lane 7 is human type IV collagen.
- 25
- Figure 8: shows Western immunoblots of bovine chondrocyte lysates. The lysates were prepared with (lane 1) or without (lane 2) the addition of bovine type II collagen. Panel A is an amido black stain of total protein in the lysates after transfer to nitrocellulose. Panels B, C and D are Western immunoblots using antibodies AH8L1, AH9L2 and AH12L3 respectively. The migration position of the type II collagen α -chain is shown.
- 30
- Figure 9: shows Western immunoblots of week 3 medium from bovine nasal

cartilage cultures. Medium from IL-1-stimulated cartilage cultures was separated by SDS-PAGE on 15% gels and electroblotted to a nitrocellulose membrane. Panel A shows an amido black stain of total protein in the lysates after transfer to nitrocellulose. Panels B, C, D and E show Western immunoblots with antibodies Pa-3/4, AH8L1, AH9L2 and AH12L3, respectively. The migration position of the two most clearly defined collagen fragments are indicated, as well as the molecular weight standards.

10 Figure 10: shows the location of the amino-terminus of fragment TII-F1 within the type II collagen triple helix.

Figure 11: shows dual binding of AH8L1 and AH12L3 to HDC. Purified, biotinylated antibody AH8L1 was bound to HDC on its own (circles in both panels) and following preincubation of the HDC with antiserum AH12L3 at a 1:100 dilution (diamonds in Panel A) or with purified antibody AH12L3 at a 1:64 dilution (diamonds in Panel B). Binding of AH8L1 was detected using the avidin-peroxidase conjugate method described infra.

20 Figure 12: shows a comparison of type II collagen assays. HDC was assayed at a range of standard concentrations either using the Sandwich ELISA of the invention (Panel A) or the known CB11B inhibition ELISA (Panel B).

25 Figure 13: shows immunohistochemical staining of human OA femoral head cartilage from a human subject. Staining was with mouse monoclonal antibody Col2-3/4m (A and D), rabbit polyclonal antibody AH12L3 (B and E) and rabbit polyclonal antibody AH9L2 (C and F). Negative controls (non-immune IgG) are shown separately for mouse (G) and rabbit (H).

30 Figure 14: shows immunohistochemical staining of human normal femoral head cartilage from a human subject. Staining was with mouse monoclonal antibody Col2-3/4m (A), rabbit polyclonal antibody AH12L3 (B) and rabbit polyclonal antibody AH9L2 (C). Negative controls (non-immune IgG) are shown separately for mouse (D) and rabbit (E).

Figure 15: shows dual binding of antibodies AH8MAb and AH12 to HDC. Purified

antibody AH12 was bound to HDC either on its own (squares) or following preincubation of the HDC with AH8MAb (circles) and was detected using an alkaline phosphatase labeled goat anti-rabbit Ig second antibody. The binding of monoclonal AH8MAb on its own, detected by an alkaline phosphatase labeled goat anti-mouse Ig second antibody, is shown for comparison (triangles).

5
10
Figure 16: shows the AH8MAb/AH12L3 sandwich ELISA standard curve. Results are shown as the mean +/- SEM for 11 separate experiments, using type II collagen purified from bovine nasal septum cartilage.

15
Figure 17: shows specific detection of denatured type II collagen by the AH8MAb/AH12L3 sandwich ELISA. Native bovine type II collagen was prepared as described in Example 5 and then a portion was denatured. The samples were then assayed at a series of dilutions.

20
Figure 18: shows type II collagen fragments in normal human serum. Serum was collected from male (n=3) and female (n=5) volunteers (age range 23-33 years) and assayed at various dilutions using the AH8MAb/AH12L3 sandwich ELISA. Each panel shows results for one individual.

25
Figure 19: shows the estimation of type II collagen fragment levels in normal human serum. Serum was collected from male (n=3) and female (n=5) volunteers (age range 23-33 years) and assayed using the AH8MAb/AH12L3 sandwich ELISA. Values of collagen fragment concentration were estimated using a heat denatured bovine type II collagen standard curve.

Figure 20: shows the standard synthetic peptide for use in the AH8MAb/AH12L3 sandwich ELISA.

30
EXAMPLE 1 - Identification of Immunogenic Epitopes, Peptide Synthesis and Coupling to Carrier Protein.

Amino acid sequences from the amino- and carboxy-terminal cross-linked regions of the $\alpha 1(\text{II})$ chain were subjected to hydrophobicity analysis and suitable immunogenic

peptides were selected using the criteria previously described (10).

Peptides AH8, AH9 and AH12 were each synthesized with an amino-terminal cysteine for coupling to carrier protein and a carboxy terminal tyrosine for possible iodination.

5 AH8 and AH12 are located in the amino-terminal cross-linked region of the triple helix and AH9 is in the carboxy-terminal cross-linked region, as shown in Figure 1. The peptides were synthesized by Dr. Arthur Moir in the Krebs Institute, University of Sheffield and their sequences are:

10 AH8

C-G-P-P(OH)-G-P-P(OH)-G-K-P(OH)-G-D-D-G-E-A-G-K-P(OH)-G-K-A-Y

AH9

15

C-G-P-P(OH)-G-P-R-G-R-S-G-E-T-G-P-A-G-P-P(OH)-G-N-P(OH)-Y

AH12

20 C-G-A-P(OH)-G-P-Q-G-F-Q-G-N-P(OH)-G-E-P(OH)-G-E-P(OH)-G-V-S-Y

Each of these peptides was conjugated to the carrier protein, Keyhole Limpet Haemocyanin (Calbiochem, Nottingham, UK), through its amino-terminal cysteine residue, using the coupling reagent bromoacetic acid-N-hydroxysuccinimide ester (Sigma). The method of conjugation was exactly as previously described for peptide coupling to ovalbumin (10).

25

EXAMPLE 2 - Antibody Production

30 Adult New Zealand white rabbits were each immunised by subcutaneous injection with 500 µg of peptide conjugated to KLH. Each peptide was used to immunise two animals. For the initial immunisation the antigen was emulsified with Complete Freund's Adjuvant (Sigma). Subsequent immunisations were at two-week intervals and Incomplete Freund's Adjuvant (Sigma) was used. Pre-immune and specific test

sera were screened for reactivity with type II collagen, as described below.

EXAMPLE 3 - Antibody Screening ELISAs

- 5 Heat denatured type II collagen (HDC) was prepared by dissolving bovine type II collagen (Sigma) in 0.1M carbonate buffer (0.1M NaHCO₃, 0.1M Na₂CO₃, pH 9.2) and heating at 80°C for twenty minutes. Immulon-2 ELISA plates (Dynatech Labs, Guernsey, UK) were coated with 2µg per well of HDC by passive adsorption for 72 hours at 4°C. The plates were washed three times with PBS containing 0.1% v/v
- 10 Tween-20 (Sigma; PBS-Tween) and then blocked by incubation with 1% w/v bovine serum albumin (BSA, Sigma) in PBS, for thirty minutes at room temperature. The plates were washed once with PBS-Tween and Rabbit antisera were added to wells of the ELISA plates at a range of dilutions.
- 15 After incubation for ninety minutes at 37°C the plates were washed three times with PBS-Tween and then alkaline-phosphate labelled goat anti-rabbit immunoglobulin (Southern Biotech, Alabama, USA) diluted 1:1000 in PBS-Tween-1% BSA was added to each well. The Plates were incubated for ninety minutes at 37°C then washed three times with PBS-Tween and once with distilled water. The alkaline-phosphatase
- 20 substrate, disodium p-nitro-phenyl phosphate was prepared fresh at a concentration of 0.5mg/ml in 9.0mM diethanolamine, 0.25M MgCl₂, pH 9.8, and added to each well for 20-30 minutes at R.T. The absorbance was measured at 405nm on a Dynatech Multiscan plate reader.

25 EXAMPLE 4 - SDS-PAGE and Western Immunoblotting

- SDS-PAGE was performed on 7.5%, 10% or 15% miniprotean gels (Bio-Rad Labs, Hertfordshire, UK), under reducing conditions, essentially as described previously (10). The gels were stained with 0.2% w/v Coomassie Brilliant Blue (Bio-Rad) in 50% v/v
- 30 methanol, 10% v/v acetic acid and destained with 20% v/v methanol, 5% v/v acetic acid. In some cases the electrophoresed samples were transferred to nitrocellulose membranes in a Tris-Glycine buffer containing 10% or 20% v/v methanol and blocked overnight at room temperature with PBS-3% BSA prior to immunoblotting with antibodies Pa-3/4, AH8L1, AH9L2 or AH12L3.

Blocked membranes were incubated for two hours at room temperature with these antibodies, each at an appropriate dilution in PBS-3% BSA. After three washes with PBS-Tween, the membranes were incubated for thirty minutes at room temperature with the alkaline phosphatase-conjugated goat anti-mouse (for Pa-3/4) or anti-rabbit (for AH8, 9 and 12) second antibody, diluted 1:1000 with PBS-3% BSA. The membranes were washed three times with PBS-Tween and once with distilled water. Alkaline phosphatase substrate solution was prepared from a kit (Bio-Rad) employing 5-bromo-4-chloro-3-indoyl phosphate and nitroblue tetrazolium. It was added to membranes and incubated at room temperature until optimal colour had developed. The reaction was stopped by rinsing with distilled water.

EXAMPLE 5 - Bovine Nasal Cartilage Cultures

Freshly dissected cartilage from bovine nasal septum was sectioned into slices of 5cm x 1.5cm x 2mm with a scalpel. The slices were washed once with sterile PBS for twenty minutes. Discs of cartilage (40mg average wet weight) were prepared using a sterile stainless steel punch. The outer parts of the cartilage slices were not used to avoid contamination with other tissues.

20

The nasal and articular cartilage explants were cultured in serum free Dulbecco's modified Eagle's medium (DMEM; Gibco Life Technologies Ltd., Renfrew Road, Paisley, UK), containing glutamine (2mM), penicillin G (2000 U/ml) and streptomycin (0.1 mg/ml) and 4-(2-hydroxyethyl)-1-piperazineethanesulfonic acid (HEPES, 10mM) (all from Gibco) for four weeks in 48-well tissue culture plates (Costar, High Wycombe, UK) at 37°C in a humidified atmosphere of 5% CO₂/95% air. Each well contained two discs in 400µl of medium. The discs were treated with recombinant human IL-1α was a kind gift from Dr. Michael B. Widmer, Immunex Corp., Seattle, USA. At days 7, 14 and 21, medium in each well was replenished, including fresh IL-1α.

30

EXAMPLE 6 - Amino Terminal Sequencing

For amino-terminal sequencing, medium samples were run on gels that had been pre-run with a free-radical scavenger and then subject to buffer exchange for correction of

pH, as described by Dunbar and Wilson (27). The samples were electroblotted to a PVDF membrane (Bio-Rad) and stained with 0.5% w/v Coomassie Brilliant Blue R-250 in 7% v/v acetic acid, 35% v/v methanol for ten minutes and destained in 7% v/v acetic acid 25% methanol until the background was clear. The relevant protein band was
5 excised and analysed using an automated sequencing facility, by Bryan Dunbar, Department of Molecular and cell Biology, University of Aberdeen.

EXAMPLE 7 - Affinity Purification and Biotinylation of Antibodies

10 Antibodies were purified and biotinylated using a blotting membrane as an antigen support, according to the newly described method of Rucklidge et al (28). AH8L1 and AH12L3 antibodies were both affinity purified from immune rabbit sera using PVDF membranes (Bio-Rad) coated with HDC. AH8L1 antibody was biotinylated while still bound to the membrane by incubating with biotin (Biotinamidocaproate N-
15 hydroxysuccinimide ester, Sigma) at 75µg/ml in 0.1M carbonate buffer for thirty minutes, before stripping from the membrane. The purified antibodies were both tested for yield and specificity before use.

EXAMPLE 8 - Sandwich ELISA Assay for Type II Collagen Fragments

20 Capture antibody (affinity purified AH12L3) at a dilution of 1:8 in 0.1M carbonate buffer was allowed to passively bind to an Immulon 2 plate at 37°C for one hour. All wells were then blocked for one hour at 37°C with carbonate buffer containing 0.2% BSA, then washed three times with PBS/Tween. HDC was diluted in PBS, added to
25 appropriate wells and incubated for ninety minutes at 37°C.

After a further three washes in PBS/Tween, detecting antibody (biotinylated AH8L1) was added to all wells at a dilution of 1:8 in PBS/Tween/0.1% BSA and incubated for a further ninety minutes. Plates were washed three times in PBS/0.1% Tween, then
30 incubated with avidin-peroxidase (Sigma) at 20mg/ml in PBS/Tween for thirty minutes at room temperature, followed by a further three washed in PBS/Tween and one in distilled water. Peroxidase substrate (o-phenolenediamine dihydrochloride, Sigma) at a concentration of 0.5mg/ml in 0.05M citric acid with 0.1M Na₂HPO₄ and 10µl H₂O₂ was added to all wells and colour developed for 20-30 minutes before stopping with 10M

H₂SO₄. Absorbences were read at 490nm.

EXAMPLE 9 - Characterisation of Rabbit Antisera To Peptides AH8, 9 and 12

5 Each peptide was used to generate antisera in two rabbits. For all three peptides, both antisera behaved essentially in the same way as each other with respect to titre and specificity.

10 In ELISA assays, antibody AH8L1 specifically reacted with peptide AH8 and with HDC (Figure 4), but it did not react with peptides AH9 or AH12 (data not shown). Antibody AH9L2 specifically reacted with peptide AH9 and with HDC (Figure 5), but it did not react with peptides AH8 or AH12 (data not shown). Antibody AH12L3 specifically reacted with peptide AH12 and with HDC (Figure 6), but it did not react with peptides AH8 or AH9 (data not shown). AH9L2 was clearly less potent than AH8L1 or AH12L3
15 at detecting type II collagen in the ELISA assays (compare Figures 4B, 5B and 6B).

Antibodies AH8L1, AH9L2 and AH12L3 were each tested in western immunoblotting for reactivity with different types of heat denatured collagen. Each of them recognised only type II collagen and not collagen types I, III or IV (Figure 7), however AH9L2 was
20 less effective at detecting the type II collagen by this technique than AH8L1 or AH12L3.

As a further demonstration of specificity, each antibody was tested in a Western immunoblot against the many proteins present in chondrocyte lysates. None of these
25 proteins were detected by any of the antibodies whereas they each detected type II collagen which had been added to the lysates (Figure 8).

EXAMPLE 10 - Detection of Type II Collagen Fragments In Culture Media From Bovine Nasal Cartilage Cultures

30

When bovine nasal cartilage is stimulated with 50ng/ml IL-1 α , there is a sudden release of type II collagen fragments into the medium during the third week of culture which coincides with a large increase in MMP activity in the medium (14). Week 3 medium was taken from such highly degradative cultures and examined by western

immunoblotting to determine if any of the type II collagen fragments were large enough to appear on a 10% SDS-PAGE gel.

5 Using the inhibition ELISA for CB11B, large amounts of this epitope were present in the media samples (not shown). A number of protein bands were present in the week 3 culture medium (Figure 9A). However none of them were detected in western immunoblots with antibody Pa-3/4 (Figure 9B), presumably because all the fragments containing epitope CB11B were small and had migrated off the bottom of the gel.

10 In contrast, a number of fragments were detected in western immunoblotting with antibody AH8L1 and two of the fragments, TII-F1 and TII-F2, appeared as sharp, clearly defined bands with molecular weights of about 28kDA and 27kDA respectively (Figure 9C). Antibody AH9L2 detected no type II collagen fragments (Figure 9D) whilst antibody AH12L3 detected the same bands as AH8L1 (compare Figure 9E with 9C).

15 Similar results were obtained in four other experiments using media from a different cartilage culture in each case (not shown). Thus the only antibodies to detect type II collagen fragments by western blot were those to epitopes in the amino-terminal helical region of the $\alpha 1(\text{II})$ chain.

20 It was important to prove that antibodies AH8L1 and AH12L3 were detecting type II collagen fragments in these cultures and not some cross-reacting contaminant. To this end, the most abundant of the two sharp bands detected by the antibodies, TII-F1, was excised from a PVDF membrane and the first 16 residues of its amino terminal
25 sequence determined. The sequence had an initial yield of 17.2 pmol and was a 100% match for an internal sequence in the $\alpha 1(\text{II})$ chain. This proved that TII-F1 was indeed a type II collagen fragment and locates the amino-terminus as being at residue 223, which is within the sequence of peptide AH12 (Figure 10). Thus the epitopes detected by antibodies AH8L1 and AH12L3 are located very close to the amino-terminus of the
30 major detectable fragment.

EXAMPLE 11 - Development of a Sandwich ELISA For Type II Collagen Fragments Using Antibodies AH8L1 and AH12L3

5 Since epitopes AH8 and AH12 are separated by just 6 residues in the α 1(II) chain, it was important to determine if both antibodies would bind to the unwound α -chain at the same time, without causing steric hindrance to each other.

10 To this end, ELISA plates were coated with HDC, blocked, and then unlabelled antibody AH12L3 was bound to the collagen either as the antiserum or as a purified antibody. Biotinylated antibody AH8L1 was then added into the wells and its binding was detected using an avidin-peroxidase conjugate. The results (Figure 11) demonstrate that AH12L3 did not inhibit the binding of biotinylated AH8L1 to HDC.

15 A preliminary Sandwich ELISA was set up by coating unlabelled antibody AH12L3 onto the ELISA plates, incubating with HDC and then detecting with biotinylated antibody AH8L1 followed by avidin-peroxidase conjugate. HDC was detected by this assay and the lower detection limit was about 0.05 μ g/ml type II collagen (Figure 12A).

20 By comparison, the CB11B inhibition ELISA could only detect type II collagen with a lower detection limit of 50-100 μ g/ml (Figure 12B).

EXAMPLE 12: Immunostaining of osteoarthritic cartilage

25 (i) Immunohistochemistry

Cartilage pieces were embedded in OCT embedding medium (B.D.H. Laboratory Supplies, Poole, England) and sections 7 μ m thick cut and attached to slides pre-coated with 3-aminopropyltriethoxysilane (I.C.N. Biomedicals Ltd., Thame, England) as previously described (11), to ensure maximum adherence of the section for uniform staining. Sections were either stained immediately or stored at -20°C. Aldehyde groups were blocked with normal goat serum, diluted 1:10, and permeability of the extracellular matrix was maximised with Chondroitinase ABC lyase (I.C.N.) containing proteinase inhibitors. Sections were probed with Col2-3/4m, AH9L2 or AH12L3. Optimum dilutions were determined by matching the IgG concentration of the antibody

with that of a suitable control antibody. For Col2-3/4m, which is an IgG1, a mouse monoclonal was used of the same isotype but raised to an irrelevant epitope. For IgG purified from the rabbit anti-peptide antisera AH9L2 and AH12L3, a control IgG from non-immune rabbits (Vector Laboratories) was used. These control antibodies were
5 diluted to the highest concentration which produced negligible background staining of cartilage specimens. A biotin-avidin detection system was used. Sections were incubated with biotin-labelled secondary antibody, goat-anti-rabbit or mouse Ig(H+L) (Southern Biotechnology Associates), diluted 1:100. Bound antibody was detected with the ABC Elite biotin-streptavidin kit (Vector Laboratories) (avidin-biotin-peroxidase)
10 according to the manufacturer's directions and the peroxidase reaction was developed using 3,3'-diaminobenzidine (DAB) (Vector Laboratories), with the addition of nickel to form a grey-black stain. Sections were dehydrated through graded alcohols before mounting permanently with DPX (B.D.H.).

15 (ii) Results

Samples from a variety of different osteoarthritic and non-arthritic joints were analysed. All samples were stained with COL2-3/4m, AH12L3 and AH9L2. Figure 13 shows a typical example of OA femoral head cartilage. There were differences in the intensity
20 as well as the pattern of staining between the 3 antibodies. The results with mouse monoclonal Col2-3/4m were essentially as described previously (11). Staining was seen throughout the depth of the OA cartilage, with a thin band of intense staining at the articular surface and moderate staining extending into the mid-zone (Figure 13A). Deep zone chondrocytes exhibited strong pericellular staining (Figure 13D). Some
25 degree of interterritorial staining was seen in all zones. The non-immune mouse control is shown in Figure 13G for comparison. Rabbit polyclonal antibody AH12L3 gave very similar results to Col2-3/4m, although the staining intensity was weaker (Figure 13, B and E). In contrast, staining with rabbit polyclonal antibody AH9L2 was generally very weak in all zones (Figure 13, C and F). The intensity of staining with this
30 antibody was only marginally greater than with the non-immune control (Figure 13H).

In general, staining of the non-arthritic cartilages was far less intense. Figure 14 shows a typical example of non-arthritic femoral head cartilage. The pattern of staining was similar to that previously described (11). The interterritorial staining seen with

Col2-3/4m and AH12L3 was of a low intensity and restricted mainly to a band of staining at the articular surface (Figure 14, A and B). The extent and intensity of staining around chondrocytes was also much reduced. There was virtually a complete absence of staining with AH9L2, in most cases at the same level as the non-immune control (Figure 14C).

It can therefore be seen that the amino-terminal epitope, AH12, was detected by immunohistochemistry in OA cartilage whereas the carboxy-terminal epitope, AH9, was not. This suggests that the amino-terminal region is more gradually degraded and therefore is retained for longer in the tissue. This is further evidence for its relative stability compared to the carboxy-terminal region.

EXAMPLE 13: Production and characterization of a monoclonal antibody to the AH8L1 epitope

A monoclonal antibody was raised to the AH8 epitope for use with AH12L3 in a sandwich ELISA. BALB/c mice were immunized subcutaneously 5 times with KLH-conjugated AH8L1, 100µg of peptide per injection. The first injection was emulsified with Complete Freund's Adjuvant, subsequent injections in Incomplete Freund's Adjuvant. Splenocytes from all of the mice were pooled, fused to SP2/0 myeloma cells and a monoclonal antibody was prepared using conventional technology. A positive clone was chosen on the basis of the ability of its secreted antibody to react with AH8 and HDC by ELISA (as described above, using goat-anti-mouse Ig-alkaline phosphatase (Southern Biotechnology) as the second antibody). The chosen clone was expanded in a spinner flask, at the Sheffield Hybridoma Unit, Sheffield University. The resulting crude antibody preparation was applied to a Thiosorb column (Bioprocessing, Durham, UK) to purify the IgG. The isotype of the resulting preparation was determined as IgG1, using the Isostrip Mouse Monoclonal Antibody Isotyping Kit (Boehringer Mannheim). After dialysis into PBS, the concentration of the preparation was determined by reading the absorbance at 280nm (2.15mg/ml), and aliquots stored at -20°C.

An experiment was also carried out to ensure that the binding of AH8MAb to its epitope on HDC was not inhibiting the binding of AH12L3 to its own corresponding epitope on

the same molecule. AH12L3 and AH8MAb were each double diluted in carbonate buffer (see Methods) across rows of an HDC-coated Immulon-2 plate and allowed to passively bind to the plastic for 90 minutes at 37°C. Unbound antibody was removed with 3 washes in PBS-Tween. Double diluted AH12L3 was then added to one of the rows previously incubated with AH8MAb, and incubated a further 90 minutes at 37°C. PBS only was added to the remaining rows. After washing, secondary antibody was added; anti-mouse to the AH8MAb-only and AH8MAb + AH12L3 rows, and anti-rabbit to the AH12L3-only row, and incubated as above. After a final wash, alkaline phosphatase substrate was added to all wells, and the plate was read at 450nm.

10

AH8MAb was found to be specific for the AH8 peptide and HDC by ELISA, showing minimal cross-reactivity with AH12 and AH9 peptide. As with the AH8L1 polyclonal antibody, it was also found not to bind to type I, III or IV collagens, and was positive for the 3/4 piece of collagenase-cleaved type II collagen only, shown by Western Blotting.

15

AH8MAb also detected the same bands in week 3 medium from IL-1 α stimulated BNC as polyclonals AH8L1 and AH12L3 (data not shown).

EXAMPLE 14: AH8MAb/AH12L3 sandwich ELISA

20 (i) Preparation

All wells of an Immulon-2 plate were coated with 50 μ l AH8MAb at 1:80 (27 μ g/ml) and the antibody allowed to passively adsorb overnight at 4°C. Excess antibody was removed with 3 washes in azide-free PBS containing 0.1% Tween 20 (PBS-Tween).

25

Uncoated binding sites were blocked with 5% w/v skimmed milk powder (MarvelTM) in PBS, for 30 minutes at room temperature followed by 3 washes in PBS-Tween. To 4 wells were added 50 μ l of PBS, to determine the degree of non-specific binding. To duplicate wells were added purified native or denatured collagens. The native collagens were initially dissolved in 0.5M acetic acid and then dialyzed into 0.5M Tris HCl. Some aliquots were subsequently denature by heating at 80°C for 20 min.

30

Serum samples, diluted in PBS as required, were added in duplicate to test wells at 50 μ l/well. The plate was then incubated for 90 minutes at 37°C, before washing 3 times in PBS-Tween. Secondary antibody, AH12L3, was diluted to 1:500 in PBS containing 0.1% Tween 20 and 3% BSA, and 50 μ l added to all wells. After a further

incubation at 37°C for 90 minutes, the plate was washed as above and third antibody, peroxidase conjugated goat anti-rabbit Ig (Sigma Biosciences) was added to all wells at 1:1000 in PBS-Tween-BSA at 50µl/well, and incubated at 37°C for 90 minutes. After 3 more washes in PBS-Tween and a final wash in distilled water, peroxidase substrate, TMB-3,3',5,5'-tetramethylbenzidine (Kirkegaard and Perry Laboratories, Gaithersburg, Maryland, USA) added to all wells, 50µl/well, and the colour allowed to develop at room temperature for 20-30 minutes. The reaction was stopped with the addition of 50µl H₂SO₄, and the plate read at 450nm. The mean absorbance of the 4 non-specific binding wells was subtracted from that of all other wells.

10

(ii) Characterisation of antibodies for AH8MAb/AH12L3 sandwich ELISA

Epitopes AH8 and AH12 are located close to each other and so it was important to demonstrate that monoclonal A8MAb and polyclonal AH12L3 could both bind to denatured type II collagen at the same time as each other. Figure 15 demonstrates the ability of AH12L3 to bind to its epitope on HDC in the presence of previously-bound AH8MAb. It can be seen that there is no diminution of binding of AH12L3, as this curve is almost identical to that produced when AH12L3 is bound to HDC alone. This indicates that although the AH8 and AH12 epitopes are in close proximity to each other, both antibodies are able to bind to their respective epitopes, without interference from each other. This allows detection of fragments of type II collagen bearing these epitopes in serum or synovial fluid when assayed in the sandwich ELISA.

15

20

(iii) Establishment of standard curve for AH8MAb/AH12L3 sandwich ELISA

25

The standard curve achieved greatest linearity when both HDC concentration and absorbance were plotted on a log scale (Figure 16). Samples were appropriately diluted to fall within the limits of the standard curve.

30

(iv) Specificity of AH8MAb/AH12L3 sandwich ELISA for denatured type II collagen

Assay results for native and denatured type II collagen are shown in Figure 17. As expected, type II collagen is only detected in its denatured form, not when in the native conformation. In separate experiments, native or denatured collagen types I and III

were assayed using AH8MAb/AH12L3 sandwich ELISA but there was no recognition of these molecules in the assay (data not shown).

EXAMPLE 15: Measurement of type II collagen in serum

5

A variety of sera from non-arthritic laboratory personnel were collected and stored at -20°C until use. They were each assayed for type II collagen using the new AH8MAb/AH12L3 sandwich ELISA, over a range of dilutions. The results, shown in Figure 18, demonstrate that fragments of type II collagen containing the AH8 and
10 AH12 epitopes could be detected in most samples and the levels detected could be diluted out in a log-linear fashion. In comparison to the bovine HDC standard, the levels of type II collagen fragments in normal serum ranged from 0 to almost 600µM, with a mean of about 100µM (Figure 19).

15 EXAMPLE 16: Preparation of a synthetic peptide standard

While purified bovine type II collagen can be used as a standard for the assay, there may be batch to batch variation in this standard. Thus, a 50-residue peptide which contains both epitopes AH8 and AH12 was synthesised. The sequence is shown in
20 Figure 20. This standard may be used in assays designed to monitor disease-related changes in serum-levels of type II collagen fragments.

REFERENCES

- 25 1. Poole, A.R. 1993. Cartilage in health and disease. In Arthritis and Allied Conditions: A Textbook of Rheumatology. D.J. McCarty and W.J. Koopman, editors. Lea & Febiger, Philadelphia. 279-333.
2. Eyre, D.R., M.A. Paz, and P.M. Gallop. 1984. Cross-linking in collagen and
30 elastin. Annu. Rev. Biochem. 53:717-748.
3. Buttle, D.J., H. Bramwell, and A.P. Hollander. 1995. Proteolytic mechanisms of cartilage breakdown: a target for arthritis therapy? J. Clin. Pathol. :Mol. Pathol. 48:M167-M177.

4. Hollander, A.P., R.M. Atkins, D.M. Eastwood, P.A. Dieppe, and C.J. Elson. 1991. Degradation of human cartilage by synovial fluid but not cytokines *in vitro*. *Ann. Rheum. Dis.* 50:57-58.
- 5
5. Hollander, A.P., R.M. Atkins, D.M. Eastwood, P.A. Dieppe, and C.J. Elson. 1991. Human cartilage is degraded by rheumatoid arthritis synovial fluid but not by recombinant cytokines *in vitro*. *Clin. Exp. Immunol.* 83:52-57.
- 10
6. Venn, M. and A. Maroudas. 1977. Chemical composition and swelling of normal and osteoarthritic femoral head cartilage. *Ann. Rheum. Dis.* 36:121-129.
7. Mankin, H.J., H. Dorfman, L. Lippiello, and A. Zarins. 1971. Biochemical and metabolic abnormalities in articular cartilage from osteo-arthritic human hops. *J. Bone*
- 15 *Joint Surg.* 53A:523-537.
8. Dodge, G.R. and A.R. Poole. 1989. Immunohistochemical detection and immunochemical analysis of type II collagen degradation in human normal, rheumatoid, and osteoarthritic articular cartilages and in explants of bovine articular
- 20 cartilage cultured with interleukin-1. *J. Clin. Invest.* 83:647-661.
9. Dodge, G.R., I. Pidoux, and A.R. Poole. 1991. The degradation of type II collagen in rheumatoid arthritis: An immunoelectron microscope study. *Matrix* 11:330-338.
- 25
10. Hollander, A.P., T.F. Heathfield, C. Webber, Y. Iwata, R. Bourne, C. Rorabeck, and A.R. Poole. 1994. Increased damage to type II collagen in osteoarthritic articular cartilage detected by a new immunoassay. *J. Clin. Invest.* 93:1722-1732.
- 30
11. Hollander, A.P., I. Pidoux, A. Reiner, C. Rorabeck, R. Bourne, and A.R. Poole. 1995. Damage to type II collagen in aging and osteoarthritis starts at the articular surface, originates around chondrocytes, and extends into the cartilage with progressive degeneration. *J. Clin. Invest.* 96:2859-2869.

12. Ellis, A.J., V.A. Curry, E.K. Powell, and T.E. Cawston. 1994. The prevention of collagen breakdown in bovine nasal cartilage by TIMP, TIMP-2 and a low molecular weight synthetic inhibitor. *Biochem. Biophys. Res. Commun.* 201:94-101.
- 5 13. Cawston, T.E., A.J. Ellis, G. Humm, E. Lean, D. Ward, and V. Curry. 1995. Interleukin-1 and oncostatin M in combination promote the release of collagen fragments from bovine nasal cartilage culture. *Biochem. Biophys. Res. Commun.* 215:377-385.
- 10 14. Kozaci, L.D., D.J. Buttle, and A.P. Hollander. 1996. Degradation of type II collagen, but not proteoglycan, correlates with matrix metalloproteinase activity in cartilage explant cultures. *Arthritis Rheum.* (In Press).
- 15 15. Sandy, J.D., C.R. Flannery, P.J. Neame, and L.S. Lohmander. 1992. The structure of aggrecan fragments in human synovial fluid. *J. Clin. Invest.* 89:1512-1516.
16. Lohmander, L.S., P.J. Neame, and J.D. Sandy. 1993. The structure of aggrecan fragments in human synovial fluid. *Arthritis Rheum.* 36:1214-1222.
- 20 17. Poole, A.R., M. Ionescu, A. Swan, and P.A. Dieppe. 1994. Changes in cartilage metabolism in arthritis are reflected by altered serum and synovial fluid levels of the cartilage proteoglycan aggrecan. *J. Clin. Invest.* 94:25-33.
- 25 18. Lohmander, L.S. 1995. The release of aggrecan fragments into synovial fluid after joint injury and in osteoarthritis. *J. Rheumatol.* 22 (suppl. 43):75-77.
- 30 19. Roos, H., T. Adalberth, L. Dahlberg, and L.S. Lohmander. 1995. Osteoarthritis of the knee after injury to the anterior cruciate ligament or meniscus: the influence of time and age. *Osteoarthritis and Cartilage* 3:261-267.
20. Poole, A.R., C. Webber, A. Reiner, and P.J. Roughley. 1989. Studies of a monoclonal antibody to skeletal keratan sulphate. Importance of valency. *Biochem. J.* 260:849-856.

21. Slater Jr., R.R., M.T. Bayliss, P.F. Lachiewicz, D.M. Visco, and B. Caterson. 1995. Monoclonal antibodies that detect biochemical markers of arthritis in humans. *Arthritis Rheum.* 38:655-659.
- 5
22. Poole, A.R. 1994. Immunochemical markers of joint inflammation, skeletal damage and repair: where are we now? *Ann. Rheum. Dis.* 53:3-5.
23. Ayad, S., R.P. Boot-Handford, M.J. Humphries, K.E. Kadle, and C.A. Shuttleworth. 1994. *The Extracellular Matrix Facts Books.* Academic Press, London.
- 10
24. Buttle, D.J., J. Saklatvala, M. Tamai, and A.J. Barrett. 1992. Inhibition of interleukin 1-stimulated cartilage proteoglycan degradation by a lipophilic inactivator of cysteine endopeptidases. *Biochem. J.* 281:175-177.
- 15
25. Buttle, D.J., C.J. Handley, M.Z. Ilic, J. Saklatvala, M. Murata, and A.J. Barrett. 1993. Inhibition of cartilage proteoglycan release by a specific inactivator of cathepsin B and an inhibitor of matrix metalloproteinases. *Arthritis Rheum.* 36:1709-1717.
- 20
26. Cawston, T.E. 1993. Blocking cartilage destruction with metalloproteinase inhibitors: a valid therapeutic target? *Ann. Rheum. Dis.* 52:769-770.
27. Dunbar, B. and S.B. Wilson. 1994. A buffer exchange procedure giving enhanced resolution to polyacrylamide gels prerun for protein sequencing. *Anal. Biochem.* 216:227-228.
- 25
28. Rucklidge, G.J., G. Milne, S.M. Chaudhry, and S.P. Robins. 1997. Preparation of affinity-purified antibodies for enzyme linked immunoassays using blotting membrane as an antigen support. *Anal. Biochem.* (In Press)
- 30

CLAIMS:

1. An immunoassay kit comprising a first antibody (e.g. a monoclonal antibody, polyclonal antibody or fragment or derivative thereof) which binds to a first epitope
5 and a second antibody (e.g. a monoclonal antibody, polyclonal antibody or fragment or derivative thereof) which binds to a second epitope, wherein the first and second epitopes are C-II_{free} coupled epitopes.
2. The immunoassay kit of claim 1 for use in therapy, diagnosis, prognosis or
10 candidate drug screening.
3. The immunoassay kit of claim 1 or claim 2 for use in Sandwich immunoassay (e.g. for use in Sandwich ELISA).
- 15 4. The immunoassay kit of any one of the preceding claims wherein the C-II_{free} is systemic C-II_{free} (for example, serum C-II_{free}, urine C-II_{free} or synovial C-II_{free}).
5. The immunoassay kit of any one of the preceding claims wherein the coupled epitopes comprise (or are located within) an amino acid sequence from the N-
20 terminal region of the α 1 type II collagen chain (for example the N-terminal cross-linked region of the triple helix thereof).
6. The immunoassay kit of any one of the preceding claims wherein the coupled epitopes can simultaneously bind cognate antibodies and/or are disposed such that
25 an antibody bound at the first epitope does not sterically hinder antibody binding at the second epitope.
7. The immunoassay kit of any one of the preceding claims wherein the coupled epitopes comprise a conformational and/or continuous epitope.
30
8. The immunoassay kit of any one of the preceding claims wherein the coupled epitopes are separated by at least 2 amino acids, e.g. by at least 3, 4, 5, 6, 7, 8, 9, 10, 11, 12, 13, 14, 15, 16, 17, 18, 19 or 20 amino acids.

9. The immunoassay kit of any one of the preceding claims wherein the first antibody is immobilized on a solid support and/or the second antibody is labelled.

10. The immunoassay kit of claim 9 wherein the label is biotin.

5

11. The immunoassay kit of claim 9 wherein the label is a radioactive label or an enzyme label (e.g. alkaline phosphatase or peroxidase).

12. The immunoassay kit of claim 10 further comprising enzyme labelled avidin.

10

13. The immunoassay kit of any one of the preceding claims wherein the first antibody is an anti-AH8 antibody (e.g. AH8MAb or AH8L1) and the second antibody is an anti-AH12 antibody (e.g. AH12L3), or wherein the first antibody is an anti-AH12 antibody (e.g. AH12L3) and the second antibody is an anti-AH8 antibody (e.g.

15

AH8MAb or AH8L1).

14. The immunoassay kit of any one of claims 1-12 wherein the first antibody is an antibody which competitively inhibits binding of AH8MAb or AH8L1 to cognate epitope and the second antibody is an antibody which competitively inhibits binding of AH12L3 to cognate epitope, or wherein the first antibody is an antibody which competitively inhibits binding of AH12L3 to cognate epitope and the second antibody is an antibody which competitively inhibits binding of AH8MAb or AH8L1 to cognate epitope.

20

15. The immunoassay kit of any one of claims 1-12 wherein the first antibody is an antibody having the same (or essentially the same) epitope specificity as antibody AH8MAb or AH8L1 and the second antibody is an antibody having the same (or essentially the same) epitope specificity as antibody AH12L3, or wherein the first antibody is an antibody having the same (or essentially the same) epitope specificity as antibody AH12L3 and the second antibody is an antibody having the same (or essentially the same) epitope specificity as antibody AH8MAb or AH8L1.

25

30

16. The immunoassay kit of any one of claims 1-12 wherein the first and/or second antibody is a binding agent comprising the variable region (or a functional derivative

thereof) of antibody AH8MAb, AH8L1 or AH12L3, for example a Fab or Fab' fragment.

- 5 17. An antibody (e.g. a monoclonal antibody, polyclonal antibody, or fragment or derivative thereof) which binds to a coupled epitope of C-II_{free}.
18. The antibody of claim 17 which is labelled (e.g. with biotin or a radioactive label) and/or immobilized (e.g. on a solid support).
- 10 19. The antibody of claim 17 or 18 for use in the kit of any one of claims 1-16, the method of any one of claims 26-28 or process of any one of claims 29-33.
20. An anti-AH12 antibody (e.g. AH12L3) or an anti-AH8 antibody (e.g. AH8MAb or AH8L1).
- 15 21. An antibody which competitively inhibits binding of AH8MAb, AH8L1 or AH12L3 to cognate epitope.
22. An antibody having the same (or essentially the same) epitope specificity as antibody AH8MAb, AH8L1 or AH12L3.
- 20 23. A binding agent comprising the variable region (or a functional derivative thereof) of antibody AH8MAb, AH8L1 or AH12L3, for example a Fab or Fab' fragment.
- 25 24. A bifunctional heteroantibody comprising a first binding moiety which binds to a first epitope and a second binding moiety which binds to a second epitope, wherein the first and second epitopes are C-II_{free} coupled epitopes.
- 30 25. An immunoassay kit comprising the antibody or binding agent of any one of claims 17-24.
26. A method (e.g. a Sandwich ELISA) for assaying for C-II_{free} in a biological sample (e.g. a sample of serum, urine or SF) comprising contacting the sample with a first

antibody which binds to a first epitope and with a second antibody which binds to a second epitope, wherein the first and second epitopes are C-II_{free} coupled epitopes.

27. The method of claim 26 wherein:

- 5 (a) the first antibody is immobilized; and/or
(b) the second antibody is labelled; and/or
(c) the antibodies are as defined in any one of claims 1-22; and/or
(d) the coupled epitopes are as defined in any one of claims 5-8; and/or
(e) the C-II_{free} is as defined in claim 4; and/or
10 (f) the antibodies are provided as part of an immunoassay kit as defined in any one of claims 16.

28. An *in vitro* or *ex vivo* method of therapy, diagnosis or prognosis comprising the step of assaying a biological sample for C-II_{free} according to the method of claim 26
15 or 27.

29. A process for measuring the therapeutic activity of an agent comprising the steps of:

- (a) providing a sample derived from a subject treated with the agent; and
20 (b) assaying the sample for C-II_{free} using the kit of any one of claims 1-16, the antibody/binding agent of any one of claims 17-24 or the method of any one of claims 26-27),

wherein the amount of C-II_{free} in the sample assayed in step (b) is used as an index of therapeutic activity.

25

30. A process for producing a therapeutic agent comprising the step of screening a library of candidate therapeutic agents for therapeutic activity using the process of claim 29.

30 31. A process for producing a therapeutic agent comprising the steps of :

- (a) selecting a chemical formula on the basis of the structural features of a therapeutic agent produced by the process of claim 30;
(b) producing (e.g. by synthesis or isolation) a therapeutic agent having the chemical formula selected in step (a).

32. A therapeutic obtainable by (or obtained by) the process of claim 30 or 31.
33. The process of any one of claims wherein the therapeutic agent is an anti-
5 arthritic drug or MMP inhibitor.
34. A cell or cell line which expresses the antibody or binding agent of any one of claims 17-24.
- 10 35. A process for producing an antibody which binds to a coupled epitope of C-II_{free} comprising the steps of:
- (a) degrading type II collagen *in vitro* to produce a plurality of fragments;
 - (b) fractionating the fragments on the basis of size;
 - 15 (c) identifying relatively large fragments;
 - (d) screening the relatively large fragments for the presence of multiple epitopes;
 - (e) selecting a fragment which bears two or more epitopes;
 - (f) raising antibodies against the fragment selected in step (e).
- 20 36. An antibody which binds to a coupled epitope of C-II_{free} obtainable (or obtained by) the process of claim 35.
37. Isolated type II collagen fragment bearing two or more epitopes for use in step
25 (f) of the process of claim 35, the fragment for example comprising (or consisting essentially of) an amino acid sequence from the N terminal region of the type II collagen α 1 peptide (for example from the N terminal cross-linked region of the triple helix thereof).
- 30 38. The fragment of claim 37 which comprises (or consists essentially of) a sequence of 10-60 (e.g. about 50) amino acids from the N terminal region of the type II collagen α 1 peptide (for example from the N terminal cross-linked region of the triple helix thereof).

FIG. 1

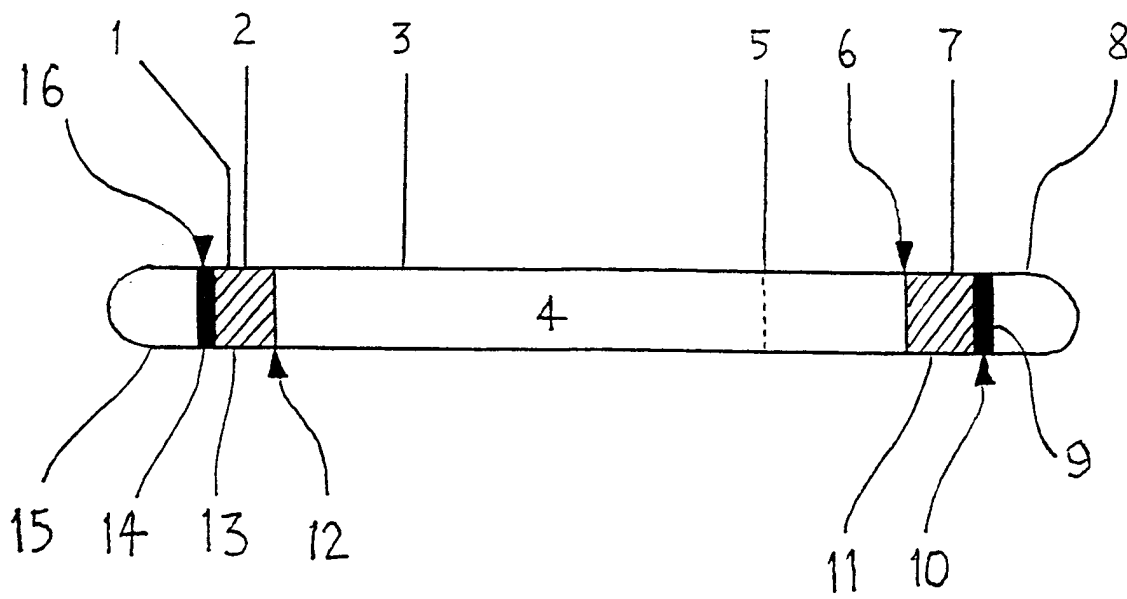

2/20

1	MIRLGAPQSL	VLLTLLVAAV	LRCQGQDVQE	AGSCVQDGQR	YNDKDVWKPE
51	PCRICVCDTG	TVLCDDIICE	DVKDCLSP EI	PFGECCPICP	TDLATASGQP
101	GPKGQKGEPG	DIKDIVGPKG	PPGPQGPAGE	QGPRGDRGDK	GEKGAPGPRG
151	RDGEPGTLGN	PGPPGPPGPP	GPPGLGGNFA	AQMAGGFDEK	AGGAQLGVMQ
201	GPMGPMGPRG	PPGPAGAPGP	QGFQGNPGEF	GEPGVSGPMG	PRGPPGPPGK
251	PGDDGEAGKP	GKAGERGPPG	PQGARGFPGT	PGLPGVKGHR	GYPGLDGAKG
301	EAGAPGVKGE	SGSPGENGSP	GPMGPRGLPG	ERGRTGPAGA	AGARGNDGQP
351	GPAGPPGPVG	PAGGPGFPGA	PGAKGEAGPT	GARGPEGAQG	PRGEPGTPGS
401	PGPAGASGNP	GTDGIPGAKG	SAGAPGIAGA	PGFPGPRGPP	DPQGATGPLG
451	PKGQTGKPGI	AGFKGEQGPK	GEPGPAGPQG	APGPAGEEGK	RGARGEPPGV
501	GPIGPPGERG	APGNRGFPQG	DGLAGPKGAP	GERGPSGLAG	PKGANGDPGR
551	PGEPGLPGAR	GLTGRPGDAG	PQKQVGPSSA	PGEDGRPGPP	GPQGARGQPG
601	VMGFPGPKGA	NGEPGKAGEK	GLPGAPGLRG	LPGKDGETGA	EGPPGPAGPA
651	GERGEQGAPG	PSGFQGLPGP	PGPPGEGGKP	GDQGVPGEAG	APGLVGPGE
701	RGFPGERGSP	GAQGLQGPRG	LPGTPTDGP	KGASGPAGPP	GAQGPGLQG
751	MPGERGAAGI	AGPKGDRGDV	GEKGPEGAPG	KDGRGLTGP	IGPPGPAGAN
801	GEKGEVGPFG	PAGSAGARGA	PGERGETGPP	GTSGIAGPPG	ADGQPGAKGE
851	QGEAGQKQDA	GAPGPQGPSG	APGPQGPPTG	TGPKGARGAQ	GPPGATGFPG
901	AAGRVGPPGS	NGNPGPPGPP	GPSKDGPKG	ARGDSGPPGR	AGEPGLQSPA
951	GPPGEKGEFG	DDGPSGAEGP	PGPQGLAGQR	GIVGLPGQRG	ERGFPLPGP
1001	SGEPGQQGAP	GASGDRGPPG	PVGPPLTGP	AGEPREGSP	GADGPPGRDG
1051	AAGVKGDRGE	TGAVGAPGAP	GPPGSPGPAG	PTGKQDRGE	AGAQGPMPGS
1101	GPAGARGIQG	PQPRGDKGE	AGEPGERGLK	GHRGFTGLQG	LPPPGPSGD
1151	QGASGPAGPS	GPRGPPGPVG	PSGKDGANGI	PGPIGPPGPR	GRSGETGPAG
1201	PPGNPFPFGP	PGPPGPGIDM	SAFAGLGPRE	KGPDPLQYMR	ADQAAGGLRQ
1251	HDAEVDATLK	SLNNQIESIR	SPEGSRKNPA	RTCRDLKLCH	PEWKSQDYWI
1301	DPNQGCTLDA	MKVFCNMETG	ETCVYPNPAN	VPKKNWSSK	SKEKKHIWFG
1351	ETINGGFHFS	YGDDNLAQNT	ANVQMTFLRL	LSTEGSQNIT	YHCKNSIAYL
1401	DEAAGNLKKA	LLIQGSNDVE	IRAEGNSRFT	YTALKDGCTK	HTGKWKQTVI
1451	EYRSQKTSRL	PIIDIAPMDI	GGPEQEFQVD	IGPVCFL	

FIG. 2

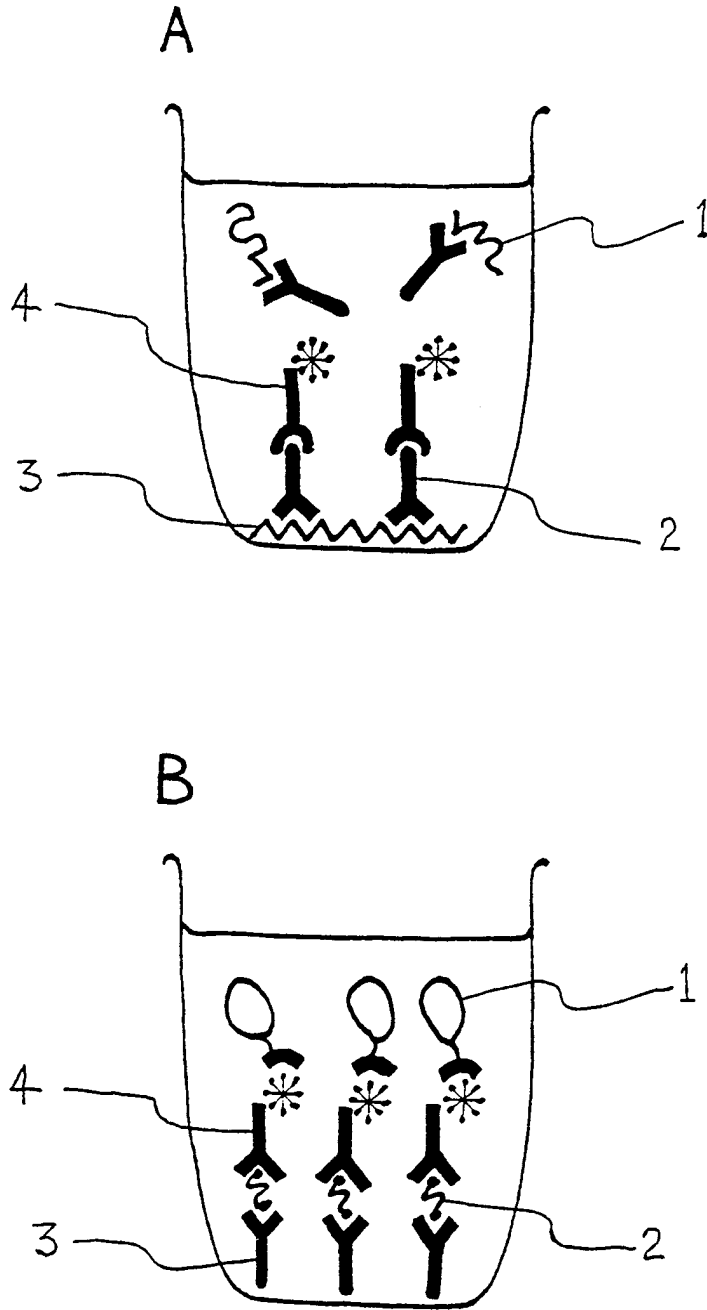

FIG. 3

4/20

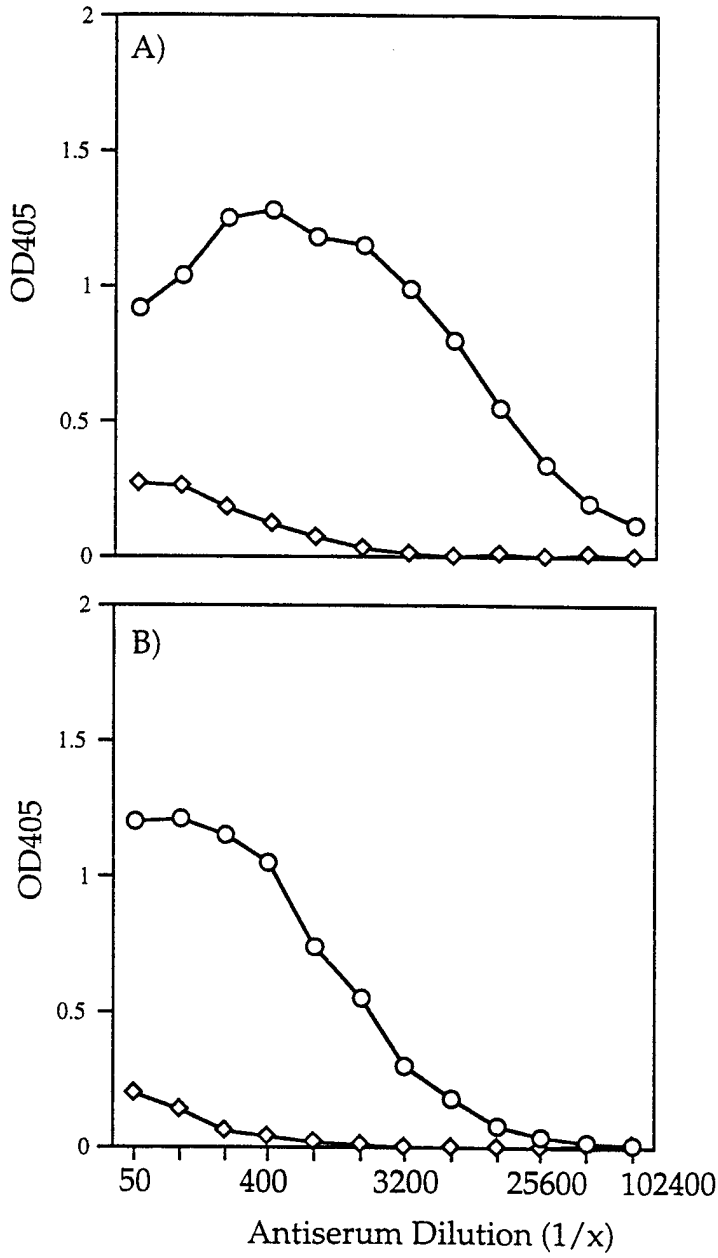

FIG 4

5/20

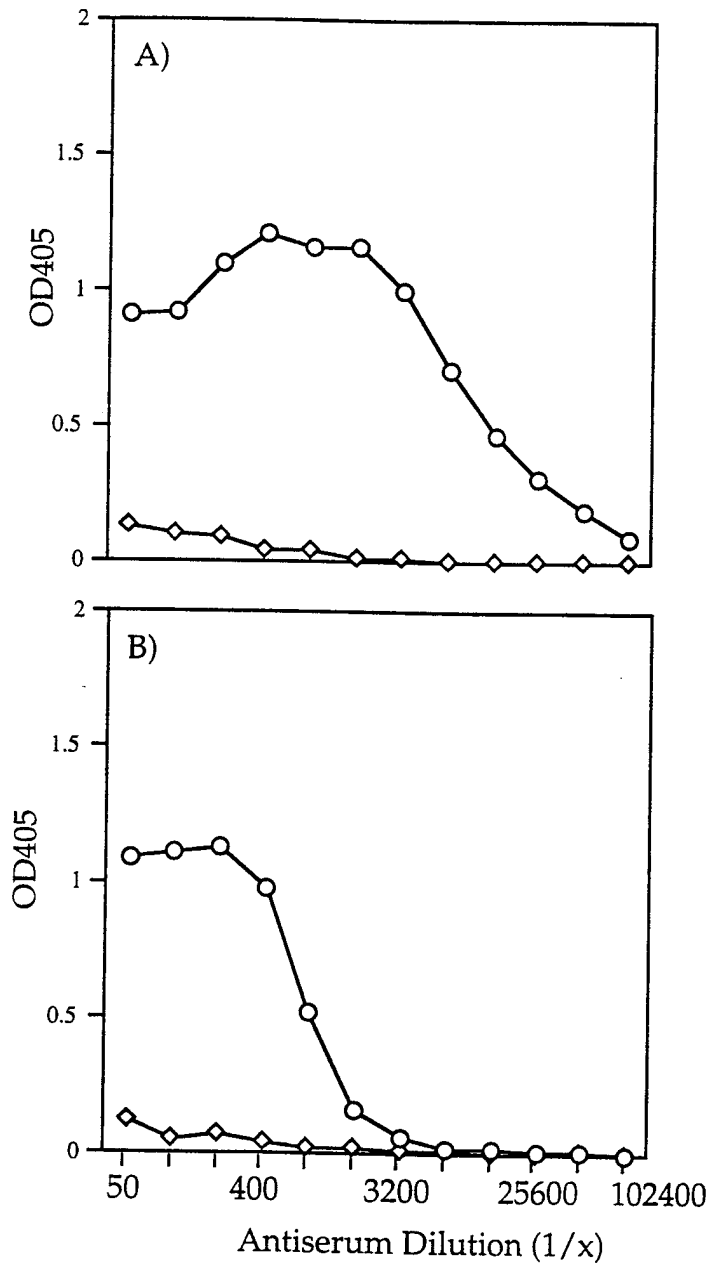

FIG. 5

6/20

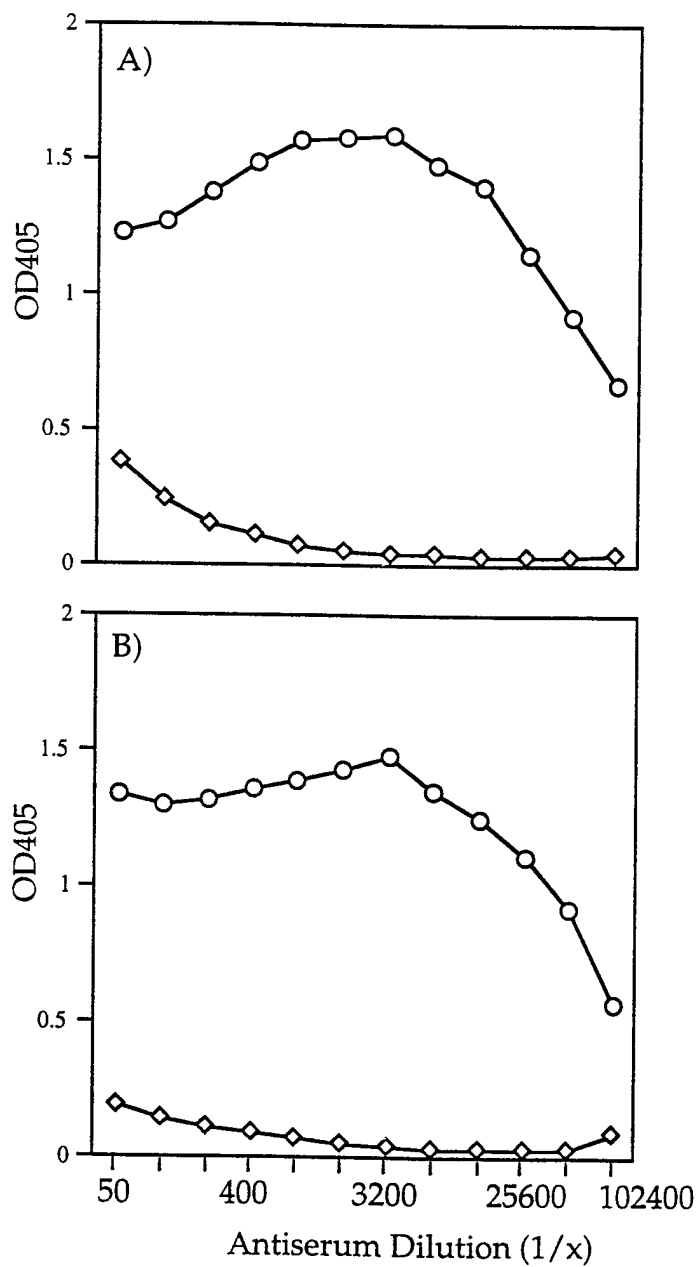
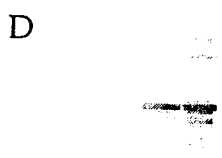
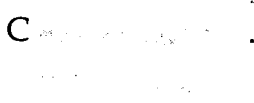
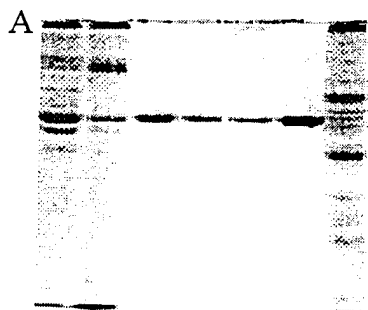

FIG. 6

7/20

FIG. 7



1 2 3 4 5 6 7

FIG. 8

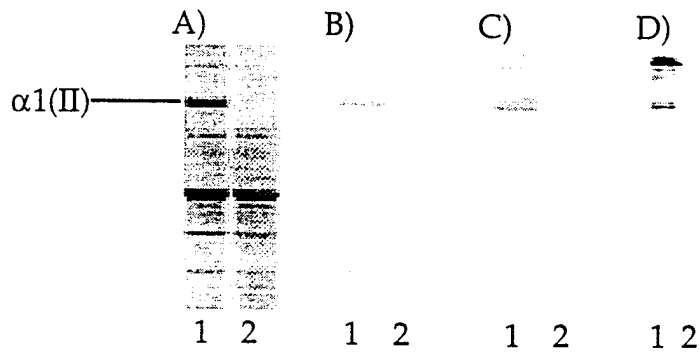
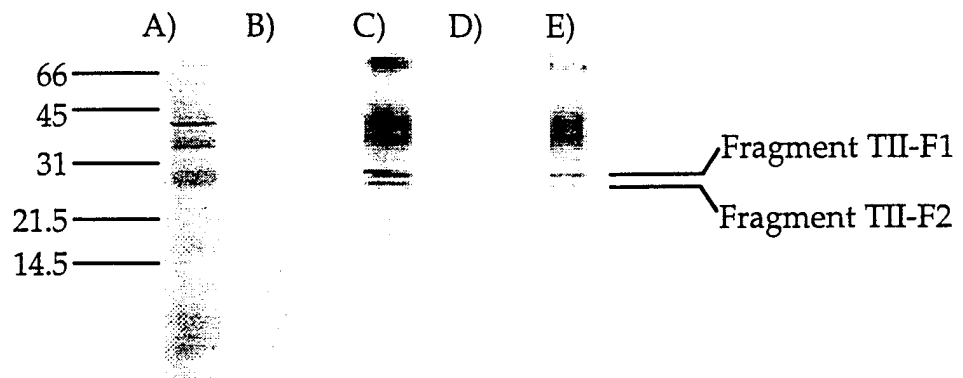
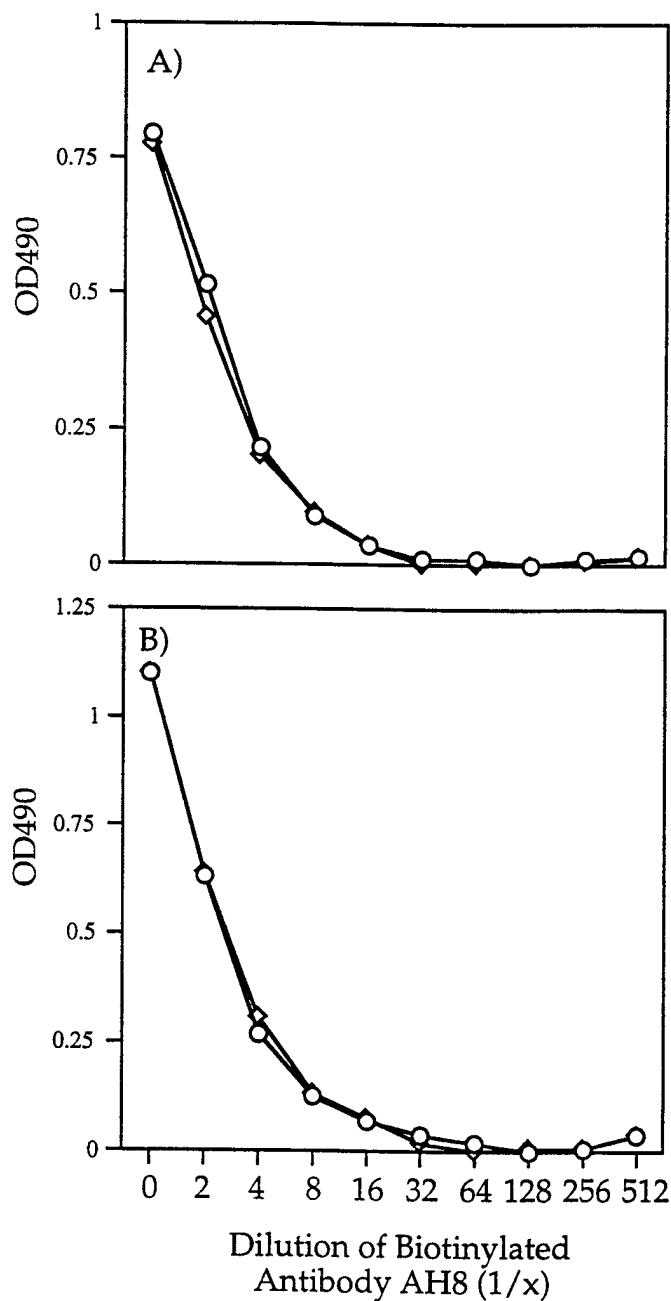

FIG. 9



11/20

FIG. 11



12/20

FIG. 12

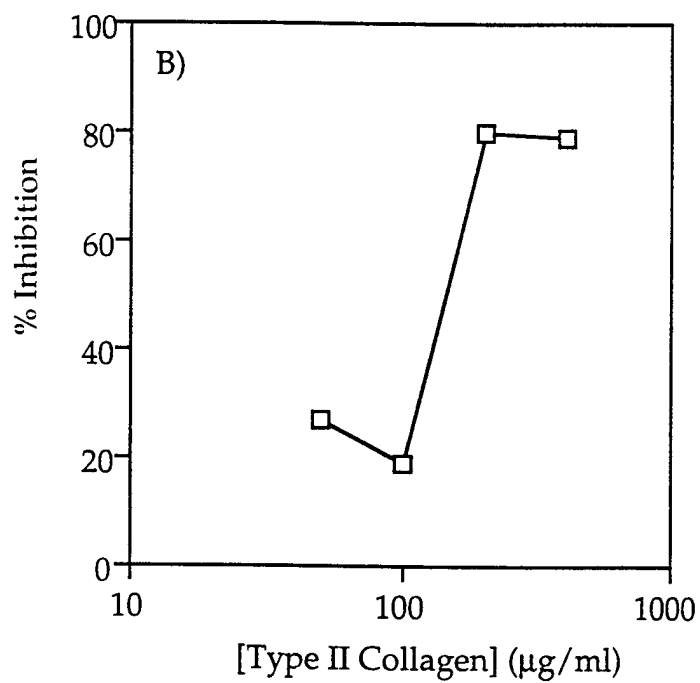
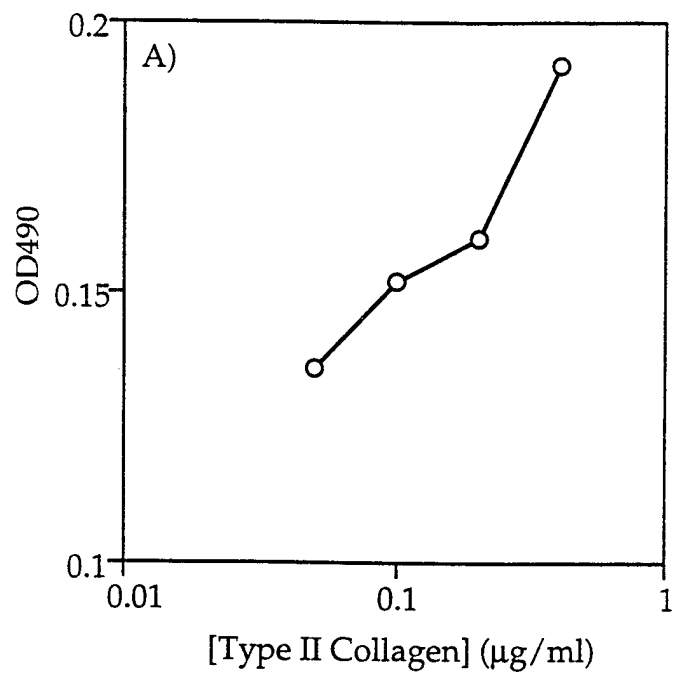

13/20

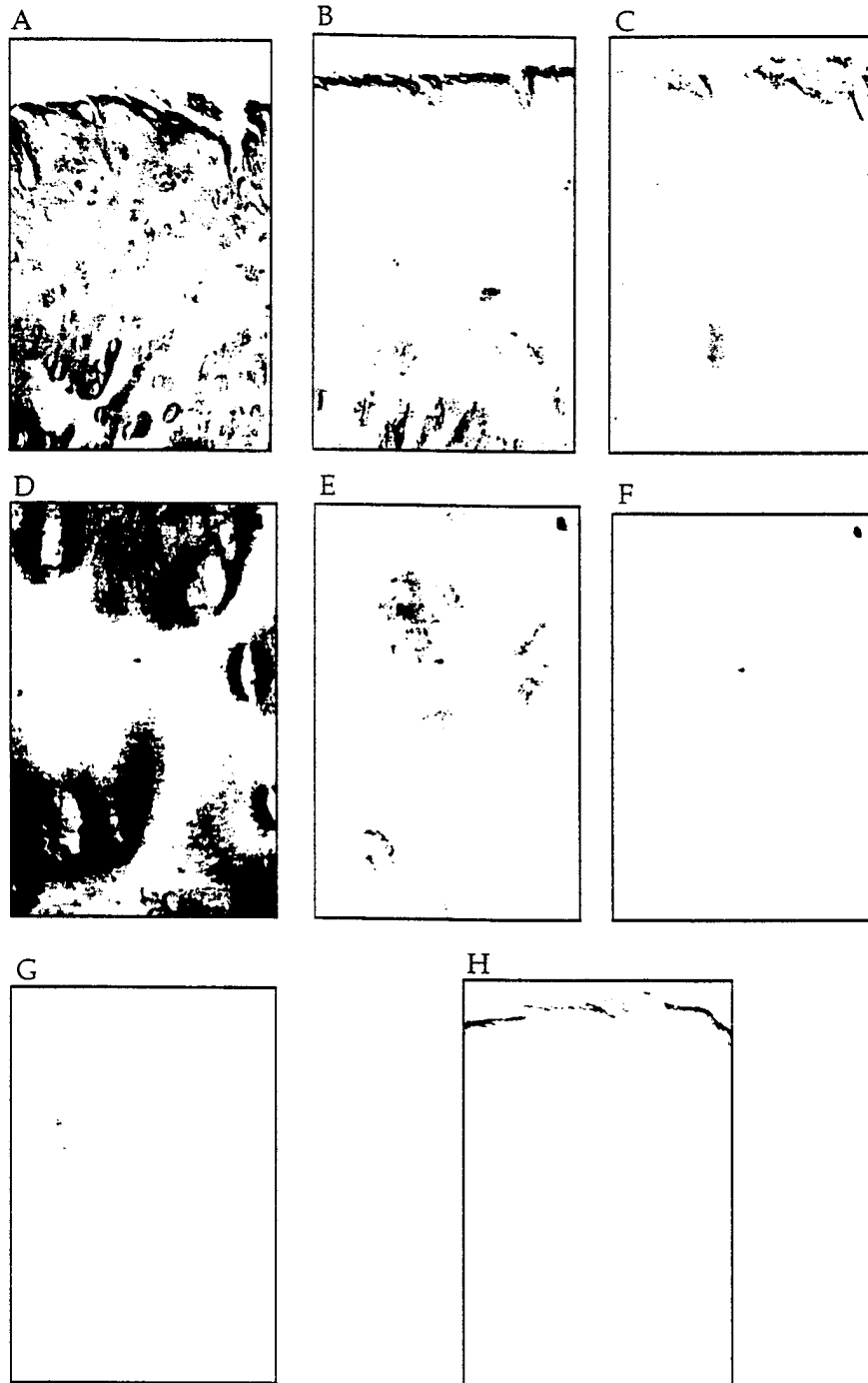

FIG. 13

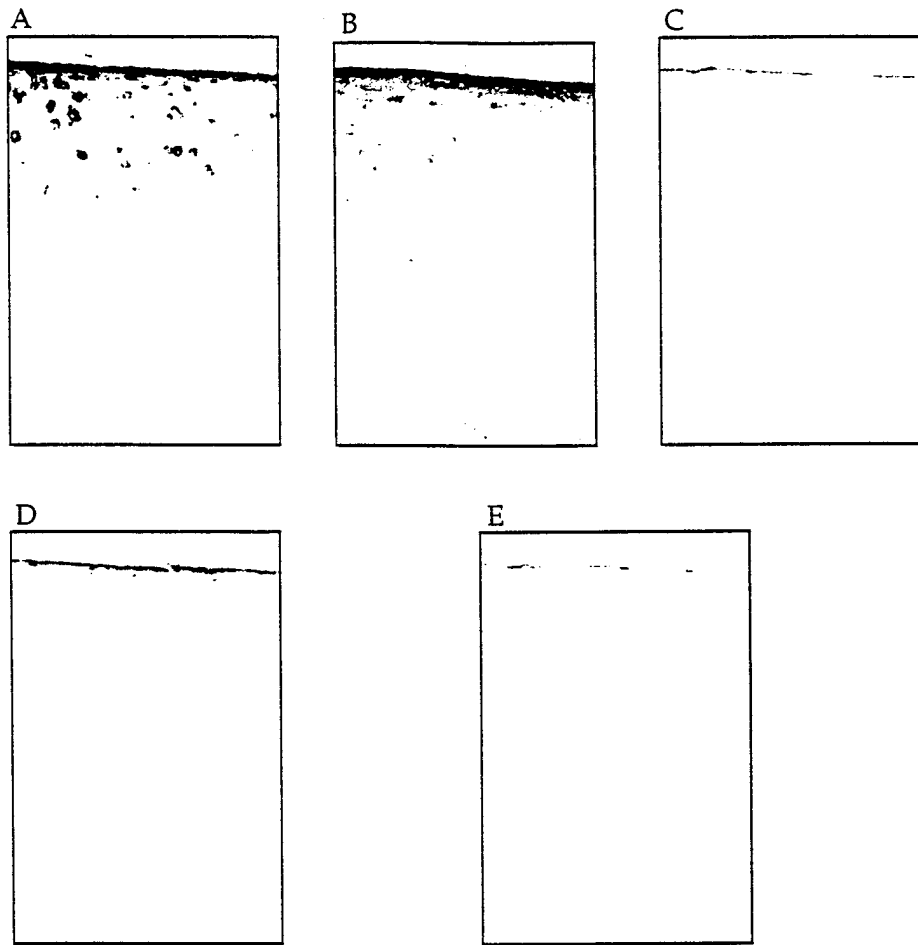
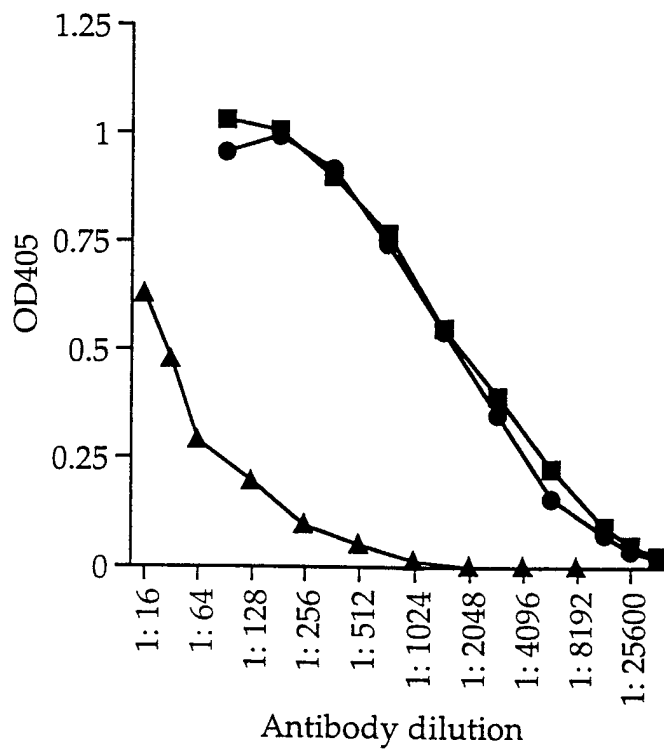

FIG. 14

FIG. 15



16/20

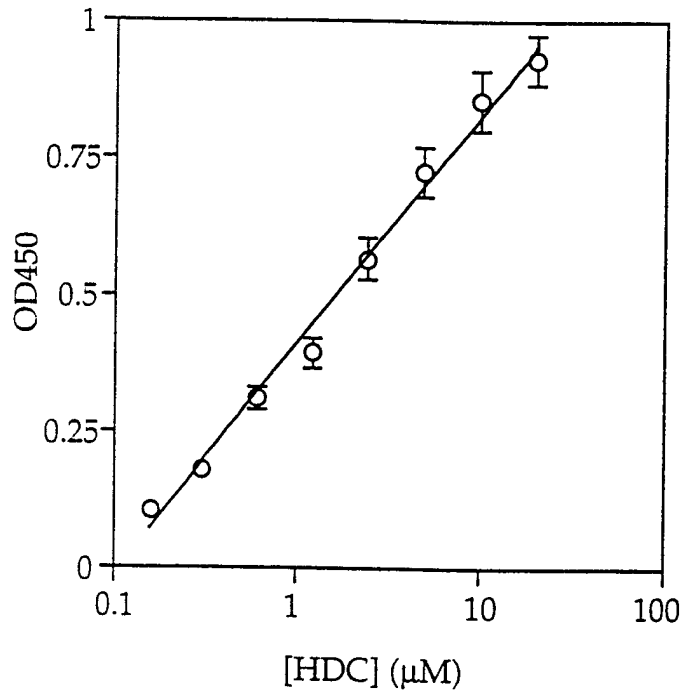

FIG. 16

17/20

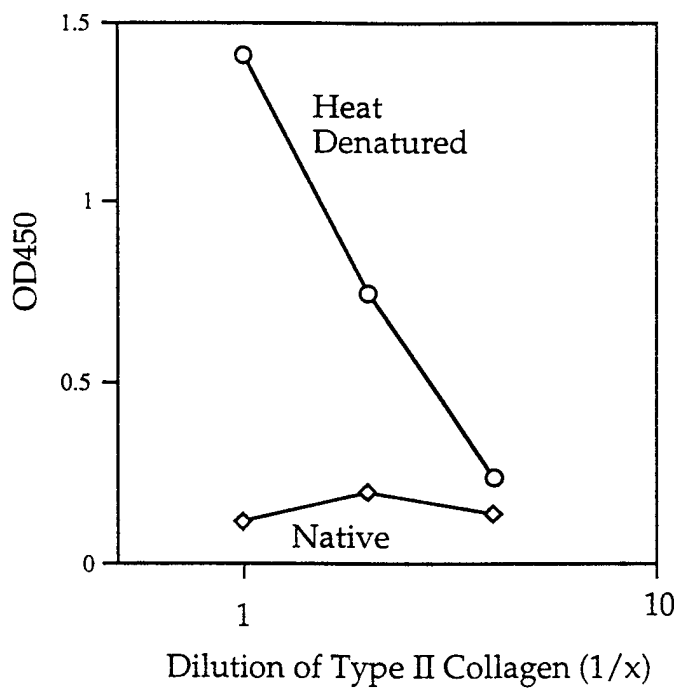

FIG. 17

18/20

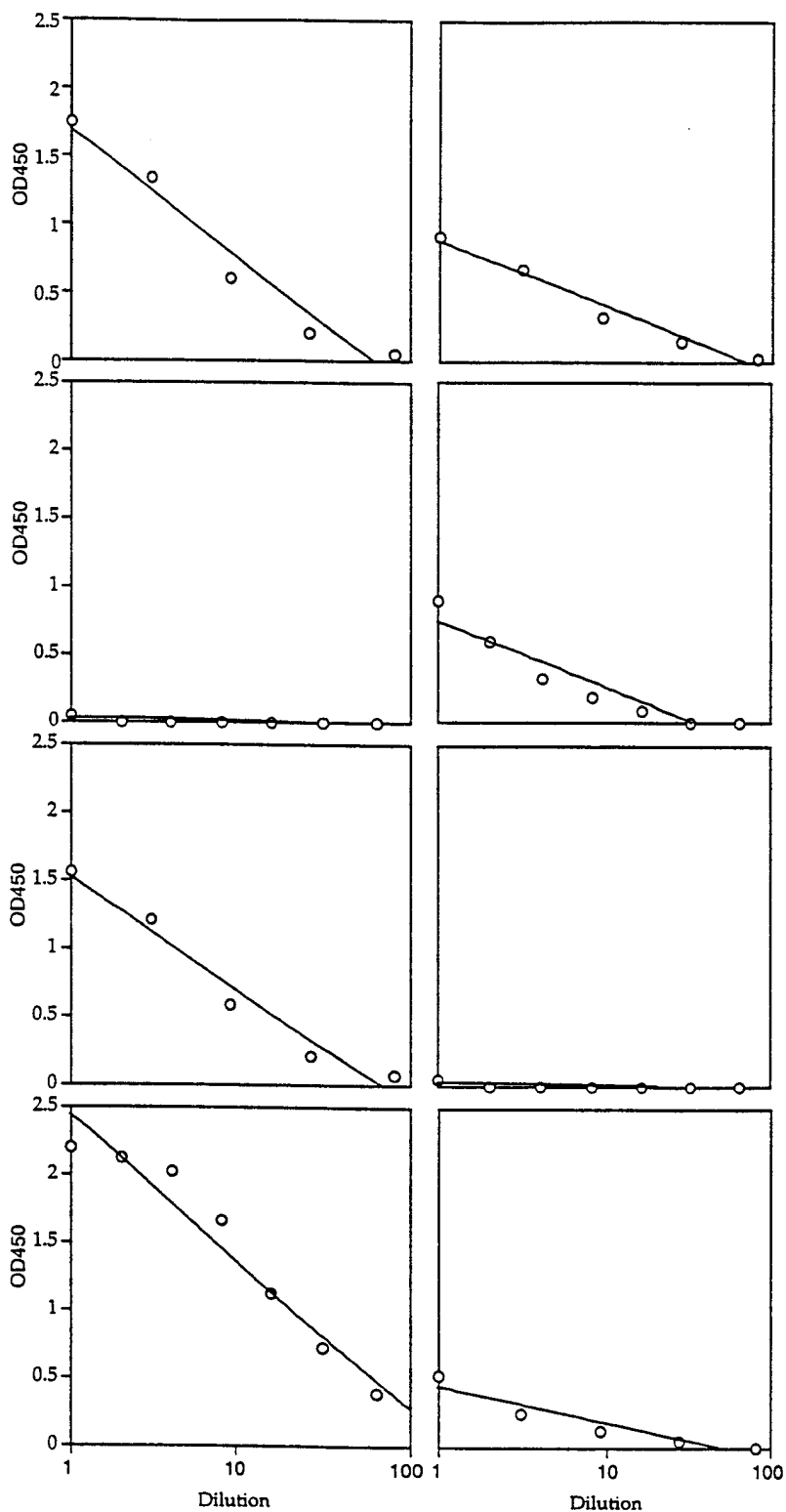

FIG. 18

19/20

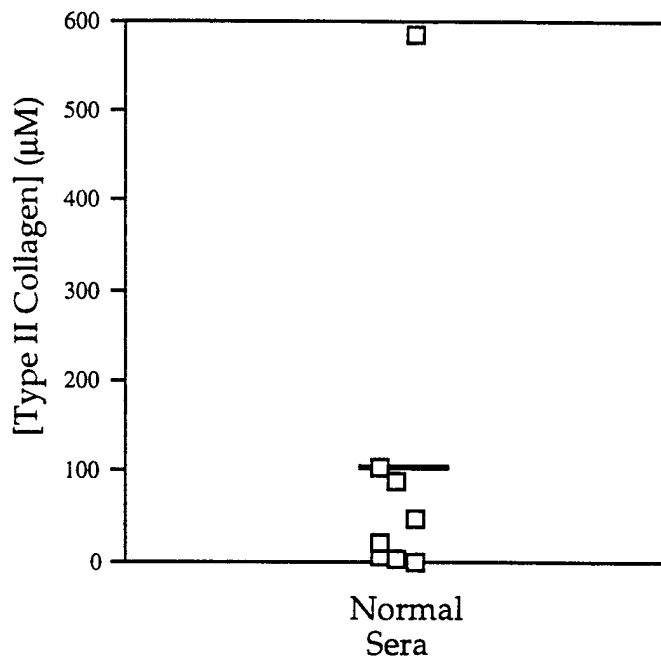

FIG. 19

20/20

¹A-G-A-P(OH)-G-P-Q-G-F-Q¹⁰-

¹¹G-N-P(OH)-G-E-P(OH)-G-E-P(OH)-G²⁰-

²¹V-S-G-P-M-G-P-R-G-P³⁰-

³¹P(OH)-G-P-P(OH)-G-K-P(OH)-G-D-D⁴⁰-

⁴¹G-E-A-G-K-P-G-K-A-G⁵⁰

FIG. 20

INTERNATIONAL SEARCH REPORT

International Application No

PCT/GB 98/00304

A. CLASSIFICATION OF SUBJECT MATTER

IPC 6 G01N33/577 G01N33/68 C07K16/18 C07K16/46 C12P21/08
 C07K14/78 C12N5/20

According to International Patent Classification (IPC) or to both national classification and IPC

B. FIELDS SEARCHED

Minimum documentation searched (classification system followed by classification symbols)

IPC 6 C07K

Documentation searched other than minimum documentation to the extent that such documents are included in the fields searched

Electronic data base consulted during the international search (name of data base and, where practical, search terms used)

C. DOCUMENTS CONSIDERED TO BE RELEVANT

Category ^o	Citation of document, with indication, where appropriate, of the relevant passages	Relevant to claim No.
A	WO 94 14070 A (SHRINERS HOSPITALS FOR CRIPPLED CHILDREN) 23 June 1994 see examples see claims see sequence listing ---	1-38
A	WO 94 18563 A (RHODE ISLAND HOSPITAL ET AL.) 18 August 1994 see the whole document --- -/--	1-38

Further documents are listed in the continuation of box C.

Patent family members are listed in annex.

^o Special categories of cited documents :

- "A" document defining the general state of the art which is not considered to be of particular relevance
- "E" earlier document but published on or after the international filing date
- "L" document which may throw doubts on priority claim(s) or which is cited to establish the publication date of another citation or other special reason (as specified)
- "O" document referring to an oral disclosure, use, exhibition or other means
- "P" document published prior to the international filing date but later than the priority date claimed

- "T" later document published after the international filing date or priority date and not in conflict with the application but cited to understand the principle or theory underlying the invention
- "X" document of particular relevance; the claimed invention cannot be considered novel or cannot be considered to involve an inventive step when the document is taken alone
- "Y" document of particular relevance; the claimed invention cannot be considered to involve an inventive step when the document is combined with one or more other such documents, such combination being obvious to a person skilled in the art.
- "&" document member of the same patent family

Date of the actual completion of the international search

24 June 1998

Date of mailing of the international search report

14/07/1998

Name and mailing address of the ISA

European Patent Office, P.B. 5818 Patentlaan 2
 NL - 2280 HV Rijswijk
 Tel. (+31-70) 340-2040, Tx. 31 651 epo nl,
 Fax: (+31-70) 340-3016

Authorized officer

Nooij, F

INTERNATIONAL SEARCH REPORT

International Application No

PCT/GB 98/00304

C.(Continuation) DOCUMENTS CONSIDERED TO BE RELEVANT		
Category	Citation of document, with indication, where appropriate, of the relevant passages	Relevant to claim No.
A	<p>K. MORGAN ET AL.: "Identification of an immunodominant B-cell epitope in bovine type II collagen and the production of antibodies to type II collagen by immunization with a synthetic peptide representing this epitope." IMMUNOLOGY, vol. 77, no. 4, December 1992, OXFORD, GB, pages 609-616, XP002069246 see abstract</p> <p style="text-align: center;">-----</p>	1-38

INTERNATIONAL SEARCH REPORT

Information on patent family members

International Application No

PCT/GB 98/00304

Patent document cited in search report	Publication date	Patent family member(s)	Publication date
WO 9414070 A	23-06-1994	AU 5558394 A	04-07-1994
WO 9418563 A	18-08-1994	US 5541295 A	30-07-1996
		AU 6174994 A	29-08-1994
		CA 2155661 A	18-08-1994
		EP 0686261 A	13-12-1995