



US00D961421S

(12) **United States Design Patent** (10) **Patent No.:** **US D961,421 S**  
**Spremann et al.** (45) **Date of Patent:** **\*\* Aug. 23, 2022**

(54) **OPTOELECTRONIC SENSOR**

(57) **CLAIM**

(71) Applicant: **SICK AG**, Waldkirch (DE)

The ornamental design for an optoelectronic sensor, as shown and described.

(72) Inventors: **Dirk Spremann**, Waldkirch (DE);  
**Davorin Jaksic**, Waldkirch (DE)

**DESCRIPTION**

(73) Assignee: **SICK AG**, Waldkirch (DE)

(\*\*) Term: **15 Years**

FIG. 1 is a perspective view of an optoelectronic sensor showing our new design;  
FIG. 2 is a front view thereof;  
FIG. 3 is a rear view thereof;  
FIG. 4 is a right side view thereof;  
FIG. 5 is a left side view thereof;  
FIG. 6 is a top view thereof;  
FIG. 7 is a bottom view thereof;

(21) Appl. No.: **29/750,810**

(22) Filed: **Sep. 16, 2020**

(30) **Foreign Application Priority Data**

Mar. 19, 2020 (EM) ..... 007762653-0001  
Mar. 19, 2020 (EM) ..... 007762653-0003  
Mar. 19, 2020 (EM) ..... 007762653-0006

FIG. 8 is a perspective view of an alternative embodiment of the optoelectronic sensor;

(51) **LOC (13) Cl.** ..... **10-04**

(52) **U.S. Cl.**  
USPC ..... **D10/70; D10/75**

FIG. 9 is a front view of the optoelectronic sensor of FIG. 8;

(58) **Field of Classification Search**  
USPC ..... D10/46, 70, 75, 78, 81, 85, 96  
(Continued)

FIG. 10 is a rear view of the optoelectronic sensor of FIG. 8;

(56) **References Cited**

**U.S. PATENT DOCUMENTS**

6,518,565 B1 \* 2/2003 Wu ..... G01D 11/245  
250/221  
6,794,639 B2 \* 9/2004 Lautenschlager .... G01D 11/245  
250/221

FIG. 11 is a right side view of the optoelectronic sensor of FIG. 8;

FIG. 12 is a left side view of the optoelectronic sensor of FIG. 8;

FIG. 13 is a top view of the optoelectronic sensor of FIG. 8;

FIG. 14 is a bottom view of the optoelectronic sensor of FIG. 8;

FIG. 15 is a perspective view of another alternative embodiment of the optoelectronic sensor;

FIG. 16 is a front view of the optoelectronic sensor of FIG. 15;

FIG. 17 is a rear view of the optoelectronic sensor of FIG. 15;

FIG. 18 is a right side view of the optoelectronic sensor of FIG. 15;

FIG. 19 is a left side view of the optoelectronic sensor of FIG. 15;

FIG. 20 is a top view of the optoelectronic sensor of FIG. 15; and,  
FIG. 21 is a bottom view of the optoelectronic sensor of FIG. 15.

(Continued)

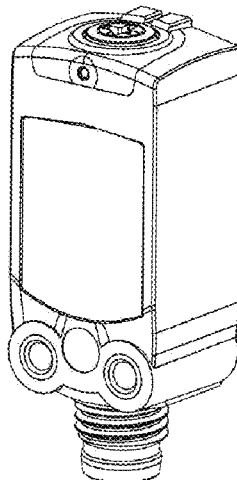
**FOREIGN PATENT DOCUMENTS**

DE 102017212259 A1 \* 1/2019  
DE 102018124845 A1 \* 4/2020

(Continued)

*Primary Examiner* — Antoine Duval Davis  
(74) *Attorney, Agent, or Firm* — Nath, Goldberg & Meyer; Jerald L. Meyer; Morgan D. Rosenberg

**1 Claim, 21 Drawing Sheets**



# US D961,421 S

Page 2

(58) **Field of Classification Search**

CPC .... G01V 8/00-26; G01V 13/00; G01V 99/00;  
G01V 2200/00; G01V 2210/00; G01S  
17/04; G01S 7/481-4818; G01D  
11/24-245

See application file for complete search history.

(56)

**References Cited**

U.S. PATENT DOCUMENTS

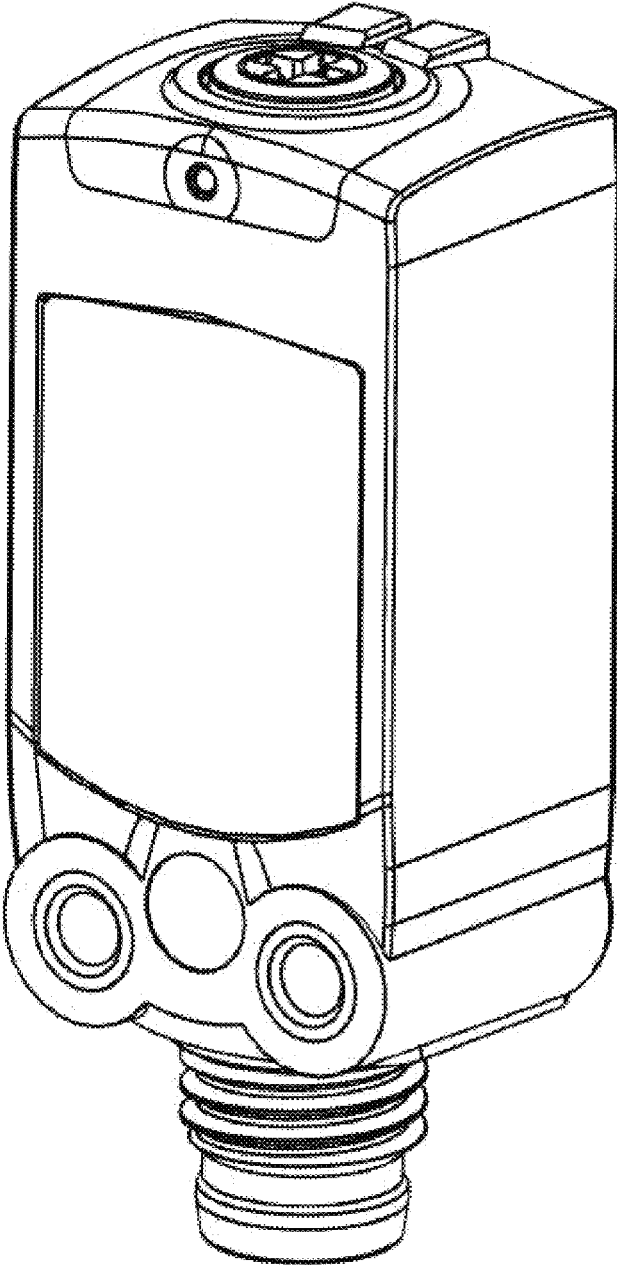
6,911,648 B2 \* 6/2005 Wu ..... G01D 11/245  
250/221  
7,009,285 B2 \* 3/2006 Su ..... H01L 33/60  
257/E33.059  
7,102,078 B2 \* 9/2006 Weber ..... G01D 11/245  
174/64  
D531,525 S \* 11/2006 Dold ..... D10/46  
D612,751 S \* 3/2010 Bach ..... G01D 11/245  
D10/46  
D617,214 S \* 6/2010 Siegler ..... G01D 11/245  
D10/46

D654,383 S \* 2/2012 Pfrengle ..... G01D 11/245  
D10/46  
D736,657 S \* 8/2015 Detering ..... G01D 11/245  
D10/75  
D737,695 S \* 9/2015 Angenendt ..... G01D 11/245  
D10/75  
10,030,999 B2 \* 7/2018 Fabbri ..... G01S 17/04  
D912,553 S \* 3/2021 Thurnherr ..... D10/75  
D912,633 S \* 3/2021 Mizusaki ..... D10/70  
D916,607 S \* 4/2021 Takahashi ..... D10/70  
D916,608 S \* 4/2021 Takahashi ..... D10/70  
D926,058 S \* 7/2021 Shah ..... D10/75  
2009/0095074 A1 \* 4/2009 Vinshtok ..... G01D 11/245  
73/431

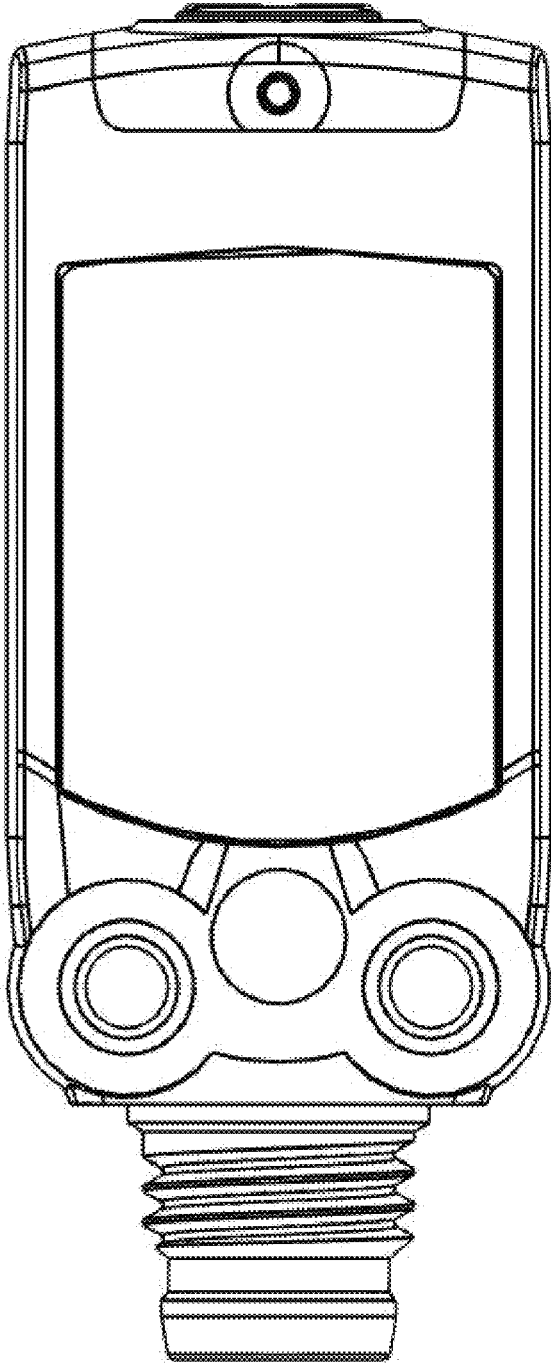
FOREIGN PATENT DOCUMENTS

EP 2664900 A1 \* 11/2013 ..... G01D 11/245  
EP 2767807 A2 \* 8/2014 ..... G01D 11/245  
EP 3163258 B1 \* 10/2018 ..... G01D 11/24  
WO WO-2012110837 A1 \* 8/2012 ..... G01S 17/026

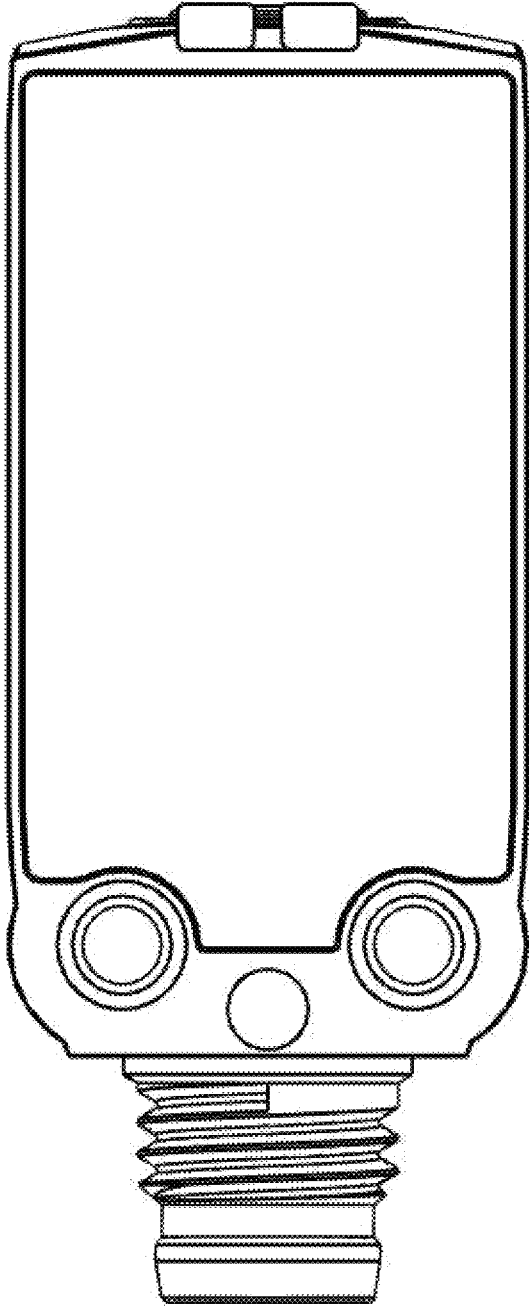
\* cited by examiner



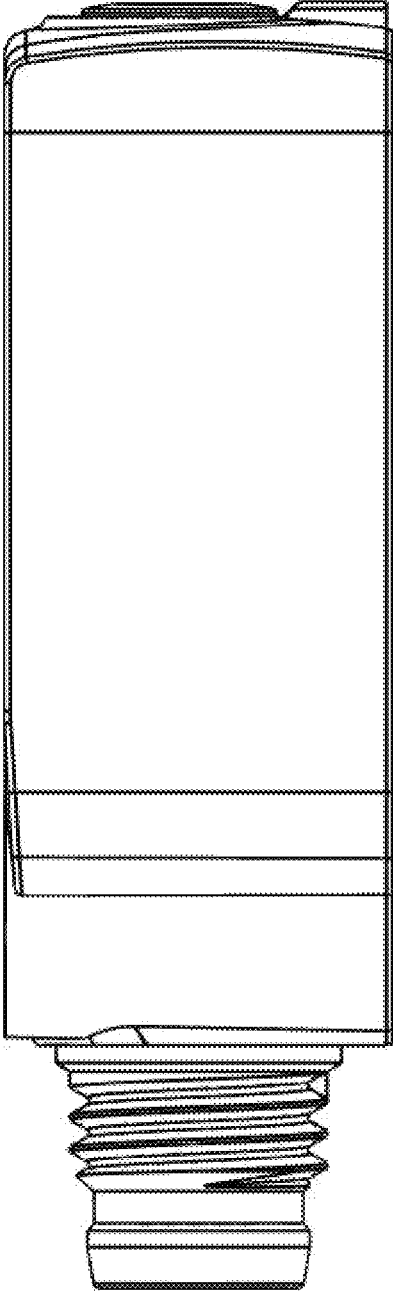
*Fig. 1*



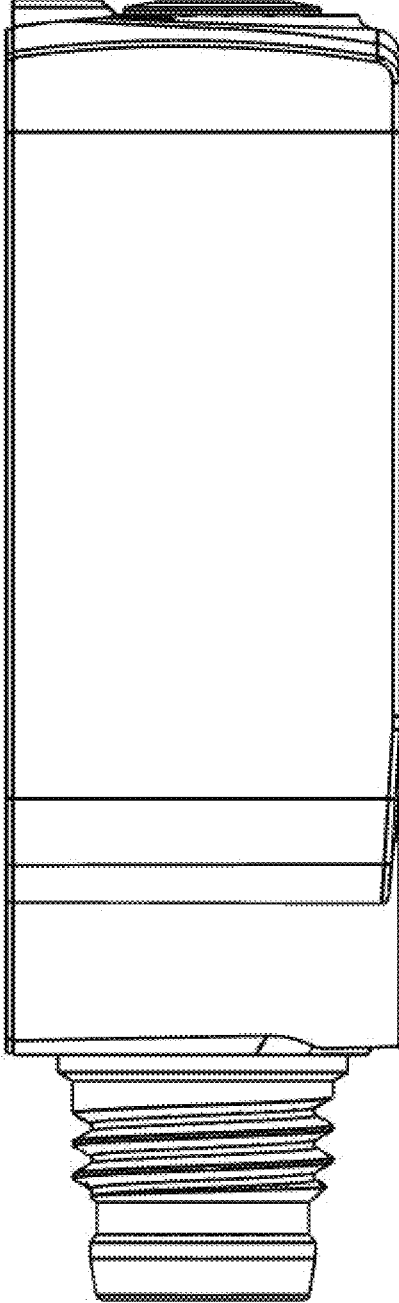
*Fig. 2*



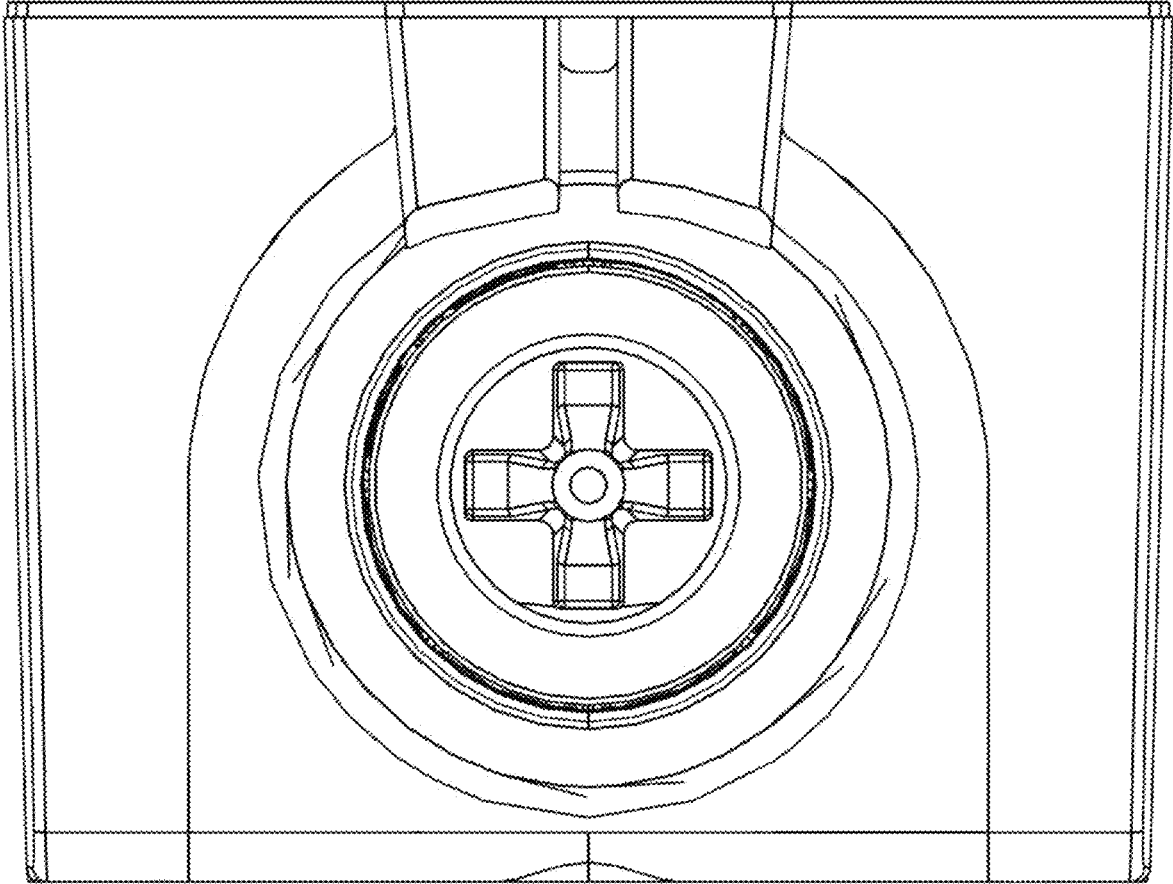
*Fig. 3*



*Fig. 4*

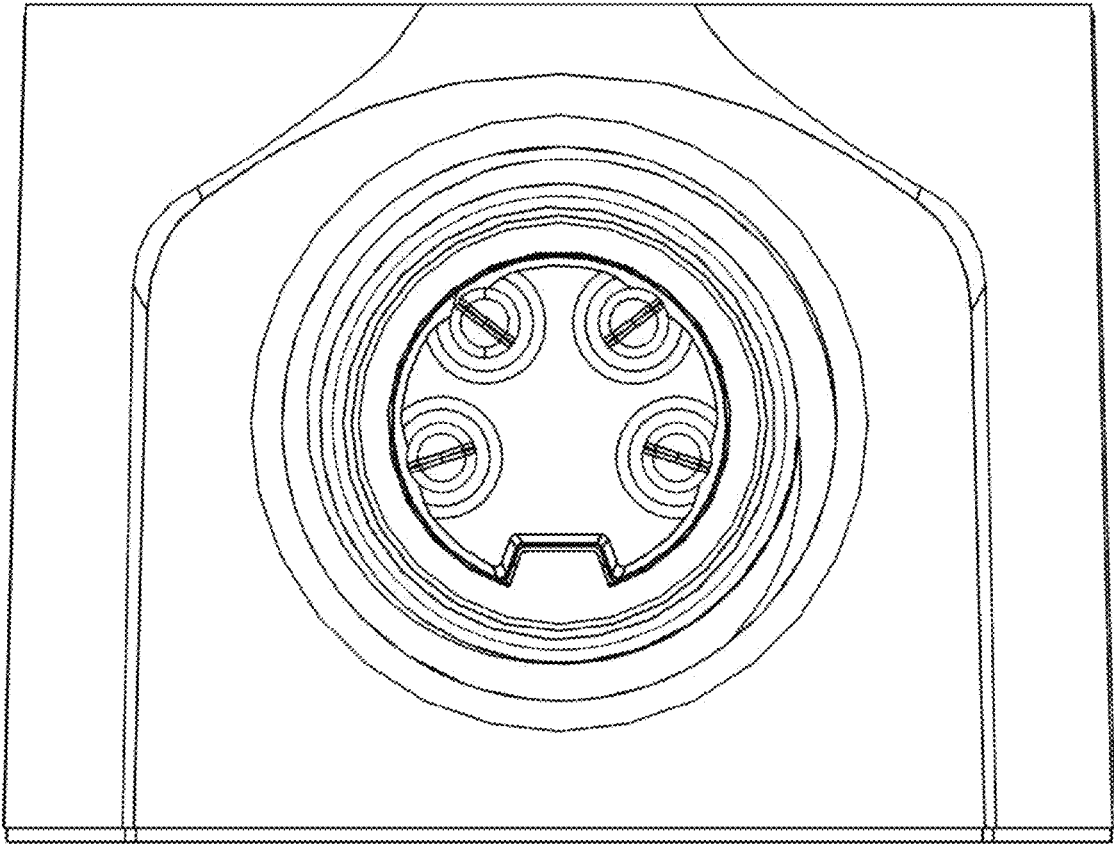


*Fig. 5*

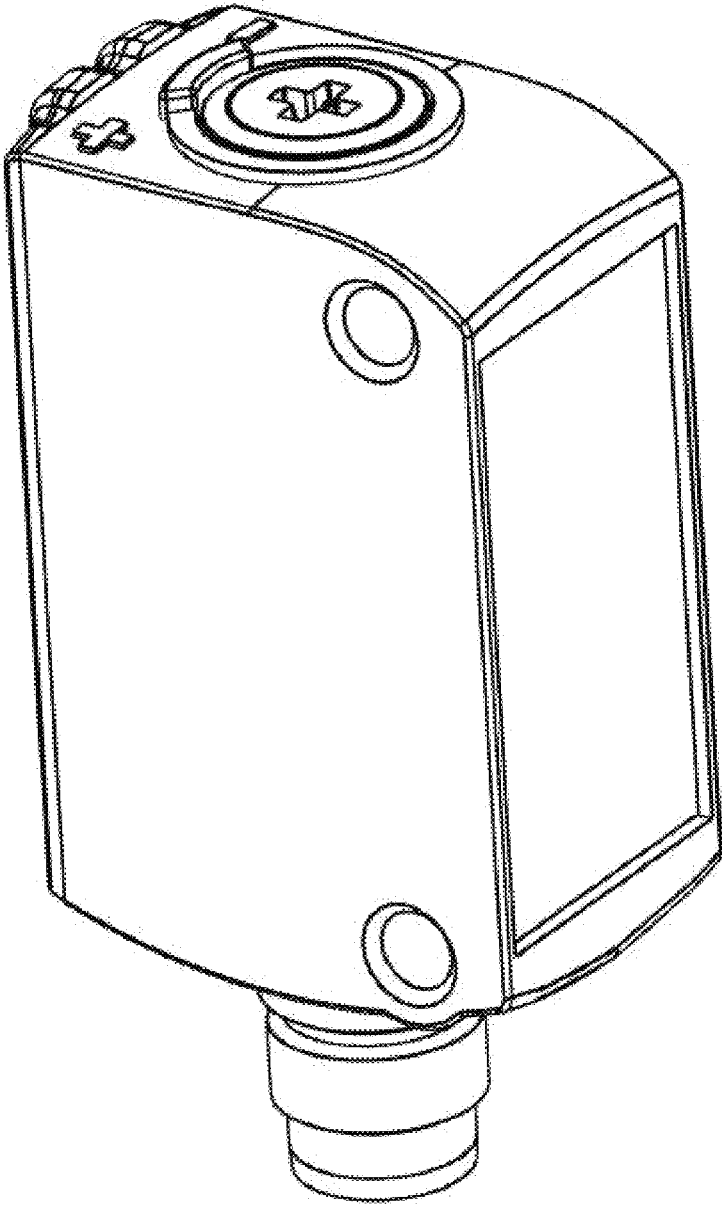


**Fig. 6**

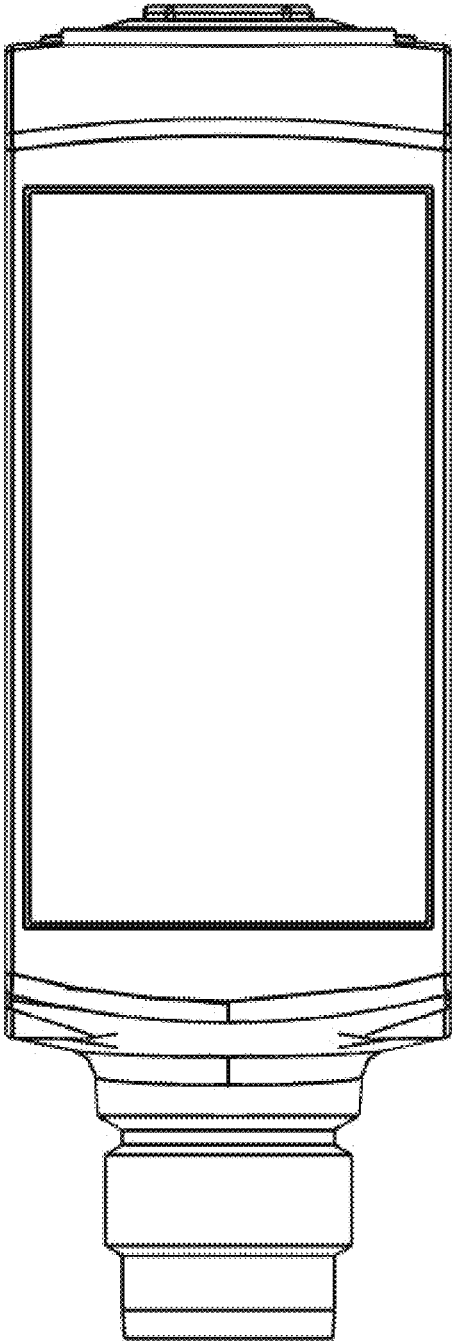




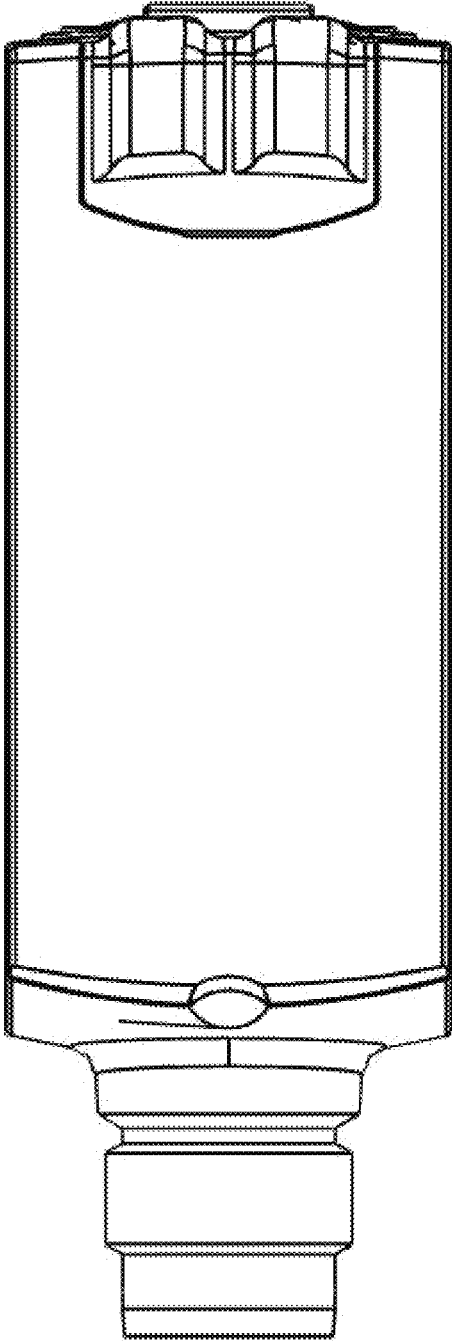
**Fig. 7**



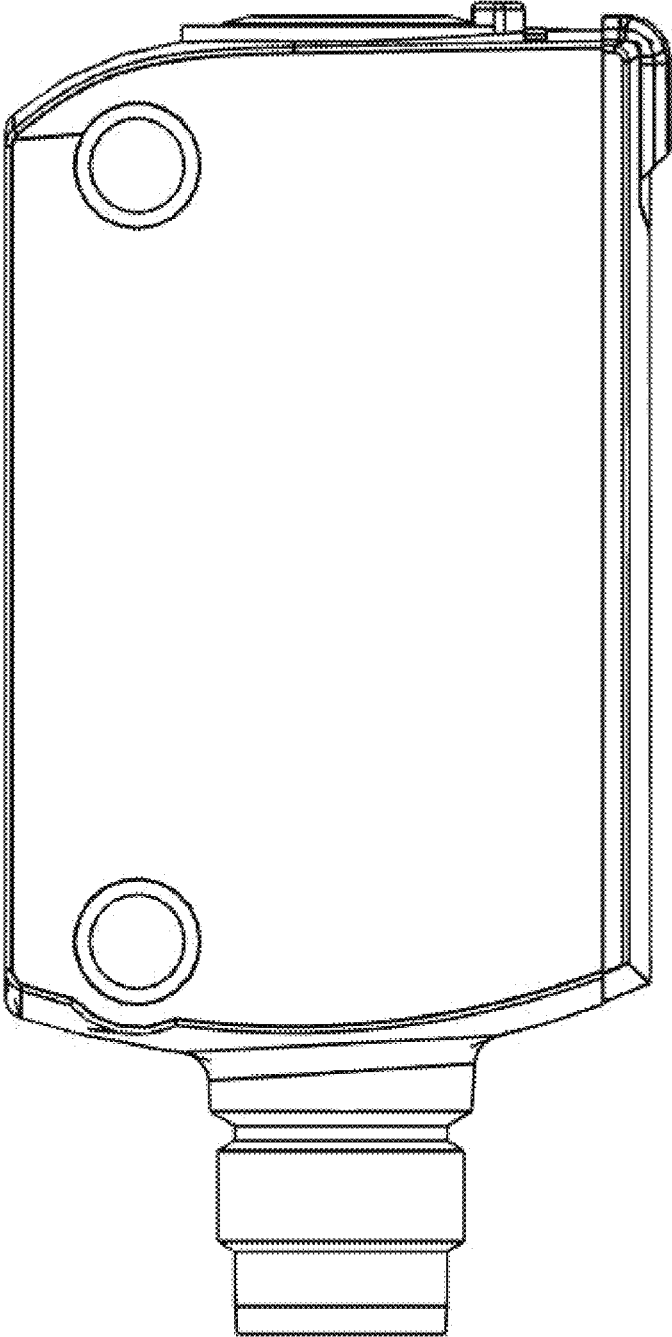
**Fig. 8**



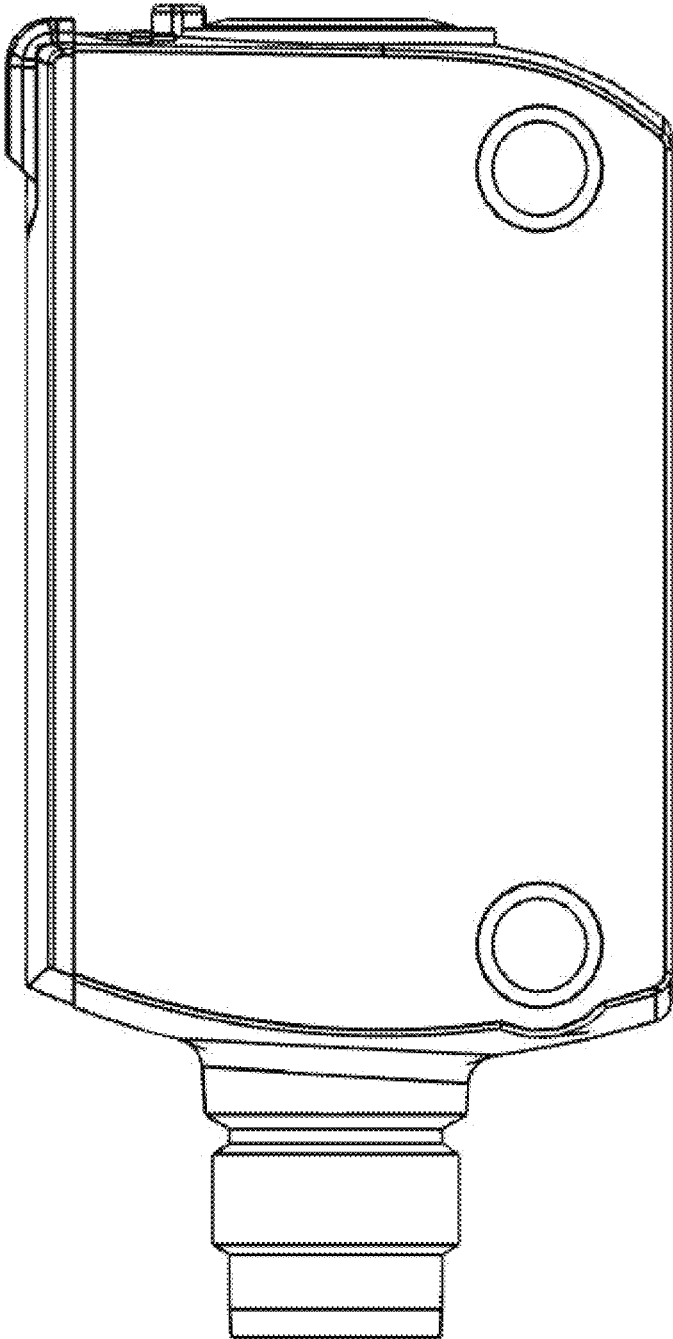
*Fig. 9*



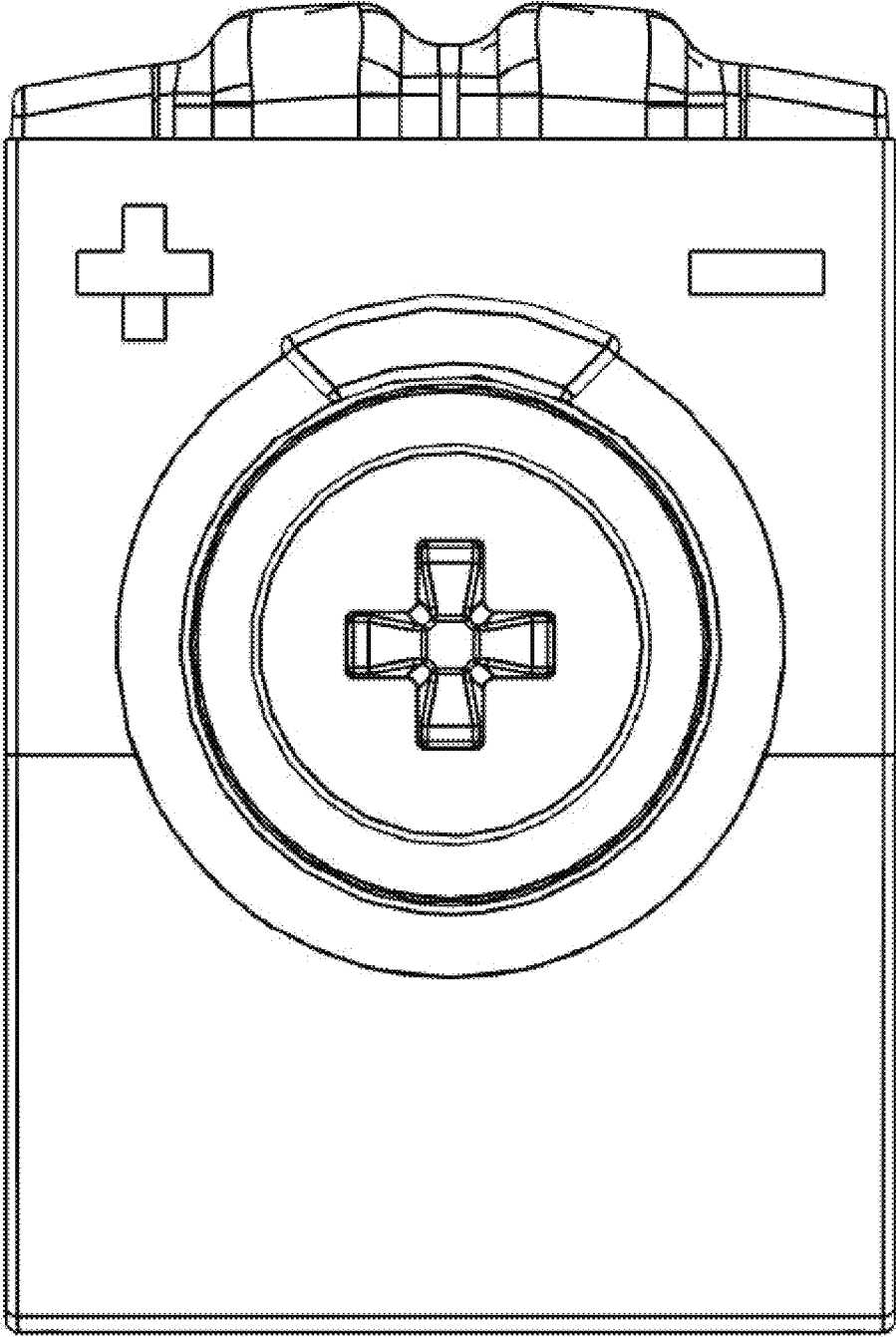
*Fig. 10*



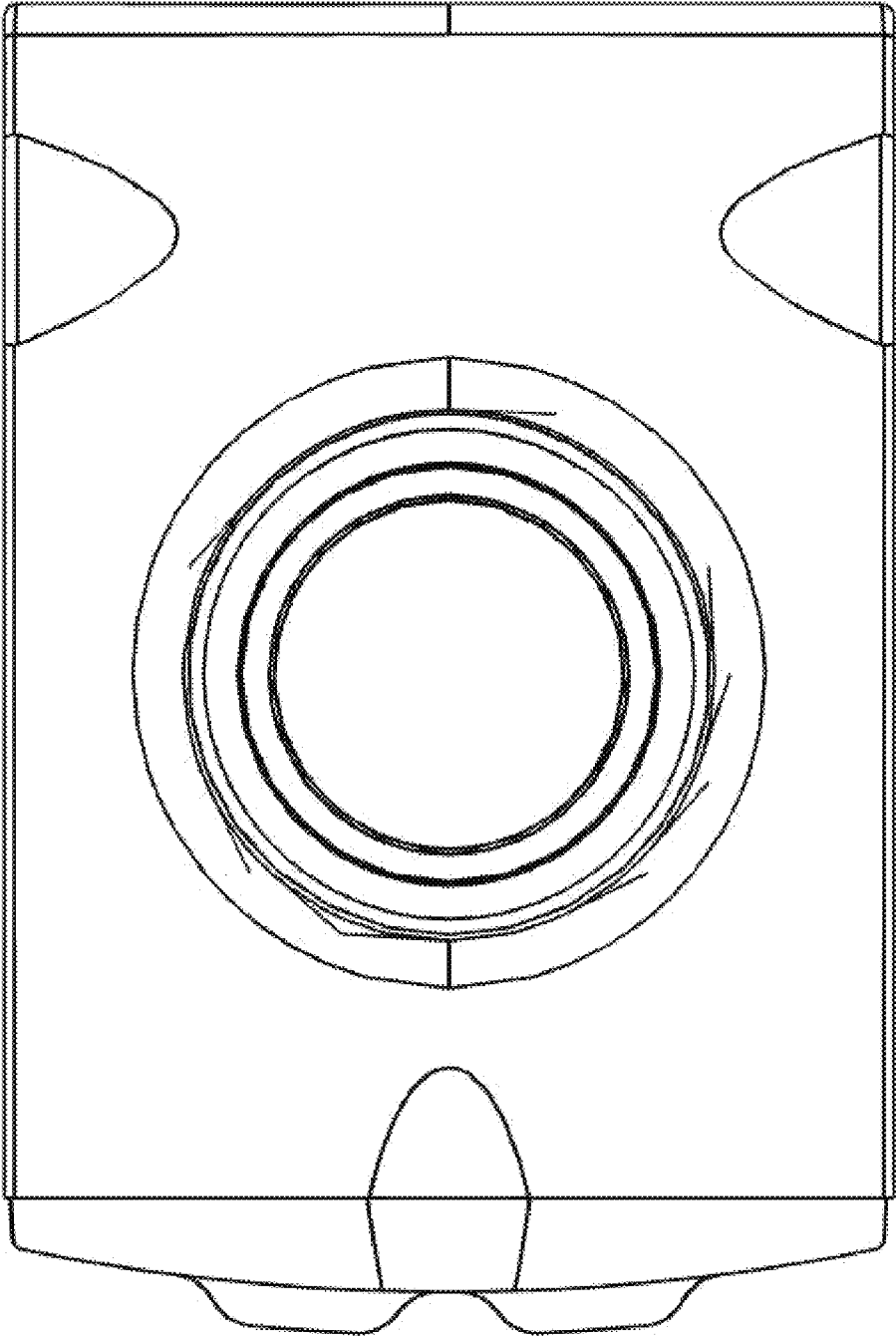
**Fig. 11**



*Fig. 12*

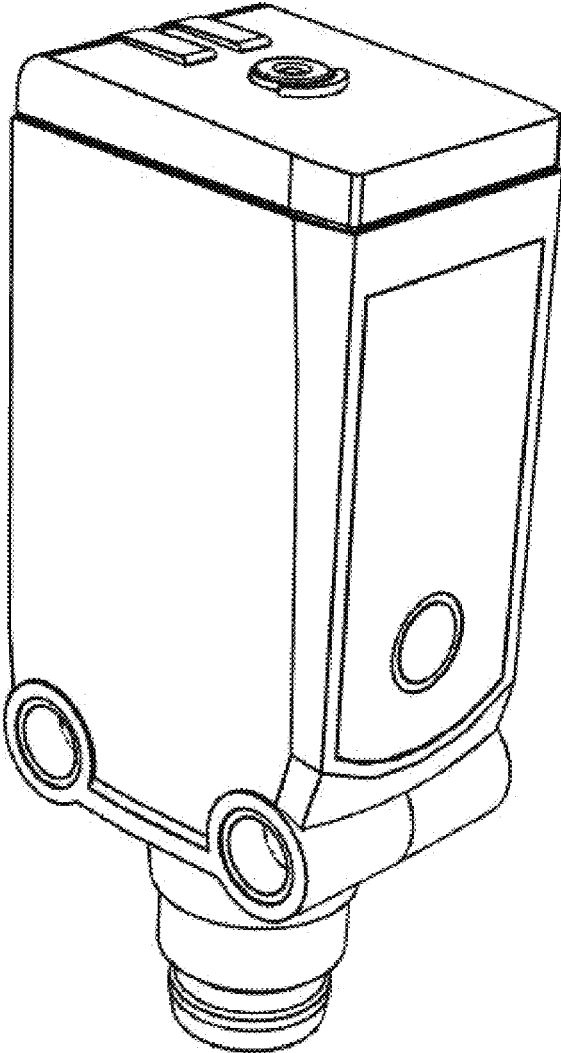


*Fig. 13*

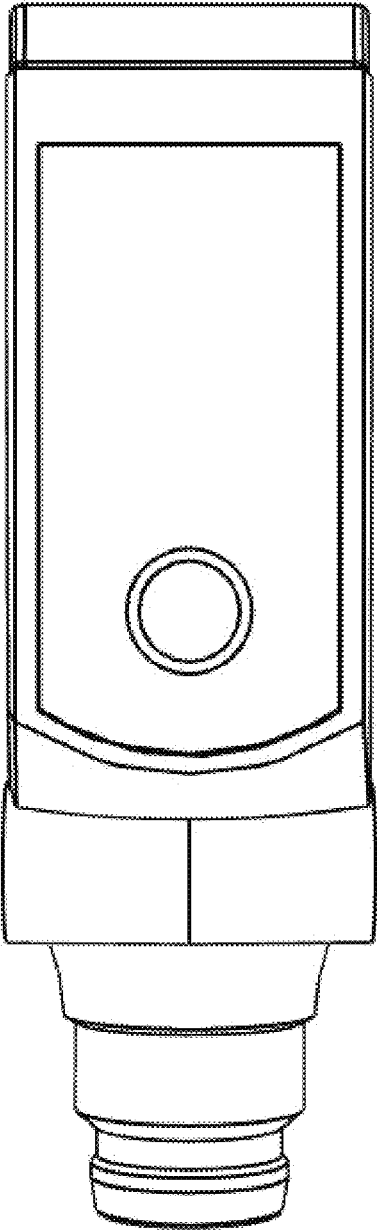


*Fig. 14*

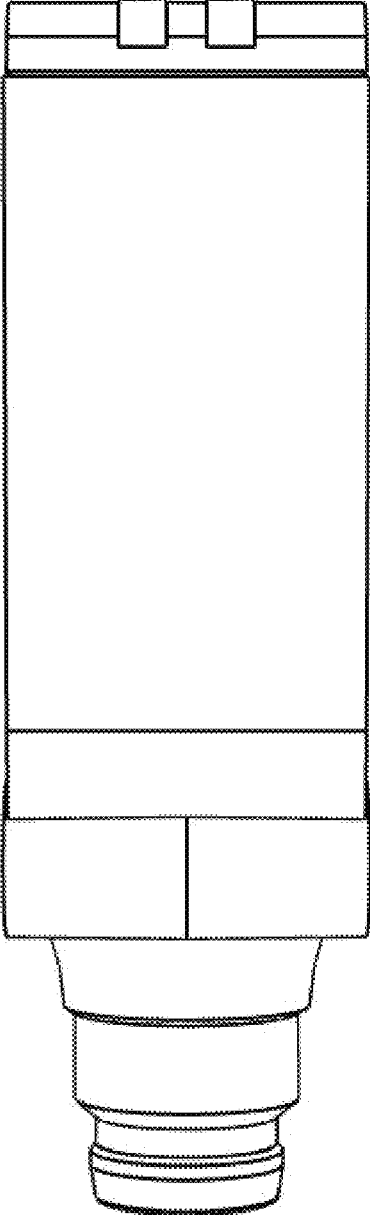




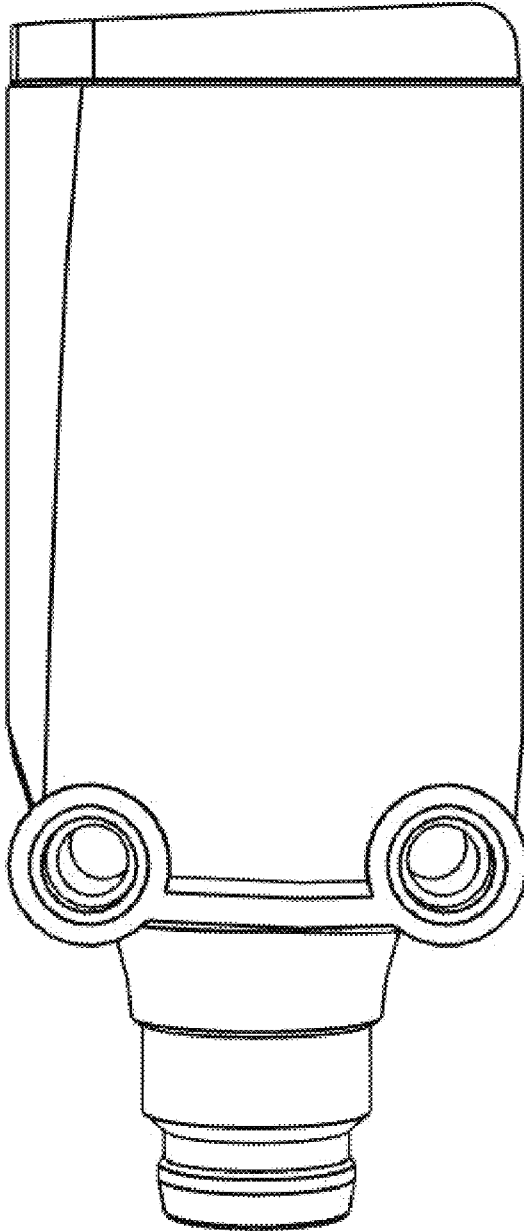
*Fig. 15*



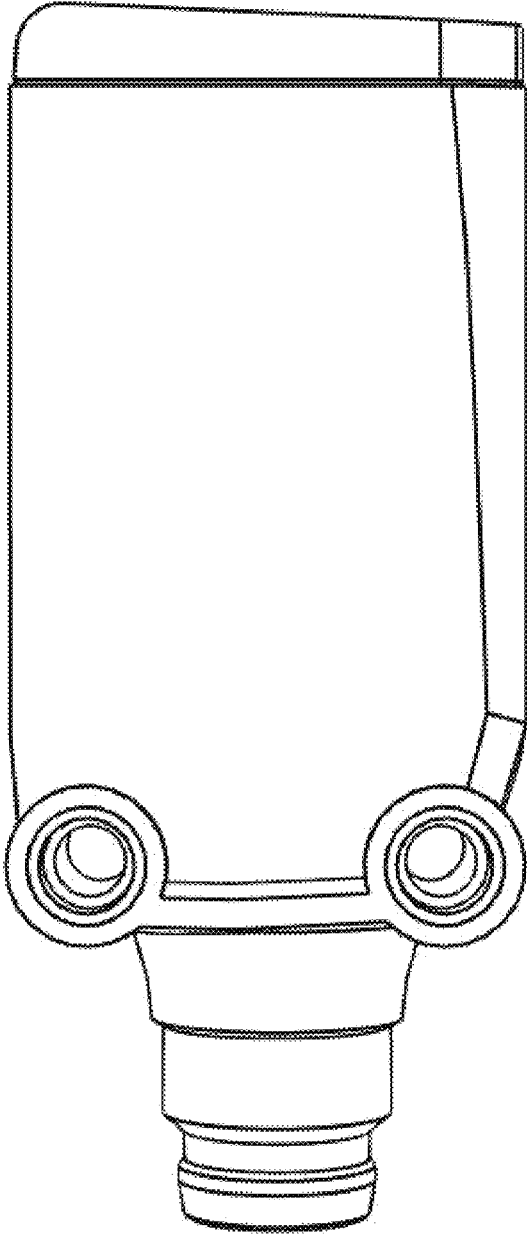
*Fig. 16*



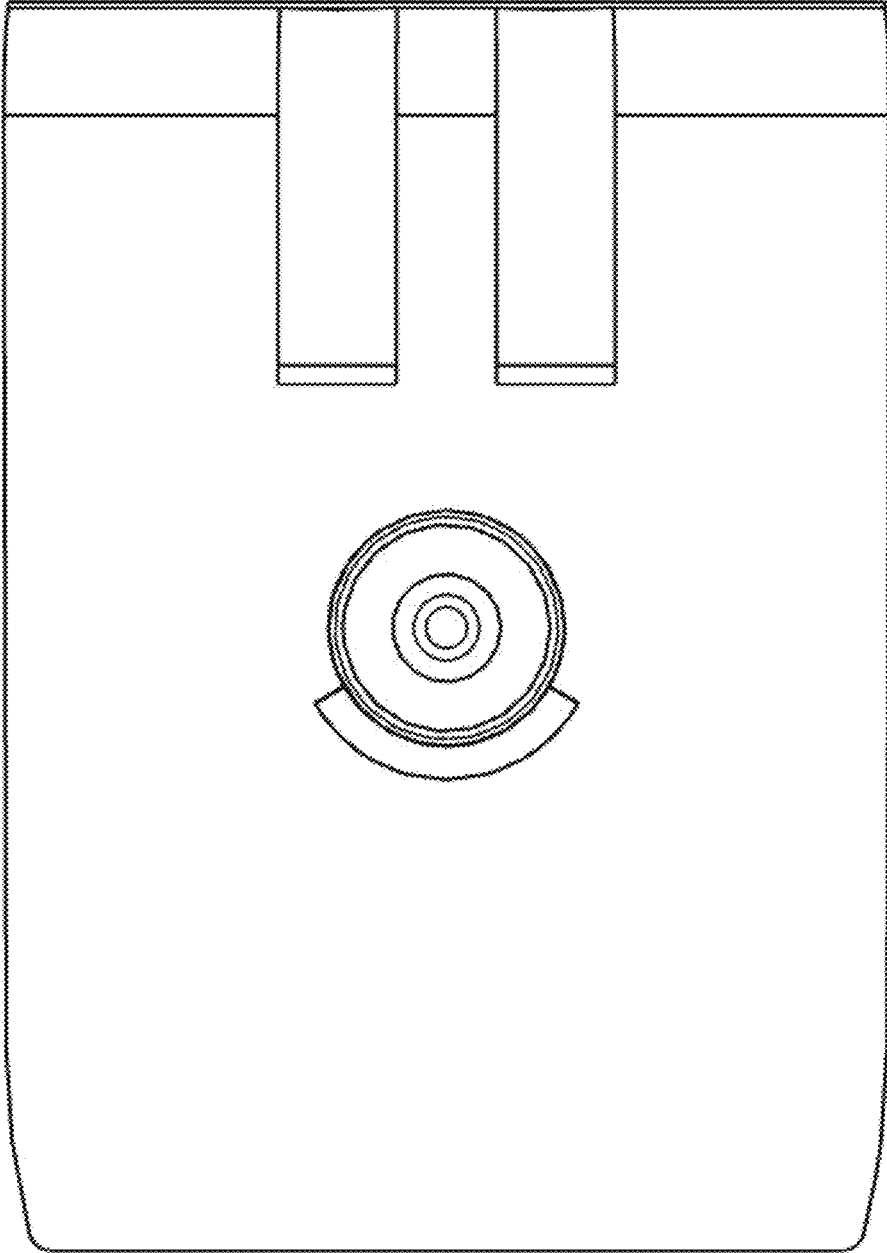
*Fig. 17*



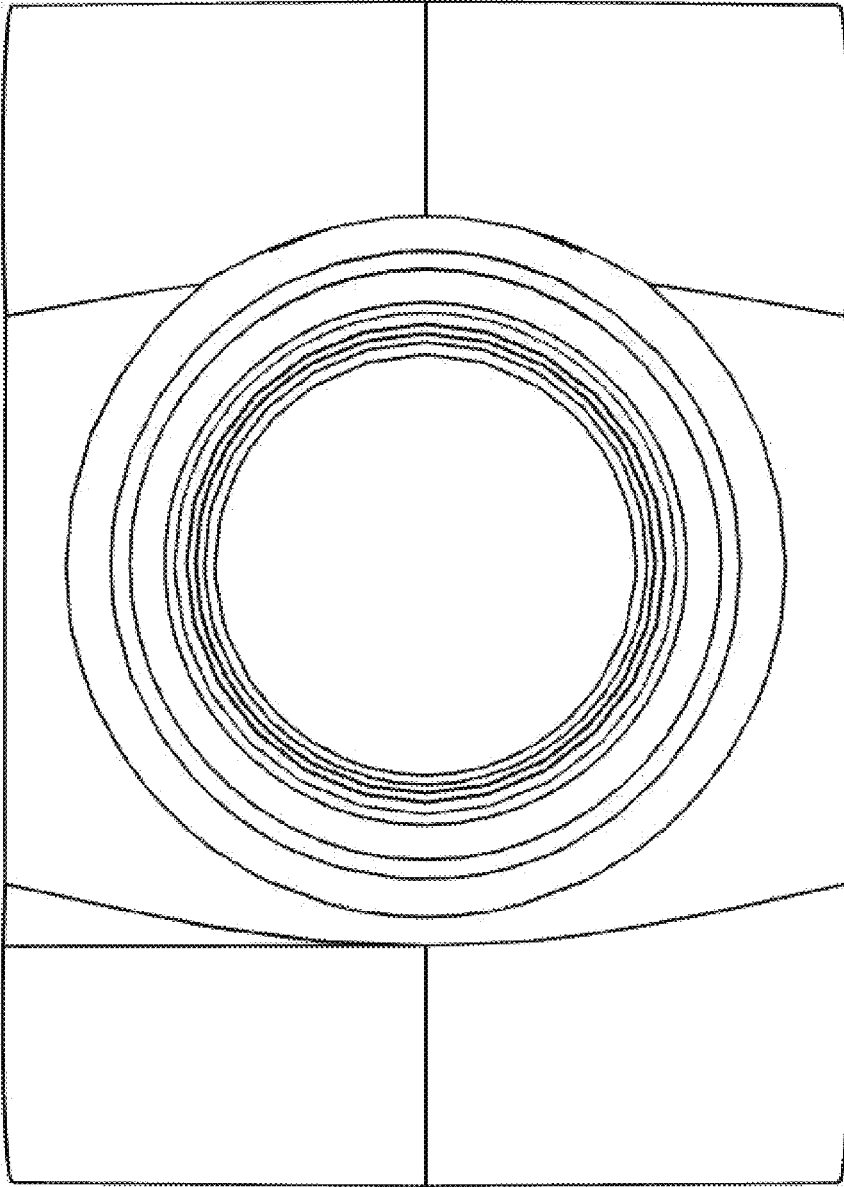
*Fig. 18*



*Fig. 19*



**Fig. 20**



**Fig. 21**