

March 4, 1958

A. AVDEENKO

2,825,773

MULTIPLE-CIRCUIT SELECTOR SWITCH DEVICE

Filed Nov. 8, 1954

3 Sheets-Sheet 1

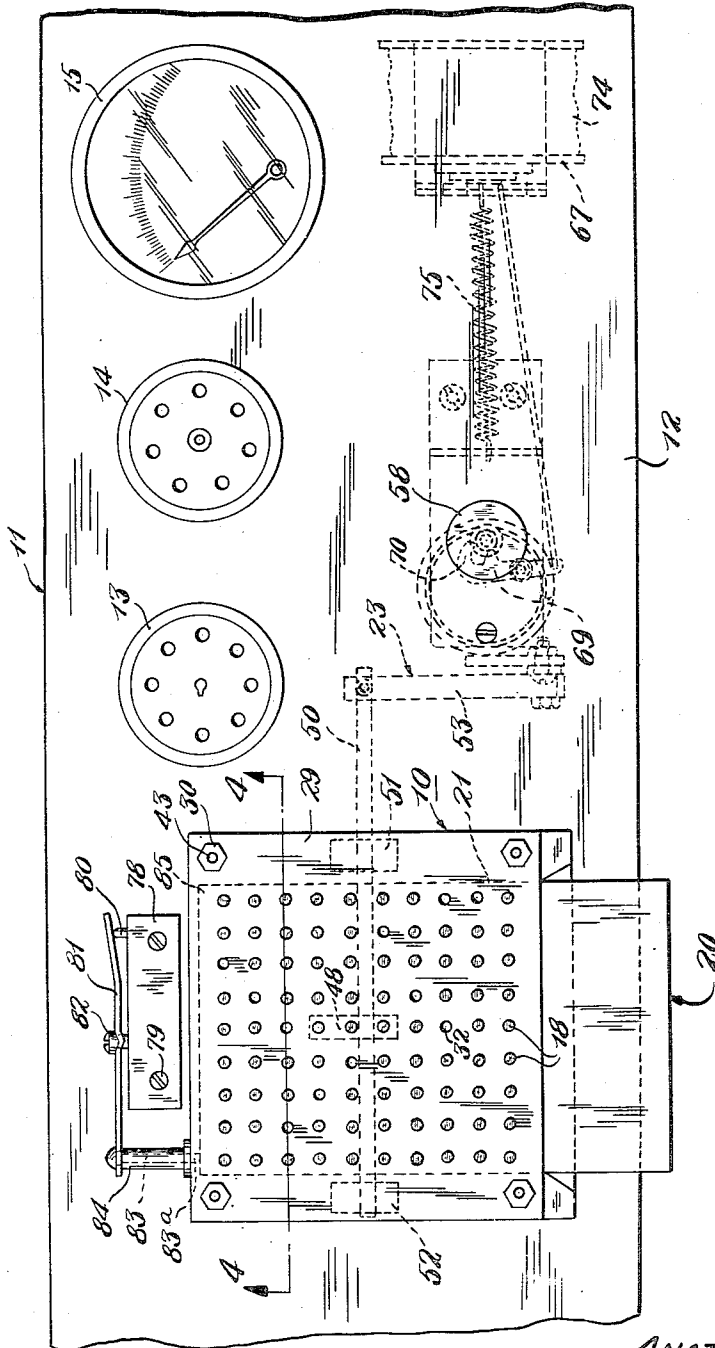

FIG. 1

INVENTOR.

ANATOL AVDEENKO

BY Hudson, Boughton,

Williams, David & Hoffmann
ATTORNEYS

March 4, 1958

A. AVDEENKO

2,825,773

MULTIPLE-CIRCUIT SELECTOR SWITCH DEVICE

Filed Nov. 8, 1954

3 Sheets-Sheet 2

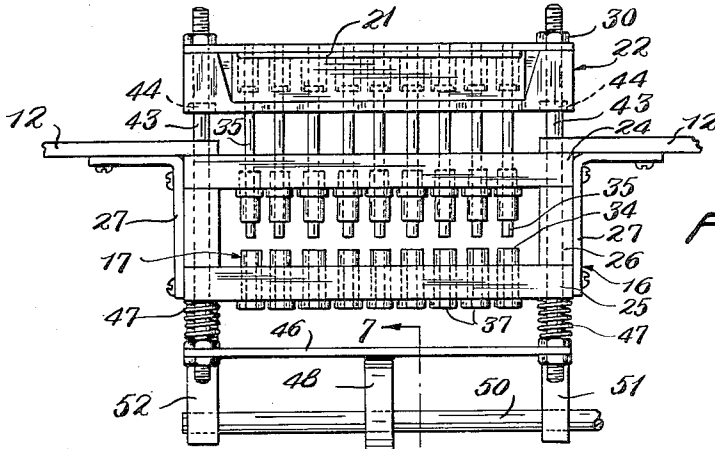

FIG. 2

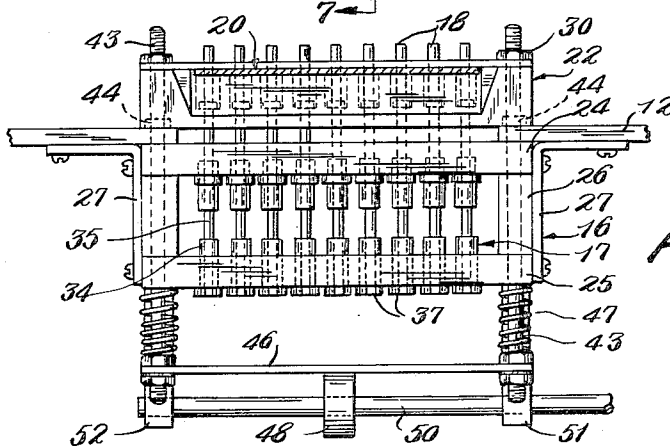

FIG. 3

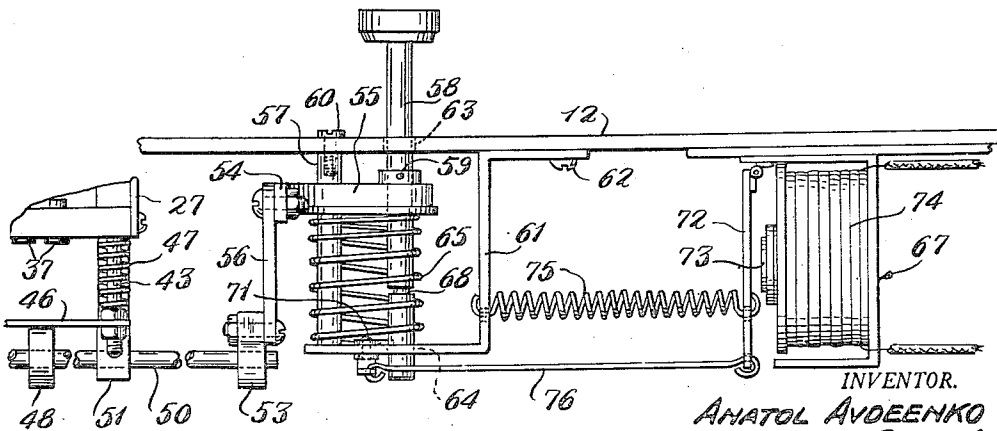

FIG. 5

INVENTOR.

ANATOL AVDEENKO

BY Hudson, Baughton,

Williams, David & Hoffmann

ATTORNEYS

March 4, 1958

A. AVDEENKO

2,825,773

MULTIPLE-CIRCUIT SELECTOR SWITCH DEVICE

Filed Nov. 8, 1954

3 Sheets-Sheet 3

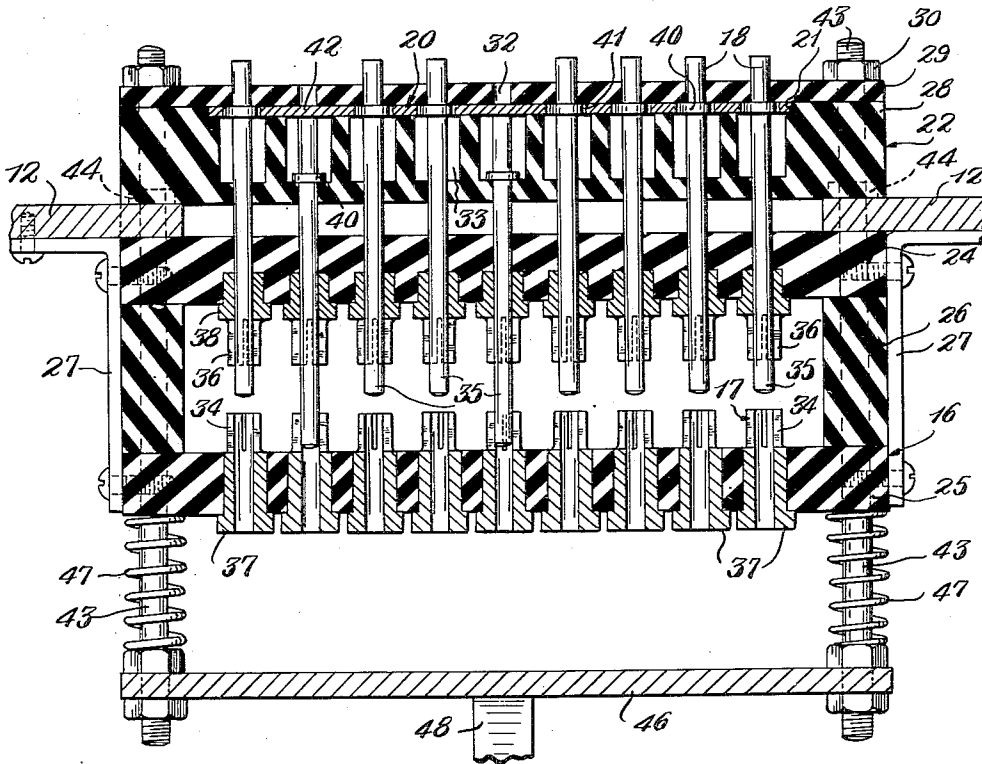

FIG. 4

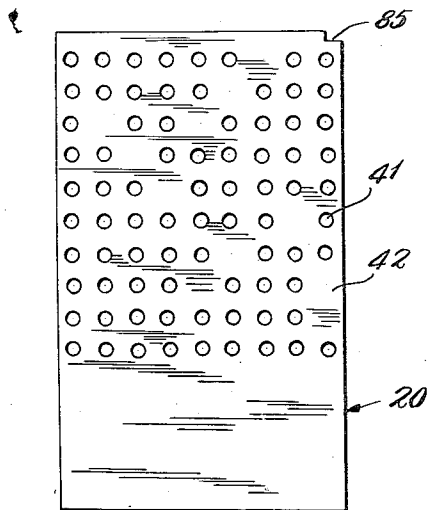

FIG. 6

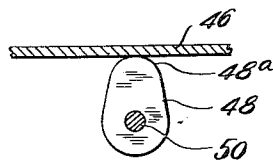

FIG. 7

INVENTOR.

ANATOL AVDEENKO

BY Hudson, Daughton,

Williams, David & Hoffmann

ATTORNEYS

1

2,825,773

MULTIPLE-CIRCUIT SELECTOR SWITCH DEVICE 5

Anatol Avdeenko, Rochester, N. Y., assignor to Cleveland Patents, Incorporated, Cleveland, Ohio, a corporation of Ohio

Application November 8, 1954, Serial No. 467,429 10

15 Claims. (Cl. 290-46)

This invention relates to multiple-circuit selector switch devices, and, as its principal object, aims to provide a novel selector switch device of a simple and practical construction and in which a control card removably inserted into a guideway and having a pattern of punched openings and imperforate areas automatically selects the individual switches to be actuated.

This novel selector switch device can be applied to various kinds of service, but is especially useful in tube-testers for testing electron tubes and is hereinafter described as applied to that use but without any intention of limiting the invention solely to that specific application.

Another object is to provide a selector switch device in which the individual switches have stems engageable by the imperforate areas of the control card for selecting and actuating the desired switches, and in which a movable actuating means for causing the card-to-stem engagement includes an electrically energizable means controlled by a control switch.

A further object is to provide such a card-controlled switch device in which the control card is insertable in a guideway and in which the control switch is actuatable in response to movement of the card in the guideway, preferably by a direct engagement of the card with the control switch upon substantially a full movement of the card into the guideway.

Still another object is to provide a card-controlled selector switch device of the character above indicated in which a spring pressure responsive actuating means is employed for causing the engagement of the switch stems by the imperforate areas of the control card, and in which such spring pressure responsive means becomes effective upon the release of a locking means therefor.

Yet another object is to provide a card-controlled selector switch device of the character mentioned above in which the guideway for the control card is in a movable carrier, and in which the actuating means for the carrier includes a movable cam and an electromagnetic device whose energizing circuit is controlled by a control switch.

Additionally, this invention provides a card-controlled selector switch device of the kind referred to above in which a manual means is operable to load the spring means, and in which a switch-controlled electromagnetic device operates to release the locking means for rendering the spring means effective.

Other objects and advantages of the invention will be apparent in the following detailed description and in the accompanying sheets of drawings forming a part hereof and in which:

Fig. 1 is a partial plan view of a selector switch device embodying the present invention and which shows the switch device being used in a tube-tester and as having the control card in its fully inserted position;

Fig. 2 is a partial front elevation of the selector switch device showing the same with the control card removed and with the individual switches in open position;

2

Fig. 3 is a partial front elevation similar to Fig. 2, but showing the control card inserted and with certain of the individual switches actuated to their closed position;

Fig. 4 is a partial transverse vertical section taken on section line 4-4 of Fig. 1 and showing the individual switches on a larger scale;

Fig. 5 is another partial front elevation further illustrating the actuating and control means of the switch device;

Fig. 6 is a plan view showing one of the control cards in detached relation; and

Fig. 7 is a fragmentary elevational view further illustrating a cam member of the actuating and control means.

In the accompanying drawings, the multiple-circuit card-controlled selector switch device 10 is shown, by way of example, as being embodied in a tube-tester 11 for testing electron tubes of different types. The switch device 10 is mounted on a support plate 12 and, when this switch device is embodied in such a tube-tester, the support plate forms the cover of the housing of the tube-tester. As here shown, the support plate 12 also forms amount for a plurality of tube sockets 13 and 14 adapted to receive electron tubes of different types as well as a mount for an indicator or meter 15 for indicating the quality or other characteristics of the tubes being tested.

The selector switch device 10 comprises, in general, a support structure 16 carrying a bank of individual switches 17 having projecting actuating stems 18, and a control card 20 removably inserted in a guideway 21 of a card holder or carrier 22 for cooperation with the stems 18. The switch device 10 also comprises actuating and control means 23 for the carrier 22 for causing movement of the control card 20 by which the stems 18 of the desired switches 17 are selected and actuated.

The support structure 16 comprises a pair of upper and lower plate members 24 and 25 made of suitable insulating material and held in spaced relation by spacer members 26 disposed therebetween. The support structure 16 is attached to the cover 12 by suitable connecting means such as the brackets 27.

The carrier 22 comprises a pair of body and cover members 28 and 29 made of suitable insulating material and secured together as by means of clamping nuts 30 so as to define therebetween the above-mentioned guideway 21. The cover member 29 has a plurality of longitudinally and transversely spaced openings 32 therein, and the body member 22 has a corresponding number of similarly spaced recesses 33 therein which are located below and in coaxial alignment with the openings 32.

The individual switches 17 each comprise a pair of cooperating stationary and movable switch contacts 34 and 35 of which the movable contact 35 is here shown as being a plunger extending through and slidable in a hollow terminal member 36. The stationary contact 34, as here shown, is in the form of a sleeve having an expandible upper end into which the contact plunger 35 is movable for the closed position of the switch. Electrical connection with the contact plunger 35 is made through the terminal member 36, which also forms a guide bushing for the contact plunger for aligning the latter with the hollow stationary contact 34.

The hollow stationary contacts 34 of the individual switches 17 are located in longitudinal and transverse rows and are supported on the insulating plate member 25 by being molded in, or otherwise secured to, this plate member. In this instance, the stationary contacts 34 are sleeve-like members extending through the plate member 25, with heads 37 on the underside of such plate member and to which electrical conductors can be soldered or otherwise suitably attached. The terminal members 36

are molded in, or otherwise secured to, the insulating plate member 24 and have collar portions 38 to which electrical conductors can be soldered or otherwise suitably attached.

Although the electrical conductors defining the circuits controlled by the individual switches 17 are not here shown, it will be understood that such conductors connect the stationary and movable contacts 34 and 35 of these switches with the various appropriate terminals of the tube sockets 13 and 14 and with the indicator 15, as well as with a power source and with various other components which may be embodied in the tube-tester.

The above-mentioned actuating stems 18 of the individual switches 17 are here shown as being extensions of the contact plungers 35 and as being of a length to extend across the guideway 21 in a direction substantially normal to the plane of the guideway. The stems 18 are provided adjacent the upper end thereof with a shoulder means comprising fixed collars 40 which are movable in the recesses 33 of the carrier 22.

The control card 20 comprises a relatively stiff or semi-rigid sheet-like member made of paper, cardboard, plastic, or any other suitable insulating material. As shown in Fig. 6, this control card is of a generally rectangular shape and has longitudinally and transversely extending rows of openings 41 therein with imperforate areas 42 located between certain of these openings. The openings 41, and the imperforate areas 42 where they occur, are located on the card in such longitudinally and transversely spaced relation that the openings and areas will be in alignment with the stems 18 when the control card is fully inserted into the guideway 21.

With respect to the control card 20, it should be explained further that the imperforate areas 42 are provided on the card in such number and location as to correspond with the individual switches 17 which are desired to be actuated for a particular purpose. Thus, when the selector switch device 10 is embodied in the tube-tester 11, a set of the control card 20 would be furnished in which each card would represent a different type of electron tube. The different cards of the set would have different patterns for the imperforate areas 42 to correspond with the different groups of individual switches 17 desired to be actuated for the different type of tubes being tested.

The carrier 22 is movable toward and away from the support plate 12 as by means of thrust rods 43 which extend through, and are slidable in, the support structure 16. The carrier 22 is secured against shouldered portions 44 of the thrust rods 43 by means of the nuts 45. The lower ends of the thrust rods 43 extend in depending relation to the support structure 16 and carry a thrust plate 46. Compression springs 47 are disposed around the thrust rods 43 and are located between the thrust plate 46 and the lower plate member 25 of the support structure 16.

The springs 47 constantly apply a downwardly acting force to the thrust plate 46, such that the thrust rods 43 apply a downward pulling force to the carrier 22 tending to move the latter to its lower position in engagement with the support plate 12, as shown in Figs. 3 and 4, and which corresponds with the closed-switch position for the individual switches 17 which were selected for actuation. The carrier 22 is movable to its upper or open-switch position shown in Fig. 2, by an upward movement transmitted to the thrust rods 43 by the thrust plate 46 and which upward movement also deflects the springs 47 to the loaded or compressed condition shown in this Fig. 2. The upward actuating movement of the thrust plate 46 is here shown as being produced by a cam 48 forming a part of the hereinafter-described actuating and control means 23.

The proper control card 20 is selected and inserted into the guideway 21 while the carrier 22 is in its upper position shown in Fig. 2. When the carrier 22 is moved downwardly by the actuating and control mechanism 23, the imperforate areas 42 of the selected control card will engage the upper ends of the stems 18 and will cause

a downward actuation of all of the stems which have been engaged by such imperforate areas.

The stems 18 which are located opposite the control card openings 41 will be substantially unaffected by the movement of the carriage 22 inasmuch as the upper ends of these stems will pass freely through the openings 41 of the card. The downward movement of the stems 18 which have been thus selected and actuated by the imperforate card areas 42, will cause the movable switch contacts 35 to engage in the hollow stationary contacts 34 to close the individual switches 17 corresponding with such imperforate areas of the control card.

During the upward movement of the carrier 22, the collars 40 of those stems which were previously moved downwardly by the imperforate areas 42, will be engaged by the transverse lower end wall of the recesses 33 by which a lifting force will be applied to those particular stems for retracting the switch plungers 35 from the stationary hollow contacts 34 to cause opening of the previously closed individual switches 17. Those stems which were not moved downwardly by the carriage 22 by reason of their extending through the card openings 41, will be substantially unaffected by the upward movement of the carriage inasmuch as the card openings will again permit a free movement of the card relative to these particular stems.

The use of the compression springs 47 for causing the downward switch-closing or working stroke of the carriage 22 represents a very satisfactory way of producing this working stroke of the carriage inasmuch as the force of these springs will provide for a very rapid movement of the carriage. The use of these compression springs 47 is also desirable from the point of view that if some obstruction should accidentally come between the movable switch plungers 35 and the stationary switch contacts 34 at the time of actuation of the device, the springs would permit the downward movement of the carriage 22 to be stopped by the obstruction without causing breakage of the device, such as would occur if the carriage were being actuated by a positive force-applying means connected thereto.

The actuating and control means 23 will be described next and is here shown with the cam 48 carried by a rockshaft 50 and engaging the underside of the thrust plate 46. The rockshaft 50 is suitably journaled in bearings carried by posts or brackets 51 and 52 extending in depending relation from the support structure 16. The rockshaft 50 is provided at the outer end thereof with a lever arm or crank 53 which is connected with an arm projection 54 of a reciprocably removable head 55 by means of a connecting link 56. The head 55 is slidably guided on a guide post 57 and is adapted to be moved downwardly by a manually operable plunger 58 to which the head is connected as by means of a setscrew or pin 59.

The guide post 57 has its upper end secured to the support cover 12 as by means of a screw 60 and its lower end riveted, or otherwise secured, to a bracket 61 which is connected to the underside of the support cover by one or more screws 62. The manually operable plunger 58 extends freely through an opening 63 of the support cover 12 and its lower end slidably extends through a guide opening 64 of the bracket 61. A compression spring 65 is disposed between the head 55 and the lower portion of the bracket 61 and surrounds the plunger 58 and the guide post 57.

The head 55 is movable downwardly by the manual plunger 58 in opposition to the compression spring 65 to thereby rock the shaft 50 by movement transmitted through the connecting link 56. Rocking of the shaft 50 causes a rotary movement of the cam 48 by which the lift portion 48^a of the cam is made effective on the thrust plate 46 to lift the latter and thereby actuate the carriage 22 through the thrust rods 43 to the open-switch position, as well as to load the springs 47.

5

A holding or locking means is effective on the plunger 58 for retaining the head 55 in its lowermost position corresponding with the raised position of the carrier 22 and is adapted to be released by energization of an electromagnet 67. This locking means comprises an annular groove 68 in the plunger 58 and a latch lever 69 having a forked end 70 engageable in the groove 68. The latch lever 69 is mounted on the lower portion of bracket 61 by a pivot pin 71 about which the latch lever is swingable for engaging the latter in, and disengaging the same from, the groove 68.

The electromagnet 67 is suitably mounted on the support cover 12 and has an armature 72 which is movable toward the core 73 in response to energization of the magnet coil 74. A tension spring 75 extending between the bracket 61 and the armature 72 acts on the armature to move the same in a direction away from the core 73 and also acts to impart locking movement to the latch lever 69 through a connecting link 76. With the arrangement just described, it will be seen that upon downward manual movement of the plunger 58 to actuate the carrier 22 to its upper position and load the springs 47 and 65, the latch lever 69 will be automatically engaged in the groove 68 by the action of the spring 75, such that the holding means will cause the springs 47 and 65 to be maintained in their loaded condition and will cause the carriage 22 to be held in its upper position shown in Fig. 2 in readiness to receive a selected control card 20.

The magnet coil 74 of the electromagnet 67 is contained in an energizing circuit which includes a control switch 78 of the so-called "microswitch" type. The control switch 78 is located adjacent the guideway 21, preferably at the inner end thereof, by being secured to the support cover 12 by means of the screws 79. The control switch 78 has an actuating stem 80 projecting therefrom and engageable by a rockable lever 81 loosely mounted on a fulcrum screw 82. The lever 81 carries a trigger pin 83 which is movable in a guide sleeve 84 with the free end 83^a of the pin extending into the guideway 21 in a position to be engaged by the inner end of the control card 20 when the latter has been fully inserted into the guideway.

The final portion of the inward movement of the control card 20 causes the trigger pin 83 to be engaged and actuated by the inner end of the card to thereby close the control switch 78 and energize the electromagnet 67. The energization of the electromagnet 67 causes movement of the armature 72 to thereby swing the latch lever 69 in a direction to disengage the same from the groove 68. The disengagement of the latch lever 69 from the groove 68 releases the plunger 58 for upward movement of the head 55 by the spring 65. This upward movement of the head 55 causes rocking of the rockshaft 50 for rotating the cam 48 in a direction to release the thrust plate 46 for relatively quick downward movement of this plate and the carriage 22 by the springs 47.

The pattern of the imperforate areas 42 of the control card 20 is usually such that the control card is not reversible, but must be inserted into the guideway in one position only to cooperate with the trigger pin 83 for actuating the switch 78. To insure such insertion of the control card into the guideway 21 in such one position only, the inner end of the control card is provided with a corner notch 85. If the control card is inserted in the guideway in an inverted position, the notch 85 will register with the trigger pin 83 and no actuation of this trigger pin will be produced. When the control card is inserted into the guideway in its proper position, however, the notch 85 will be out of register with the trigger pin and ineffective, as shown in Fig. 1, while the unnotched or full other end corner of the control card will engage and actuate the trigger pin 83 for closing the contacts of the control switch 78.

It may be desirable at times during the use of the

6

selector switch device 10 to close certain of the individual switches 17 without actuating the carriage 22, or to close certain of the individual switches 17 in addition to those switches already actuated by the imperforate areas of the control card 20. This can be readily done by manually applying a downward movement to the stems 18 of the desired individual switches 17, or to the stems of the additional individual switches 17 desired to be closed. Since the upper ends of the stems 18 of all of the switches 17 are readily accessible regardless of whether the carriage 22 is in its upper or lower position, such a manual actuating force can be applied to the stems of the desired switches by engaging a suitable pushing tool against the upper ends thereof.

From the accompanying drawings and the foregoing detailed description, it will now be readily understood that this invention provides a multiple-circuit selector switch device of a very simple and durable construction and which can be applied to various uses including that of selecting and completing the various testing circuits of a tube-tester. It will also be seen that this multiple-circuit selector switch device includes a removable control card for selecting and actuating desired individual switches of a switch bank. It will be seen further, that the actuating means includes a carrier for the control card and an energizable electromagnetic device controlled by a control switch, and that such control switch is preferably located adjacent a guideway in the carrier so as to be actuated in response to movement of the control card in such guideway. Additionally, it will be seen that this selector switch device utilizes a spring pressure responsive means for the closing movement of the individual switches, such that breakage will be avoided in the event that proper closing of one of the switches selected to be actuated is prevented.

Although the multiple-circuit selector switch device of this invention has been illustrated and described herein to a somewhat detailed extent, it will be understood, of course, that the invention is not to be regarded as being limited correspondingly in scope, but includes all changes and modifications coming within the terms of the claims hereof.

Having thus described my invention, I claim:

1. In a switch mechanism, a bank of switches having movable projecting actuating stems for the respective switches, means for selecting certain of said switches for actuation including a control card having perforate and imperforate areas of which the latter areas are engageable with the stems of said certain switches, spring pressure responsive actuating means operable to cause said card to engage and actuate the stems of said certain switches, said actuating means comprising a movable card carrier having a guideway for removably receiving said card, holding means for preventing operation of said actuating means, means for releasing said holding means including an electromagnet having an energizing circuit, and switch means controlling said circuit and responsive to movement of said card in said guideway.

2. In a selector switch mechanism, a support structure, a carriage movable relative to said support structure and having a guideway therein, a control card in said guideway and having spaced openings and spaced imperforate areas, a bank of stationary switch contacts on said support structure, a bank of movable switch contacts for cooperation with the stationary contacts and including projecting contact actuating stems extending in a direction to intersect the plane of said guideway with certain of the stems aligned with said openings and other stems aligned with said imperforate areas, carriage actuating motor means including an electrically energizable means and being operable to cause said imperforate areas to engage and actuate said other stems, circuit means for said energizable means, and control switch means in said circuit means and actuatable in response to movement of said card in said guideway.

3. In a selector switch mechanism, a support struc-

7

ture, a carriage movable relative to said support structure and having a guideway therein, a control card in said guideway and having spaced openings and spaced imperforate areas, a bank of stationary switch contacts on said support structure, a bank of movable switch contacts for cooperation with the stationary contacts and including projecting contact actuating stems extending in a direction to intersect the plane of said guideway with certain of the stems aligned with said openings and other stems aligned with said imperforate areas, spring means effective on said carriage for moving said carriage and card in a direction to cause said imperforate areas to impart switch-closing movement to said other stems, holding means for preventing actuation of the carriage by said spring means, and means for releasing said holding means.

4. In a selector switch mechanism, a support structure, a carriage movable relative to said support structure and having a guideway therein, a control card in said guideway and having spaced openings and spaced imperforate areas, a bank of stationary switch contacts on said support structure, a bank of movable switch contacts for cooperation with the stationary contacts and including projecting contact actuating stems extending in a direction to intersect the plane of said guideway with certain of the stems aligned with said openings and other stems aligned with said imperforate areas, spring means effective for moving said carriage in one direction relative to said structure, cam means for moving said carriage in the opposite direction relative to said structure and for preventing operation of said spring means and operable to permit operation of said spring means, means for controlling the operation of said cam means including an electrically energizable means having an energizing circuit, and switch means controlling said circuit and responsive to movement of said card in said guideway.

5. In a selector switch mechanism, a support structure, a carriage movable relative to said support structure and having a guideway therein, a control card in said guideway and having spaced openings and spaced imperforate areas, a bank of stationary switch contacts on said support structure, a bank of movable switch contacts for cooperation with the stationary contacts and including projecting contact actuating stems extending in a direction to intersect the plane of said guideway with certain of the stems aligned with said openings and other stems aligned with said imperforate areas, a first spring means effective for moving said carriage relative to said structure and in a direction to cause actuation of said other stems by said imperforate areas, a cam having a lift stroke effective for moving said carriage in the opposite direction in opposition to said first spring means and a release stroke for releasing said carriage for actuation by said first spring means, manually operable means connected with said cam for causing said lift stroke thereof, a second spring means adapted to be flexed by said manually operable means and being effective to cause said release stroke of said cam, releasable locking means for preventing said release stroke of said cam by said second spring means, and means for releasing said locking means.

6. In a selector switch mechanism, a support structure, a carriage movable relative to said support structure and having a guideway therein, a control card in said guideway and having spaced openings and spaced imperforate areas, a bank of stationary switch contacts on said support structure, a bank of movable switch contacts for cooperation with the stationary contacts and including projecting contact actuating stems extending in a direction to intersect the plane of said guideway with certain of the stems aligned with said openings and other stems aligned with said imperforate areas, a first spring means effective for moving said carriage relative to said structure and in a direction to cause actuation of said other stems by said imperforate areas, a cam having a lift

8

stroke effective for moving said carriage in the opposite direction in opposition to said first spring means and a release stroke for releasing said carriage for actuation by said first spring means, manually operable means connected with said cam for causing said lift stroke thereof, a second spring means adapted to be flexed by said manually operable means and being effective to cause said release stroke of said cam, releasable locking means for preventing said release stroke of said cam by said second spring means, electromagnetic means having an energizing circuit and being effective to release said locking means, and switch means controlling said circuit and responsive to movement of said card in said guideway.

7. In a switch mechanism, a bank of switches having movable projecting actuating stems individual to said switches, means for selecting certain of said switches for actuation including a control card having perforate and imperforate areas of which the latter areas are engageable with the stems of said certain switches, a carriage movable to relatively move said stems and said card into engagement with each other and to cause said card to actuate the stems of said certain switches, spring type actuating means for moving said carriage, holding means for preventing the switch-actuating movement of said carriage by said spring type actuating means, and means for releasing said holding means.

8. In a switch mechanism, a bank of switches having movable projecting actuating stems for the respective switches, means for selecting certain of said switches for actuation including a control card having perforate and imperforate areas of which the latter areas are engageable with the stems of said certain switches, a carriage movable for relatively moving said stems and said card to engage said stems and said card to cause the latter to actuate the stems of said certain switches, spring pressure responsive actuating means for moving said carriage, holding means for preventing the switch-actuating movement of said carriage and card by said actuating means, means for releasing said holding means including an electromagnet having an energizing circuit, and switch means for controlling said circuit.

9. In a switch mechanism, a bank of switches having movable projecting actuating stems for the respective switches, said stems being movable in one direction to produce a closing actuation of said switches and in the opposite direction to produce an opening actuation of said switches, means for selecting certain of said switches for closing actuation including a control card having perforate and imperforate areas of which the latter areas are engageable with the stems of said certain switches, motor-operated actuating means including an electrically energizable means and being operable to cause said card to engage and cause closing actuation of the stems of said certain switches, said actuating means also comprising a card holder having a guideway for removably receiving said card therein, said holder and stems having cooperably engageable portions for causing opening actuation of the stems of previously closed switches by said holder, circuit means for energizing said energizable means, and control switch means in said circuit means and actuatable in response to movement of said card in said guideway.

10. In a selector switch mechanism, a movable carriage having a group of laterally spaced recesses therein and a group of laterally spaced openings of relatively smaller transverse dimension communicating with the respective recesses at one end of the latter, said carriage also having a guideway therein extending transversely of said recesses at the other end of the latter, a bank of switches having movable actuating stems projecting therefrom and extending into said recesses through said openings, a control card in said guideway and having spaced areas engageable with certain of said stems, said card being movable with said carriage, means for actuating said carriage to engage the spaced card areas with said

certain stems for imparting switch actuating movement to the latter, and shoulder means on said stems and disposed in said recesses.

11. Selector switch mechanism as defined in claim 10 in which the engagement of said card areas with said certain stems imparts switch actuating movement to the latter in one direction, said shoulder means being shiftable in said recesses and being engageable by said carriage substantially at said one end of said recesses for causing switch actuating movement in the opposite direction to be imparted to said stems by said carriage.

12. Selector switch mechanism as defined in claim 10 in which said stems have end portions extending beyond said shoulder means and said carriage has other openings therein communicating with said recesses at said other end of the latter and adapted to receive said end portions of the stems, said control card having spaced openings therein adapted to register substantially with certain of said other openings.

13. In a selector switch mechanism, a support having a bank of stationary switch contacts thereon, a carriage having switch closing and switch opening movements toward and away from said stationary contacts and having an open switch position spaced from said support, said carriage having a group of spaced-apart recesses therein and spaced openings of relatively smaller transverse dimension communicating with the respective recesses at the ends of the latter facing said stationary contacts, a bank of contact plungers extending toward said stationary contacts from said openings, a control card disposed in said carriage for switch closing movement with the latter, and collars on said plungers and shiftably confined in said recesses, said plungers being selectively actuatable into engagement with said stationary contacts in response to the switch closing movement of said carriage and card, said collars being engageable with said carriage at the first mentioned ends of said recesses for maintaining all of said plungers disengaged from said stationary contacts while said carriage is in its open switch position.

14. In a selector switch mechanism, a support having a bank of stationary switch contacts thereon, a carriage having switch closing and switch opening movements toward and away from said stationary contacts and having an open switch position spaced from said support, said carriage having a group of spaced-apart recesses therein and spaced openings of relatively smaller transverse dimension communicating with the respective recesses at the ends of the latter facing said stationary contacts, said carriage also having a guideway therein extending across said recesses adjacent the other end of the latter, a control card removably engaged in said guideway and having imperforate areas overlying certain of said recesses and openings overlying others of said recesses, a bank of contact plungers extending through said spaced openings and being individually engageable with the respective stationary contacts, certain of said plungers being engageable by said areas for causing actuation of said certain plungers into engagement with certain of said stationary contacts in response to switch closing movement of said carriage, and collars on said plungers and confined in said recesses for causing opening actuation of said certain plungers in response to the switch opening movement of said carriage.

15. Selector switch mechanism as defined in claim 14 in which said plungers have outer end portions extending beyond said collars and movable into the openings of said card to prevent closing actuation of others of said plungers by said carriage.

References Cited in the file of this patent

UNITED STATES PATENTS

2,074,002	Tauschek -----	Mar. 16, 1937
2,198,503	Morrison -----	Apr. 23, 1940
2,744,973	Murchison -----	May 8, 1956
2,794,869	Noregaard -----	June 4, 1957