

M. BENJAMIN.  
WATCH.

No. 458,745.

Patented Sept. 1, 1891.

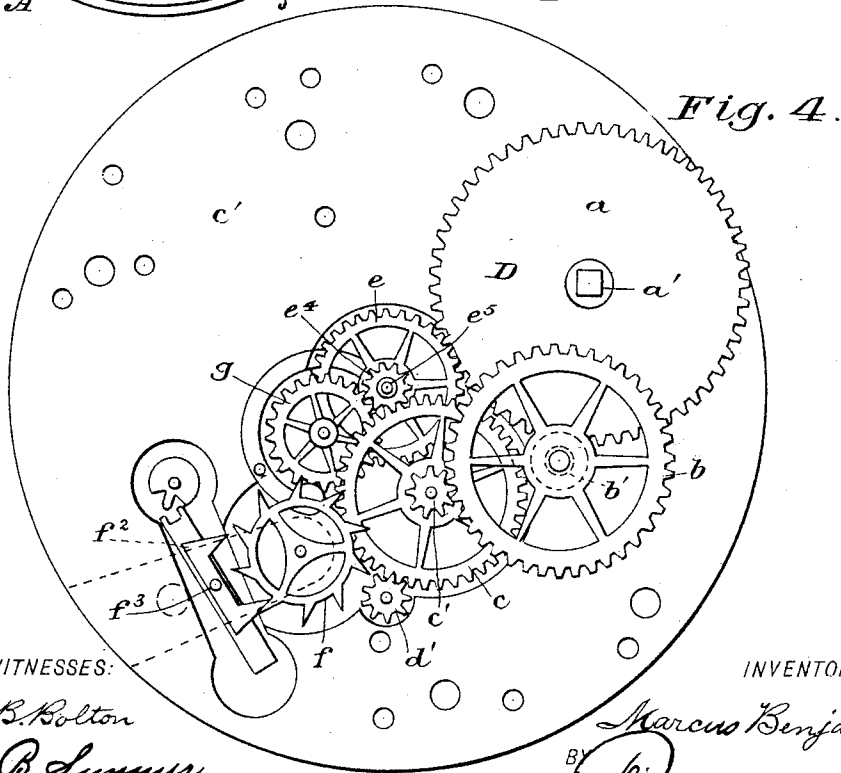
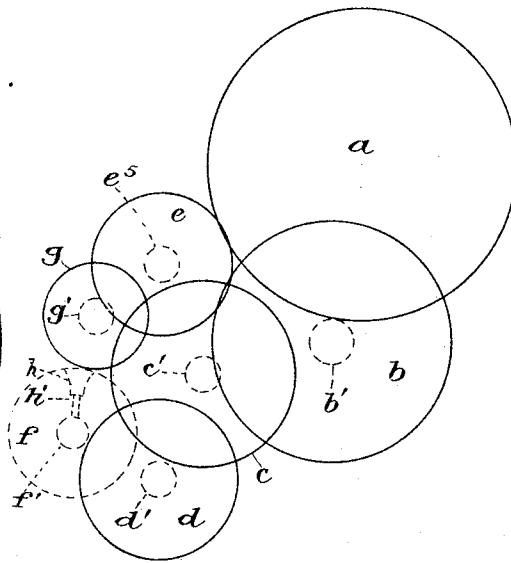
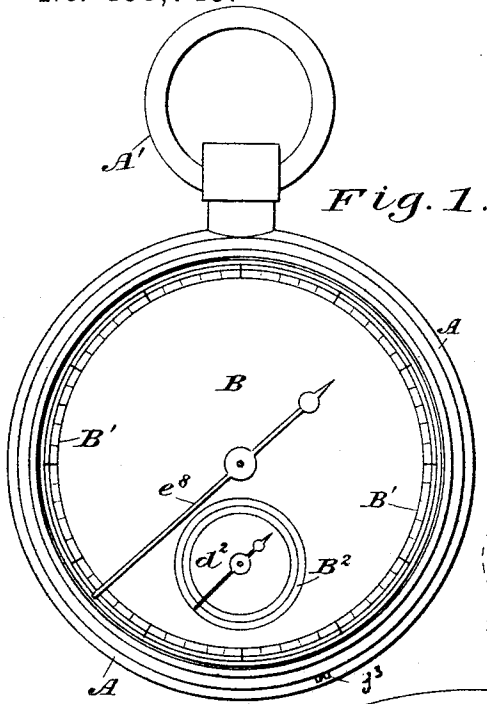

WITNESSES:

*E. B. Bolton*  
*A. B. Sumner,*

INVENTOR

*Marcus Benjamin*  
BY *Richard*  
ATTORNEYS

M. BENJAMIN.  
WATCH.

No. 458,745.

Patented Sept. 1, 1891.

Fig. 2.

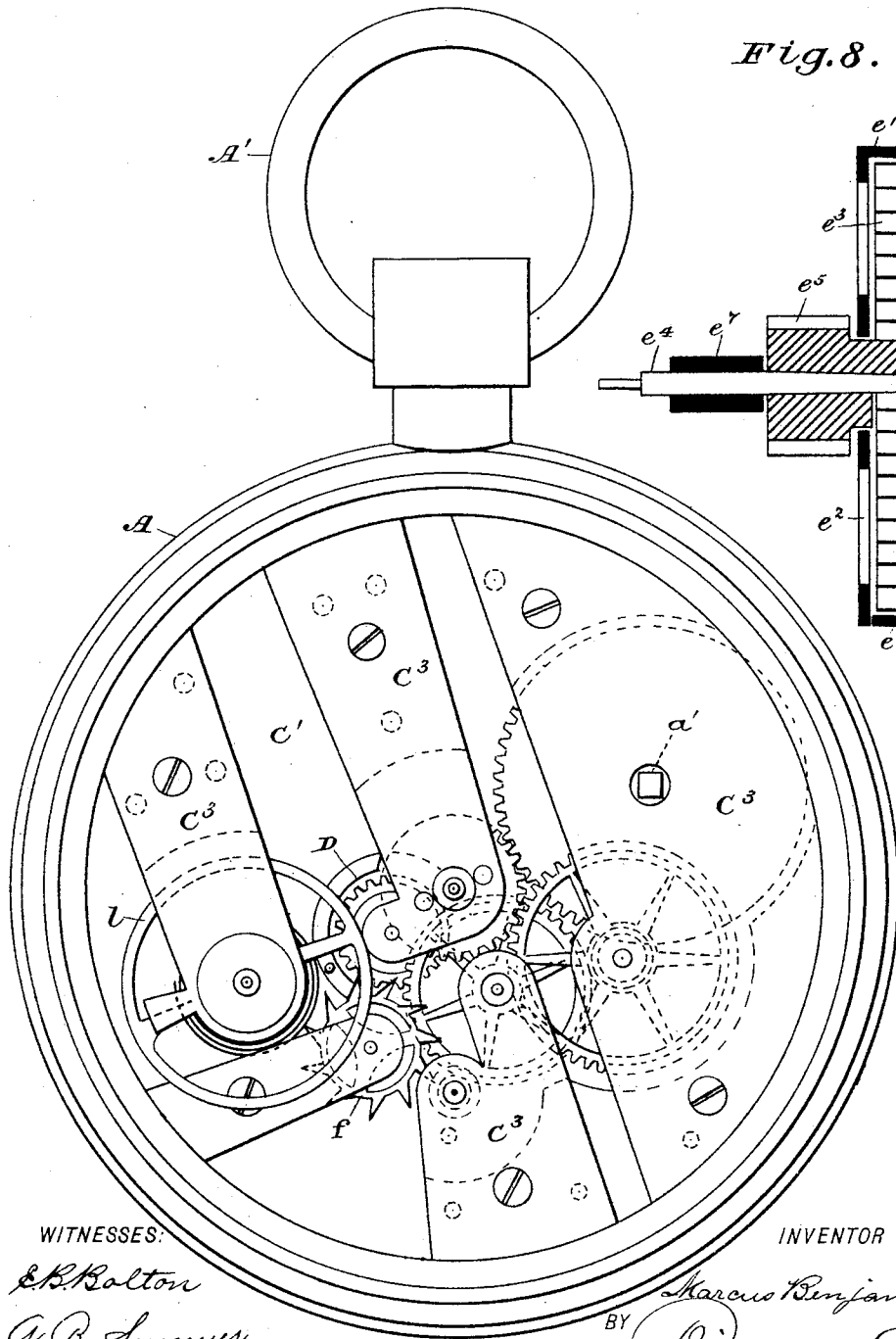
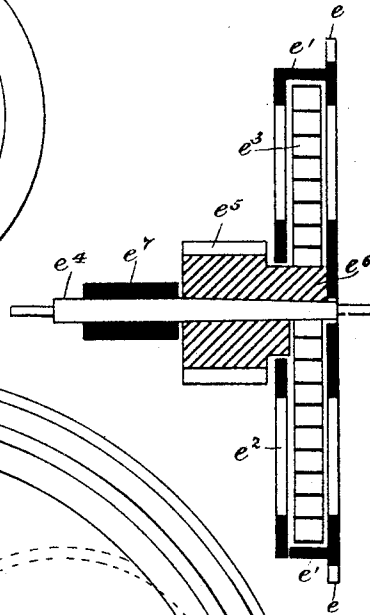

Fig. 8.



WITNESSES:

*E. B. Bolton*

*A. B. Sumner.*

INVENTOR

*Marcus Benjamin*

BY

*Richardson*

ATTORNEYS



# UNITED STATES PATENT OFFICE.

MARCUS BENJAMIN, OF SYDNEY, NEW SOUTH WALES, ASSIGNOR OF ONE-HALF TO JOHN HARDY, OF SAME PLACE.

## WATCH.

SPECIFICATION forming part of Letters Patent No. 458,745, dated September 1, 1891.

Application filed July 23, 1890. Serial No. 359,703. (No model.)

To all whom it may concern:

Be it known that I, MARCUS BENJAMIN watch-maker, a subject of the Queen of Great Britain, residing at Sydney, in the British Colony of New South Wales, have invented new and useful Improvements in the Movements of Watches and other Time-Pieces, of which the following is a specification.

This invention has been specially devised in order to produce a watch or time-piece having but one "movement" or train of wheels, but having an independent center seconds-hand showing full seconds in one beat around the face or dial, as well as an ordinary seconds-hand on a seconds-dial. By this invention dispensing, as it does, with one movement or train of wheels a "center seconds independent" watch may be manufactured with a reduction of, say, seventy-five per cent. in working parts and connections, and so considerably reduce the size and cost of the finished article. These improvements in the movements of watches and other time-pieces consist, first, in the combination and arrangement, with a third wheel driven by barrel and center wheels, of a center seconds independent (or an additional or second fourth) wheel driven by a pinion in gear with said third wheel having elastic and frictional connection with said pinion and having means for intermittently suspending its motion, and, secondly, they consist in the combination and arrangement, with such a center seconds independent wheel, of governing or detaining gear in connection with the pinion of the escapement, so as to regulate the motion and beats of said center seconds independent wheel and hand; but in order that this invention may be clearly understood reference will now be made to the drawings herewith, in which is illustrated a watch made according to this invention, but from which watch ordinary and well-known movements have been removed.

Figures 1 and 2 are front and back views, respectively, of a watch fitted with my improvements. Fig. 3 is front view with the dial-plate removed, and Fig. 4 is back view showing the movement. Fig. 5 is a diagram, and Figs. 6 and 7 are enlarged details of same, while Fig. 8 is a further enlarged section of

the center seconds independent wheel and pinion.

A is the case.

B is the face or dial-plate.

C is the frame or plate.

D is the movement.

A' is the suspension-ring.

B' is the center seconds-dial, and B<sup>2</sup> the small seconds-dial.

c marks the dial side, and C' the back side.

C<sup>2</sup> is the superposed dial side bars or cocks, and C<sup>3</sup> the superposed back side bars or cocks.

a is the barrel.

b is the second wheel; c, the third wheel; d, the fourth or seconds wheel; e, the center seconds-wheel; f, the escape-wheel, and g the intermediate wheel.

h is the pinion.

i is the balance.

j is the stop-bar.

a' is the barrel-arbor with mainspring, &c., of ordinary construction.

b' is a pinion, c' is a pinion, and d' is a pinion.

d<sup>2</sup> is the small seconds-hand.

e' is the ring-flange; e<sup>2</sup>, the flange or cover; e<sup>3</sup>, the circular spring; e<sup>4</sup>, the arbor or axis; e<sup>5</sup>, the pinion; e<sup>6</sup>, the boss; e<sup>7</sup>, the tightening-sleeve, and e<sup>8</sup> the center seconds-hand.

f' is the pinion, f<sup>2</sup> the pallet, and f<sup>3</sup> the pallet-staff.

g' is the pinion.

h' is the engagement-pin.

j' is the curved point, j<sup>2</sup> the fulcrum, and j<sup>3</sup> the outside head.

The watch being wound up as ordinarily by a key or by a keyless winding-gear, the barrel a revolves and gives motion, as well understood, to the pinion d', which moves the small seconds-hand d<sup>2</sup> round the dial B<sup>2</sup>. One end of spring e<sup>3</sup> is fitted in boss e<sup>6</sup> by means of a slot, and the other end has firm frictional contact against the inner periphery of ring or blank e' of wheel e. The barrel a also gives motion, as well understood, to pinion e<sup>5</sup>, and as this revolves the friction of the spring e<sup>3</sup> causes wheel e, when it is freed from the other gearing, to revolve and move the center seconds-hand e<sup>8</sup>. The wheel e has its motion governed from the escape-wheel f by the pin-

55

60

65

70

75

80

85

90

95

100

ion  $g'$ , intermediate wheel  $g$ , pinion  $h$ , and pin or lever  $h'$ , as follows: The fourth or seconds wheel  $d$  revolves the escape-wheel  $f$  by turning pinion  $f'$ , and as a leaf or tooth of said pinion is moved it allows pin or lever  $h'$  to pass and gives freedom to wheel  $e$ , which is then revolved, as before described, until pin or lever  $h'$  is again detained momentarily or for an infinitesimally short period until allowed to pass by a further movement of the pinion  $f'$ , when the next leaf or tooth again releases said pin or lever  $h'$ . The momentary stops given to the motion of the center seconds-wheel  $e$  by the detention of said pin or lever  $h'$  wind the spring  $e^3$  as pinion  $e^5$  continues to revolve, and when the said pin  $h'$  is released the motion of pinion  $e^5$  and the expansion of the spring  $e^3$  revolves the wheel  $e$  with a regular rotary motion and a regular momentary stoppage, which motion is imparted to the center seconds-hand  $e^8$  by way of beats, during which the said hand moves the distance of a full seconds-space upon the dial  $B'$ . When the independent seconds are not required, the stop-bar  $j$  is pushed aside by the finger-nail and, moving on fulcrum  $j^2$ , causes the point  $j'$  to move within the passage of the pin  $h'$  and become a stop to the revolution of said pin  $h'$ . The intermediate gear  $g$  and  $h$  will thus be held fast and will hold the wheel  $e$  stationary, in which case the spring  $e^3$  will wind up and revolve with the

pinion  $e^5$ ; the center seconds-hand will remain at rest, and the other movements of the watch will not be in any way checked or affected. 35

It is to be understood that I do not confine myself to the precise manner and means herein described and shown of carrying my invention into effect, so long as the nature of the same be retained, nor do I confine myself to any kind or class of time-piece to which the same may be applied. 40

Having now particularly described and explained the nature of my said invention and in what manner the same is to be performed, I declare that what I claim is— 45

In the movements of watches and other time-pieces, the combination and arrangement, with a third wheel, of an additional or second "fourth wheel" or center second independent wheel, such as  $e$ , having a ring-flange, such as  $e'$ , and an arbor or axis, such as  $e^4$ , a pinion, such as  $e^5$ , a connecting or second spring, such as  $e^3$ , a center seconds-hand, such as  $e^8$ , and means for intermittently suspending the motion of the said arbor or axis, substantially as herein described and explained, and as illustrated in the drawings. 50 55

MARCUS BENJAMIN.

Witnesses:

FRED WALSH,

*F. M. Inst. P. A.*

FRED J. BEARDMORE.